

AD-4404

INSTRUCTION MANUAL

Check Weighing Indicator

AND

A&D Company, Ltd.



This is a hazard alert mark.



This mark informs you about the operation of the product.

Note This manual is subject to change without notice at any time to improve the product. No part of this manual may be photocopied, reproduced, or translated into another language without the prior written consent of the A&D Company.

Product specifications are subject to change without any obligation on the part of the manufacture.

□ Modbus is a registered trademark of the Schneider Electric Corporation.

Copyright©2019 A&D Company, Limited

Contents

1.	Compliance	5
1.1.1.	Compliance with FCC rules	5
1.1.2.	Compliance with European Directives	5
2.	Outline and Features	6
2.1.	Precautions	7
2.2.	Front Panel	8
2.2.1.	Keys	9
2.2.2.	Symbols	10
2.3.	Rear Panel	11
3.	Installation	12
3.1.	Installing Options	12
3.2.	Mounting the Indicator	13
3.3.	Connecting the Loadcell Cable	14
3.3.1.	Verifying Loadcell Output and Input Sensitivity	15
3.4.	Wiring the Power Cord	16
4.	Basic Operation	17
4.1.	Key Operation Examples	17
4.1.1.	Standby Mode	17
4.1.2.	Cursor Operation	17
4.1.3.	Inputting Characters	17
4.1.4.	Calling a Code	18
4.1.5.	Entering a Correction Mode	18
4.1.6.	Entering The Menu	18
4.2.	Status Chart	19
4.2.1.	Mode Map and Menu	19
4.2.2.	Status of Weighing Mode	20
5.	Calibration	21
5.1.	Actual Load Calibration (using a Mass)	22
5.2.	Digital Span (Calibration without a Mass)	23
5.3.	Gravity Acceleration Correction	24
5.3.1.	Gravity Acceleration Reference	24
5.4.	Calibration Error	25
6.	Check Weighing Sequence	27
6.1.	Automatic Mode (weighing in motion)	27
6.2.	Conveyor Stop Mode	29
6.3.	Foreign Matter Detection	31
6.4.	OK Mode	33
6.5.	Manual Mode	35
6.6.	Simple Mode	37
6.7.	Status and Check Weighing Sequence	39
7.	Code	43
7.1.	Use of the Code	44
7.1.1.	Recalling a Code	44

7.1.2.	Editing a Code in the Sub-display	44
7.2.	The Menu of Code Edit	45
7.2.1.	Edit	45
7.2.2.	Search	45
7.2.3.	Delete	46
7.2.4.	Copy	46
7.2.5.	Preset Tare	47
7.3.	Recalling a Code	48
8.	Other Functions	50
8.1.	Zero Tracking Function	50
8.1.1.	Static Zero Tracking Function	50
8.1.2.	Dynamic Zero Tracking Function	51
8.2.	Judgement and Selector Action	52
8.3.	Loss-in-weight	53
8.4.	Motion Compensation	53
8.5.	Detection Method	54
8.5.1.	Detecting Front with Position Sensor	54
8.5.2.	Detecting End with Position Sensor	54
8.5.3.	Detecting Gross Value above Zero Band	55
8.5.4.	Detecting Gross Value within Zero Band	55
8.6.	Check to Forward the Article	55
8.7.	Duplication of the Articles	56
8.8.	Crush of the Articles	56
8.9.	BUSY Output	57
8.10.	Stop Input during BUSY	57
8.11.	Output for Foreign Matter Detection	58
8.12.	Evaluation Output	58
8.12.1.	Comparison Output	58
8.12.2.	Output to Selectors	59
8.13.	Buzzer Output	60
8.14.	Total Function	60
8.15.	Safety Check Function	61
8.16.	Zero Operation	62
8.17.	Tare Operation	63
8.17.1.	Tare Clear Operation	63
8.18.	Preset Tare	64
8.19.	Customizing F1 and F2 key	64
8.20.	Customizing Sub Display	65
8.21.	Graph Display	68
8.22.	Canceling Last Judgement	69
8.23.	Clearing the Total	69
8.24.	Error Message and Alarm	70
8.25.	Graphic Status Indicator	72
8.26.	Memory Backup	73
9.	Interface	74
9.1.	Control I/O Function	74
9.1.1.	Interface Circuit	74
9.1.2.	Timing Chart	75
9.2.	Built-in RS-485 Interface	76
9.2.1.	Settings of Parameters for RS-485	76
9.2.2.	Connection	77

9.2.3.	Timing Chart	78
9.2.4.	Communication Modes	78
9.2.5.	General Data Format	79
9.2.6.	A&D Data Format.....	80
9.2.7.	Address.....	81
9.2.8.	Command List.....	82
9.2.9.	ASCII Code for Display Characters.....	83
9.2.10.	Protocol (Communication Procedure and Format).....	84
9.3.	Modbus Interface for RS-485.....	91
9.4.	Built-in Current Loop Output	98
9.4.1.	Connection.....	98
9.4.2.	Communication Modes	98
9.4.3.	Data Format.....	99
9.4.4.	Settings of Parameters for Current Loop	99
9.4.5.	Print Format (Process Print)	99
9.4.6.	Time Stamp	102
9.5.	BCD Output of Option OP-01.....	103
9.6.	Relay Output of Option OP-02	107
9.7.	RS-422/485 Interface of Option OP-03	108
9.8.	RS-232C Interface of Option OP-04	111
9.9.	Parallel I/O of Option OP-05	112
9.10.	Analog Output of Option OP-07	114
10.	Maintenance (Monitor and Test)	115
10.1.1.	Basic Operation	115
10.2.	Monitor Mode.....	115
10.2.1.	Monitoring the Control I/O Function	115
10.2.2.	Monitoring Built-in RS-485 Interface	115
10.2.3.	Monitoring Built-in Current Loop Output.....	116
10.2.4.	Monitoring A/D Converter	116
10.2.5.	Monitoring BCD Output of OP-01	116
10.2.6.	Monitoring Relay Output of OP-02.....	116
10.2.7.	Monitoring RS-422/485 Interface of OP-03.....	117
10.2.8.	Monitoring RS-232C Interface of OP-04	117
10.2.9.	Monitoring Parallel I/O of OP-05.....	117
10.2.10.	Monitoring Analog Output of OP-07	117
10.3.	Test Mode.....	118
10.3.1.	Testing Control I/O Function	118
10.3.2.	Testing Built-in RS-485 Interface	118
10.3.3.	Testing Built-in Current Loop Output.....	118
10.3.4.	Testing A/D Converter	119
10.3.5.	Testing BCD Output of OP-01	119
10.3.6.	Testing Relay Output of OP-02.....	119
10.3.7.	Testing RS-422/485 Interface of OP-03.....	119
10.3.8.	Testing RS-232C Interface of OP-04	120
10.3.9.	Testing Parallel I/O of OP-05.....	120
10.3.10.	Testing Analog Output of OP-07	120
10.4.	Initializing Parameters	121
10.5.	Remote Operation.....	123
11.	Function List.....	124
11.1.1.	Operation Keys	124
11.1.2.	Outline of the Function List	125

11.2. Referring Parameters.....	126
11.3. Parameter List	127
12. Specifications.....	155
12.1. Dimensions	158
12.2. Accessories	158
13. Index.....	159



1. Compliance

1.1.1. Compliance with FCC rules

- Please note that this equipment generates, uses and can radiate radio frequency energy. This equipment has been tested and has been found to comply with the limits of a Class A computing device pursuant to Subpart J of Part 15 of FCC rules. These rules are designed to provide reasonable protection against interference when this equipment is operated in a commercial environment. If this unit is operated in a residential area it may cause some interference and under these circumstances the user would be required to take, at his own expense, whatever measures are necessary to eliminate the interference.

(FCC = Federal Communications Commission in the U.S.A.)

1.1.2. Compliance with European Directives

CE This appliance complies with the statutory EMC (Electromagnetic Compatibility) directive 89/336/EEC and the Low Voltage Directive 73/23/EEC for safety of electrical equipment designed for certain voltages.

Note: The displayed value may be adversely affected under extreme electromagnetic influences.



2. Outline and Features

- The AD-4404 indicator is designed for checking and/or selecting the weight of products carried on conveyors. The indicator has five weighing modes and a selection function to classify 5 levels of weight. As a check weighing example, there is a check weighing application, using a foreign matter detector.

- Large display
The indicator has a blue vacuum fluorescent display (VFD).
The character height of the main display is 18 mm.
Current weighing data, names, setpoints (comparison references) and total data are displayed at the same time.

- Water-resistant panel
The classification code of the front panel is equivalent to IP-65 of IEC 529 using the accessory rubber packing. The "IP-65" code is explained as follows:
IP: International Protection.
6: Against ingress of solid foreign objects.
Dust-tight. No ingress of dust.
5: Against ingress of water with harmful effects.
Protected against water jets (no powerful jets). Water projected in jets against the enclosure from any direction shall have no harmful effects.

- Operation guidance
Messages that assist current operation are displayed on the front panel and major operators should be able to operate the indicator without referring to the instruction manual.

- Full weighing sequences
The following five modes are installed in the AD-4404;
Automatic mode, conveyor stop mode, OK mode, manual mode and simple mode.
The five levels to select or check weight can be used for the check weighing.
AD-4404 can be linked to a foreign matter detector.
External buzzer has different sounds adapted to the result.

- RS-485 interface
32 indicators can be connected to a programmable controller or a personal computer.
The protocols are according to public formats.

- Optional accessories
Interface options: AC 250 V direct drive relay, serial interface,
parallel interface, analog output, etc.
There are three expansion slots for options.

- Check mode during operation
The monitor mode can confirm system status during operation.
The test mode can test the Input / Output interface.
Even if there is no monitor instrument, the interface can be confirmed.



2.1. Precautions

Before use, confirm the following articles for safe operation.

- Grounding the indicator
Ground the indicator. The earth terminal ⊕ is on the rear panel.
Separate this earth ground line from others, like ground line of a motor, inverter or a power source. Unless the indicator is grounded, it may result in receiving an electric shock, cause operation error or catch fire.
- Use an adequate power cord
Confirm the AC voltage, current of the power cord and the receptacle type. If the voltage range of the cord is lower than the power line voltage, it may cause leakage or catching fire. Use compression terminals to connect the power cord to the rear panel terminals.
- Fuse
The fuse is installed to help prevent the indicator from catching fire.
The indicator is equipped with many safety circuits. Therefore, the fuse is not damaged in normal operation. If the fuse is damaged, do not replace it, contact your local A&D dealer. This trouble may have been caused by strong electric discharge.
- Splashing water
The indicator is not water-resistant. When the indicator is mounted to a panel with the accessory rubber seal, the front panel is equivalent to IP-65.
- Flammable gas
Do not install the indicator where flammable gas is present.
- Heat radiation of the indicator
Space out instruments to radiate heat sufficiently.
Use a cooling fan to keep the operating temperature of the indicator within specifications.
- Removing the cover
Disconnect the indicator from the power source before removing the cover to avoid receiving an electric shock.
Do not touch the internal circuit within 10 seconds after turning off the indicator to avoid receiving an electric shock.



2.2. Front Panel

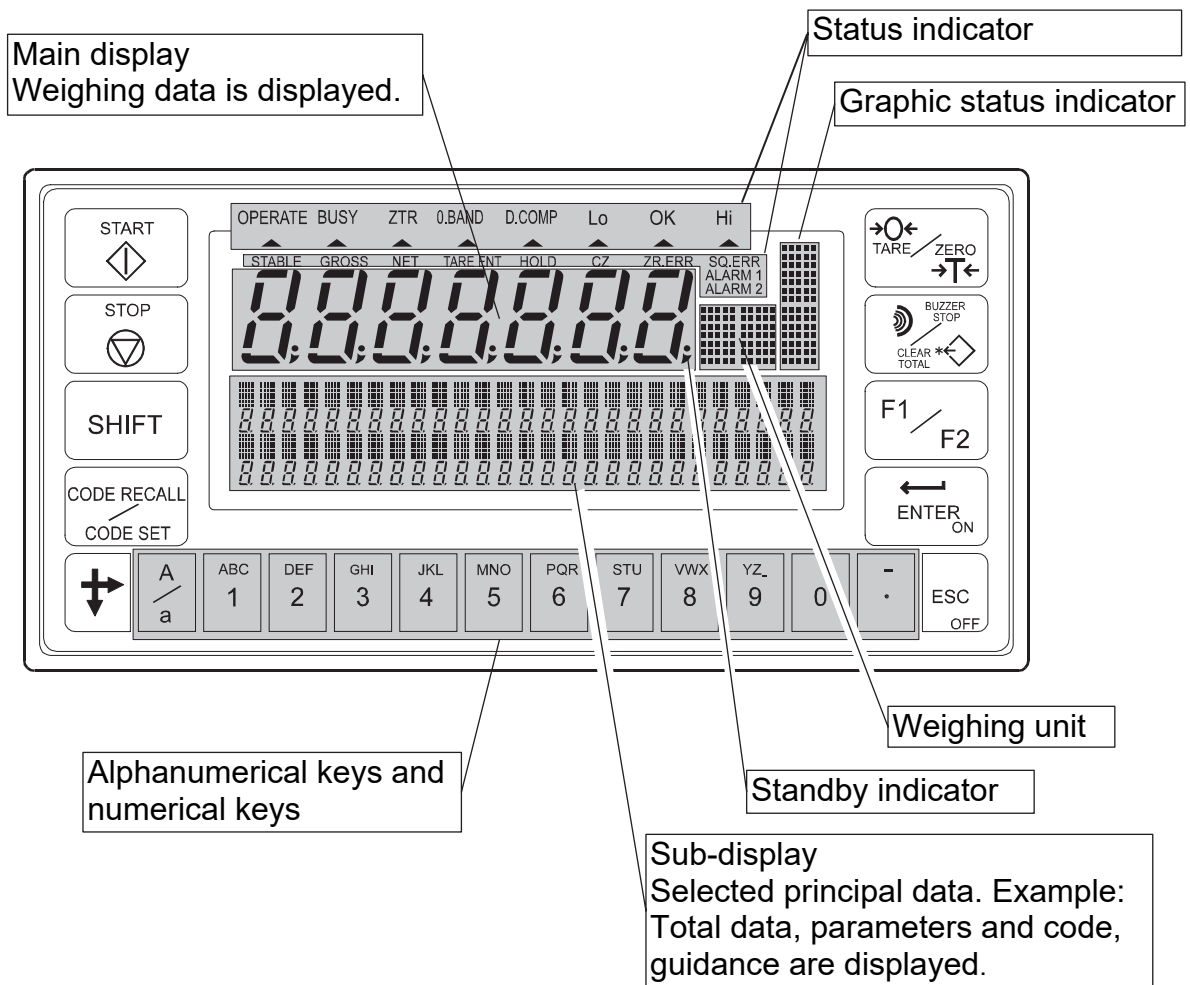

Display

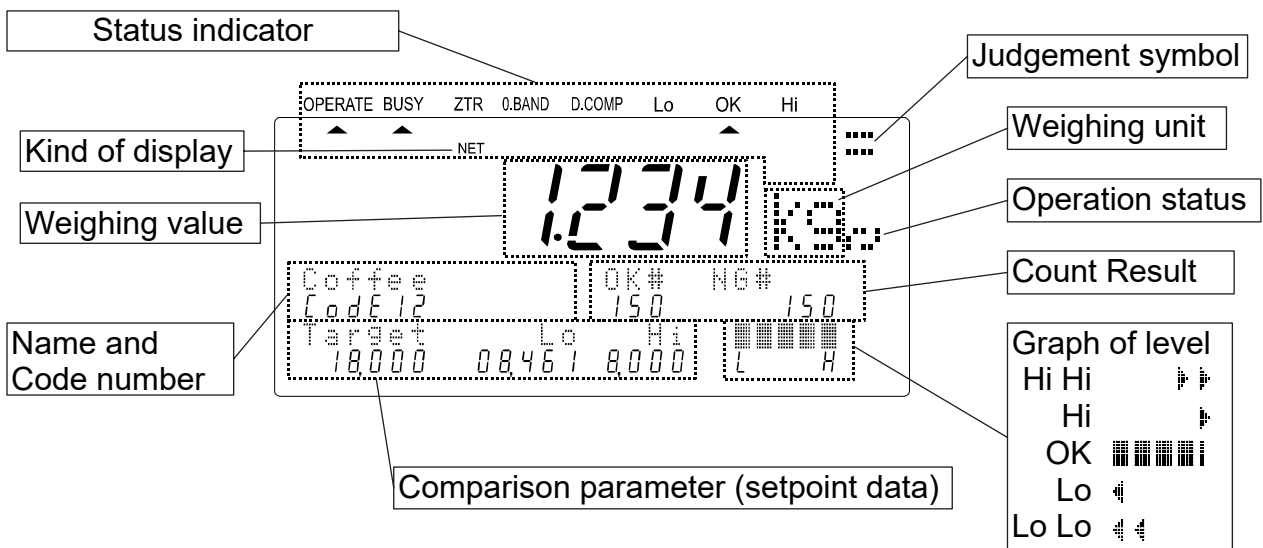

2.2.1. Keys



The **START** key of the conveyor belt.



The **STOP** key of the conveyor belt.



The key to select a function of a key.



The key to call the code.

Pressing the **CODE RECALL** key to recall the code.

Pressing and holding the **SHIFT** key, press the **CODE SET** key to select the principal codes for display in the sub-display.



The key to move the cursor or scroll the function number.

Pressing and holding the **SHIFT** key, press the  key to decrease the code number.



The key to select alphabetical keys, upper keys, lower keys or numerical keys.

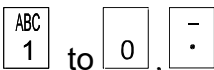

Alphanumeric keys.



The escape key.

The **ESC** key is used to undo the last key action and to return to the previous mode.

Pressing and holding the **OFF** key more than three seconds in weighing mode, turn off the display (Standby mode).



The **ENTER** key for parameter settings.

The **ON** key turns on the display while in standby mode.

Pressing and holding this key, press the  key to enter the menu.

Pressing and holding the **TARE** key, press the **ON** key after turning off, the indicator displays gross value and does not to compensate zero.



Pressing this key, the key works as the **F1** key.

Pressing and holding the **SHIFT** key, press this key, the key works as the **F2** key. Preset the function of the **F1** and **F2** key at *at hEF-2* and *at hEF-3* in the function list.



The key to shut off the buzzer.

Pressing and holding the **SHIFT** key, press the **CLEAR TOTAL** key to clear the total data of the current code.



Pressing the key, this key works as the **TARE** key. The tare key is used to display the net value that subtracts the tare weight from the gross value.

Pressing and holding the **SHIFT** key, press the **ZERO** key, this key works as the zero key. The current weighing display becomes zero and displays sign CZ.

2.2.2. Symbols

Main display	While weighing sequence mode stops, weighing data is displayed. While weighing sequence mode operates, each judged weighing value is held and is displayed.
Sub display	Code numbers, operation guidance, graph, setpoint and others are displayed selectively.
Weighing unit	The indicator that is displayed when the weighing unit is selected in the calibration mode.
Status indicator	The current weighing status is displayed.
Graphic status indicator	The current weighing situation is displayed with symbols. The classification number is displayed, when an error occurred or an alarm is indicated.
STABLE	The sign is illuminated when the current weighing display is stable.
GROSS	The sign is illuminated when the main display is the gross data.
NET	The sign is illuminated when the main display is the net data.
TARE ENT	Tare entered. The sign is illuminated when a tare value stored.
HOLD	The sign is illuminated when the main display is held.
CZ	Center of zero. The sign is illuminated when the gross value is within the center of the zero point of zero calibration.
ZR.ERR	Zero error. Error message for zeroing the gross data of the main display.
SQ.ERR	The sequence error sign. Indicates a weighing sequence error.
ALARM 1	An error sign preset to alarm 1 .
ALARM 2	An error sign preset to alarm 2 .
Operate ▲	The sign is illuminated while the weighing sequence works. The sign is turned on and off while the weighing sequence is pause.
BUSY ▲	The sign is illuminated while material is weighed and data is processed.
ZTR ▲	Zero track function. The sign is illuminated for one second when zero track function works.
0. BAND ▲	The zero band sign. When the gross data is within the range of the zero band (around the zero point), this sign is illuminated.
D.COMP ▲	Dynamic compensation function to correct weighing value. The sign is illuminated when the coefficient is not 1 in the automatic mode.

Lo
▲

The weighing data is lighter than lower limit. Data < Lower limit.

OK
▲

The weighing data is acceptable. Lower limit \leq Data \leq Higher limit

Hi
▲

The weighing data is heavier than higher limit. Higher limit < Data



2.3. Rear Panel

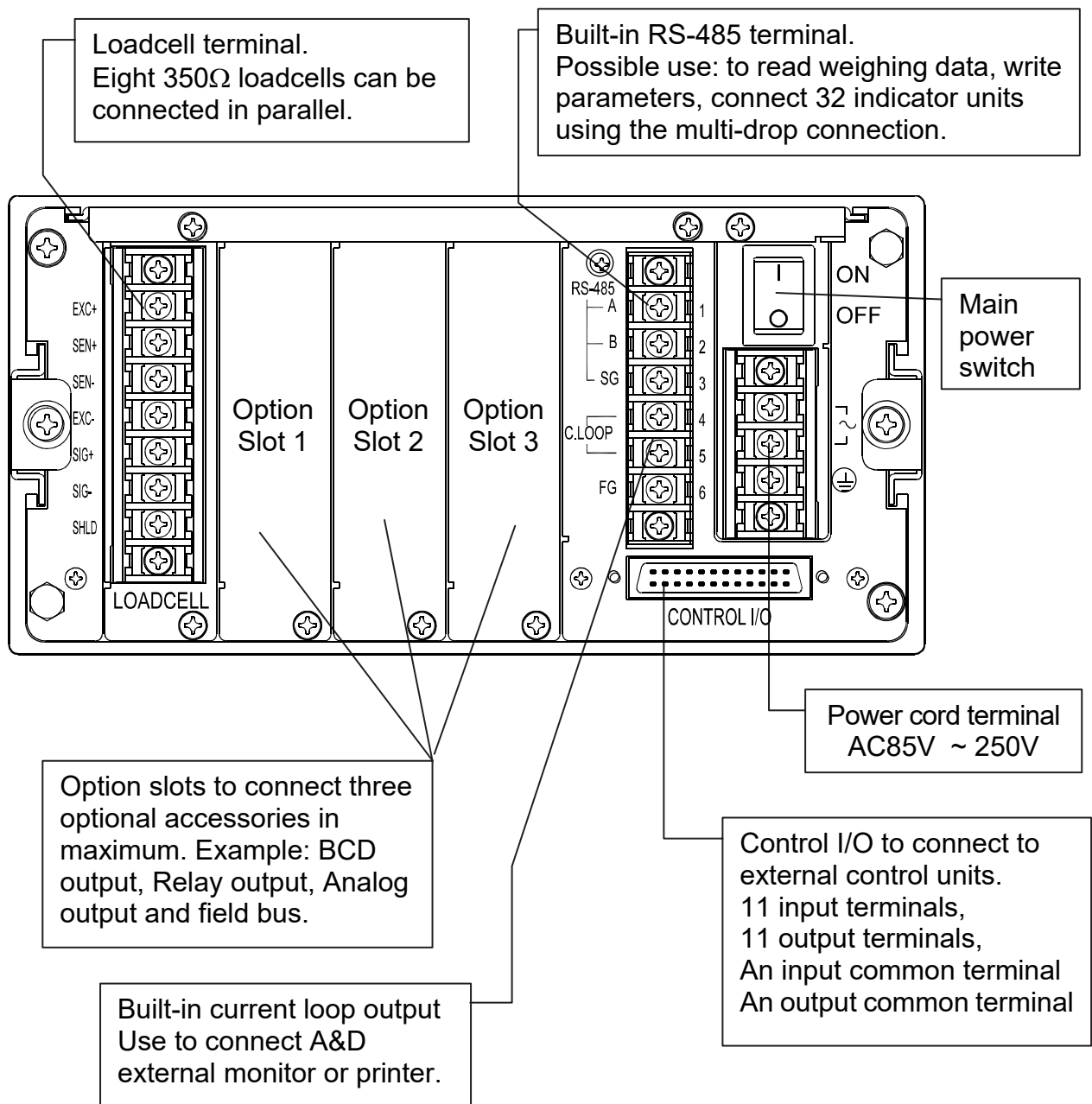



3. Installation

Installation Procedure

- ❑ Remove the power cord before installing the indicator or an option.
- ❑ Turn off peripheral devices before connecting them.
- ❑ Insert the options before installing the indicator.
- ❑ Mount the indicator to the panel.
- ❑ Connect cables and wires to the indicator.



3.1. Installing Options

Caution

- ❑ **Remove the power cord before installing an optional accessories.**
- ❑ **Do not install the same option to input data or communication option using slots. Do not assign the same function to multiple input terminals.**
- ❑ **Never touch the internal parts within ten seconds after removing the power cord because you may receive an electric shock.**
- ❑ **Do not forget to tighten the screws. If a screw is not tightened, it may cause a short circuit or an error due to noise.**

Step 1 Remove the power cord.

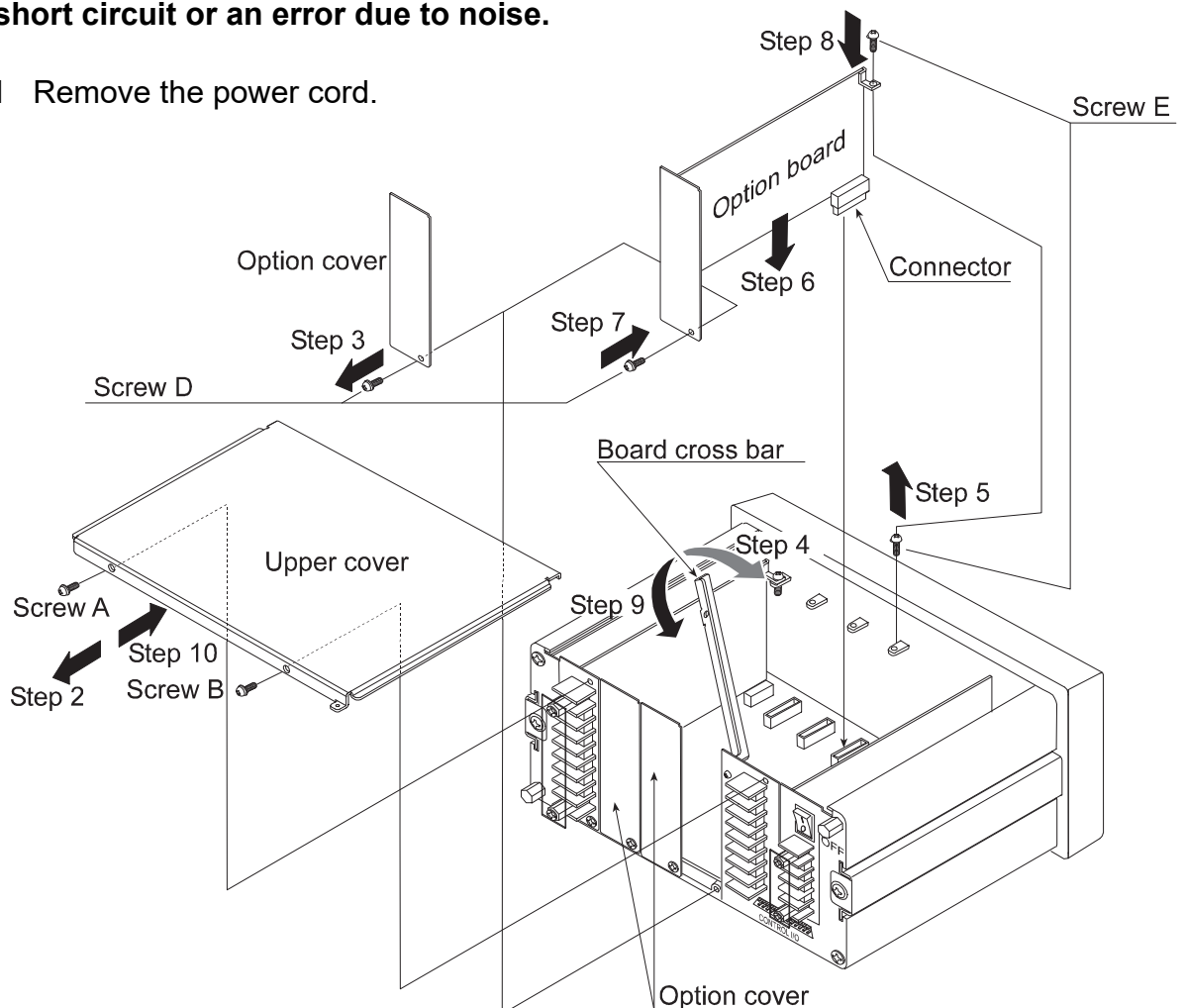

Step 11 Initialize the RAM data in accordance with section "9.4. Initializing Parameters".



3.2. Mounting the Indicator

- The indicator can be mounted on a panel using the slide rails.
- If the accessory packing rubber is used, the front panel is equivalent to IP-65 of IEC 529.

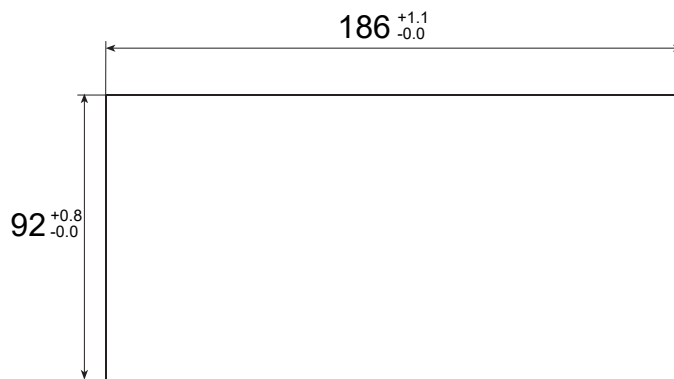
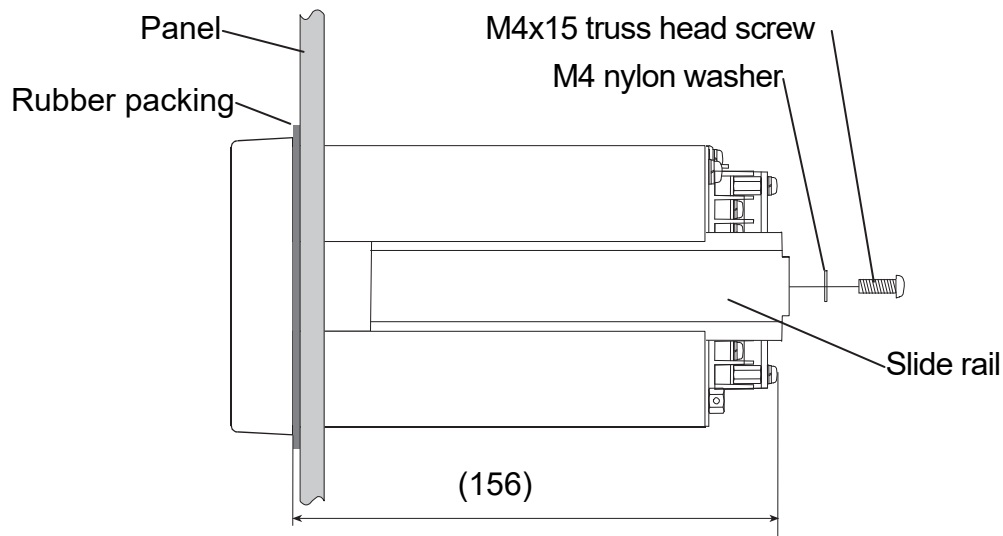

Panel Cutout Size



3.3. Connecting the Loadcell Cable

Caution

- Do not share the loadcell cable with noise-generating devices or power lines, because the loadcell signal is very sensitive.
- We recommend that you use a 6 wire shielded cable to prevent loss of weighing precision.
- If the length of loadcell cable is shorter than 5 m, you may use a 4 wire shielded cable with terminals 1 & 2 connected together (connected EXC+ and SEN+) and terminals 3 & 4 connected together (connected EXC- and SEN-).

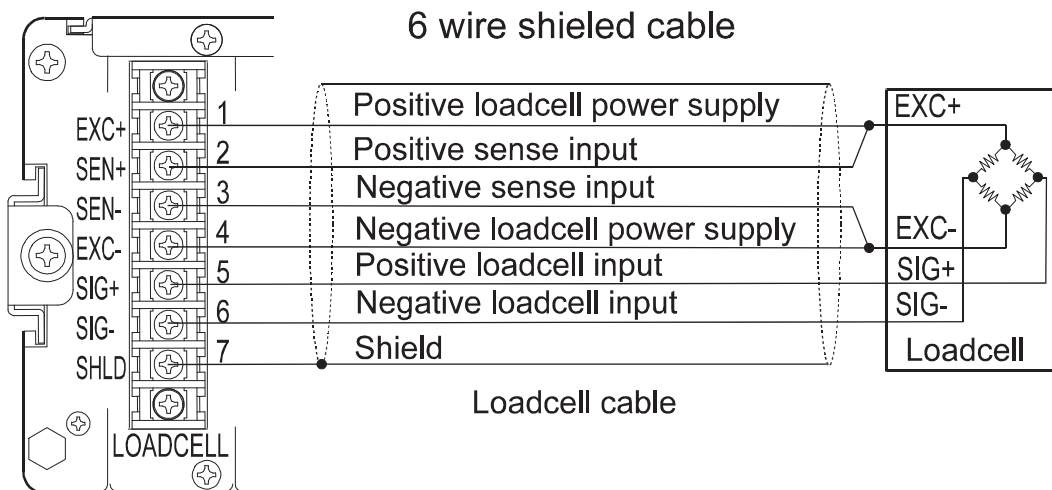

Adaptable Compression Terminal Parts

- Use the appropriate compression terminal parts to attach the cables.



Loadcell Output Adjustment for Zero Calibration (Zero Point Adjustment)

- If the message "ERR2" is displayed, the zero point of zero calibration is too large.
- If the message "ERR3" is displayed, the zero point of zero calibration is too small.
- Use a resistor of more than 50 kΩ with low (good) temperature coefficient, when adding a resistor, to adjust the loadcell output, to the indicator terminals.

In Case of Positive Offset

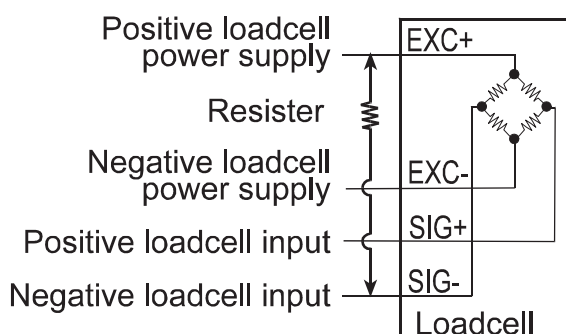

In Case of Negative Offset

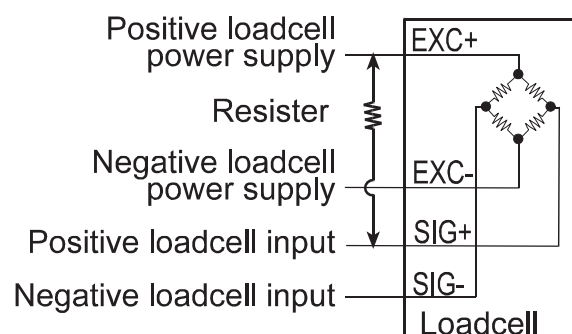

3.3.1. Verifying Loadcell Output and Input Sensitivity

The input sensitivity of the indicator is 0.3µV/division or more. Adapt to the following inequality, when you design a weighing instrument using the indicator and loadcell(s).

Caution

- A change in input voltage sensitivity is equivalent to a single division change of the display. Select as large an input voltage sensitivity voltage as possible so that the weighing interval becomes stable.
- Consider the leverage if a lever is used.

Weighing instrument using one loadcell.	$0.3 \leq \frac{E * B * D}{A}$	A: Rated capacity of loadcell [kg] B: Rated output [mV/V] D: Weighing interval [kg]
Weighing instrument using multi-loadcell	$0.3 \leq \frac{E * B * D}{A * N}$	E: Excitation voltage [mV] N: Number of loadcells

Verification Example

Design:		
Loadcell	N=1	
Rated capacity	A=750 [kg]	$\frac{5000 * 3 * 0.05}{750} = 1 \geq 0.3$ Therefore, regard the instrument as a good design.
Rated output	B=3 [mV/V]	
Excitation voltage	E=5000 [mV]	
Weighing interval	D=0.05 [kg]	
Weighing capacity	300 [kg]	



3.4. Wiring the Power Cord

Caution

- Ground the indicator using terminal E to avoid receiving an electric shock or an error due to discharge of static electricity.
 - Do not share the ground wire with an electrical device that generates noise.
 - Do not use an unstable power source.
 - Do not share the power cord with a motor system (a noise-generating device) to avoid operation error.
-
- The power source can be from AC 85V to AC 250V with 50 Hz or 60 Hz.

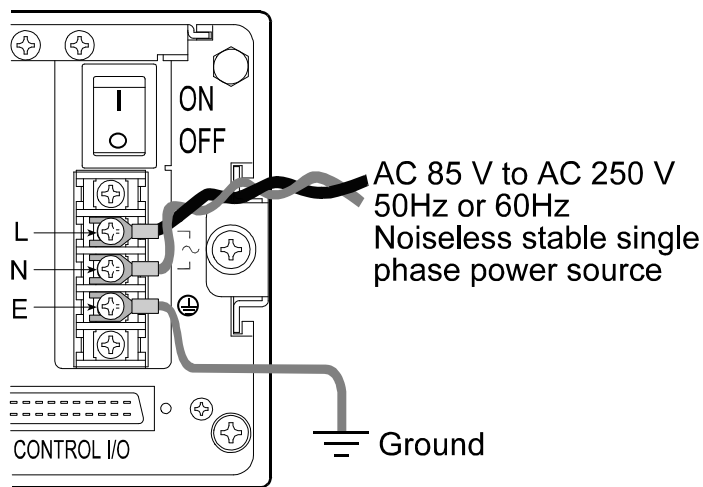

Adaptable Compression Terminal Parts

- Use the appropriate compression terminal parts to attach the cables.





4. Basic Operation



4.1. Key Operation Examples

- This section describes how to use key operation.

Caution The key operation immediately affects to the status of the indicator. Always check the keys to select before proceeding.

4.1.1. Standby Mode

OFF	Press and hold the OFF key about three seconds in the weighing mode. Then the indicator enters the standby mode and displays the standby indicator. In the standby mode, All interface circuits are turned off and only the internal circuits work.
ON	The ON key is used to turn on the indicator.

4.1.2. Cursor Operation

There is a cursor on a segment (an item) that is turned on and off.

↔	The ↔ key is used to move the cursor forward.
SHIFT + ↔	Press and hold the SHIFT key and press the ↔ key to move the cursor backward.
ENTER	The ENTER key is used to enter the selected item.
ESC	The ESC key is used to return to the previous mode and to undo the last key operation.

4.1.3. Inputting Characters

A character can be input in a current segment (an item) in the appropriate mode.

A/a	The A/a key is used to change numerical key, upper keys, lower keys and alphabetical key..
Alphanumerical	The alphanumerical keys and the ENTER key are used to enter the parameters and to select a code number directly.
ENTER	The ENTER key is used to specify the alphanumerical data.
ESC	The ESC key is used to undo the last key operation and to return to the previous mode.

4.1.4. Calling a Code

Step 1 Press the **CODE RECALL** key in either operation mode or normal stop mode.

Step 2 Set the code number with the following keys:

↕	The ↕ key is used to increase the code number.
SHIFT + ↕	Press and hold the SHIFT key and press the ↕ key to decrease the code number.
Numerical	The numerical keys and the ENTER key is used to select a code number directly and to enter the parameters.
ENTER	The ENTER key is used to specify the number.
ESC	The ESC key is used to undo the last key and to return to the previous mode.

4.1.5. Entering a Correction Mode

Step 1 Press and hold the **SHIFT** key and press the **CODE RECALL** key in the operation mode or normal stop mode.

Step 2 Select the code number using the following keys:

↕, SHIFT + ↕, Numerical, ENTER, ESC keys

Step 3 Edit some items of the code using the **numerical** and **ENTER** keys.

Step 4 Press the **ESC** key to return to the previous mode.

4.1.6. Entering The Menu

Step 1 Press and hold the **ENTER** key and press the **↕** key in either operation mode or normal stop mode.

Then the first layer of the menu is displayed.

Step 2 Use the following keys in the menu :

↕, SHIFT, Alphanumerical, A/a, ENTER, ESC keys

Step 3 Press the **ESC** key several times to return to normal stop mode.



4.2. Status Chart

4.2.1. Mode Map and Menu

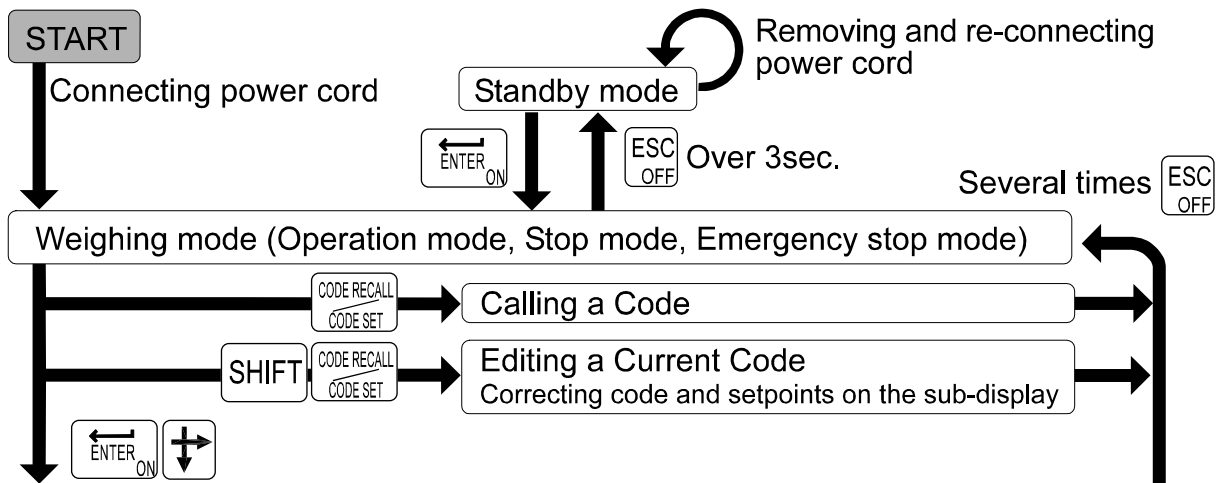

Outline of Menu

Code Edit	<ul style="list-style-type: none"> Edit Search Delete ——— Total, Setpoints and Total, All Totals, All Codes Copy Tare
CAL <i>Calibration</i>	<ul style="list-style-type: none"> CAL ——— Unit, Decimal point, Division, Capacity, Zero input, Mass value, Span input G ——— Gravity Acceleration Correction
Function <i>Parameters List</i>	<ul style="list-style-type: none"> Reference Function <ul style="list-style-type: none"> General ——— Weight, Sub display, Others Sequence ——— Basic, Control I/O, Timer, Zero track, Others Control I/O ——— Input, Output Serial ——— C. Loop, RS-485 Option ——— Slot 1, Slot 2, Slot 3 Set Function <ul style="list-style-type: none"> General ——— Weight, Sub display, Others Sequence ——— Basic, Control I/O, Timer, Zero track, Others Control I/O ——— Input, Output Serial ——— C. Loop, RS-485 Option ——— Slot 1, Slot 2, Slot 3
Check	<ul style="list-style-type: none"> Monitor Mode <ul style="list-style-type: none"> Control I/O C. Loop ——— <i>Current Loop</i> RS-485 A/D ——— <i>Internal AD count</i> Option ——— Slot 1, Slot 2, Slot 3 Test Mode <ul style="list-style-type: none"> Control I/O C. Loop ——— <i>Current Loop</i> RS-485 A/D ——— <i>Internal counts</i> Option ——— Slot 1, Slot 2, Slot 3
SystemMgmt <i>System Management</i>	<ul style="list-style-type: none"> Init <i>Initialization</i> <ul style="list-style-type: none"> RAM Code Function CAL All Remote Setup <ul style="list-style-type: none"> Data Software

Use , ,  principally.

4.2.2. Status of Weighing Mode

- Weighing mode comprises of the following modes.
- **Operation mode** includes the following check weighing (weighing sequence).
 - Automatic mode
 - Conveyor stop mode
 - OK mode
 - Manual mode
 - Simple mode
- The normal **stop mode** displays the current weighing value.
Use this mode generally to enter parameters of the function list into the indicator.
- The **emergency stop mode** assumes that the preset input terminal is connected to the emergency stop key.
- The "Input" means key operation, command from peripheral equipment or signal level of the preset input terminal.

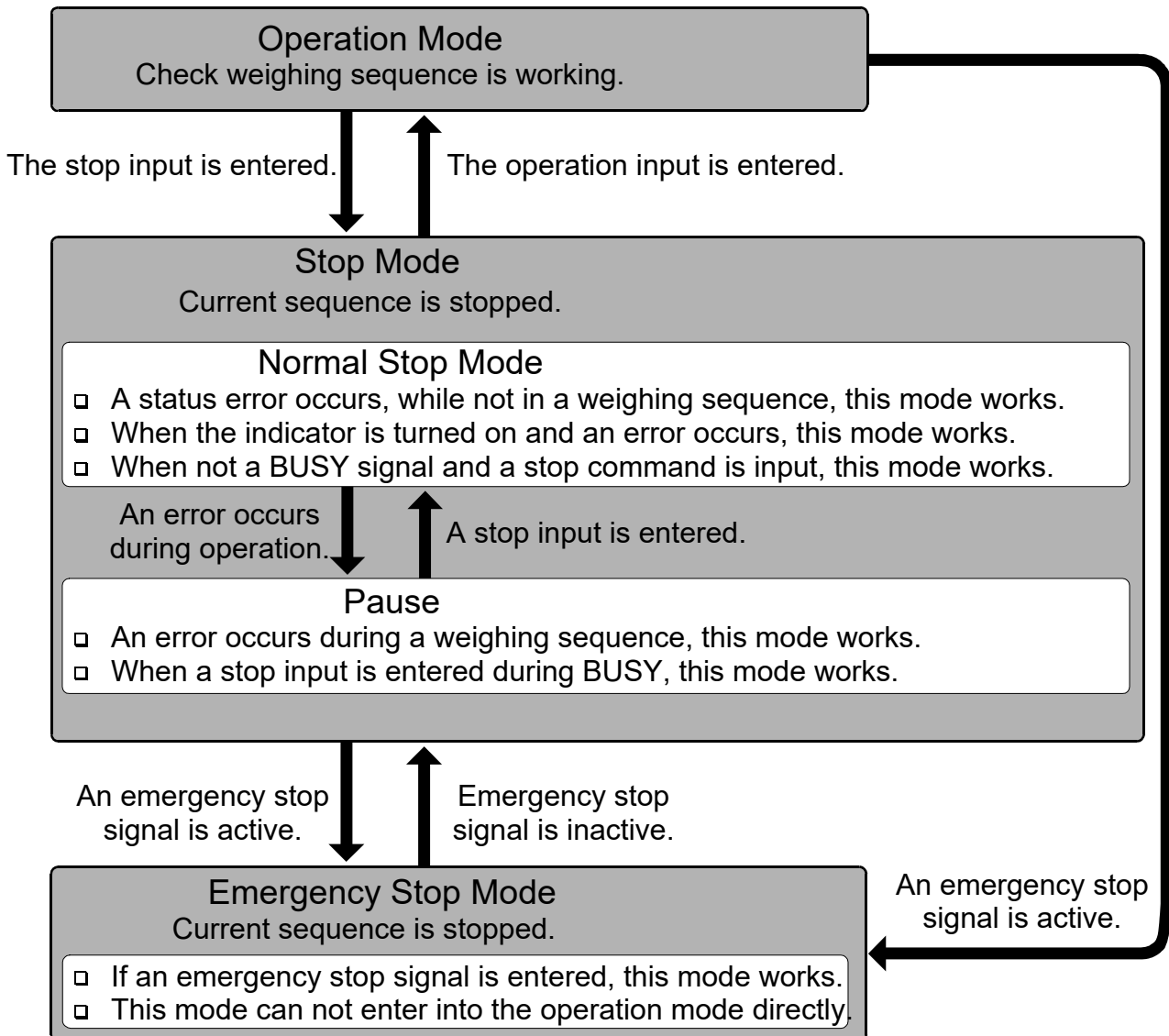



5. Calibration

- The indicator, which is connected to a loadcell unit, can weigh the "weight" value on the weighing conveyor and display its "mass" value. The calibration function is used to adjust the displayed value so that the weighing system can weigh correctly.
- There are two ways of calibration. The "**actual load calibration**" uses a rated mass and zero output from the loadcell unit. The "**digital span**" inputs arbitrary values (calculated by hand). These methods are selected in the calibration procedure.
- There is a compensation function of the "**gravity acceleration correction**". This function is used, when a calibrated weighing system is moved to another place.
- The indicator maintains the calibration parameters without any power supplied.

Common Calibration Items

Unit	The "g", "kg" and "t" or "lb" can be selected (lb: USA only).
Decimal point	The decimal point can be selected from "not used" to "four decimal places".
Minimum division	The minimum division of the weighing display.
Weighing capacity	The maximum mass that can be displayed.

Items for the "Actual Load Calibration"

Common items	Unit, decimal point, minimum division and weighing capacity
Zero point adjustment	A zero point output, from the loadcell unit, is used. (Zero calibration)
Span adjustment	A rated mass is placed on the weighing conveyor and is weighed. The sensitivity is adjusted. This sensitivity is the same as "sensitivity" of digital span. (Span calibration)

Items for "Digital Span"

Common items	Unit, decimal point, minimum division and weighing capacity
Zero point output	The numerical data is input as the zero point output of the loadcell unit.
Rated capacity	The rated capacity of the loadcell unit is input.
Sensitivity	The sensitivity of the loadcell unit is input.

Caution

- **When the CAL switch on the A/D board is "DISABLE", no calibration can be performed.**
- **Do not perform any calibration during a weighing sequence operation.**
- **Entering calibration mode during a weighing sequence operation, the weighing sequence operation is terminated. Calibrate the weighing system only when the weighing sequence operation has stopped**
- **The accuracy of the "Digital Span (Calibration without Mass)" is 1/1000 or less.**
- **Do not use a "loadcell summing box", when the "digital span" is performed.**
- **It is necessary that the loadcell sensitivity is known exactly, if the "digital span" is to be used.**



5.1. Actual Load Calibration (using a Mass)

- ESC** key If you want to return to the weighing mode during the calibration mode, press the **ESC** key anytime. It is effective until the last displayed parameter.
Example: zero adjustment only, etc.
- ENTER** key When the key is pressed, the procedure stores the current parameter and proceeds to the next step.

Common Calibration Items

- Step 1 Press and hold the **ENTER** key and press the **↔** key to display the menu in the normal stop mode.
- Step 2 Press the **↔** key to select the menu `CAL.`
Press the **ENTER** key to enter the calibration mode.
- Step 3 Press the **ENTER** key to enter the menu `CAL.`
- Step 4 Select a weighing unit using the numerical keys and press the **ENTER** key to store it.
- Step 5 Select a decimal point using the numerical keys and press the **ENTER** key to store it.
- Step 6 Select a minimum division using the numerical keys and press the **ENTER** key to store it.
- Step 7 Select a weighing capacity using the numerical keys and press the **ENTER** key to store it.
- Step 8 If the **F1** key is pressed, it will branch out to the digital span.

Items for the "Actual Load Calibration"

- Step 9 The Zero Point Adjustment
Place nothing on the weighing conveyor and press the **ENTER** key to store the zero point after the **STABLE** indicator is displayed.
Whether the **STABLE** indicator is displayed or not, if you want to store it, wait for ten seconds and press the **ENTER** key.
- Step 10 Specify a total mass value to place on the weighing conveyor using the numerical keys and press the **ENTER** key to store it.
- Step 11 The Span Adjustment
Place the specified mass on the weighing conveyor and press the **ENTER** key to store it after the **STABLE** indicator is displayed.
Whether the **STABLE** indicator is displayed or not, if you need to store it, wait for ten seconds and press the **ENTER** key.
- Step 12 Press the **ESC** key to return to the normal stop mode.



5.2. Digital Span (Calibration without a Mass)

- ESC** key If you want to return to the normal stop mode during the calibration mode, press the **ESC** key anytime. It is effective until the last displayed parameter.
Example: zero adjustment only, etc.
- ENTER** key When the key is pressed, the procedure stores the current parameter and proceeds to the next step.

Common Calibration Items

- Step 1 Press and hold the **ENTER** key and press the \blacktriangleright key to display the menu in the normal stop mode.
- Step 2 Press the \blacktriangleright key twice to select the menu `CAL`.
Press the **ENTER** key to enter the calibration mode.
- Step 3 Press the **ENTER** key to enter the menu `CAL`.
- Step 4 Select a unit using the numerical keys and press the **ENTER** key to store it.
- Step 5 Select a decimal point using the numerical keys and press the **ENTER** key to store it.
- Step 6 Select a minimum division using the numerical keys and press the **ENTER** key to store it.
- Step 7 Select a weighing capacity using the numerical keys and press the **ENTER** key to store it.
- Step 8 Press the **F1** key to proceed to the next step.

Items for "Digital Span"

- Step 9 The Zero Point Adjustment
If the zero point value needs adjustment, input it using the numerical keys and press the **ENTER** key to store it.
If the zero point value does not need adjustment, press the **ENTER** key to proceed the next step.
- Step 10 The Span Adjustment
Input the rated capacity of the loadcell unit using the numerical keys and press the **ENTER** key to store it.
- Step 11 Input the sensitivity of the loadcell unit in the unit of mV/V using the numerical keys and press the **ENTER** key to store it.
- Step 12 Press the **ESC** key to return the normal stop mode.

Suggestion

The digital span can be used for trimming of the actual load calibration using a mass.



5.3. Gravity Acceleration Correction

- The function compensates for weighing error due to the difference of gravity acceleration.

G1 The place where the weighing system is calibrated.

G2 The place where the weighing system is used.

ESC key If you want to return to the normal stop mode during the calibration mode, press the **ESC** key anytime.

ENTER key When the key is pressed, the procedure stores a current parameter and proceeds to next step.

- Step 1 Press and hold the **ENTER** key and press the key to display the menu in the normal stop mode.
- Step 2 Press the key to select the menu **CAL**. Press the **ENTER** key to enter the calibration mode.
- Step 3 Select the menu with the key. Press the **ENTER** key to enter it.
- Step 4 Input the gravity acceleration at **G1** using the numerical keys and press the **ENTER** key to store it.
- Step 4 Input the gravity acceleration at **G2** using the numerical keys and press the **ENTER** key to store it.
- Step 5 Press the **ESC** key to return the normal stop mode.

5.3.1. Gravity Acceleration Reference

Amsterdam	9.813 m/s ²	Manila	9.784 m/s ²
Athens	9.800 m/s ²	Melbourne	9.800 m/s ²
Auckland NZ	9.799 m/s ²	Mexico City	9.779 m/s ²
Bangkok	9.783 m/s ²	Milan	9.806 m/s ²
Birmingham	9.813 m/s ²	New York	9.802 m/s ²
Brussels	9.811 m/s ²	Oslo	9.819 m/s ²
Buenos Aires	9.797 m/s ²	Ottawa	9.806 m/s ²
Calcutta	9.788 m/s ²	Paris	9.809 m/s ²
Chicago	9.803 m/s ²	Rio de Janeiro	9.788 m/s ²
Copenhagen	9.815 m/s ²	Rome	9.803 m/s ²
Cyprus	9.797 m/s ²	San Francisco	9.800 m/s ²
Djakarta	9.781 m/s ²	Singapore	9.781 m/s ²
Frankfurt	9.810 m/s ²	Stockholm	9.818 m/s ²
Glasgow	9.816 m/s ²	Sydney	9.797 m/s ²
Havana	9.788 m/s ²	Tainan	9.788 m/s ²
Helsinki	9.819 m/s ²	Taipei	9.790 m/s ²
Kuwait	9.793 m/s ²	Tokyo	9.798 m/s ²
Lisbon	9.801 m/s ²	Vancouver, BC	9.809 m/s ²
London (Greenwich)	9.812 m/s ²	Washington, DC	9.801 m/s ²
Los Angeles	9.796 m/s ²	Wellington, NZ	9.803 m/s ²
Madrid	9.800 m/s ²	Zurich	9.807 m/s ²

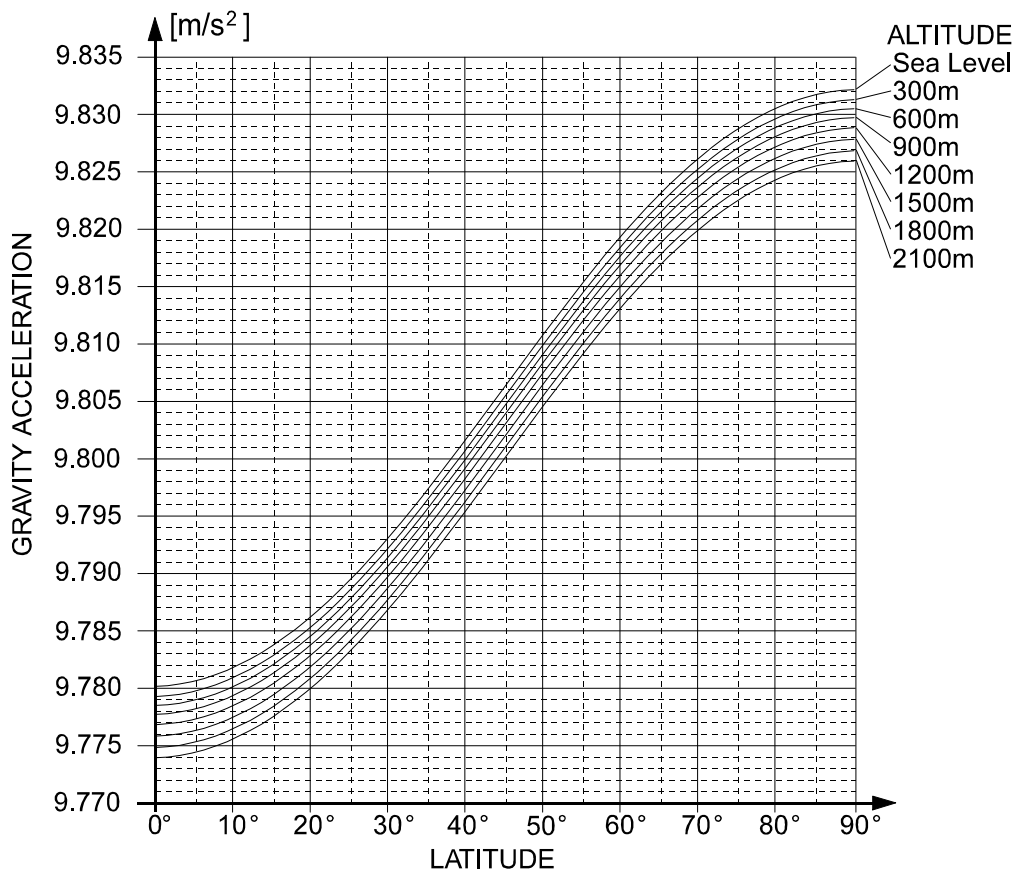

5.4. Calibration Error

Error Code	Error Status and Solution
CERR1	Resolution (Weighing capacity / minimum division) exceeds the limitation. Increase minimum division or decrease weighing capacity.
CERR2	The initial load (no load output) is larger than 2mV/V. Check the weighing conveyor, loadcell unit and cable.
CERR3	Negative loadcell output value. Check the weighing conveyor, loadcell unit and cable.
CERR4	Mass value exceeds the weighing capacity. Use a mass within the weighing capacity. (Decrease mass value)
CERR5	Mass value is too light for the calibration. Increase mass value.
CERR6	The loadcell output to be equivalent to the minimum division is too small. Use a greater minimum division.
CERR7	The polarity of the loadcell output is reversed. Check the loadcell cable.
CERR8	The mass value of the weighing capacity exceeds 3.2 mV/V. Confirm the mass and weighing capacity.
CERR9	Gravity acceleration is out of range. Correct the value within the range of 9.770 ~ 9.835 m/s ² .
CERR10	Zero output of the loadcell unit is out of range. Trim the zero output within 0.0 ~ 2.0 mV/V.
CERR11	The loadcell output to be equivalent to minimum division is out of range. Trim the output within 0.0 ~ 3.2 mV/V.

[Blank page]



6. Check Weighing Sequence



6.1. Automatic Mode (weighing in motion)

- The mode weighs and classifies (judges or checks) the weight of an article, when it passes it on the weighing conveyor. The article does not stop on the weighing conveyor.
- Refer to "6.5. Judgement and Selector Action" for the selector action.
- When gross value is within the zero band at judgement, it is ignored as a weighing error, like touching the sensor or conveyor.
- The mode can be used with **foreign matter detection**.

Concerning Principal Items (Including Parameter Example)

Address Parameter	Address name Parameter name	Description
59 F-01 1	Weighing mode Automatic mode	
59 F-02 1	Selection of comparison 3 levels with target	Setpoints and comparison method Target, Lo (light), Hi(heavy)
59 F-29 1	Detector Top edge	Detection method Position sensor detects the front of an article.
59 F-05 11011111	Buzzer condition 1	Buzzer sounds without OK. 1: buzzer sounds, 0: no buzzer
59 F-21 00000110	Conveyor stop condition	Conveyor stops for foreign matter or crush.
59 F-22 11011111	Selector 1 condition	Article is separated by selector 1 without OK.
59 F-42	Chattering timer	The time to ignored position sensor. Range is 0.00 to 99.99 sec.
59 F-43	Eval delay timer	The time between detecting an article and averaging it. Range is 0.00 to 99.99 sec.
59 F-44	Average timer	Time to average the weighing value. Range is 0.00 to 99.99 sec.
59 F-45 000	Compare Output timer	Output pulse is turned on until next article detection. Range is 0.00 to 99.99 sec.
59 F-46	Selection out 1 delay timer	Delay time of selector 1 after judgement. Range is 0.00 to 99.99 sec.
59 F-52	Select output 1 timer	The output time of selector 1. Range is 0.00 to 99.99 sec.

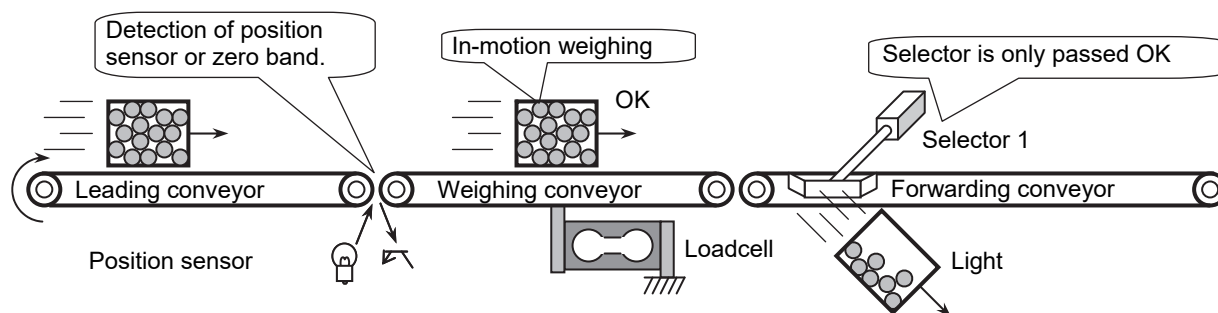

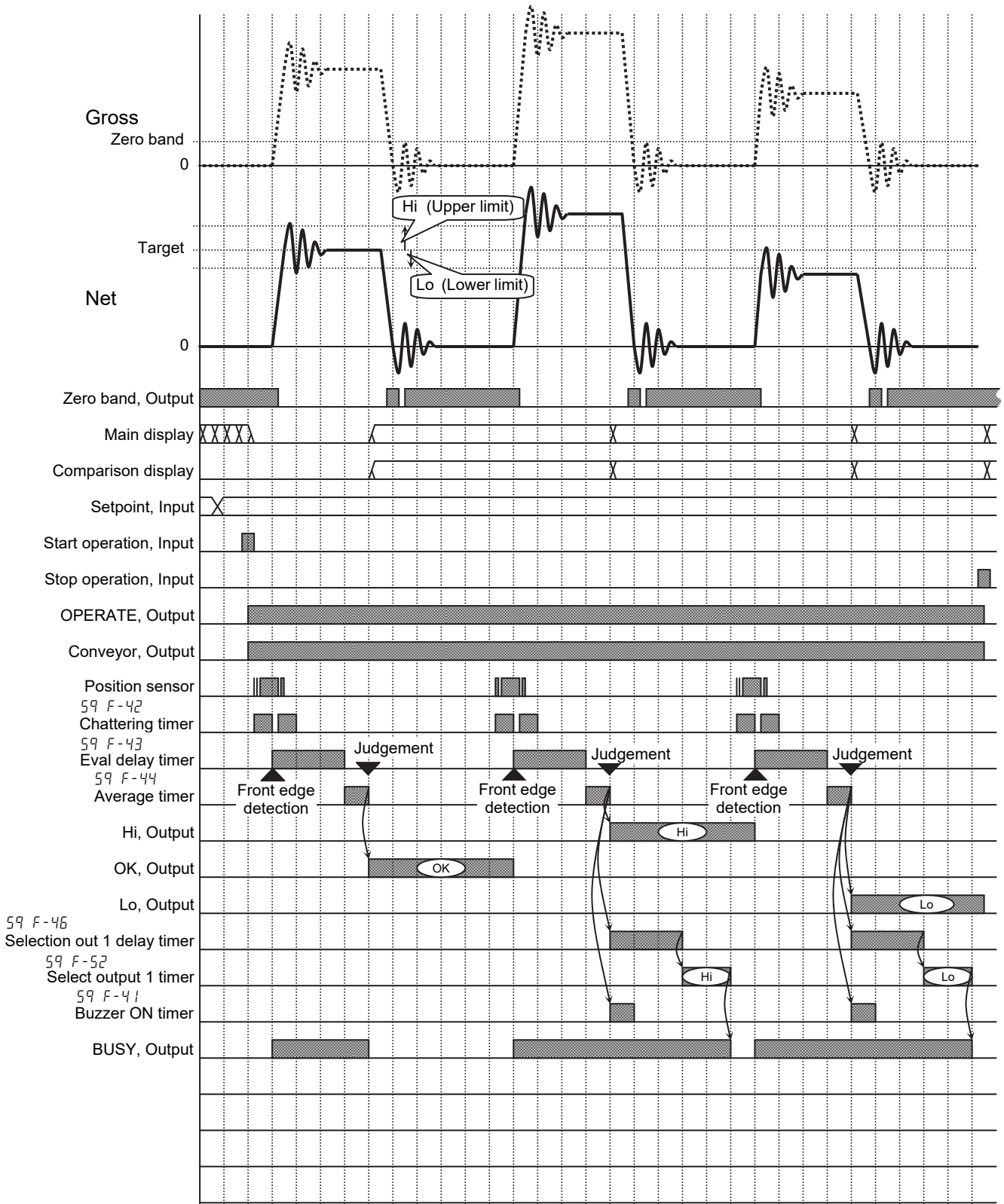

Drawing: Automatic Mode



6.2. Conveyor Stop Mode

- The **conveyor stop mode** is the function that the article is stopped on the weighing conveyor for accurate measurement.
- When the gross value is within zero band, the weighing value is not judged.
- The mode can be used with **foreign matter detection**.

Caution

- **Set parameter of Tail Edge to place the article on the weighing conveyor correctly.**

[59 F-29] [2] [Function] - [Set Function] - [Sequence] - [Control] - [Tail Edge]

Concerning Principal Items (Including Parameter Example)

Address Parameter	Address name Parameter name	Description
59 F- 1 2	Weighing mode Conveyor stop mode	
59 F- 2 1	Selection of comparison 3 levels with target	Setpoints and comparison method Target, Lo (light), Hi(heavy)
59 F-29 2	Detector Tail edge	Detection method Position sensor detects the end of an article.
59 F- 5 11011111	Buzzer condition 1	Buzzer sounds without OK. 1: buzzer sounds, 0: no buzzer
59 F-21 00000110	Conveyor stop condition	Conveyor stops for foreign matter or crush.
59 F-22 11011111	Selector 1 condition	Article is separated by selector 1 without OK.
59 F-42	Chattering timer	The time to ignore the position sensor. Range is 0.00 to 99.99 sec.
59 F-43	Eval delay timer	The time between detecting an article and averaging it. Range is 0.00 to 99.99 sec.
59 F-44	Average timer	Time to average the weighing value. Range is 0.00 to 99.99 sec.
59 F-45 000	Compare Output timer	Output pulse is turned on until next article detection. Range is 0.00 to 99.99 sec.
59 F-46	Selection out 1 delay timer	Delay time of selector 6 after judgement. Range is 0.00 to 99.99 sec.
59 F-52	Select output 1 timer	The output time of selector 1. Range is 0.00 to 99.99 sec.

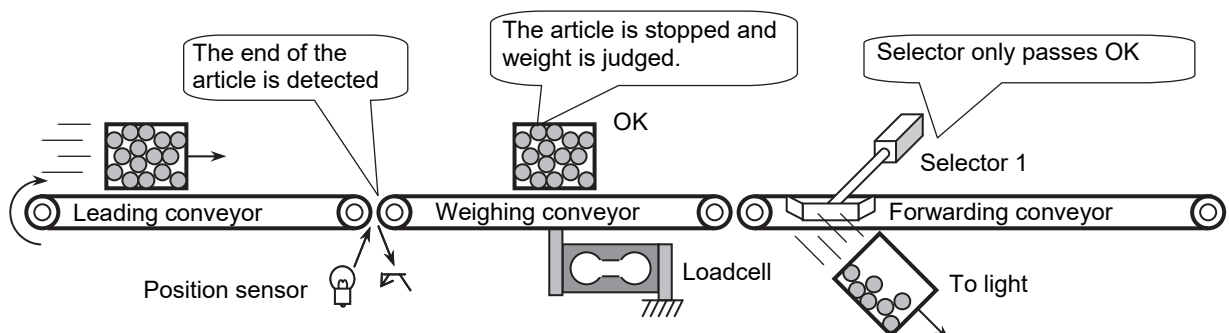

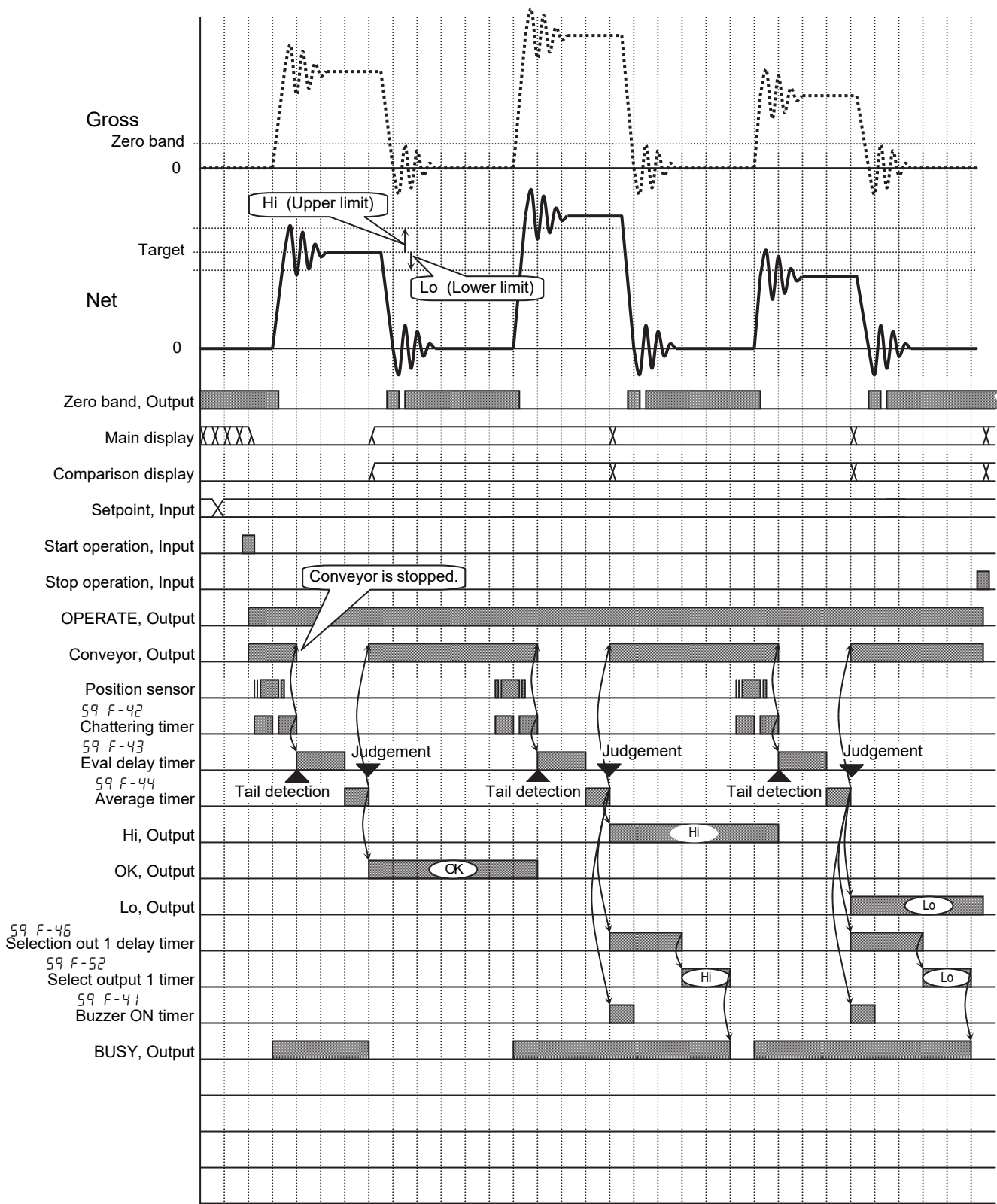

Drawing: Conveyor Stop Mode



6.3. Foreign Matter Detection

- The **foreign matter detection** is the function to reject an article including foreign matter.
- The system consists of the AD-4404 and the foreign matter detector.
- The rejection is performed with the following procedure.
 - 1 When an article including foreign matter is detected, a signal is transmitted from the foreign matter detector to a preset I/O control interface terminal of the AD-4404.
 - 2 When the AD-4404 receives the signal, the Foreign detect timer [59 F-58] starts.
 - 3 When the timer is up, the current weighing value is ignored. Judgement is regarded as fault. Rejection signal is transmitted from the AD-4404 to the selector.
 - 4 The article is rejected with the selector.
- The function can be used with **automatic mode** and **conveyor stop mode**.

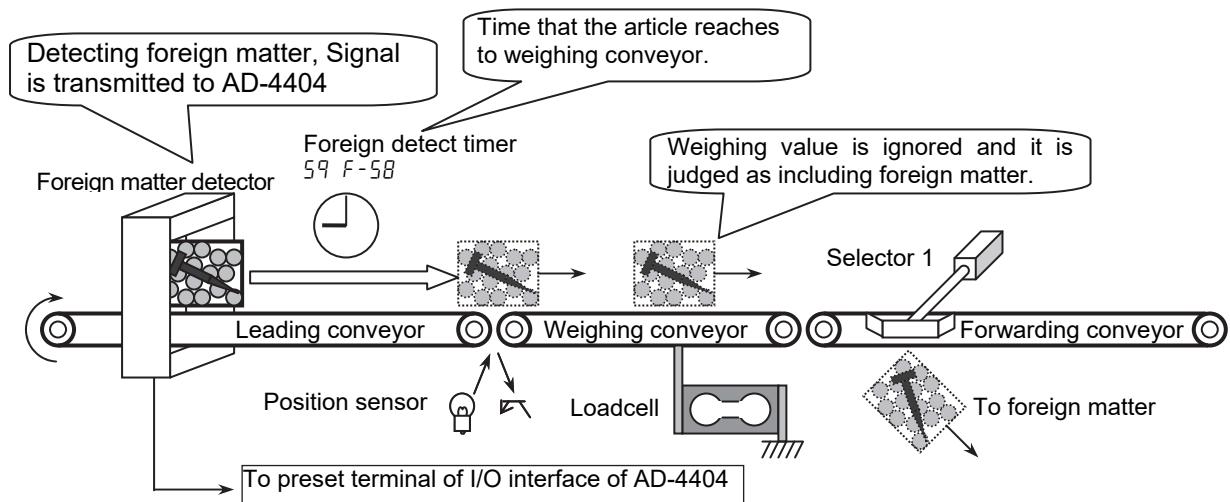

Concerning Principal Items (Including Parameter Example)

Address Parameter	Address name Parameter name	Description
1n F- 10 9	IN 10(A10) function Foreign matter detection	Terminal A10 of the I/O interface is used as detection input.
59 F-58	Foreign detect timer	Delay time that the article moves from the detector to the weighing conveyor. Range is 0.00 to 99.99 sec.
59 F- 1 1 or 2	Weighing mode Automatic mode or Conveyor stop mode	
Refer to Automatic mode or Conveyor stop mode for other items		

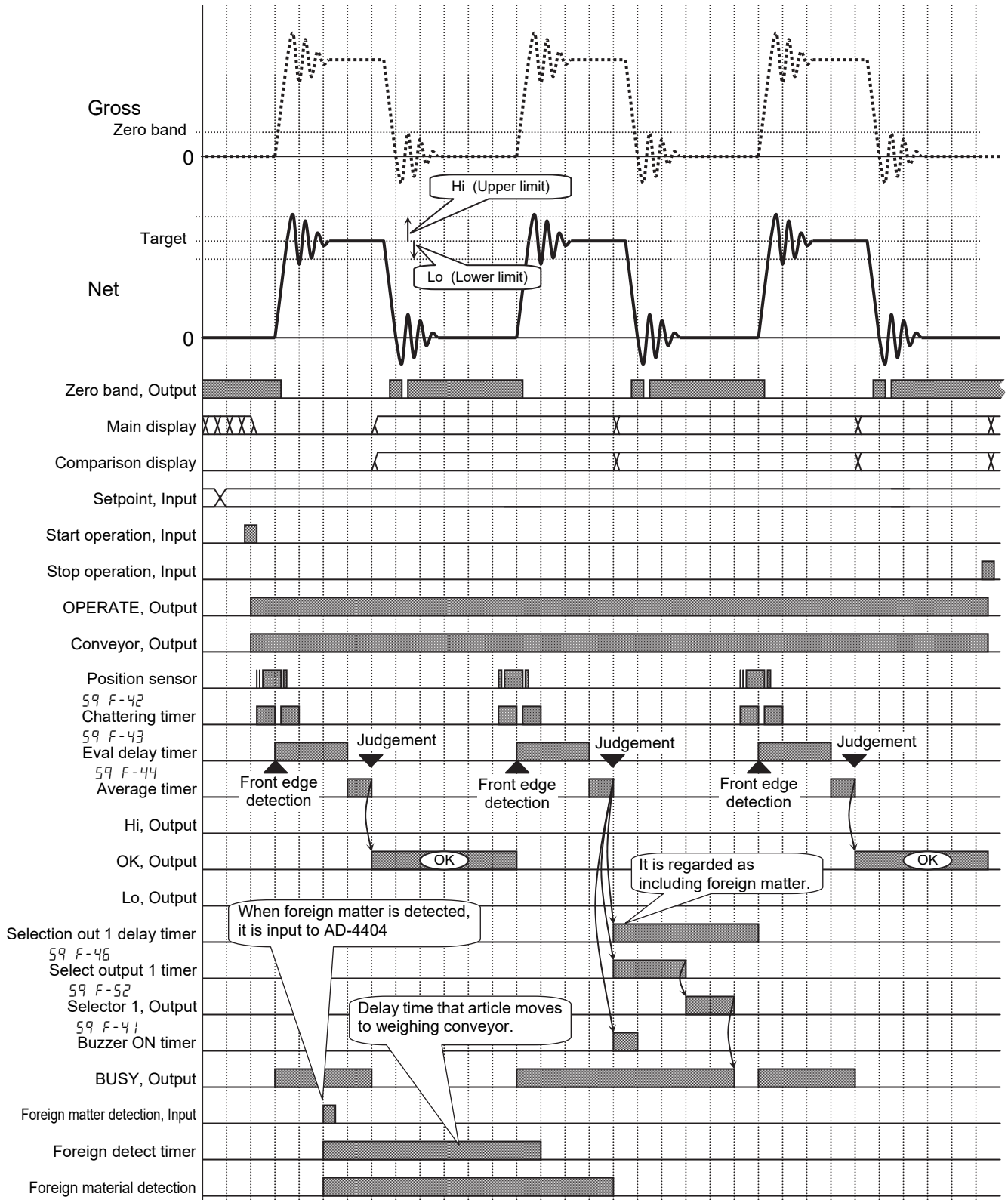

Drawing: Foreign Matter Detection



6.4. OK Mode

- The procedure of **OK mode** is as follows:
 - 1 Put the article on the stopped weighing conveyor.
 - 2 Pack the elements into the article by hand.
 - 3 Press the **START** key. When the weighing value is OK, the article can be moved out.
- The mode can be used with the buzzer according to the preset parameters.
- In the stop mode, the current weighing value and the comparison display is always updated. The comparison output is turned off. The buzzer and the comparison display are turned off when the weighing value is within the zero band.
- In the beginning of the operation mode, the display is reset and the buzzer becomes silent. When **Eval delay timer [59F-43]** is up, averaging and judgement is performed.
- When the result is OK, the preset OK terminal is turned on.
- When judgement is achieved, the weighing value and the comparison result are held, the conveyor output is turned on and the article is moved out.
- When **Conveyor stop delay timer [59F-59]** is up, the hold display is canceled, comparison output and conveyor output are turned off.
- When the result is not OK, the comparison is achieved and the display is held until **Conveyor stop delay timer [59F-59]** is up.
- The mode does not use any selector.

Caution

- **The buzzer is used for hand operation support with the following AND condition.**
 - 1 **While stopping conveyor.**
 - 2 **Gross value is not within zero band.**
 - 3 **Buzzer condition 1 [59F-5] to Buzzer condition 6 [59F-10] are already preset.**

Concerning Principal Items (Including Parameter Example)

Address Parameter	Address name Parameter name	Description
59 F- 1 3	Weighing mode OK mode	
59 F- 2 1	Selection of comparison 3 levels with target	Setpoints and comparison method Target, Lo (light), Hi(heavy)
59 F-29 2	Detector Tail edge	Detection method Position sensor detects the end of an article.
59 F- 6 0 1000000	Buzzer condition 2	Buzzer sounds at Lo. Interval is 0.5Hz. 1: buzzer sounds, 0: no buzzer
59 F- 8 00 100000	Buzzer condition 4	Buzzer sounds at OK. Interval is 2Hz. 1: buzzer sounds, 0: no buzzer
59 F- 10 000 10000	Buzzer condition 6	Buzzer sounds at Hi. Interval is 8Hz. 1: buzzer sounds, 0: no buzzer
59 F-41 500	Buzzer ON timer	Range is 0.00 to 99.99 sec. 5.00 seconds
59 F-59	Conveyor stop delay timer	The delay timer of conveyor after judgement. Range is 0.00 to 99.99 sec.

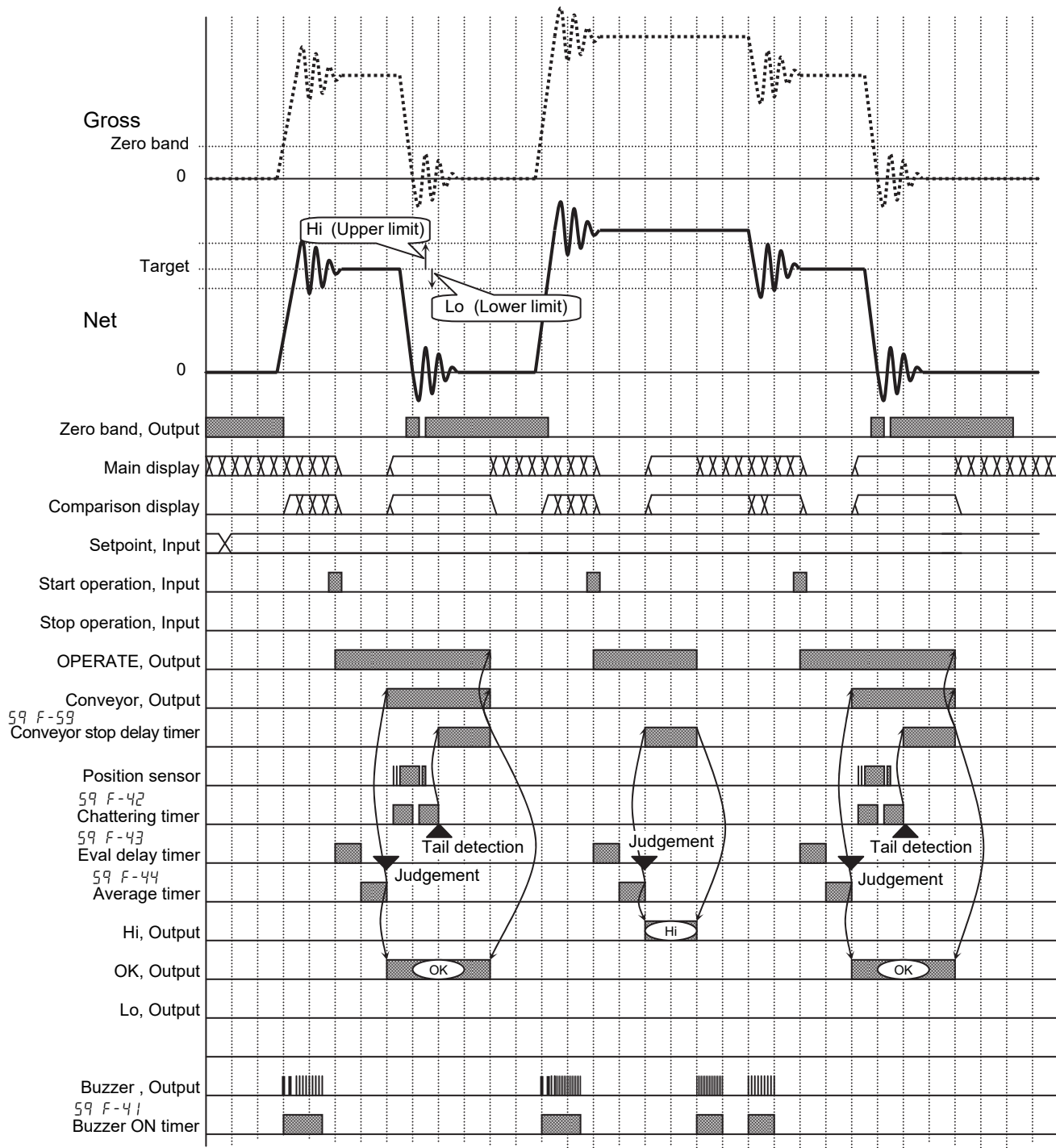

Drawing: OK Mode

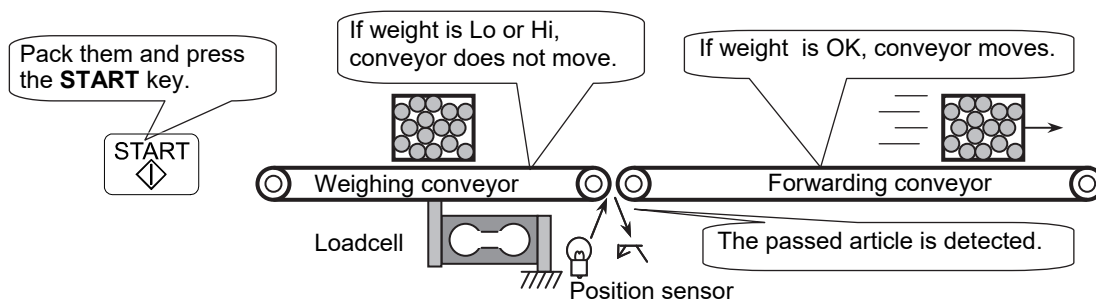



6.5. Manual Mode

- The **manual mode** is the mode that weighs the article by hand operation and does not use a conveyor.
- In the stop mode, the current weighing value and comparison display are always updated. The comparison output and buzzer are turned off. The comparison display is turned off, when the weighing value is within zero band.
- In the operation mode, the current weighing value is updated.
- The detection of the article uses the weighing value that crosses from the zero band and **Detector [59 F-29]** is not used.
- The weighing procedure is as follows:
 - 1 The comparison display, comparison output and buzzer are turned off, when the weighing value is within the zero band.
 - 2 When the article is weighed, the weighing display blinks once.
 - 3 Eval delay timer [59 F-43] and Average timer [59 F-44] are up.
 - 4 The weight is judged.
 - 5 The comparison result is output and the preset buzzer sounds.
 - 6 The weighing value and the comparison display are held.
 - 7 When the article is removed and the weighing value is within the zero band, the hold display is canceled, comparison output and buzzer are canceled.

Concerning Principal Items (Including Parameter Example)

Address Parameter	Address name Parameter name	Description
59 F-01 4	Weighing mode Manual mode	
59 F-02 1	Selection of comparison 3 levels with target	Setpoints and comparison method Target, Lo (light), Hi(heavy)
59 F- 6 0 1000000	Buzzer condition 2	Buzzer sounds at Lo. Interval is 0.5Hz. 1: buzzer sounds, 0: no buzzer
59 F- 8 00 100000	Buzzer condition 4	Buzzer sounds without OK. Interval is 2Hz. 1: buzzer sounds, 0: no buzzer
59 F- 10 000 10000	Buzzer condition 6	Buzzer sounds at Hi. Interval is 8Hz. 1: buzzer sounds, 0: no buzzer
59 F-41 500	Buzzer ON timer	Range is 0.00 to 99.99 sec. 5.00 seconds

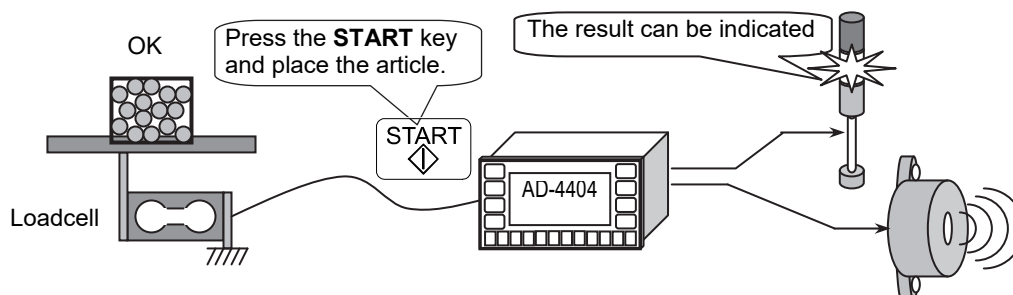

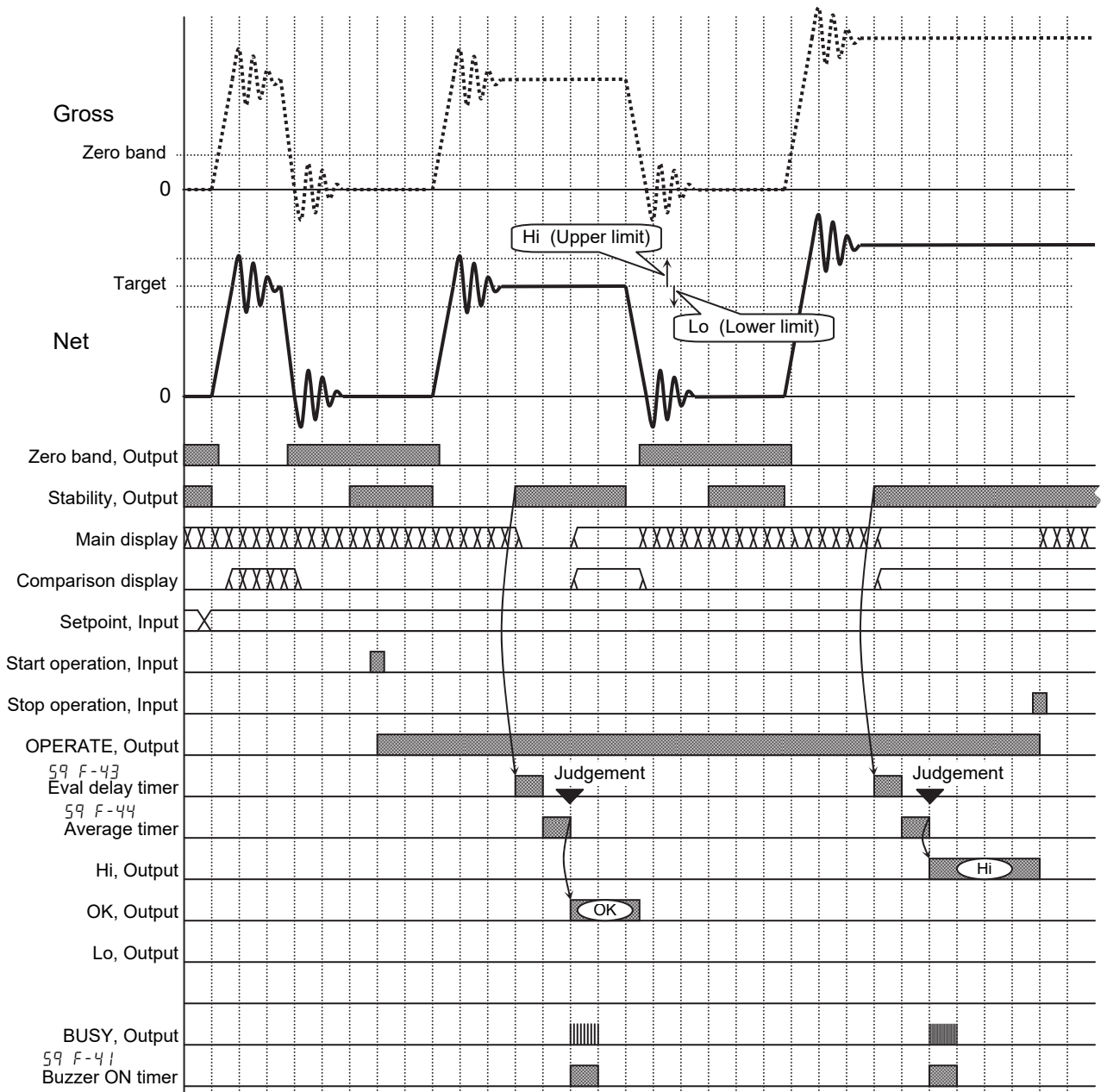

Drawing: Manual Mode



6.6. Simple Mode

- The **simple mode** is used to compare the weighing value and the setpoints.

Setpoints, means preset value to be used comparison, are used for buzzer, comparison display and output. There are five setpoints of LoLo, Lo, OK, Hi, HiHi.
- The current weighing value and the comparison display are always updated. The comparison display, the comparison output and buzzer are turned off, when the weighing value is within the zero band.
- Accumulation, is achieved at judgement, ignores stop mode and operation mode, and is not achieved at pause.

Concerning Principal Items (Including Parameter Example)

Address Parameter	Address name Parameter name	Description
59 F-01 5	Weighing mode Simple mode	
59 F-02 1	Selection of comparison 3 levels with target	Setpoints and comparison method Target, Lo (light), Hi(heavy)
59 F- 5 11011111	Buzzer condition 1	Buzzer sounds without OK. 1: buzzer sounds, 0: no buzzer

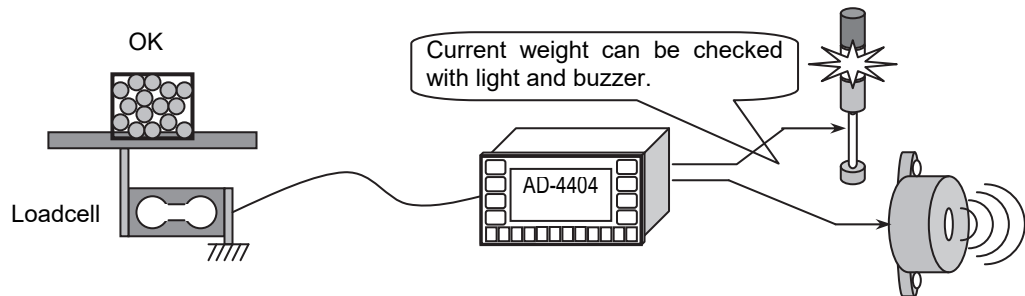

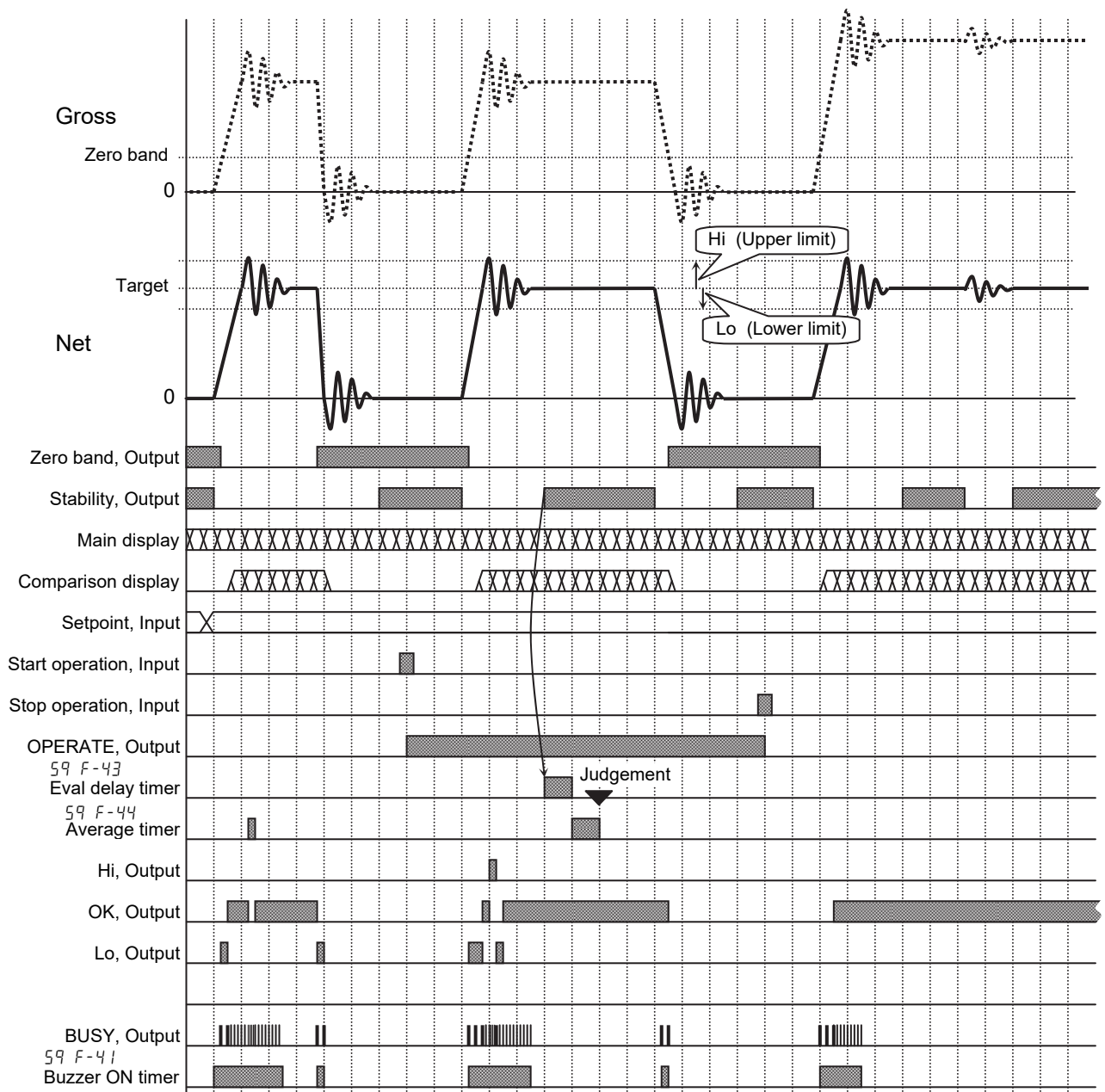

Drawing: Simple Mode



6.7. Status and Check Weighing Sequence

- The status of the indicator, the display and each interface are according to the status of the check weighing sequence.
- Preset a parameter for each terminal function in the menu Control I/O.
 - [In F- 1] to [In F- 11] Function] - [Set Function] - [Control I/O] - [Input]
 - [Out F- 1] to [Out F- 11] Function] - [Set Function] - [Control I/O] - [Output]

Principal Status List

Location and function name.....	Control output or output terminal Conveyor (14)
In normal stop mode	Conveyor is stopped.
In operation mode	
For automatic mode, conveyor stop mode, OK mode	It is moving.
For manual mode and simple mode	It is stopped.
In pause	It is stopped.
Location and function name.....	Status indicator OPERATE
In normal stop mode	It turns off.
In operation mode	It turns on.
In pause	It blinks.
Location and function name.....	Status indicator and Control output Hi, OK, Lo (Comparison result)
In normal stop mode	
For automatic mode, conveyor stop mode	It turns off.
For manual mode, OK mode, simple mode	It displays result for the current weight.
In operation mode	
For automatic mode, conveyor stop mode	It displays result.
For manual mode, OK mode.....	It turns off before judgement. It displays result after judgement.
For simple mode	It displays result for the current weight.
In pause	It displays result.
Location and function name.....	Status indicator ZTR (Zero tracking)
In normal stop mode	It displays for one second, when static zero tracking is achieved.
In operation mode	It displays for one second, when static or dynamic zero tracking is achieved
In pause	It displays for one second, when static zero tracking is achieved.

Location and function name.....	Status indicator 0.BAND (Zero band)
In normal stop mode, operation mode, pause.....	It displays judgement whether the weighing value is within zero band.
Location and function name.....	Status indicator D.COMP (Dynamic compensation)
In normal stop mode	It turns off.
In operation mode	It displays, when coefficient is not 1.
In pause	It is turned off.
Location and function name.....	Weighing value
In normal stop mode	It displays gross or net.
In operation mode	It displays, when coefficient is not 1.
For automatic mode, conveyor stop mode.....	It displays and holds net of result.
For manual mode.....	Net is displayed before judgement. It displays result after judgement.
For OK mode	It turns off before judgement. It displays result after judgement.
For simple mode	Gross or net is displayed.
In pause.....	Gross or net is displayed.
Location and function name.....	Upper side of graphic status indicator
In normal stop mode	
For automatic mode, conveyor stop mode.....	It is turned off.
For manual mode, OK mode, simple mode	It displays result for the current weight.
In operation mode	
For automatic mode, conveyor stop mode.....	It displays result.
For manual mode, OK mode.....	It turns off before judgement. It displays result after judgement.
For simple mode	It displays result for the current weight.
In pause.....	It displays result.
In case of sequence error.....	Error number is displayed
Location and function name.....	Under side of graphic status indicator
In normal stop mode	It is not used.
In operation mode	
For automatic mode, conveyor stop mode, OK mode	It displays status of conveyor and weighing sequence.
For manual mode, simple mode	It is not used.
In pause.....	It is not used. O is displayed, when Force target finish [pthF-3] [7] is set to the F1 or F2 key.
Location and function name.....	Weighing unit indicator
In normal stop mode, operation mode, pause.....	Unit is displayed.

Location and function name.....	Graph indicator of sub-display
In normal stop mode	Graph of net is displayed.
In operation mode	
For automatic mode, conveyor stop mode	It displays and holds graph of result
For manual mode, OK mode.....	It turns off before judgement. It displays result after judgement.
For simple mode	It displays graph of net.
In pause	It displays graph of net. If there is error, an error message is displayed.
Location and function name.....	Gross of sub-display
In normal stop mode, operation mode.....	Gross is displayed.
In pause	Gross is displayed. If there is error, an error message is displayed.
Location and function name.....	Net of sub-display
In normal stop mode, operation mode.....	Net is displayed.
In pause	Net is displayed. If there is error, an error message is displayed.
Location and function name.....	Buzzer
In normal stop mode	
For automatic mode, conveyor stop mode, manual mode, OK mode.....	It turns off.
Simple mode in normal stop mode, operation mode and pause	It is according to the following parameters. Buzzer condition 1 [59 F-5] to Buzzer condition 6 [59 F-10] and Buzzer on timer [59 F-41]. When pressing the key preset Buzzer stop [In] [B], it stops sound.
Location and function name.....	Comparison output (HiHi, Hi, OK, Lo, LoLo)
In normal stop mode	
For automatic mode, conveyor stop mode, manual mode, OK mode.....	It turns off.
For simple mode	It is output judgement of the current weight.
In operation mode	
For automatic mode, conveyor stop mode, manual mode	It is output judgement.
For OK mode	It turns off.
For simple mode	It is output judgement of the current weight.
In pause	It is output judgement.

Location and function name.....	Selector output (HiHi, Hi, OK, Lo, LoLo)
In normal stop mode	It turns off.
In operation mode	
For automatic mode, conveyor	
stop mode.....	It is according to the following parameters.
	Selection out 1 delay timer [59 F-46] to
	Selection out 6 delay timer [59 F-51],
	Select output 1 timer [59 F-52] to
	Select output 6 timer [59 F-57]
For , manual mode, OK mode,	
simple mode	It turns off.
In pause.....	When entering into pause, output is held.
	When returning to operation, output is continued.



7. Code

- The code is necessary to weigh the article and is commonly used in all modes.
- The AD-4404 can store 100 set of codes without any power supply.
- When recalling a code in this mode, the code can be used.
- There are two ways to operate the code.
 - The way to edit principal parameters of the code in the sub-display.
 - The way to operate (Edit, Search, Delete, Copy, Tare) the code in menu Code Edit.
- Select a backup method of code at Save data [0thF-B].
- If Save in flash memory [0thF-B] [2] is selected, when opening menu Code Edit, the current sequence is stopped.
 - [Function] - [Set function] - [General] - [Others] - [Save data]
- Select a method to recall the code at Code recall method [59F-B 1].
 - [Function] - [Set function] - [Sequence] - [Others]
- Each code stores the following parameters.
 These parameters can be accessed at the menu Edit of Code Edit.

Display Symbol	Item Name and Description
Code **	Code number ** is 0 to 99.
Name	Name 12 characters
Target	Target weight
Hi	High limit
Lo	Low limit
HiHi	High-high limit
LoLo	Low-Low limit
Zero Band	Zero band
Full	Full filling
PT	Preset Tare
Tgt#	Target count The number to stop the conveyor.
Tot#	Total count Total number that judged weighing.
OK#	OK count Lo ϕ weight ϕ Hi
NG#	NG count weight ϕ Lo or Hi ϕ weight
Hi#	Hi count Hi < weight ϕ HiHi or Hi < weight
Lo#	Lo count LoLo ϕ weight < Lo or weight < Lo
HiHi#	HiHi count HiHi < weight
LoLo#	LoLo count weight < LoLo
FMD#	Foreign matter detection count
Duplication#	Duplication count
Crush#	Crush count
Max	Maximum
Min	Minimum
Average	Average
STD	Standard deviation σ_{n-1}
STDP	Population standard deviation σ_n
Total	Total of the weighing value



7.1. Use of the Code

7.1.1. Recalling a Code

- A preset code can be recalled to use it always.

Caution If the code number is changed during operation, the I/O status is changed, too.

Step 1 Press the **CODE RECALL** key.

Step 2 Enter code number using the **numerical** keys. Press the **ENTER** key to recall it.
Then the I/O status and the display are changed.

7.1.2. Editing a Code in the Sub-display

- The setpoints, LoLo, Lo, Target, Hi and HiHi can be edited in the sub-display always. Refer to Selection of comparison [59 F-2] for selection of setpoint.
[Function] - [Set function] - [Sequence] - [Basic] - [Selection of comparison]
- Preset sub-display form to edit setpoints.
[Function] - [Set function] - [General] - [Sub-display]

Caution If the code number or its parameter is changed during operation, the I/O status is changed, too.

Step 1 Press and hold the **SHIFT** key and press the **CODE SET** key.

Step 2 Enter the setpoint using the **numerical** keys. Press the **ENTER** key to store it and proceed to the next setpoint.

Step 3 Continue step 2 until entering all setpoints.

Step 4 Press the **ESC** key twice to return to previous mode.



7.2. The Menu of Code Edit

- The code can operate with the following menu of Code Edit.
 - Edit..... Edits full parameters of the code.
 - Search..... Finds a blank code.
 - Delete..... Deletes all data or a part of the data for the code.
 - Total..... Deletes total for a code.
 - Setpoint&Total.. Deletes setpoint and total for a code.
 - All Totals..... Deletes total for all codes.
 - All Codes..... Deletes all codes.
 - Copy..... Copies all parameters of a code to another code.
 - PT (Preset tare)..... Stores the current tare value to the preset tare of the specified code.

7.2.1. Edit

- This menu item can edit all of the parameters of the code.

- Step 1 Press and hold the **ENTER** key and press the **↵** key to enter the menu.
- Step 2 Select Code Edit using the **↵** key. Press the **ENTER** key.
- Step 3 Press the **ENTER** key to enter the menu Edit.
- Step 4 Enter a code number using the **numerical** keys. Press the **ENTER** key.
- Step 5 Edit each parameter of the code using **alphanumeric** keys.
Press the **ENTER** key to enter a new parameter and proceed to the next item.
- Step 6 Press the **ESC** key several times to return to the previous mode.

7.2.2. Search

- This menu item can find a blank code.

- Step 1 Press and hold the **ENTER** key and press the **↵** key to enter the menu.
- Step 2 Select Code Edit using the **↵** key. Press the **ENTER** key.
- Step 3 Select Search using the **↵** key. Press the **ENTER** key.
- Step 4 Press the **ENTER** key. Then the code number of a blank code is displayed.
- Step 5 Press the **ESC** key several times to return to previous mode.

7.2.3. Delete

- This menu item can delete all or a part of the data for the code.

Step 1 Press and hold the **ENTER** key and press the **↵** key to enter the menu.

Step 2 Select `Code Edit` using the **↵** key. Press the **ENTER** key.

Step 3 Select `Delete` using the **↵** key. Press the **ENTER** key.

Step 4 Select menu using the **↵** key. Press the **ENTER** key.

- `Total`..... Deletes total for a code.
- `Setpoint&Total` Deletes setpoint and total for a code.
- `All Totals` Deletes total for all codes.
- `All Codes` Deletes all codes.

In case that `Total` or `Setpoint&Total` is selected.

Step 5 Enter a code number using the **numerical** keys.

Press the **ENTER** key to delete it. Then `Deleted` is displayed.

In case that `All Totals` or `All Codes` is selected.

Step 6 Press the **ENTER** key to delete it. Then `Deleted` is displayed.

Step 7 Press the **ESC** key several times to return to previous mode.

7.2.4. Copy

- This menu item can copy all parameters of a code to another code.

Step 1 Press and hold the **ENTER** key and press the **↵** key to enter the menu.

Step 2 Select `Code Edit` using the **↵** key. Press the **ENTER** key.

Step 3 Select `Copy` using the **↵** key. Press the **ENTER** key.

Step 4 Enter the number of a source code using the **numerical** keys. Press the **ENTER** key.

Step 5 Enter the number of new code using the **numerical** keys. Press the **ENTER** key.
Then `Copied Code#` is displayed.

Step 6 Press the **ESC** key several times to return to previous mode.

7.2.5. Preset Tare

- This menu item can store the current tare value to preset tare (PT) of the specified code.
- Preset the Preset tare=0 choose [GENFF-12].

[GENF-12] Preset tare=0 choose

[1] Last tare If preset tare of the recalled code is zero, the previous tare value is used.

[2] Last tare If preset tare of the recalled code is zero, the tare value is cleared.

[Function] - [Set function] - [General] - [Basic] - [Preset tare=0 choose]

- Step 1 Press and hold the **ENTER** key and press the **↵** key to enter the menu.
- Step 2 Select Code Edit using the **↵** key. Press the **ENTER** key.
- Step 3 Select PT (preset tare) using the **↵** key. Press the **ENTER** key.
- Step 4 Enter the code number using the **numerical** keys.
- Step 5 Press the **ENTER** key. Then Copied tare value is displayed.
- Step 6 Press the **ESC** key several times to return to previous mode.



7.3. Recalling a Code

- The method to recall a code can be selected at Code recall method [59F-B 1].

Function and parameter	
59F-B 1 1	Code recall method Key/Serial I/F
59F-B 1 2	Code recall method Parallel I/F
59F-B 1 3	Code recall method External switch control

[Function] - [Set function] - [Sequence] - [Other]

Detail of Parameters

[59 F-B 1] Code recall method

[1] Key/Serial I/F

A code is recalled with key operation or input data of the interface.
The last data input has effect.

In case of using the **Key Operation**:

- Press the **CODE RECALL**. Enter a code number and press **ENTER** key.

In case of using the **Serial Interface**:

The code number can be entered by command mode.

- Built-in RS-485.
- RS-422/485 interface of OP-03.
- RS-232C interface of OP-04.

In Case of **Field Bus Interface**:

The code number is specified by PLC data.

[59 F-B 1] Code recall method

[2] Parallel I/F

A code is recalled with input data of the control I/O or parallel interface.
Use BCD code.

In Case of **Parallel Interface**:

The code number can be specified with BCD code. Example: encoder switch.

- Control I/O.
- Parallel interface of OP-05.

[59 F-B 1] Code recall method

[3] External switch control

Method of 1 or 2 can be selected at an input terminal specified to code number 48 in control I/O or OP-05. Terminal status is as follows:

Off: 1, Key/Serial I/F

On: 2, Parallel I/F. Code number of 2 is kept until next input.

Caution

- **When selecting Parallel I/F [2], do not specify the same function to the control I/O and OP-05.**

Example:

- When selecting External switch control [3], select External switch control [InF-01] [48] to terminal 1.
- When selecting External switch control [3], select External switch control [05F-01] [48] to terminal 1 of OP-05.
- When reducing the number of wires for the parallel interface, connect all common wires together and select the interface with the wires specified to External switch control [3].



8. Other Functions



8.1. Zero Tracking Function

- The function automatically traces the weighing deviation at the center of zero and keeps the zero display of the gross display.

Symbol

ZTR ▲	The sign is illuminated for one second when zero track function works.
----------	--

8.1.1. Static Zero Tracking Function

- The function is used during stop mode, manual mode, OK mode and simple mode.
- When the weighing value displays zero, if the weighing value is within zero tracking motion range after zero tracking time, the function resets the weighing value to zero.
- The function can work with a slow deviation and does not respond to quick deviations, such as a conveyor.

Concerning Parameters

[GEnF-7]	Zero tracking time 0.1s interval [0-99]
[GEnF-8]	Zero tracking motion 0.1d interval [0-99]

[Function] - [Set function] - [General]

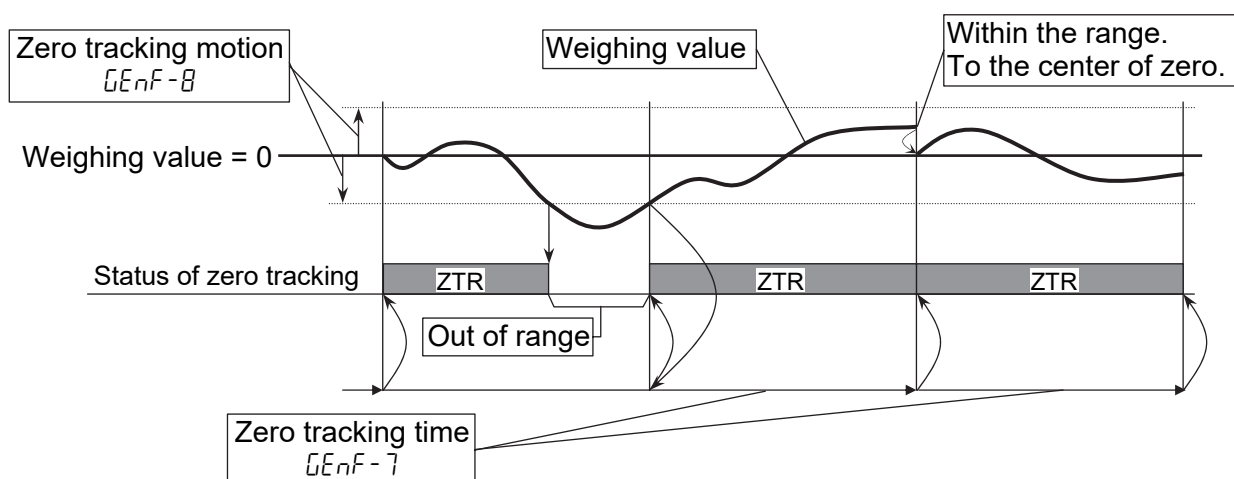

8.1.2. Dynamic Zero Tracking Function

- The function is used during automatic mode and conveyor stop mode, also when the conveyor is moving.
- The function can be used for gross display.
- To average the weighing value is performed at a constant time before loading the article.
- The function reduces one digit of an error in each zero tacking time, when the compensation value is more than ± 1.0 digit. The function does not zero the display value all at once.

Concerning Parameters

[59 F-71]	Zero tracking back timer 0.1s interval [0-50]
[59 F-72]	Zero tracking average timer 0.1s interval [0-50]
[59 F-73]	Zero tracking MIN interval 0.1d interval [0-999]
[59 F-74]	Zero tracking amplitude 0.1d interval [0-999]

[Function] - [Set function] - [Sequence] - [Zero track]

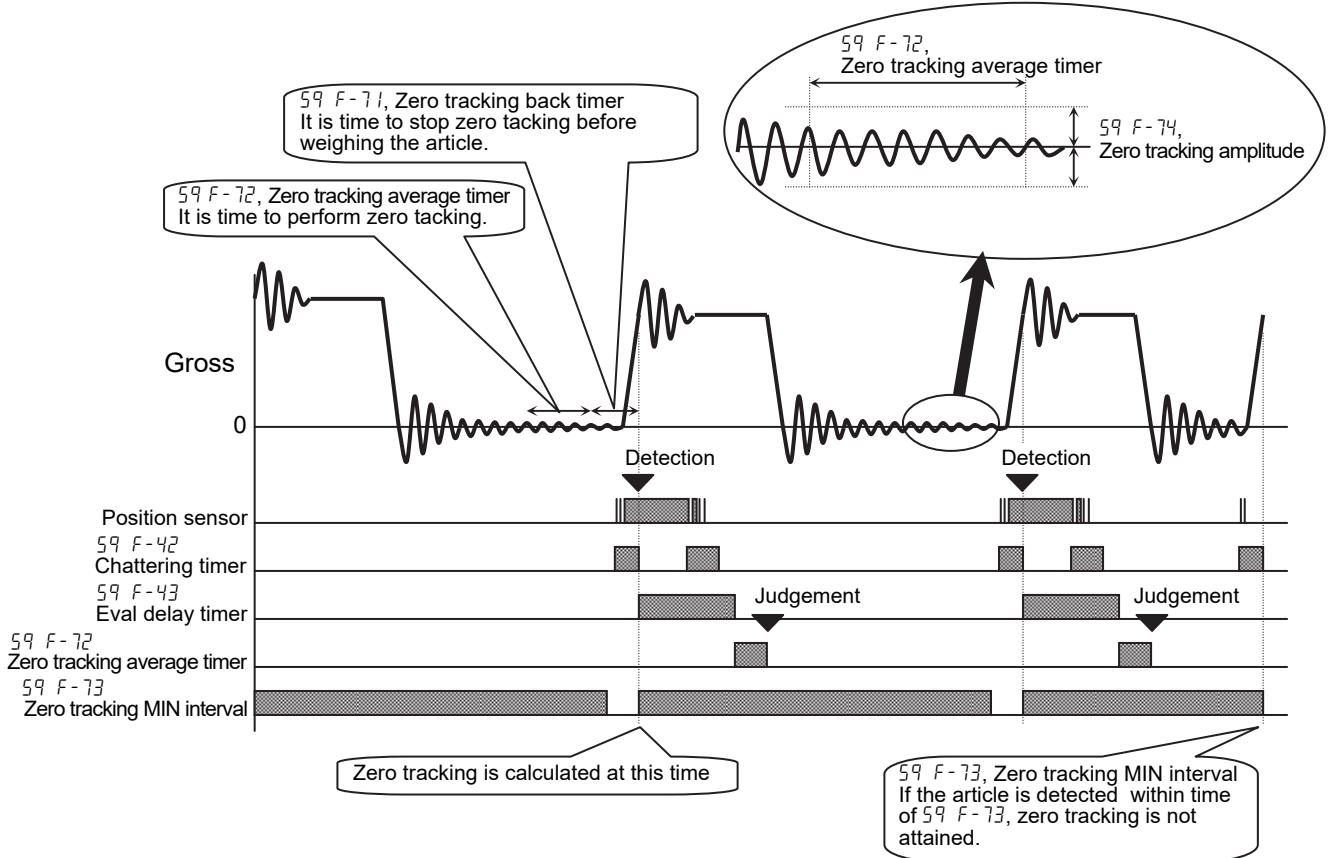



8.2. Judgement and Selector Action

- The function is used to weigh and classify (judge or check) the article put on the weighing conveyor in automatic mode [59 F-1] [1] and conveyor stop mode [59 F-1] [2].
- The actions of the selectors can be selected at Selection of comparison [59 F-2] and Selector 1 condition [59 F-22] to Selector 1 condition [59 F-22]. Example: "If it includes foreign matter, push it using selector 1.". [59 F-22] [000000 100].
- The action of the conveyor can be selected at Conveyor stop condition [59 F-2 1]. Example: "If it is OK, pause conveyor and pick up it by hand". [59 F-2 1] [00 1000000].
- There are five kinds of Selection comparison [59 F-2].
- A maximum of six selectors can be selected.

Function and parameter		Description	
59F-2 1	Selection of comparison 3 levels with target	Lo output OK output Hi output	Net < (target - Lo) (target - Lo) ≤ Net ≤ (target + Hi) (target + Hi) < Net
59F-2 2	Selection of comparison 3 levels without target	Lo output OK output Hi output	Net < Lo Lo ≤ Net ≤ Hi Hi < Net
59F-2 3	Selection of comparison 5 levels with target	LoLo output Lo output OK output Hi output HiHi output	Net < (target - LoLo) (target - LoLo) ≤ Net < (target - Lo) ≤ Net ≤ (target + Hi) (target + Hi) < Net ≤ (target + HiHi) (target + HiHi) < Net
59F-2 4	Selection of comparison 5 levels without target	LoLo output Lo output OK output Hi output HiHi output	Net < LoLo LoLo ≤ Net < Lo Lo ≤ Net ≤ Hi Hi < Net ≤ HiHi HiHi < Net

59F-22	Selector 1 condition	1: push, 0: not pushed Example: 11011111
59F-23	Selector 2 condition	
59F-24	Selector 3 condition	
59F-25	Selector 4 condition	
59F-26	Selector 5 condition	
59F-27	Selector 6 condition	

Each bits means as follows:

- LoLo,
- Lo,
- OK,
- Hi,
- HiHi,
- Foreign material detection,
- Duplication,
- Crush



8.3. Loss-in-weight

- The function is used to weigh the decrease of the articles in a positive value.
Loss-in-weight [59 F-3] [1]
- The tare value can be set from the following value.
 - Weighing tare and tare key operation
 - Preset value of the code
 - The tare value received by serial interface

Weighing Procedure

Step 1 Make zero display using the tare function to store all articles and tare.

Step 2 When weighing articles on the weighing conveyor, the decrease in the weight is displayed as a positive value.



8.4. Motion Compensation

- The function is used at automatic mode [59 F-1] [1] that continuously moves the weighing conveyor.
- The function stores the compensation coefficient.
Move correction coefficient [59 F-12]
- The function calculates the correction weight by the following formula.
Compensation value = (compensation coefficient) x (weighing value in motion)
- When the compensation coefficient is not 1.00000 in the automatic mode, indicator D.COMP ▲ is displayed and the value is compensated.



8.5. Detection Method

- There are four detection methods for the article.
 - Detecting the front of the article with the position sensor.
 - Detecting the end of the article with the position sensor.
 - Detecting gross above the zero band.
 - Detecting gross within the zero band.
- Place the position sensor at the front of the weighing conveyor.
The position sensor is assumed to be a photoelectric sensor or laser sensor
- Use the Chattering timer [59 F-42] to prevent an error.
Use the Eval delay timer [59 F-43], when the article is detected.

8.5.1. Detecting Front with Position Sensor

- Select Top edge of the Detector [59 F-29] [1].
- Procedure:
 - 1 The front of the article crosses to the position sensor.
 - 2 When the sensor output changes from OFF to ON, Chattering timer [59 F-42] starts.
 - 3 When Chattering timer [59 F-42] is up, Eval delay timer [59 F-43] starts.
 - 4 When Eval delay timer [59 F-43] is up, the detection has effect.

Memo

- If the article is packed in a clear bag, use a long delay time to prevent an error with Chattering timer [59 F-42].

8.5.2. Detecting End with Position Sensor

- Select Tail edge of the Detector [59 F-29] [2].
- The tolerance of Eval delay timer [59 F-43] is wide, because the timer starts after the article is put on the weighing conveyor that moves in various velocities.
- Procedure:
 - 1 The end of the article crosses to the position sensor.
 - 2 The sensor output changes from ON to OFF.
 - 3 Eval delay timer [59 F-43] starts.
 - 4 When Eval delay timer [59 F-43] is up, the detection has effect.

8.5.3. Detecting Gross Value above Zero Band

- Select Over zero band of Gross of the Detector [59 F-29] [3].
- Procedure:
 - 1 The article is moved on the weighing conveyor.
 - 2 When the gross is above the zero band, the detection has effect.

Caution

- **This method can not be used for high velocity and intolerable vibration of the weighing conveyor, because it can not detect duplication of the articles or the position of the article.**

8.5.4. Detecting Gross Value within Zero Band

- Select Zero band of Gross of the Detector [59 F-29] [4].
- Procedure:
 - 1 When the gross value is within the zero band, the detection has effect.



8.6. Check to Forward the Article

- The function is used to forward the compared article from the weighing conveyor.
- Select OK mode of the Weighing mode [59 F-1] [3] to use the check.
- Select the mode at Detector [59 F-29].
- Procedure for this mode:
 - 1 When the comparison has effect, the article is forwarded from the weighing conveyor and Conveyor stop delay timer [59 F-59] starts.
 - 2 The conveyor moves, until Conveyor stop delay timer [59 F-59] is up.



8.7. Duplication of the Articles

- When the next article is placed on the weighing conveyor before the last article is forwarded from the conveyor, an error message and `SO.ERR2` is displayed and duplication is output.
- The total of the weighing value classifies the duplication in the total data.

Caution

- **Trim the Chattering timer [59 F-29] and placement of the position sensor to avoid duplication.**

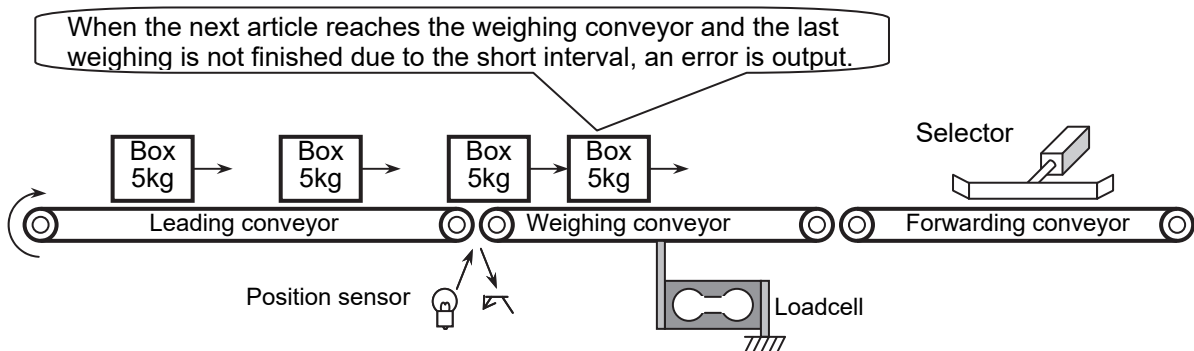

8.8. Crush of the Articles

- When articles move between the weighing conveyor and the selector, an error message and `SO.ERR6` is displayed and crush is output.
- At maximum, the AD-4404 can control ten articles that are waiting for the selector.
- The total of the weighing value is classified as crushed in the total data.

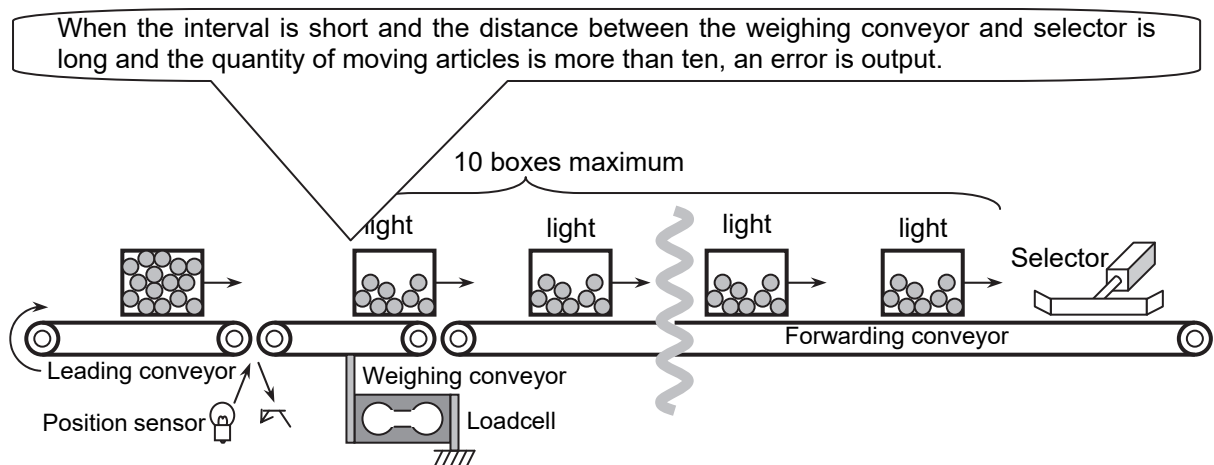



8.9. BUSY Output

- The BUSY output is turned on at loading the article on the weighing conveyor. The BUSY output is turned off until it classifies with the selector. And the AD-4404 can control up to ten articles continuously.
- If an article is loaded on the weighing conveyor after the busy state is off, it can avoid duplication and crush of the articles. It is effective to have a long weighing interval.
- The BUSY signal is output on the following condition.
- The BUSY signal is output, when the following timer is counting.
 - Eval delay timer [59 F-43]
 - Average timer [59 F-44]
 - Selection out 1 delay timer [59 F-46]
 - Selection out 2 delay timer [59 F-47]
 - Selection out 3 delay timer [59 F-48]
 - Selection out 4 delay timer [59 F-49]
 - Selection out 5 delay timer [59 F-50]
 - Selection out 6 delay timer [59 F-51]
 - Select output 1 timer [59 F-52]
 - Select output 2 timer [59 F-53]
 - Select output 3 timer [59 F-54]
 - Select output 4 timer [59 F-55]
 - Select output 5 timer [59 F-56]
 - Select output 6 timer [59 F-57]



8.10. Stop Input during BUSY

- Procedure for a stop input during operation:
 - 1 When a stop input is entered while BUSY is turned on, the status changes to pause.
 - 2 All timers are held. Status indicators blink.
- Procedure to continue the current weighing:
 - 1 When an operation input is entered during pause, all timers restart counting.
- Procedure for a stop input during pause:
 - 1 When a stop input is entered during pause, status changes to stop mode.
 - 2 All timers are reset. Status indicators are turned off.

Refer to " 4.2.2. Status of Weighing Mode".



8.11. Output for Foreign Matter Detection

- Procedure:
 - 1 When the sensor detects foreign matter and sends the signal to the AD-4404, the foreign matter detection is output until the AD-4404 judges the signal and totals it.
- The output can be used to control peripherals.

This signal means that there is foreign matter between the sensor and the weighing conveyor.
- Procedure for a stop input during the detection:
 - 1 When a stop input is entered during the detection, the status changes to pause.
 - 2 All timers are held. Status indicators blink.
- Refer to " 6.3. Foreign Matter Detection".



8.12. Evaluation Output

- There are three types of output for judgement.
 - Comparison output.
 - Output to selectors.
 - Buzzer output.

8.12.1. Comparison Output

- The comparison output is used to input signals to a PLC and to a peripheral indicator.

It is output, when averaging weight and judging it.
- Kind of output: LoLo, Lo, OK, Hi, HiHi, Foreign matter, Duplication, Crush, NG.

Relations: Conveyor stop condition [59 F-2 I], Sub-display, I/O output,

8.12.2. Output to Selectors

- The output is used to control the selector using the timer.
- A maximum of six selectors can be connected to the AD-4404.
- Output according to conditions and timers.
 - Selector 1 condition [59 F-22]
 - Selector 2 condition [59 F-23]
 - Selector 3 condition [59 F-24]
 - Selector 4 condition [59 F-25]
 - Selector 5 condition [59 F-26]
 - Selector 6 condition [59 F-27]
 - Selector 1 condition [59 F-22]
- When the interval is short and the distance between the weighing conveyor and selector is long, a maximum of ten judgements will be stored into memory for each selector.

Therefore each selector can be stored ten suits of judgement, the output delay timer and output timer. At maximum, sixty suits of data can be stored in the six selectors.

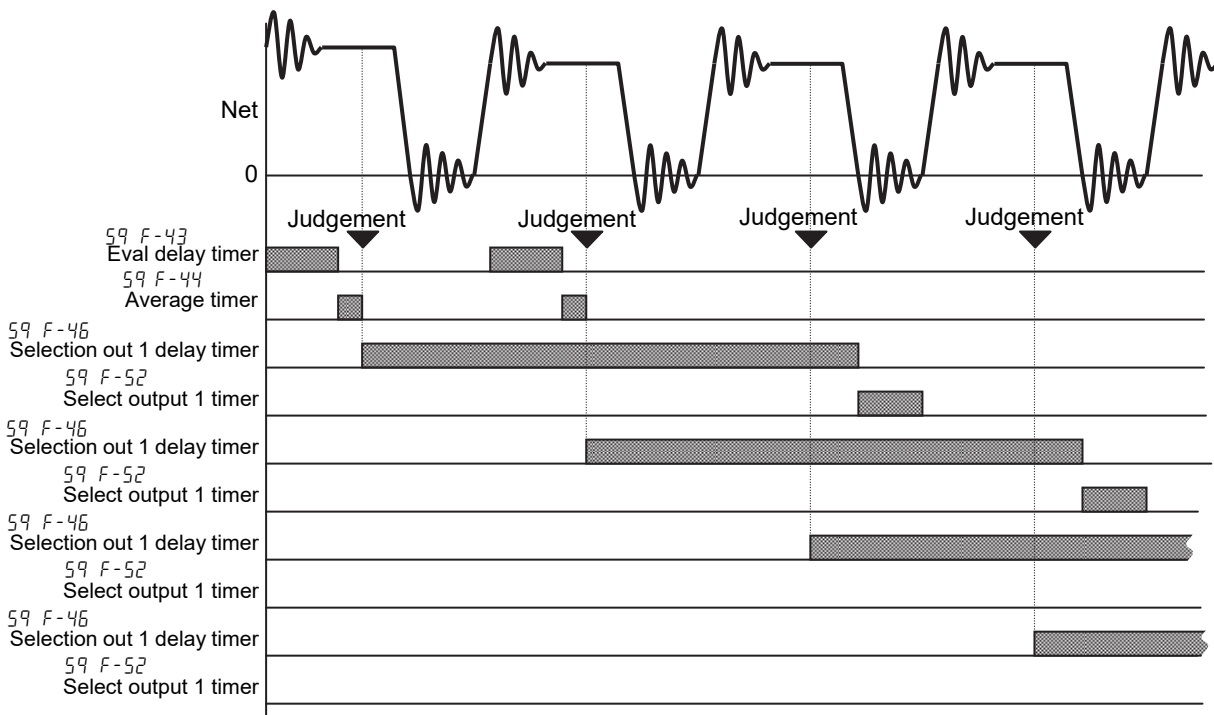



8.13. Buzzer Output

- The judgement of the buzzer output is the same as the judgement of comparison output. The buzzer can be select six rhythms of sound. Each buzzer condition stores conditions to sound it for LoLo, Lo, OK, Hi, HiHi, foreign matter, duplication, crush and counter limit.

Buzzer condition 1	[59 F-5]	Continuous
Buzzer condition 2	[59 F-6]	0.5 Hz
Buzzer condition 3	[59 F-7]	1 Hz
Buzzer condition 4	[59 F-8]	2 Hz
Buzzer condition 5	[59 F-9]	4 Hz
Buzzer condition 6	[59 F-10]	8 Hz

- The buzzer sounds for preset time of Buzzer ON timer [59 F-41].
- When the **BUZZER STOP** key is pressed, the sound can be stopped.

Caution

- **The buzzer needs a power supply.**

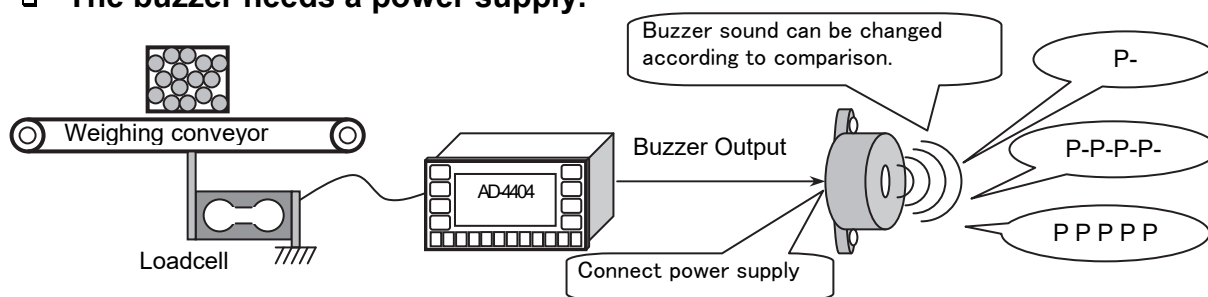

8.14. Total Function

- The judgement can be classified and accumulated for totals of each code.

Type	Description
Total count	Total number of all data
NG count	Count without OK data
OK count	Count of OK data
Hi count	Count of Hi data
Lo count	Count of Lo data
HiHi count	Count of HiHi data
LoLo count	Count of LoLo data
Foreign matter count	Count of foreign matter
Duplication count	Count of duplication. A detection assumes as one count.
Crush count	Count of crush. A detection assumes as one count.
Maximum	Maximum value of adequate data
Minimum	Minimum value of adequate data
Average	Average of adequate data
Standard deviation	Standard deviation of adequate data σ_{n-1}
Population standard deviation	Population standard deviation of adequate data σ_n
Total weight	Total weight of adequate data



8.15. Safety Check Function

- The safety check function stops the check weighing sequence, when an error occurs.
- The input of a safety check function can be assigned to a terminal of the control I/O or OP-05. A maximum of eight safety check functions can be assigned to each terminal.
- When turning off a terminal assigned to safety check, an error message and SQ. ERR 1 is displayed and the check weighing sequence paused.

Caution

- **Do not assign the same safety check function to terminals of the control I/O and OP-05.**

Concerning Parameters

[59 F-83] Safety check
[00000000]

Specify use of each safety check function.

0: not used, 1: use

[Function] - [Set function] - [Sequence] - [Other]

[In F-xx] In xx (Axx)

Input terminal of the control I/O.
xx is terminal number (01 to 11).

[28]	Safety check 1	Safety check 1
[29]	Safety check 2	Safety check 2
[30]	Safety check 3	Safety check 3
[31]	Safety check 4	Safety check 4
[32]	Safety check 5	Safety check 5
[33]	Safety check 6	Safety check 6
[34]	Safety check 7	Safety check 7
[35]	Safety check 8	Safety check 8

[Function] - [Set function] - [control I/O] - [Input]

[OP F-xx] In xx (Axx)

Input terminal of OP-05.
xx is terminal number (01 to 16).

[28]	Safety check 1	Safety check 1
[29]	Safety check 2	Safety check 2
[30]	Safety check 3	Safety check 3
[31]	Safety check 4	Safety check 4
[32]	Safety check 5	Safety check 5
[33]	Safety check 6	Safety check 6
[34]	Safety check 7	Safety check 7
[35]	Safety check 8	Safety check 8

[Function] - [Set function] - [Option] - [OP-05 parallel I/O]- [Input]

Example

- When the beam of light is interrupted and the photo sensor turns off, the sequence is stopped.

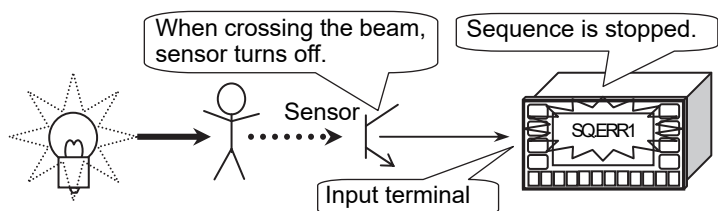



8.16. Zero Operation

- The zero operation zeroes the display and changes to the gross display.
- The operation can be performed from the front panel key or the input terminal of the control I/O.
- The adjustable range is based on the zero calibration and Zero range [GFNF- 6]. The range is displayed in the unit of percentage of the weighing capacity.
- If the operation can not be achieved, an error message and ZR.ERR is displayed.
- The re-zero data is maintained in memory even without power.

Key Operation

Pressing and holding the **SHIFT** key, press the **ZERO** key.

Operation from Control I/O

- [In F-xx] In xx (Axx) The input terminal of the control I/O.
- [0 1] Zero When it turns on, zero of gross is displayed.
xx is terminal number (01 to 11).
[Function] - [Set function] - [control I/O] - [Input]

Concerning Parameters

- [GFNF- 1] Zero range
Range is within 30% of the weighing capacity.
[Function] - [Set function] - [General] - [Weight]
- [GFNF-9] Tare & zero unstable UGT
The prohibition of the re-zero operation in the unstable condition.
[Function] - [Set function] - [General] - [Weight]
- [GFNF- 13] Clear mode at power ON
Specify power-on status.
[Function] - [Set function] - [General] - [Weight]



8.17. Tare Operation

- The relation of the display is as follows:
Net = Gross - Tare

Key Operation

Press the **TARE** key.

Operation from Control I/O

- [In F-xx] In xx (Axx) The input terminal of the control I/O.
- [03] Tare When it turns on, zero of net is displayed.
xx is terminal number (01 to 11).
[Function] - [Set function] - [control I/O] - [Input]

Concerning Parameters

- [GE_nF-9] Tare & zero unstable UGT
The prohibition of the re-zero operation in the unstable condition.
[Function] - [Set function] - [General] - [Weight]
- [GE_nF-10] Tare at (-)Gross weight
The prohibition of the tare operation during negative weighing.
[Function] - [Set function] - [General] - [Weight]
- [GE_nF-13] Clear mode at Power ON
Specify power-on status.
[Function] - [Set function] - [General] - [Weight]

8.17.1. Tare Clear Operation

- The function displays a gross value that is not compensated by the tare operation or the zero operation.

Key Operation

Step 1 Turn off the display.

Step 2 Pressing and holding the **TARE** key, press the **ON** key.

Operation from Control I/O

- [In F-xx] In xx (Axx) The input terminal of the control I/O.
- [04] Tare clear When it turns on, the original gross is displayed.
xx is terminal number (01 to 11).
[Function] - [Set function] - [control I/O] - [Input]



8.18.Preset Tare

- A preset tare (PT) can be stored in each code. The preset tare can be used, when the tare value is specified in advance.
The relation of the display is as follows
Net = Gross - PT

Key Operation

Store a preset value to PT of the code. Refer to "7 . Code".

Concerning Parameters

[GEnF-11] Preset tare

The permission of preset tare function

[Function] - [Set function] - [General] - [Weight]

[GEnF-12] Preset tare=0 choose

Update of preset tare

[Function] - [Set function] - [General] - [Weight]

[othF-4] Tare header

Classifying normal tare and preset tare of the serial data.

[Function] - [Set function] - [General] - [Other]



8.19.Customizing F1 and F2 key

- Pressing this key, the key works as the **F1** key.
Pressing and holding the **SHIFT** key and press this key, the key works as the **F2** key.
Preset the function of the F1 and F2 key at item *othEF-2* and *othEF-3* in the function list.

Function	Parameter and Description
[othF-2] F1key function	0 No function
	1 Print key
	2 (Do not use)
	3 (Do not use)
	4 Tare clear key
and	5 Gross / Net key
[othF-3] F2key function	6 The key to cancel last judgement
	7 The key to finish judgement and target count
	8 Error reset key
	9 The key to clear total data of all codes
	10 Total print key

[Function] - [Set function] - [General] - [Weight]



8.20. Customizing Sub Display

- Use the default sub-display pattern, if you want to reset it. The default uses 3 levels with a target.
- Select a format of the sub display.
 - Use the default display of the sub display at `Basic display [Sub F-1] [0]`.
 - Store the new design of the sub display at `Custom format [Sub F-1] [1]`.
[Function] - [Function setting] - [General] - [Sub-display]

Row and Column Address

	0	1	2	3	4	5	6	7	8	9	10	11	12	13	14	15	16	17	18	19	20	21	22	23	24	25	26	
0																												
1																												
2																												
3																												

Row 0 and 2 are dot matrix display for alphanumerical character.
Row 1 and 3 are 7-segment display for numerical character.

Display to Store Items

Item index number to be displayed. A maximum of 32 items of name and number can be set.
At **odd**: Input the name of the selected item using alphanumeric characters.
At **even**: Input the number concerning the item.

Information for key operation

Name of the item

Items to append to the sub-display

Resize the item selected.

The screenshot shows a sub-display menu with the following text: "Sub F 1", "Sub F1-3 [name]", "Object-01", and a table with columns "Row/Col/Dig" and values "19 0 16 5".

Items to append to the sub-display

No.	Item Name and Description	Row size	Column size	Figures
0	Not displayed	0 to 3	0 to 26	1 to 12
1	Code name			
2	Target			
3	Hi			
4	Lo			
5	HiHi			
6	LoLo			
7	Zero band			
8	Count of target data			
9	Tare			
10	Target Count			
11	Count of total data			
12	Count of OK data			
13	Count of NG (without OK data)			
14	Count of Hi data			
15	Count of Lo data			
16	Count of HiHi data			
17	Count of LoLo data			
18	Count of foreign matter			
19	Count of duplication			
20	Count of crush			
21	Maximum value of adequate data			
22	Minimum value of adequate data			
23	Average of adequate data			
24	Standard deviation of adequate data σ_{n-1}			
25	Population standard deviation of adequate data σ_n			
26	Total weight of adequate data			
27	Gross			
28	Net			
29	Graph			

Example of Basic Display Layout

- Store items according to the arrow in order. The order is from upper-left side item to the right item and lower-left item to the right in order.

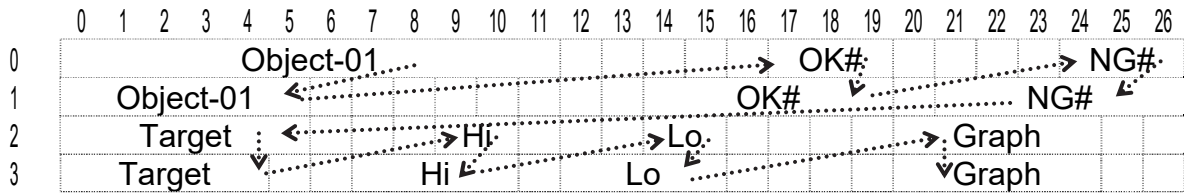

Object-01	OK#	NG#
Code 0	20	1
Target	Hi	Lo
10000	1500	1000
	L	H

Parameter List of Example

No.	Item	Code	Row	Column	Digit
Sub F1- 1	Object-01	Name	1	0	12
Sub F1- 2	Object-01	Number	1	0	6
Sub F1- 3	OK#	Name	12	17	3
Sub F1- 4	OK#	Number	12	14	6
Sub F1- 5	NG#	Name	13	24	3
Sub F1- 6	NG#	Number	13	21	6
Sub F1- 7	Target	Name	2	0	6
Sub F1- 8	Target	Number	2	1	5
Sub F1- 9	Hi	Name	3	9	2
Sub F1- 10	Hi	Number	3	7	4
Sub F1- 11	Lo	Name	4	14	2
Sub F1- 12	Lo	Number	4	12	4
Sub F1- 13	Graph	Name	29	20	5
Sub F1- 14	Graph	Number	29	20	5



8.21 .Graph Display

- The graph indicates the current weighing value in the sub-display.



HiHi indicator.



Hi indicator.



OK indicator. Level is displayed between Lo and Hi.



Lo indicator.



LoLo indicator..

- The indicator is controlled by Selection comparison [59 F-2].

Function and parameter		Description	
59F-2 1	Selection of comparison 3 levels with target	Lo OK Hi	$\begin{aligned} & \text{Net} < (\text{target} - \text{Lo}) \\ & (\text{target} - \text{Lo}) \leq \text{Net} \leq (\text{target} + \text{Hi}) \\ & (\text{target} + \text{Hi}) < \text{Net} \end{aligned}$
59F-2 2	Selection of comparison 3 levels without target	Lo OK Hi	$\begin{aligned} & \text{Net} < \text{Lo} \\ & \text{Lo} \leq \text{Net} \leq \text{Hi} \\ & \text{Hi} < \text{Net} \end{aligned}$
59F-2 3	Selection of comparison 5 levels with target	LoLo Lo OK Hi HiHi	$\begin{aligned} & \text{Net} < (\text{target} - \text{LoLo}) \\ & (\text{target} - \text{LoLo}) \leq \text{Net} < (\text{target} - \text{Lo}) \\ & (\text{target} - \text{Lo}) \leq \text{Net} \leq (\text{target} + \text{Hi}) \\ & (\text{target} + \text{Hi}) < \text{Net} \leq (\text{target} + \text{HiHi}) \\ & (\text{target} + \text{HiHi}) < \text{Net} \end{aligned}$
59F-2 4	Selection of comparison 5 levels without target	LoLo Lo OK Hi HiHi	$\begin{aligned} & \text{Net} < \text{LoLo} \\ & \text{LoLo} \leq \text{Net} < \text{Lo} \\ & \text{Lo} \leq \text{Net} \leq \text{Hi} \\ & \text{Hi} < \text{Net} \leq \text{HiHi} \\ & \text{HiHi} < \text{Net} \end{aligned}$

- The graph can be displayed in the sub-display, when No. 29 graph is specified at Custom format [Sub F-1] [1].
Example: Refer to "Example of Basic Display Layout" on the previous page.



8.22. Canceling Last Judgement

- The function can be operated with the terminal for the control I/O, when the terminal is specified to `Cancel the last result [12]`.
- The last judgement is canceled, when the terminal is active after the judgement.



8.23. Clearing the Total

Key Operation

- The total of the current code can be cleared with the following operation.

Step 1 Press and hold the **SHIFT** key and press the **CLEAR TOTAL** key.

Code Edit Mode

- The following totals can be cleared in menu `Code edit`. Refer to "7.2.3. Delete" for operation.
 - `Total.....` Deletes total for a code.
 - `Setpoint&Total.....` Deletes setpoint and total for a code.
 - `All Totals.....` Deletes total for all codes.
 - `All Codes.....` Deletes all codes.

Control I/O

- There are two methods to clear the totals. These functions can be operated with the terminals of the control I/O, when the terminals are specified by the following functions.
 - `Clear totals of code [24]`.
 - `Clear all code totals [25]`.

Parallel I/O of OP-05

- There are two methods to clear the totals. These functions can be operated with the terminals of the parallel I/O, when the terminals are specified by the following functions.
 - `Clear totals of code [24]`.
 - `Clear all code totals [25]`.

Command of Serial Interface

- The totals can be cleared with the following command.
 - `CDTLxxxx` Total of a specified code is cleared. xxxx is the code number
 - `CETL` All total is cleared.



8.24. Error Message and Alarm

- When the indicator detects an error in the weighing system, an error message is displayed, alarm sounds and the error status is output to the control I/O.
- Press the **ESC** key to clear the message.
If there is another error after pressing the **ESC** key to clear first message, the second error message is displayed.
- The error number can be output from the BCD output of OP-01 or the serial interface.
- Clear the error with the terminal of the control I/O that is specified to Error reset [44].
If there are multiple errors, the prior error is cleared first.

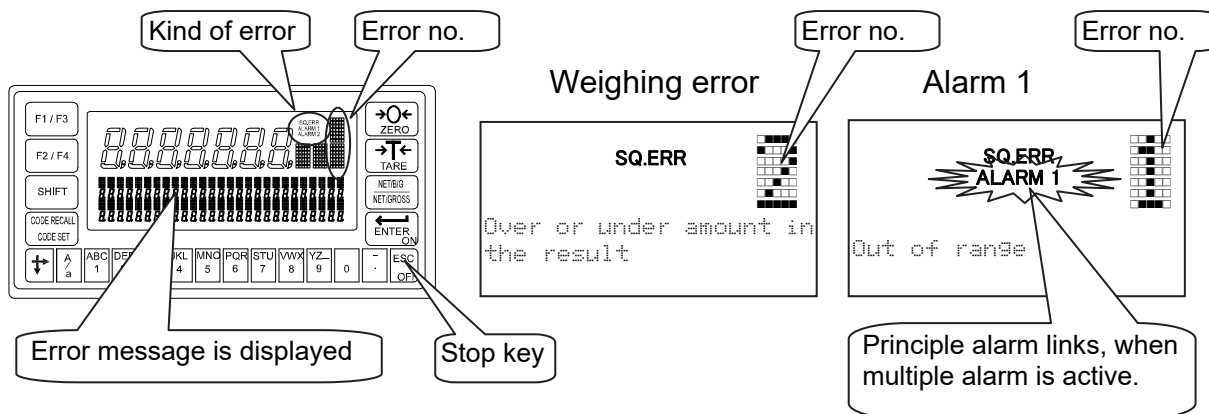

Kind of Alarm and Error

There is the following priority.

Weighing sequence error < Zero error < Alarm 1 < Alarm 2
 SQ.ERR ZR.ERR ALARM 1 ALARM 2

Kind	No.	Description
Check weighing sequence error SQ.ERR	When the weighing can not continue, a message is displayed and the sequence is stopped. Cope with cause and restart the weighing.	
	0	The sequence pauses. Cope with cause and restart the sequence.
	1	Safety check can not be completed. Check the safety.
	2	Duplication has occurred. Increase the interval between the articles.
	3	There is a conflict in the setpoints Check setpoint
	4	There is foreign matter on the weighing conveyor. Remove the foreign matter to start the sequence.
	5	The article includes foreign matter. Check it.
6	A crush error has occurred due to a fast conveyor. Increase the interval between the articles.	

Kind	No.	Description
Zero error ZR.ERR	When the displayed value can not be set to zero with re-zero or tare, this message is displayed.	
	0	Display can not be zeroed by zero compensation.
	1	Display can not be zeroed by tare operation.
	2	Unstable display.
Alarm 1 ALARM 1	When the weighing value is out of range and emergency stop is performed, this symbol is displayed.	
	1	The weighing value is out of range.
	9	Emergency stop has been performed.
Alarm 2 ALARM 2	It can not weigh. Check the weighing system. Example: loadcell cable, connectors.	
	1	A/D converter is positive over count. Check the loadcell cable.
	2	A/D converter is negative over count. Check the loadcell cable.
	4	RAM error. Check the backup battery



8.25. Graphic Status Indicator

- The indicator can display the weighing status and the result on the graphic status indicator.

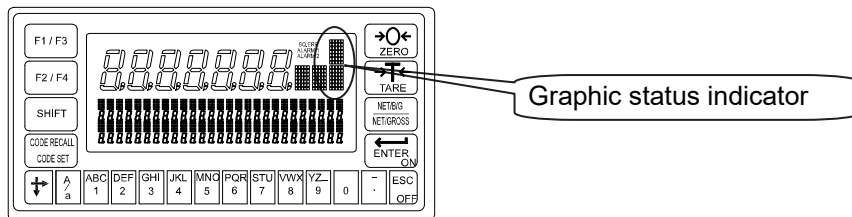

Upper Side	Description	
	LoLo	The current result is LoLo.
	Lo	The current result is Lo.
	OK	The current result is OK.
	Hi	The current result is Hi
	HiHi	The current result is HiHi
	Foreign matter	It is displayed, when detecting foreign matter.
		Other weighing errors. Duplication, Crush or etc.

Lower Side	Description	
		The conveyor is in motion.
	Loading symbol	It is displayed until the evaluation delay timer 43 is up after detecting the article on the weighing conveyor. It is not displayed in OK mode [59 F-0 1] [3] or manual mode [59 F-0 1] [4].
	Averaging symbol	It is in the process of evaluation.
	Forwarding symbol	It is displayed until the weighing value is within the zero band after forwarding the article. It is not displayed in OK mode [59 F-0 1] [3] or manual mode [59 F-0 1] [4].
	Counter finish	The counter of the article has reached the preset limitation.
	Stop	It has no symbol.

Concerning Parameters

[SubF-2] Activity indicator

[0] Not used.

[1] Use.

[Function] - [Set function] - [General] - [Sub display]



8.26. Memory Backup

- The indicator has two kinds of memory.
 - Flash memory This memory is used to store important data without power supplied that the occurrence of re-writing them is seldom.
Life of re-writing them is approximately 100,000 times or more.
Data example: Calibration, Function, Code

 - Backup RAM This memory is used to store temporary data that the occurrence of re-writing them is often.
Life of the battery is approximately 10 years at 25 °C, normal use
Data example: Tare, Total, Re-zero data

- The code can be stored in flash memory or backup RAM.

Concerning Parameters

[p~~th~~F-8] Save data

[1] Save in RAM

[2] Save in flash memory When re-writing code, the sequence is stopped.

[Function] - [Set function] - [General] - [Other]



9. Interface



9.1. Control I/O Function

- The control I/O is the interface to communicate system status and sequence commands between the indicator and peripherals.
Input terminals..... 11 lines that can be selected by the function
Output terminals 11 lines that can be selected by the function
The output terminals use open collector transistors
- Preset the functions to these terminals. Refer to "11. Function List".
[Function] - [Set function] - [Control I/O]

Caution

- Do not assign the same function to multiple terminals of the control I/O and OP-05.

9.1.1. Interface Circuit

Input terminal

	Maximum	typ.
Input open voltage	14V DC	10 V DC
Input drive current	5 mA	3 mA
Saturation tolerance voltage	2 V DC	

Output terminal

	Maximum
Output voltage	40 V DC
Output current	50 mA
Saturation tolerance voltage	1.5 V at 50 mA

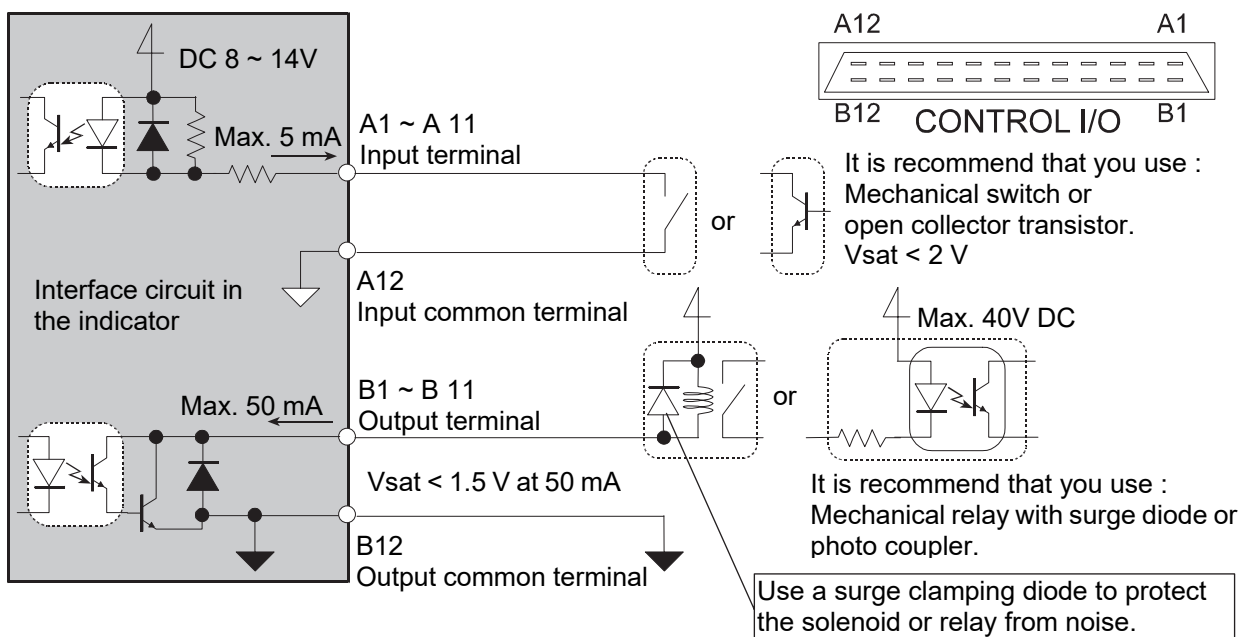

9.1.2. Timing Chart

Caution

- Keep the delay time to avoid abnormal-operation and noise.
- Keep the input signal more than 50 ms to avoid noise and chattering.
- Acknowledge terminal is active for five seconds, when the indicator receives a signal.

Example

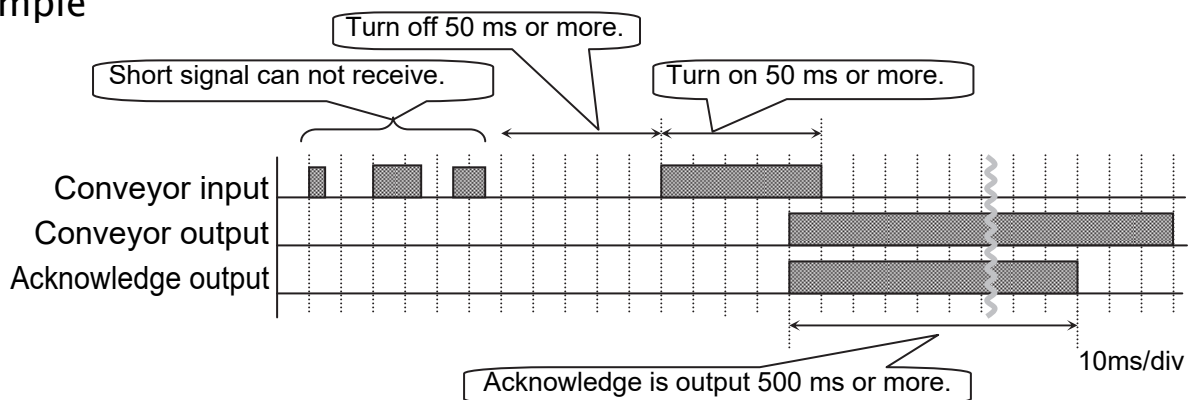



9.2. Built-in RS-485 Interface

- The RS-485 interface can use commands to control the indicator. The interface can read weighing data or parameters and store parameters in the indicator.
- The interface can connect 32 units maximum and a personal computer using a communication cable.
- Each unit is specified by an address appended to the command.

Specifications

Transmission system.....	EIA RS-485, Asynchronous, bi-directional, half-duplex
Data length	7 bits or 8 bits
Start bit	1 bit
Parity bit	Odd, Even, not used
Stop bits	1 bit, 2 bits
Baud rate.....	600 bps, 1200 bps, 2400 bps, 4800 bps, 9600 bps, 19200 bps, (38400 bps for jet stream mode only)
Line	2 wires (2-balanced wires)
Connection	Max. 32 units
Character code	ASCII code
Terminator.....	CR, CR LF

Instructions for Use

- When using a terminator, connect it to the SDA and SDB terminals using the accessory resistor.
- If there is no signal ground at the host computer, it is not necessary to use the SG terminal.
- If a shielded cable is used, connect the FG terminal to the shield line.
- When connecting to the RS-232C, use a converter of an RS-232C/ RS-485 converter available on a market.
- Use a multiple drop connection for command mode.
Do not use a multi-drop connection in stream mode or jet stream mode.

9.2.1. Settings of Parameters for RS-485

Refer to the "11. Parameter List" of the function list.

[Function] - [Set function] - [Serial] - [RS-485] - [*r*5 *F* - 1] to [*r*5 *F* - 13]

9.2.2. Connection

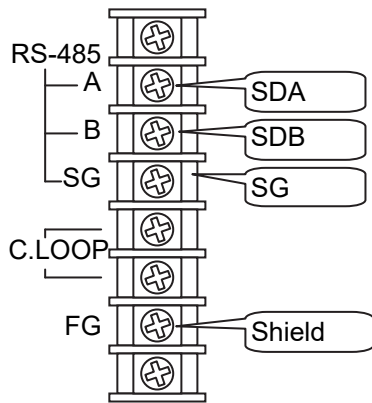

Terminals

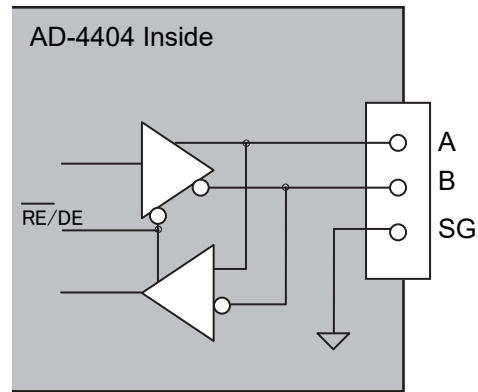

Interface Circuit

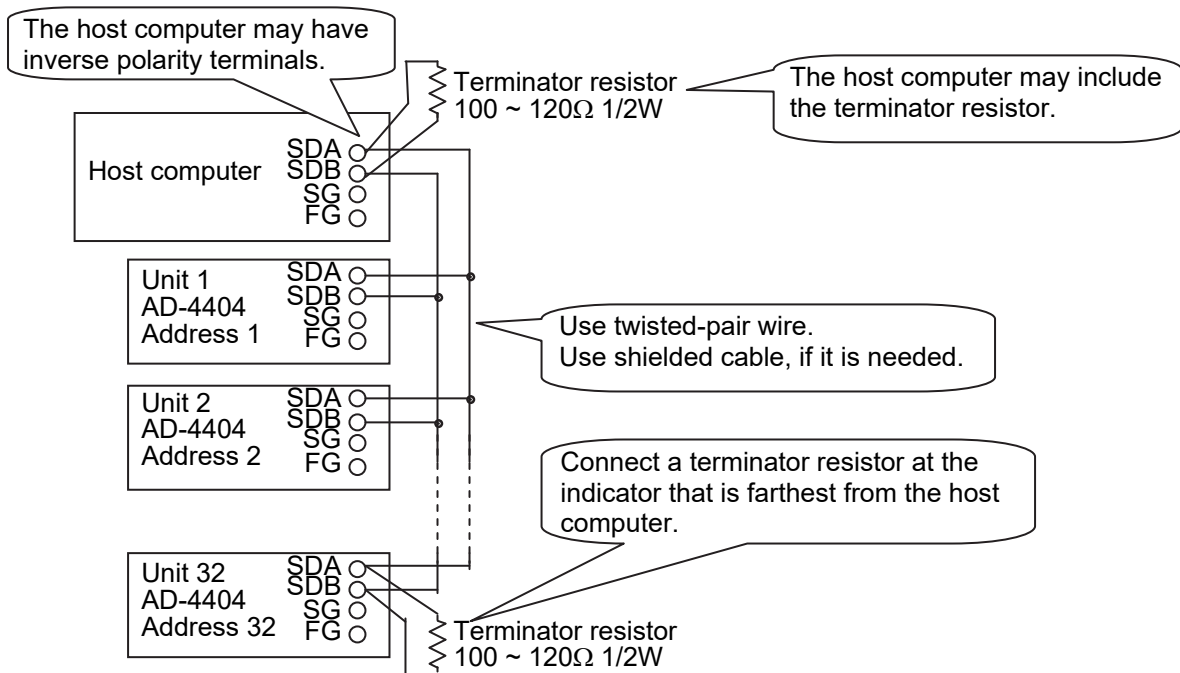

Multiplex Drop Connection for Command Mode

9.2.3. Timing Chart

- Keep the delay time above 0.5 ms between the last response and the next command.
- Set response time (tr). $[r5 F- 9] < tr < [r5 F- 9] + 50 \text{ ms}$
- Use a long delay time, when there is noise.
- Hi-Z: Hi impedance

Caution

- **If next command is transmitted from computer within 0.5 ms from the end of last command, an interface error may occur.**

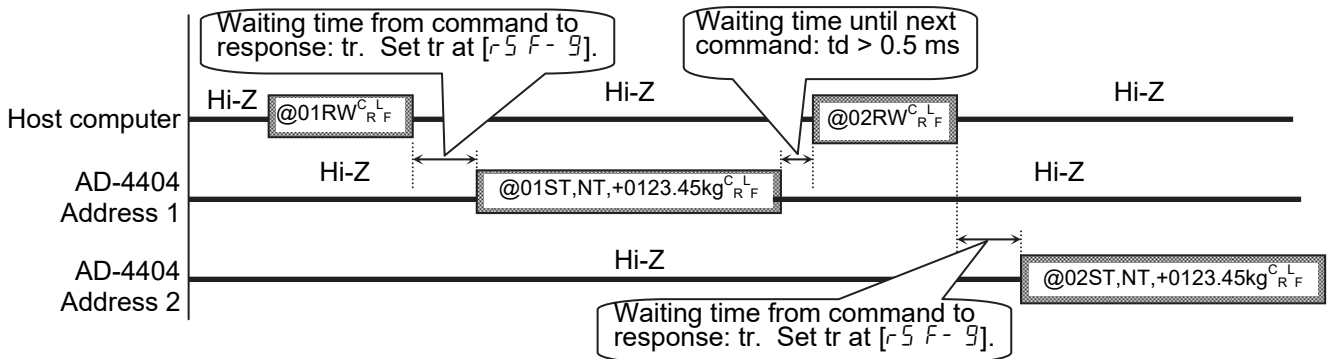

9.2.4. Communication Modes

- There are six following.

Stream Mode

The data is output on each display update. If the data can not be output completely due to a slow baud rate, the data is output at the next update.

Auto Print Mode

The data is automatically printed on batch finish.

Total Print Mode

When entering the PRINT command, data is printed.

The PRINT command can be assigned to the control I/O, OP-05, F1 key or F2 key

Manual Print Mode

When the preset print key is pressed or the assigned terminal is connected, the data is output.

Command Mode

This mode is used to control the indicator, to store parameters and to read data or parameters. Use multiple drop connection.

Jet Steam Mode

The weighing data and state is output 100 time/s. The data is the gross or net value. The format is the same as the command RGRS or RNET.

Set the baud rate to 38400 bps. If another baud rate is used, mis-sampling may occur. Output data is repeated according to the number of Sampling frequency divider $[UEnF-3]$.

9.2.5. General Data Format

- This format is used for the command mode and jet stream mode.

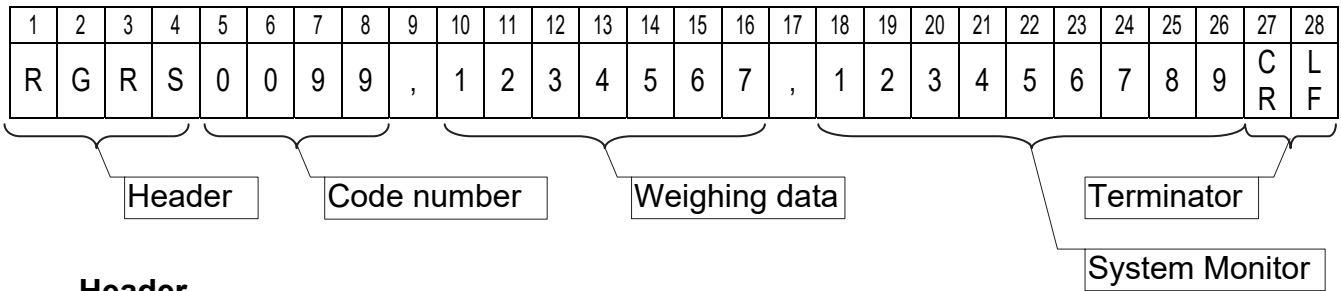

Header

Command is echoed. The echoed command is 4 characters

Code number

The code is 4 characters. A comma "," is appended after this.

Weighing data

Data uses BCD code, is 7 figures and does not include a decimal point.

When data is negative, a minus sign is appended to the head.

A comma "," is appended after this.

Status

The status of weighing data and sequence are indicated at 36 bits.

The status bits synchronizes with control I/O and options.

9 figure is ASCII code. Each lower 4 bits are used.

Each upper 3 bits are fixed to "101".

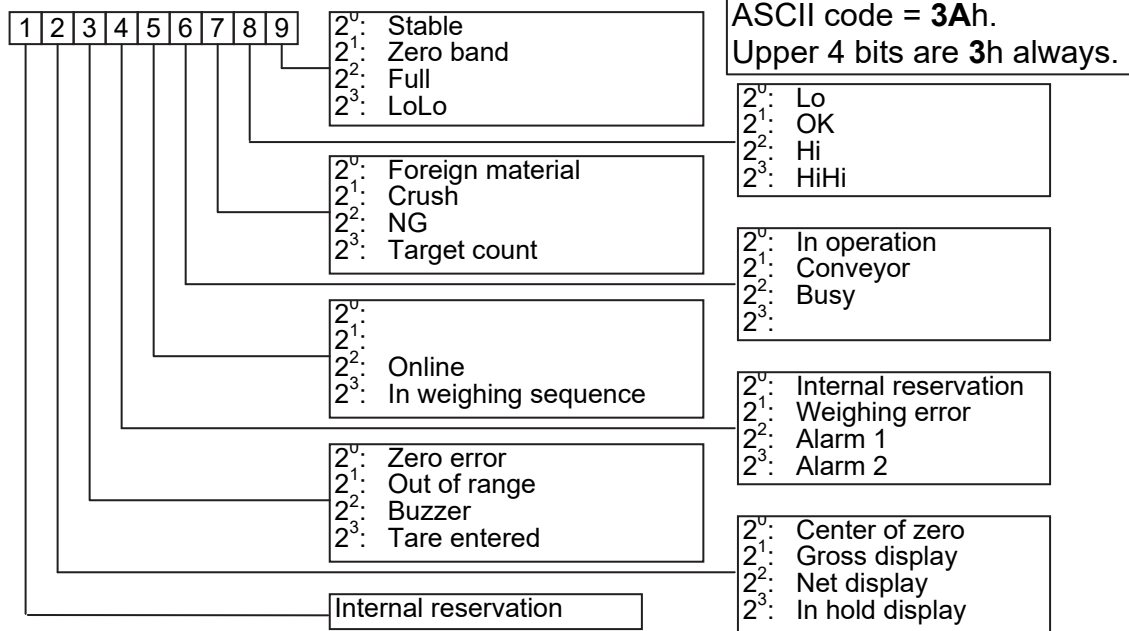

Terminator

Select a terminator at Terminator [*r5 F-7*]

CR or CR + LF

CR: **0Dh**, LF: **0Ah**

9.2.6. A&D Data Format

- This format is used for stream mode, auto print mode and total print.
- This format is compatible with the AD-4325 indicator.

1	2	3	4	5	6	7	8	9	10	11	12	13	14	15	16	17	18
S	T	,	N	T	,	+	0	0	1	2	.	3	4	k	g	CR	LF

Header 1

ST Stable
 US Unstable
 LO Out of range

Header 2

GS Gross value
 NT Net value
 TR Tare value

Weighing data

The data uses BCD code, is 7 figures and includes a decimal point.
 When the data is negative, a minus sign is appended to the head.
 When the data is out of range, all numerical characters are space (**20h**).

Unit

kg, g or t

Terminator

CR or CR + LF

CR: **0Dh**, LF: **0Ah**

9.2.7. Address

- Set the address at Address [r5 F- 8]. The address can be entered as a number between 1 and 99.
- 32 units can be connected to a computer. Use multiple drop connection.
- Address [r5 F- 8] is always appended to the data in all modes of Communication mode [r5 F- 2].
- An address of three figures can be used, when "0" is appended to front of the address. If three figures are used, the response of the indicator becomes three figures. Example: Address 001 to 099 can be used.

Caution

- **Do not assign the same address number to multiple units.**



Broadcast Address

When the address @00 is used, a command is sent to all units at the same time.
Example:

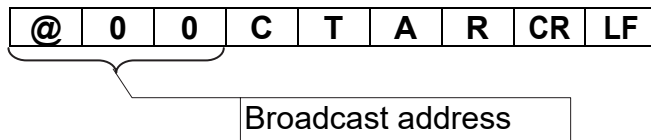

9.2.8. Command List

Monitor Commands

Name	Code	Description
Read displayed value	RDSP	Data specified at Output data [r5 F-1]
Read gross value	RGRS	
Read net value	RNET	
Read tare value	RTAR	
Read weighing result	RFIN	
Read setpoint	RSPT _{xxxx}	Comparison parameters
Read code data	RCOD _{xxxx}	The details of the code.
Read total data of code	RTTL _{xxxx}	Total weight, total count
Read error code	RERR	

xxxx: Code number appended to the leading zeros. Example: 0099

Write Commands

Name	Code	Description
Store setpoints	WSPT _{xxxx}	Comparison parameters
Store code data without total	WCOD _{xxxx}	To store all parameters of the code.
Store all code data	WCOX _{xxxx}	To store all parameters of the code.

xxxx: Code number appended to the leading zeros. Example: 0099

Control Commands

Name	Code	Description
Make zero display	CZER	
Tare	CTAR	
Tare clear	CCTR	
Change to gross display	CGRS	
Change to net display	CENT	
Call code	CCOD _{xxxx}	
Cancel the last result	CCAC	
Start operation	COPR	
Stop operation	CSTD	
Emergency stop	CSTP	
Clear total data of code	CDTL _{xxxx}	Total data is set to 0.
Clear total data of all code	CETL	All total data is set to 0.
Reset an error	CRER	
No operation	CNOP	

xxxx: Code number appended to the leading zeros. Example: 0099.

Response Error Code

Response	Description	Note
?E	The format of command is not correct.	When an address is used, the address is appended to the response.
VE	The data of command is not correct.	
IE	Indicator is busy.	

9.2.9. ASCII Code for Display Characters

- The characters use special code for the name of the code. Therefore, some characters are not the same as U.S. code.

	Lower bits								
	0	1	2	3	4	5	6	7	
Upper bits	0			Space	0	@	P	Space	p
	1			!	1	A	Q	a	q
	2			"	2	B	R	b	r
	3			#	3	C	S	c	s
	4			\$	4	D	T	d	t
	5			%	5	E	U	e	u
	6			&	6	F	V	f	v
	7			'	7	G	W	g	w
	8			(8	H	X	h	x
	9)	9	I	Y	i	y
	A	LF		*	:	J	Z	j	z
	B			+	;	K	[k	{
	C			,	<	L	¥	l	
	D	CR		-	=	M]	m	}
	E			.	>	N	^	n	●
	F			/	?	O	_	o	○

9.2.10. Protocol (Communication Procedure and Format)

Caution When using the flash memory ($\text{[0thF-11]} = \text{2}$, "Store in flash memory") and storing new code data with "Write Commands", new code data is not stored in the flash memory and the code data stored in the flash memory has effect after restarting the power supply. If storing the code data into the flash memory is needed, perform the remote setup program of "10.5. Remote Operation".

Monitor Commands

Command	Protocol
RDSP Read displayed value	Current displayed the weighing value is output. 26 characters. Reply format at gross . Computer $\text{[RDSP}^{\text{C L}}_{\text{R F}}\text{]}$ AD-4404 $\text{[RGRS1234,1234567,123456789}^{\text{C L}}_{\text{R F}}\text{]}$
	Reply format at net . Code number, Weight value, Status Computer $\text{[RDSP}^{\text{C L}}_{\text{R F}}\text{]}$ AD-4404 $\text{[RNET1234,1234567,123456789}^{\text{C L}}_{\text{R F}}\text{]}$
RGRS Read gross value	Current gross value is output. 26 characters. Gross value is 7 figures with "-" sign at MSB when negative value and without decimal point. Computer $\text{[RGRS}^{\text{C L}}_{\text{R F}}\text{]}$ AD-4404 $\text{[RGRS1234,1234567,123456789}^{\text{C L}}_{\text{R F}}\text{]}$ Code number, Gross value, Status
	Current net value is output. 26 characters. Net value is 7 figures with "-" sign at MSB when negative value and without decimal point. Computer $\text{[RNET}^{\text{C L}}_{\text{R F}}\text{]}$ AD-4404 $\text{[RNET1234,1234567,123456789}^{\text{C L}}_{\text{R F}}\text{]}$ Code number, Net value, Status
RTAR Read tare value	Current tare value is output. 26 characters. Tare value is 7 figures with "-" sign at MSB when negative value and without decimal point. Computer $\text{[RTAR}^{\text{C L}}_{\text{R F}}\text{]}$ AD-4404 $\text{[RTAR1234,1234567,123456789}^{\text{C L}}_{\text{R F}}\text{]}$ Code number, Tare value, Status
	Weighing result is output. 26 characters. Net value is 7 figures with "-" sign at MSB when negative value and without decimal point. Computer $\text{[RFIN}^{\text{C L}}_{\text{R F}}\text{]}$ Code number, Net value, Status AD-4404 $\text{[RFIN1234,1234567,123456789}^{\text{C L}}_{\text{R F}}\text{]}$

Command	Protocol																																																								
<p>RSPT Read setpoint or Read comparison parameters</p>	<p style="text-align: right;">64 characters.</p> <p>This command outputs setpoints of a selected code. Parameters are 7 figures with "-" sign at MSB when negative value and without decimal point. If code number is replaced with space codes (20h), the current setpoints are output.</p> <p>Computer RSPT0034^{C L}_{R F} AD-4404 RSPT0034,1234567,1234567,1234567,</p> <p style="text-align: center;">Code number, Hi, Lo, HiHi, LoLo, Zero Band, Full</p> <p style="text-align: center;">,1234567,1234567,1234567,1234567^{C L}_{R F}</p>																																																								
<p>RCOD Read code</p>	<p style="text-align: right;">226 characters.</p> <p>This command outputs all data of a selected code. Parameters are 7 figures with "-" sign at MSB when negative value and without decimal point. If code number is replaced with space codes (20h), the current code is output.</p> <p>Computer RCOD0034^{C L}_{R F} Code number AD-4404 RCOD0034,12345678...,123456789^{C L}_{R F}</p> <table border="1" data-bbox="592 987 1385 2056"> <thead> <tr> <th>Output item order</th> <th>Length</th> </tr> </thead> <tbody> <tr><td>Code number</td><td>RCOD + 4</td></tr> <tr><td>Code name</td><td>12 + 3 spaces</td></tr> <tr><td>Target</td><td>7</td></tr> <tr><td>Hi</td><td>7</td></tr> <tr><td>Lo</td><td>7</td></tr> <tr><td>HiHi</td><td>7</td></tr> <tr><td>LoLo</td><td>7</td></tr> <tr><td>Zero band</td><td>7</td></tr> <tr><td>Full</td><td>7</td></tr> <tr><td>Preset tare</td><td>7</td></tr> <tr><td>Target count</td><td>7</td></tr> <tr><td>Total count</td><td>7</td></tr> <tr><td>OK count</td><td>7</td></tr> <tr><td>NG count</td><td>7</td></tr> <tr><td>Hi count</td><td>7</td></tr> <tr><td>Lo count</td><td>7</td></tr> <tr><td>HiHi count</td><td>7</td></tr> <tr><td>LoLo count</td><td>7</td></tr> <tr><td>Foreign matter count</td><td>7</td></tr> <tr><td>Duplication count</td><td>7</td></tr> <tr><td>Crush count</td><td>7</td></tr> <tr><td>Maximum</td><td>7</td></tr> <tr><td>Minimum</td><td>7</td></tr> <tr><td>Average</td><td>7</td></tr> <tr><td>Standard deviation σ_{n-1}</td><td>7</td></tr> <tr><td>Population standard deviation σ_n</td><td>7</td></tr> <tr><td>Total weight</td><td>9</td></tr> </tbody> </table>	Output item order	Length	Code number	RCOD + 4	Code name	12 + 3 spaces	Target	7	Hi	7	Lo	7	HiHi	7	LoLo	7	Zero band	7	Full	7	Preset tare	7	Target count	7	Total count	7	OK count	7	NG count	7	Hi count	7	Lo count	7	HiHi count	7	LoLo count	7	Foreign matter count	7	Duplication count	7	Crush count	7	Maximum	7	Minimum	7	Average	7	Standard deviation σ_{n-1}	7	Population standard deviation σ_n	7	Total weight	9
Output item order	Length																																																								
Code number	RCOD + 4																																																								
Code name	12 + 3 spaces																																																								
Target	7																																																								
Hi	7																																																								
Lo	7																																																								
HiHi	7																																																								
LoLo	7																																																								
Zero band	7																																																								
Full	7																																																								
Preset tare	7																																																								
Target count	7																																																								
Total count	7																																																								
OK count	7																																																								
NG count	7																																																								
Hi count	7																																																								
Lo count	7																																																								
HiHi count	7																																																								
LoLo count	7																																																								
Foreign matter count	7																																																								
Duplication count	7																																																								
Crush count	7																																																								
Maximum	7																																																								
Minimum	7																																																								
Average	7																																																								
Standard deviation σ_{n-1}	7																																																								
Population standard deviation σ_n	7																																																								
Total weight	9																																																								

Command	Protocol																																				
<p>RTTL Read total data of code</p>	<p style="text-align: right;">138 characters.</p> <p>This command outputs total data of a selected code. Parameters are 7 figures with "-" sign at MSB when negative value and without decimal point. If code number is replaced with space codes (20h), the current total data of code are output.</p> <p>Computer RTTL0034^{C L}_{R F}</p> <hr/> <p>AD-4404 RTTL0034,1234567,...,123456789^{C L}_{R F}</p> <p style="text-align: center;">Code number, Total count, Total weight</p> <table border="1" style="width: 100%; border-collapse: collapse;"> <thead> <tr> <th>Output item order</th> <th>Length</th> </tr> </thead> <tbody> <tr><td>Code number</td><td>RTTL + 4</td></tr> <tr><td>Total count</td><td>7</td></tr> <tr><td>OK count</td><td>7</td></tr> <tr><td>NG count</td><td>7</td></tr> <tr><td>Hi count</td><td>7</td></tr> <tr><td>Lo count</td><td>7</td></tr> <tr><td>HiHi count</td><td>7</td></tr> <tr><td>LoLo count</td><td>7</td></tr> <tr><td>Foreign matter count</td><td>7</td></tr> <tr><td>Duplication count</td><td>7</td></tr> <tr><td>Crush count</td><td>7</td></tr> <tr><td>Maximum</td><td>7</td></tr> <tr><td>Minimum</td><td>7</td></tr> <tr><td>Average</td><td>7</td></tr> <tr><td>Standard deviation σ_{n-1}</td><td>7</td></tr> <tr><td>Population standard deviation σ_n</td><td>7</td></tr> <tr><td>Total weight</td><td>9</td></tr> </tbody> </table>	Output item order	Length	Code number	RTTL + 4	Total count	7	OK count	7	NG count	7	Hi count	7	Lo count	7	HiHi count	7	LoLo count	7	Foreign matter count	7	Duplication count	7	Crush count	7	Maximum	7	Minimum	7	Average	7	Standard deviation σ_{n-1}	7	Population standard deviation σ_n	7	Total weight	9
Output item order	Length																																				
Code number	RTTL + 4																																				
Total count	7																																				
OK count	7																																				
NG count	7																																				
Hi count	7																																				
Lo count	7																																				
HiHi count	7																																				
LoLo count	7																																				
Foreign matter count	7																																				
Duplication count	7																																				
Crush count	7																																				
Maximum	7																																				
Minimum	7																																				
Average	7																																				
Standard deviation σ_{n-1}	7																																				
Population standard deviation σ_n	7																																				
Total weight	9																																				
<p>RERR Read error code</p>	<p style="text-align: right;">12 characters.</p> <p>This command outputs current error code number and type. Each left figure 0: normal, 1: error Each right figure is error code.</p> <p>Computer RERR^{C L}_{R F}</p> <hr/> <p>AD-4404 RERR 00 00 00 10^{C L}_{R F}</p> <p style="text-align: center;">Alarm2, Alarm1, Zero error, Weighing sequence error</p> <p>Example: Above code indicates weighing sequence error and "Weighing sequence is stopped" of error code 0.</p>																																				



Write Commands

Command	Protocol																								
<p>WSPT Store setpoints Store comparison parameters</p>	<p>64 characters.</p> <p>This command stores setpoints of a selected code. Parameters are 7 figures with "-" sign at MSB when negative value and without decimal point.</p> <p>Computer WSPT0034,1234567,1234567,1234567,1234567,1234567, AD-4404</p> <p style="text-align: center;">Code number, Target, Hi, Lo, HiHi, LoLo, Zero Band, Full, Code number</p> <p style="text-align: center;">1234567,1234567 C L R F</p> <p style="text-align: right;">WSPT0034 C L R F</p>																								
<p>WCOD Store code data without total</p>	<p>96 characters.</p> <p>This command stores all data of a selected code. Parameters are 7 figures with "-" sign at MSB when negative value and without decimal point. If code number is replaced with space codes (20h), data is stored into the current code.</p> <p>Computer WCOD0034,123456...,1234567 C L R F AD-4404</p> <p style="text-align: center;">Code number</p> <p style="text-align: right;">WCOD0034 C L R F</p> <table border="1" data-bbox="571 1019 1364 1473" style="width: 100%; border-collapse: collapse;"> <thead> <tr> <th>Output item order</th> <th>Length</th> </tr> </thead> <tbody> <tr> <td>Code number</td> <td>WCOD + 4</td> </tr> <tr> <td>Code name</td> <td>12 + 3 spaces</td> </tr> <tr> <td>Target</td> <td>7</td> </tr> <tr> <td>Hi</td> <td>7</td> </tr> <tr> <td>Lo</td> <td>7</td> </tr> <tr> <td>HiHi</td> <td>7</td> </tr> <tr> <td>LoLo</td> <td>7</td> </tr> <tr> <td>Zero band</td> <td>7</td> </tr> <tr> <td>Full</td> <td>7</td> </tr> <tr> <td>Preset tare</td> <td>7</td> </tr> <tr> <td>Target count</td> <td>7</td> </tr> </tbody> </table>	Output item order	Length	Code number	WCOD + 4	Code name	12 + 3 spaces	Target	7	Hi	7	Lo	7	HiHi	7	LoLo	7	Zero band	7	Full	7	Preset tare	7	Target count	7
Output item order	Length																								
Code number	WCOD + 4																								
Code name	12 + 3 spaces																								
Target	7																								
Hi	7																								
Lo	7																								
HiHi	7																								
LoLo	7																								
Zero band	7																								
Full	7																								
Preset tare	7																								
Target count	7																								

Command	Protocol																																																							
<p>WCOX Read code</p>	<p style="text-align: right;">226 characters.</p> <p>This command outputs all data of a selected code. Parameters are 7 figures with "-" sign at MSB when negative value and without decimal point. If code number is replaced with space codes (20h), the current code is output.</p> <p>Computer <table border="1" style="display: inline-table; vertical-align: middle;"><tr><td style="padding: 2px;">WCOX0034^{C L}_{R F}</td></tr></table> Code number</p> <p>AD-4404 <table border="1" style="display: inline-table; vertical-align: middle;"><tr><td style="padding: 2px;">WCOX0034,12345678...,123456789^{C L}_{R F}</td></tr></table></p>	WCOX0034 ^{C L} _{R F}	WCOX0034,12345678...,123456789 ^{C L} _{R F}																																																					
	WCOX0034 ^{C L} _{R F}																																																							
WCOX0034,12345678...,123456789 ^{C L} _{R F}																																																								
<table border="1" style="width: 100%; border-collapse: collapse;"> <thead> <tr> <th style="width: 70%;">Output item order</th> <th style="width: 30%;">Length</th> </tr> </thead> <tbody> <tr><td>Code number</td><td>WCOX + 4</td></tr> <tr><td>Code name</td><td>12 + 3 spaces</td></tr> <tr><td>Target</td><td>7</td></tr> <tr><td>Hi</td><td>7</td></tr> <tr><td>Lo</td><td>7</td></tr> <tr><td>HiHi</td><td>7</td></tr> <tr><td>LoLo</td><td>7</td></tr> <tr><td>Zero band</td><td>7</td></tr> <tr><td>Full</td><td>7</td></tr> <tr><td>Preset tare</td><td>7</td></tr> <tr><td>Target count</td><td>7</td></tr> <tr><td>Total count</td><td>7</td></tr> <tr><td>OK count</td><td>7</td></tr> <tr><td>NG count</td><td>7</td></tr> <tr><td>Hi count</td><td>7</td></tr> <tr><td>Lo count</td><td>7</td></tr> <tr><td>HiHi count</td><td>7</td></tr> <tr><td>LoLo count</td><td>7</td></tr> <tr><td>Foreign matter count</td><td>7</td></tr> <tr><td>Duplication count</td><td>7</td></tr> <tr><td>Crush count</td><td>7</td></tr> <tr><td>Maximum</td><td>7</td></tr> <tr><td>Minimum</td><td>7</td></tr> <tr><td>Average</td><td>7</td></tr> <tr><td>Standard deviation σ_{n-1}</td><td>7</td></tr> <tr><td>Population standard deviation σ_n</td><td>7</td></tr> <tr><td>Total weight</td><td>9</td></tr> </tbody> </table>	Output item order	Length	Code number	WCOX + 4	Code name	12 + 3 spaces	Target	7	Hi	7	Lo	7	HiHi	7	LoLo	7	Zero band	7	Full	7	Preset tare	7	Target count	7	Total count	7	OK count	7	NG count	7	Hi count	7	Lo count	7	HiHi count	7	LoLo count	7	Foreign matter count	7	Duplication count	7	Crush count	7	Maximum	7	Minimum	7	Average	7	Standard deviation σ_{n-1}	7	Population standard deviation σ_n	7	Total weight	9
Output item order	Length																																																							
Code number	WCOX + 4																																																							
Code name	12 + 3 spaces																																																							
Target	7																																																							
Hi	7																																																							
Lo	7																																																							
HiHi	7																																																							
LoLo	7																																																							
Zero band	7																																																							
Full	7																																																							
Preset tare	7																																																							
Target count	7																																																							
Total count	7																																																							
OK count	7																																																							
NG count	7																																																							
Hi count	7																																																							
Lo count	7																																																							
HiHi count	7																																																							
LoLo count	7																																																							
Foreign matter count	7																																																							
Duplication count	7																																																							
Crush count	7																																																							
Maximum	7																																																							
Minimum	7																																																							
Average	7																																																							
Standard deviation σ_{n-1}	7																																																							
Population standard deviation σ_n	7																																																							
Total weight	9																																																							

Control Commands

Command	Protocol
CZER Make zero display	Re-zero command. Computer $\overline{\text{CZER}}^{\text{C L}}_{\text{R F}}$ AD-4404 $\text{CZER}^{\text{C L}}_{\text{R F}}$
CTAR Tare	Tare command. Computer $\overline{\text{CTAR}}^{\text{C L}}_{\text{R F}}$ AD-4404 $\text{CTAR}^{\text{C L}}_{\text{R F}}$
CCTR Tare clear	To clear the tare command. Computer $\overline{\text{CCTR}}^{\text{C L}}_{\text{R F}}$ AD-4404 $\text{CCTR}^{\text{C L}}_{\text{R F}}$
CGRS Change to gross display	To display the current gross value. Computer $\overline{\text{CGRS}}^{\text{C L}}_{\text{R F}}$ AD-4404 $\text{CGRS}^{\text{C L}}_{\text{R F}}$
CENT Change to net display	To display the current net value. Computer $\overline{\text{CENT}}^{\text{C L}}_{\text{R F}}$ AD-4404 $\text{CENT}^{\text{C L}}_{\text{R F}}$
CCOD Recall code	To recall the code. Computer $\overline{\text{CCOD1234}}^{\text{C L}}_{\text{R F}}$ Code number AD-4404 $\text{CCOD1234}^{\text{C L}}_{\text{R F}}$
CCAC Cancel the last result	To clear the last total data. Computer $\overline{\text{CCAC}}^{\text{C L}}_{\text{R F}}$ AD-4404 $\text{CCAC}^{\text{C L}}_{\text{R F}}$
COPR Operation	To start the weighing sequence. Computer $\overline{\text{COPR}}^{\text{C L}}_{\text{R F}}$ AD-4404 $\text{COPR}^{\text{C L}}_{\text{R F}}$
CSTD Stop	To stop the current sequence. Computer $\overline{\text{CSTD}}^{\text{C L}}_{\text{R F}}$ AD-4404 $\text{CSTD}^{\text{C L}}_{\text{R F}}$
CSTP Emergency stop	To stop the current sequence. Computer $\overline{\text{CSTP}}^{\text{C L}}_{\text{R F}}$ AD-4404 $\text{CSTP}^{\text{C L}}_{\text{R F}}$
CDTL Clear total data of code	Total data of specified code is set to 0. Computer $\overline{\text{CDTL1234}}^{\text{C L}}_{\text{R F}}$ Code number AD-4404 $\text{CDTL1234}^{\text{C L}}_{\text{R F}}$
CETL Clear total data of all code	All total data is set to 0. Computer $\overline{\text{CETL}}^{\text{C L}}_{\text{R F}}$ AD-4404 $\text{CETL}^{\text{C L}}_{\text{R F}}$

Command	Protocol
CRER Reset an error	Computer $\overline{\text{CRER}}_{\text{RF}}^{\text{CL}}$  AD-4404 $\text{CRER}_{\text{RF}}^{\text{CL}}$
CNOP No operation	Computer $\overline{\text{CNOP}}_{\text{RF}}^{\text{CL}}$  AD-4404 $\text{CNOP}_{\text{RF}}^{\text{CL}}$



9.3. Modbus Interface for RS-485

- Modbus is a kind of connection that is used with the RS-485 serial interface.
- Communication mode is Modbus RTU.
- It is not necessary to make a program for communication between these units. The communication uses the following memories of the monitor unit or computer.
- Data is specified with reference No. and address No. Refer to the instruction for Modbus of the monitor unit or computer.
- The connection for Modbus is as follows.

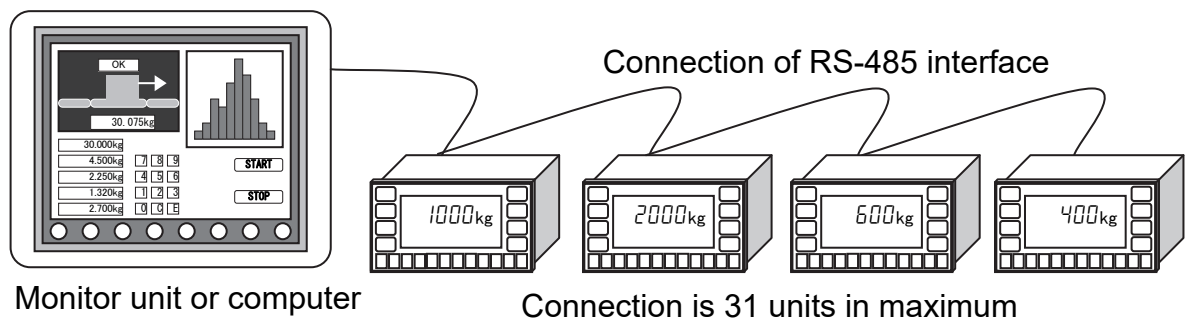

Monitor unit or computer
Monitor example: Monitouch V6 (checked at 2002)

- Set the following parameters of RS-485 interface. Refer to " 11. Function List"

Function and parameter		Description
r5 F-1	Output data	Select either parameter.
r5 F-2	Communication mode	Set MODBUS
6	MODBUS	
r5 F-3	Baud rate	Select either parameter.
r5 F-4	Parity check	
r5 F-5	Character length	
r5 F-6	Stop bits	
r5 F-7	Terminator	
r5 F-8	Address	Set unique address number

Reference No.

Type	Reference No.	Description
Coil	0	The same as input bits of control I/O
Input status	1	The same as output bits of control I/O
Input register	3	Register to read data
Holding register	4	Register to read and write data

Coil (Reference No.=0. Output bits)

Address	Description	Address	Description
1	Zero	9	Cancel last result
2	(Internal reservation)	10	Print total
3	Tare	11	Forced finish
4	Tare clear	12	Error reset
6	Operate	13	Manual print
7	Stop	14	Net / Gross
8	Stop buzzer	15	Clear all total

Input Status (Reference No.=1. Input bits)

A code has three items in a **total status**.

Example for code 0 is as follows:

Total status of the code 0	
Address	Description
49	Total in process
50	Over of weighing data
51	Over total count

Input Status (Reference No.=1)		Input Status (Reference No.=1)	
Address	Description	Address	Description
17	Stable	39	Alarm 1
18	Zero band	40	Alarm 2
19	Full	41	Zero error
20	LoLo	42	Out of weighing range
21	Lo	43	Buzzer
22	OK	44	Tared
23	Hi	45	Center of zero
24	HiHi	46	Gross display
25	Foreign matter	47	Net display
26	Duplication	48	Hold display
27	NG	49 to 51	Total status of code 0
28	Target count	305 to 307	Total status of code 1
29	Operate	561 to 563	Total status of code 2
30	Conveyor	817 to 819	Total status of code 3
31	BUSY	1073 to 1075	Total status of code 4
32	BUSY for foreign matter	1329 to 1331	Total status of code 5
33	Crush	1585 to 1587	Total status of code 6
34	Finish weighing	1841 to 1843	Total status of code 7
35	Online. 1 Hz pulse is output, when weighing is able.	2097 to 2099	Total status of code 8
		2353 to 2355	Total status of code 9
36	Internal reservation	2609 to 2611	Total status of code 10
		2865 to 2867	Total status of code 11
37	Weighing sequence error	3121 to 3123	Total status of code 12
38			

Input Status (Reference No.=1)		Input Status (Reference No.=1)	
Address	Description	Address	Description
3377 to 3379	Total status of code 13	14641 to 14643	Total status of code 57
3633 to 3635	Total status of code 14	14897 to 14899	Total status of code 58
3889 to 3891	Total status of code 15	15153 to 15155	Total status of code 59
4145 to 4147	Total status of code 16	15409 to 15411	Total status of code 60
4401 to 4403	Total status of code 17	15665 to 15667	Total status of code 61
4657 to 4659	Total status of code 18	15921 to 15923	Total status of code 62
4913 to 4915	Total status of code 19	16177 to 16179	Total status of code 63
5169 to 5171	Total status of code 20	16433 to 16435	Total status of code 64
5425 to 5427	Total status of code 21	16689 to 16691	Total status of code 65
5681 to 5683	Total status of code 22	16945 to 16947	Total status of code 66
5937 to 5939	Total status of code 23	17201 to 17203	Total status of code 67
6193 to 6195	Total status of code 24	17457 to 17459	Total status of code 68
6449 to 6451	Total status of code 25	17713 to 17715	Total status of code 69
6705 to 6707	Total status of code 26	17969 to 17971	Total status of code 70
6961 to 6963	Total status of code 27	18225 to 18227	Total status of code 71
7217 to 7219	Total status of code 28	18481 to 18483	Total status of code 72
7473 to 7475	Total status of code 29	18737 to 18739	Total status of code 73
7729 to 7731	Total status of code 30	18993 to 18995	Total status of code 74
7985 to 7987	Total status of code 31	19249 to 19251	Total status of code 75
8241 to 8243	Total status of code 32	19505 to 19507	Total status of code 76
8497 to 8499	Total status of code 33	19761 to 19763	Total status of code 77
8753 to 8755	Total status of code 34	20017 to 20019	Total status of code 78
9009 to 9011	Total status of code 35	20273 to 20275	Total status of code 79
9265 to 9267	Total status of code 36	20529 to 20531	Total status of code 80
9521 to 9523	Total status of code 37	20785 to 20787	Total status of code 81
9777 to 9779	Total status of code 38	21041 to 21043	Total status of code 82
10033 to 10035	Total status of code 39	21297 to 21299	Total status of code 83
10289 to 10291	Total status of code 40	21553 to 21555	Total status of code 84
10545 to 10547	Total status of code 41	21809 to 21811	Total status of code 85
10801 to 10803	Total status of code 42	22065 to 22067	Total status of code 86
11057 to 11059	Total status of code 43	22321 to 22323	Total status of code 87
11313 to 11315	Total status of code 44	22577 to 22579	Total status of code 88
11569 to 11571	Total status of code 45	22833 to 22835	Total status of code 89
11825 to 11827	Total status of code 46	23089 to 23091	Total status of code 90
12081 to 12083	Total status of code 47	23345 to 23347	Total status of code 91
12337 to 12339	Total status of code 48	23601 to 23603	Total status of code 92
12593 to 12595	Total status of code 49	23857 to 23859	Total status of code 93
12849 to 12851	Total status of code 50	24113 to 24115	Total status of code 94
13105 to 13107	Total status of code 51	24369 to 24371	Total status of code 95
13361 to 13363	Total status of code 52	24625 to 24627	Total status of code 96
13617 to 13619	Total status of code 53	24881 to 24883	Total status of code 97
13873 to 13875	Total status of code 54	25137 to 25139	Total status of code 98
14129 to 14131	Total status of code 55	25393 to 25395	Total status of code 99
14385 to 14387	Total status of code 56		

Input Register (Reference No.=3. To read words)

A word, occupies an address, is length of 16 bits.

A code has these items in a **total data**.

Example for code 0 is as follows:

Total data of the code 0	
Address	Description
33, 34	Total count
35, 36	OK count
37, 38	NG count
39, 40	Hi count
41, 42	Lo count
43, 44	HiHi count
45, 46	LoLo count
47, 48	Count of foreign matter

Total data of the code 0	
Address	Description
49, 50	Count of duplication
51, 52	Count of crush
53, 54	Maximum data
55, 56	Minimum data
57, 58	Average data
59, 60	Standard deviation σ_{n-1}
61, 62	Population standard deviation σ_n
63, 64	Total weight

Input Register (Reference No.=3) To read data		Input Register (Reference No.=3) To read data	
Address	Description	Address	Description
1	Decimal point	2849 to 2879	Total data of the code 11
2	Unit. 0: blank, 1: g, 2: kg, 3: t, 4: lb	3105 to 3135	Total data of the code 12
		3361 to 3391	Total data of the code 13
3, 4	Tare value	3617 to 3647	Total data of the code 14
5, 6	Net value	3873 to 3903	Total data of the code 15
7, 8	Gross value	4129 to 4159	Total data of the code 16
9	Active code No.	4385 to 4415	Total data of the code 17
10		4641 to 4671	Total data of the code 18
11		4897 to 4927	Total data of the code 19
12	Sequence error	5153 to 5183	Total data of the code 20
13	Zero error No.	5409 to 5439	Total data of the code 21
14	Alarm 1 No.	5665 to 5695	Total data of the code 22
15	Alarm 2 No.	5921 to 5951	Total data of the code 23
16	Operation mode 0: Enable, 1: Disable	6177 to 6207	Total data of the code 24
		6433 to 6463	Total data of the code 25
17	Weight value at the time weighing finished	6689 to 6719	Total data of the code 26
		6945 to 6975	Total data of the code 27
33 to 63	Total data of the code 0	7201 to 7231	Total data of the code 28
289 to 319	Total data of the code 1	7457 to 7487	Total data of the code 29
545 to 575	Total data of the code 2	7713 to 7743	Total data of the code 30
801 to 831	Total data of the code 3	7969 to 7999	Total data of the code 31
1057 to 1087	Total data of the code 4	8225 to 8255	Total data of the code 32
1313 to 1343	Total data of the code 5	8481 to 8511	Total data of the code 33
1569 to 1599	Total data of the code 6	8737 to 8767	Total data of the code 34
1825 to 1855	Total data of the code 7	8993 to 9023	Total data of the code 35
2081 to 2111	Total data of the code 8	9249 to 9279	Total data of the code 36
2337 to 2367	Total data of the code 9	9505 to 9535	Total data of the code 37
2593 to 2623	Total data of the code 10	9761 to 9791	Total data of the code 38

Input Register (Reference No.=3) To read data		Input Register (Reference No.=3) To read data	
Address	Description	Address	Description
10017 to 10047	Total data of the code 39	17953 to 17983	Total data of the code 70
10273 to 10303	Total data of the code 40	18209 to 18239	Total data of the code 71
10529 to 10559	Total data of the code 41	18465 to 18495	Total data of the code 72
10785 to 10815	Total data of the code 42	18721 to 18751	Total data of the code 73
11041 to 11071	Total data of the code 43	18977 to 19007	Total data of the code 74
11297 to 11327	Total data of the code 44	19233 to 19263	Total data of the code 75
11553 to 11583	Total data of the code 45	19489 to 19519	Total data of the code 76
11809 to 11839	Total data of the code 46	19745 to 19775	Total data of the code 77
12065 to 12095	Total data of the code 47	20001 to 20031	Total data of the code 78
12321 to 12351	Total data of the code 48	20257 to 20287	Total data of the code 79
12577 to 12607	Total data of the code 49	20513 to 20543	Total data of the code 80
12833 to 12863	Total data of the code 50	20769 to 20799	Total data of the code 81
13089 to 13119	Total data of the code 51	21025 to 21055	Total data of the code 82
13345 to 13375	Total data of the code 52	21281 to 21311	Total data of the code 83
13601 to 13631	Total data of the code 53	21537 to 21567	Total data of the code 84
13857 to 13887	Total data of the code 54	21793 to 21823	Total data of the code 85
14113 to 14143	Total data of the code 55	22049 to 22079	Total data of the code 86
14369 to 14399	Total data of the code 56	22305 to 22335	Total data of the code 87
14625 to 14655	Total data of the code 57	22561 to 22591	Total data of the code 88
14881 to 14911	Total data of the code 58	22817 to 22847	Total data of the code 89
15137 to 15167	Total data of the code 59	23073 to 23103	Total data of the code 90
15393 to 15423	Total data of the code 60	23329 to 23359	Total data of the code 91
15649 to 15679	Total data of the code 61	23585 to 23615	Total data of the code 92
15905 to 15935	Total data of the code 62	23841 to 23871	Total data of the code 93
16161 to 16191	Total data of the code 63	24097 to 24127	Total data of the code 94
16417 to 16447	Total data of the code 64	24353 to 24383	Total data of the code 95
16673 to 16703	Total data of the code 65	24609 to 24639	Total data of the code 96
16929 to 16959	Total data of the code 66	24865 to 24895	Total data of the code 97
17185 to 17215	Total data of the code 67	25121 to 25151	Total data of the code 98
17441 to 17471	Total data of the code 68	25377 to 25407	Total data of the code 99
17697 to 17727	Total data of the code 69		

Holding Register (Reference No.=4. To write words)

A word, occupies an address, is 16 bits in length.

A code has these items in a **comparison data**.

Example for code 0 is as follows:

Comparison data of the code 0	
Address	Description
1	Name, 1 to 2 characters
2	Name, 3 to 4 characters
3	Name, 5 to 6 characters
4	Name, 7 to 8 characters
5	Name, 9 to 10 characters
6	Name, 11 to 12 characters
7,8	Target value
9,10	Hi

Comparison data of the code 0	
Address	Description
11, 12	Lo
13, 14	HiHi
15, 16	LoLo
17, 18	Zero band
19, 20	Full
21, 22	Tare mass
23, 24	Target count

Holding Register (Reference No.=4) To write comparison data		Holding Register (Reference No.=4) To write comparison data	
Address	Description	Address	Description
1 to 24	C.D. of the code 0	7169 to 7191	C.D. of the code 28
257 to 280	C.D. of the code 1	7425 to 7447	C.D. of the code 29
513 to 535	C.D. of the code 2	7681 to 7703	C.D. of the code 30
769 to 791	C.D. of the code 3	7937 to 7959	C.D. of the code 31
1025 to 1047	C.D. of the code 4	8193 to 8215	C.D. of the code 32
1281 to 1303	C.D. of the code 5	8449 to 8471	C.D. of the code 33
1537 to 1559	C.D. of the code 6	8705 to 8727	C.D. of the code 34
1793 to 1815	C.D. of the code 7	8961 to 8983	C.D. of the code 35
2049 to 2071	C.D. of the code 8	9217 to 9239	C.D. of the code 36
2305 to 2327	C.D. of the code 9	9473 to 9495	C.D. of the code 37
2561 to 2583	C.D. of the code 10	9729 to 9751	C.D. of the code 38
2817 to 2839	C.D. of the code 11	9985 to 10007	C.D. of the code 39
3073 to 3095	C.D. of the code 12	10241 to 10263	C.D. of the code 40
3329 to 3351	C.D. of the code 13	10497 to 10519	C.D. of the code 41
3585 to 3607	C.D. of the code 14	10753 to 10775	C.D. of the code 42
3841 to 3863	C.D. of the code 15	11009 to 11031	C.D. of the code 43
4097 to 4119	C.D. of the code 16	11265 to 11287	C.D. of the code 44
4353 to 4375	C.D. of the code 17	11521 to 11543	C.D. of the code 45
4609 to 4631	C.D. of the code 18	11777 to 11799	C.D. of the code 46
4865 to 4887	C.D. of the code 19	12033 to 12055	C.D. of the code 47
5121 to 5143	C.D. of the code 20	12289 to 12311	C.D. of the code 48
5377 to 5399	C.D. of the code 21	12545 to 12567	C.D. of the code 49
5633 to 5655	C.D. of the code 22	12801 to 12823	C.D. of the code 50
5889 to 5911	C.D. of the code 23	13057 to 13079	C.D. of the code 51
6145 to 6167	C.D. of the code 24	13313 to 13335	C.D. of the code 52
6401 to 6423	C.D. of the code 25	13569 to 13591	C.D. of the code 53
6657 to 6679	C.D. of the code 26	13825 to 13847	C.D. of the code 54
6913 to 6935	C.D. of the code 27	14081 to 14103	C.D. of the code 55

Holding Register (Reference No.=4) To write comparison data		Holding Register (Reference No.=4) To write comparison data	
Address	Description	Address	Description
14337 to 14359	C.D. of the code 56	20225 to 20247	C.D. of the code 79
14593 to 14615	C.D. of the code 57	20481 to 20503	C.D. of the code 80
14849 to 14871	C.D. of the code 58	20737 to 20759	C.D. of the code 81
15105 to 15127	C.D. of the code 59	20993 to 21015	C.D. of the code 82
15361 to 15383	C.D. of the code 60	21249 to 21271	C.D. of the code 83
15617 to 15639	C.D. of the code 61	21505 to 21527	C.D. of the code 84
15873 to 15895	C.D. of the code 62	21761 to 21783	C.D. of the code 85
16129 to 16151	C.D. of the code 63	22017 to 22039	C.D. of the code 86
16385 to 16407	C.D. of the code 64	22273 to 22295	C.D. of the code 87
16641 to 16663	C.D. of the code 65	22529 to 22551	C.D. of the code 88
16897 to 16919	C.D. of the code 66	22785 to 22807	C.D. of the code 89
17153 to 17175	C.D. of the code 67	23041 to 23063	C.D. of the code 90
17409 to 17431	C.D. of the code 68	23297 to 23319	C.D. of the code 91
17665 to 17687	C.D. of the code 69	23553 to 23575	C.D. of the code 92
17921 to 17943	C.D. of the code 70	23809 to 23831	C.D. of the code 93
18177 to 18199	C.D. of the code 71	24065 to 24087	C.D. of the code 94
18433 to 18455	C.D. of the code 72	24321 to 24343	C.D. of the code 95
18689 to 18711	C.D. of the code 73	24577 to 24599	C.D. of the code 96
18945 to 18967	C.D. of the code 74	24833 to 24855	C.D. of the code 97
19201 to 19223	C.D. of the code 75	25089 to 25111	C.D. of the code 98
19457 to 19479	C.D. of the code 76	25345 to 25367	C.D. of the code 99
19713 to 19735	C.D. of the code 77	28673	Recall a code
19969 to 19991	C.D. of the code 78		

C.D.: Comparison data



9.4. Built-in Current Loop Output

- The interface can be used to connect a printer or external monitor.

Specifications

Transmission system	EIA RS-232C, Asynchronous, bi-directional, half-duplex
Current	1 = 20mA, 0 = 0 mA, external DC current source
Data length	7 bits
Start bit	1 bit
Parity bit	Even
Stop bits	1 bit
Baud rate	600 bps, 1200 bps, 2400 bps
Code	ASCII code

9.4.1. Connection

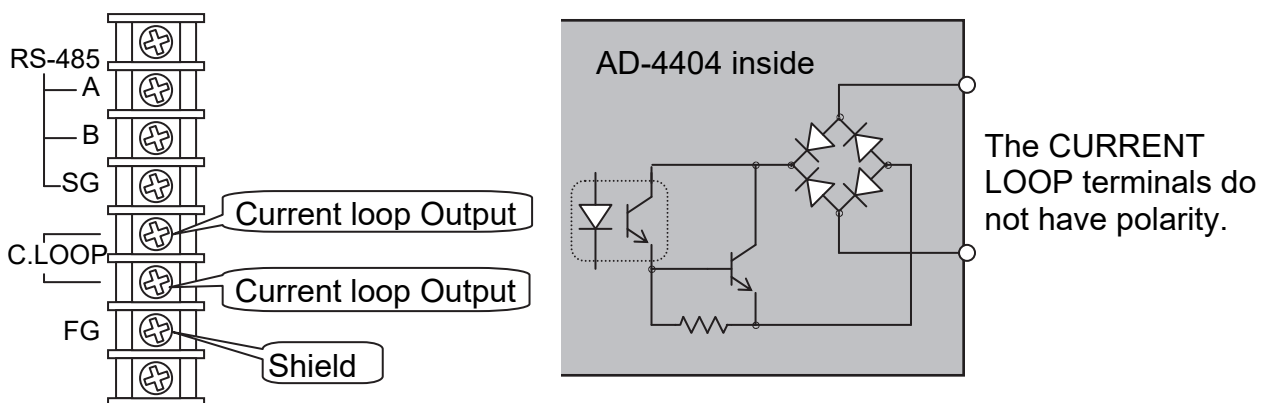

- The current loop output has no polarity.
- Use an external DC current source.
- Connect the FG terminal when using a shielded cable.

9.4.2. Communication Modes

- There are six following.

Stream Mode

The data is output on each display update. If the data can not be output completely due to a slow baud rate, the data is output at the next update.

Auto Print Mode

The comparison result is printed automatically.

Manual Print Mode

When the preset print key is pressed or terminal is connected, data is output.

9.4.3. Data Format

- The format is the same as A&D format of the built-in RS-485.

9.4.4. Settings of Parameters for Current Loop

- Refer to the "11. Parameter List" of the function list.
[Function] - [Set function] - [Serial] - [C.loop] - [59 F-01] to [59 F-08]

9.4.5. Print Format (Process Print)

- This mode is the function to print code data with a printer connected to the indicator.
- Set dump print mode in the printer.
- There are six kinds of process print at [EL F- 7].

Concerning Parameters

[EL F- 7] Process Print

[0] Not printed

[1] Mode 1 22 characters in a row and CR LF can be output.
Data is printed in two lines. Name is 12 characters.
It can be used for general printer, for "24 characters in a line" for the AD-8118C or other A&D printer.

[2] Mode 2 Mode 2 is the same as mode 1 and can print each parameter of a code.

[3] Mode 3 Data is printed in a line. Name is 9 characters.
It can be used for the AD-8118C or other A&D printer.

[4] Mode 4 Mode 4 is the same as mode 3 and can print each parameter of a code.

[5] Mode 5 It can be used with "16 characters in a line" of A&D printer or for AD-8127.

[6] Mode 6 Mode 6 is the same as mode 5 and can print each parameter of a code.

[7] Mode 7 Mode 7 can print each parameter of a code and print the total weight.

[Function] - [Set function] - [Serial] - [C.loop] - [EL F- 7]

[CL F- 2] Communication mode

[2] Auto Print

When the target count is up with auto print, data is printed automatically.

[Function] - [Set function] - [Serial] - [C.loop]

[CL F- 5] Parity check

Select even or odd to adapt to the printer.

[Function] - [Set function] - [Serial] - [C.loop]

Mode 2 only Short name is used. Mode 4 only

Mode1, 2				Mode3, 4			
Code	35	Coffee	C _R L _F	Code	35	Coffee	C _R L _F
#	1	OK	C _R L _F	#	1	OK	10.012 kg
		10.012	kg _{C_RL_F}	#	2	LoLo	8.006 kg
#	2	LoLo	C _R L _F	#	3	Lo	9.502 kg
		8.006	kg _{C_RL_F}	#	4	Fo	10.010 kg
#	3	Lo	C _R L _F	#	5	Cr	20.106 kg
		9.502	kg _{C_RL_F}	#	126	OK	10.002 kg
#	4	FMD	C _R L _F				
		10.010	kg _{C_RL_F}	C _R L _F	Tot#	12345678	C _R L _F
#	5	Crush	C _R L _F	NG#	12345678	C _R L _F	
		20.106	kg _{C_RL_F}	LoLo#	12345678	C _R L _F	
#	126	OK	C _R L _F	Lo#	12345678	C _R L _F	
		10.002	kg _{C_RL_F}	OK#	12345678	C _R L _F	
C _R L _F	Tot#	12345678	C _R L _F	Hi#	12345678	C _R L _F	
	NG#	12345678	C _R L _F	HiHi#	12345678	C _R L _F	
	LoLo#	12345678	C _R L _F	FMD#	12345678	C _R L _F	
	Lo#	12345678	C _R L _F	Dup#	12345678	C _R L _F	
	OK#	12345678	C _R L _F	Crush#	12345678	C _R L _F	
	Hi#	12345678	C _R L _F	Max	123456.789	kg _{C_RL_F}	
	HiHi#	12345678	C _R L _F	Min	123456.789	kg _{C_RL_F}	
	FMD#	12345678	C _R L _F	Ave	123456.789	kg _{C_RL_F}	
	Dup#	12345678	C _R L _F	STD	123456.789	kg _{C_RL_F}	
	Crush#	12345678	C _R L _F	STDP	123456.789	kg _{C_RL_F}	
	Max	123456.789	kg _{C_RL_F}	Tot	123456.789	kg _{C_RL_F}	
	Min	123456.789	kg _{C_RL_F}	C _R L _F			
	Ave	123456.789	kg _{C_RL_F}				
	STD	123456.789	kg _{C_RL_F}				
	STDP	123456.789	kg _{C_RL_F}				
	Tot	123456.789	kg _{C_RL_F}				
C _R L _F							

Standard deviation σ_{n-1} : STD
 Population standard deviation σ_n : STDP

Mode5, 6

Mode 6 only

C35 Brazil	
# 1 OK	1234.56 kg
# 2 LoLo	1234.56 kg
# 3 Lo	1234.56 kg
# 4 Fo	1234.56 kg
# 5 Cr	1234.56 kg
<hr/>	
# 126 OK	1234.56 kg
<hr/>	
Tot#	12345678
NG#	12345678
LoLo#	12345678
Lo#	12345678
OK#	12345678
Hi#	12345678
HiHi#	12345678
FMD#	12345678
Dup#	12345678
Crush#	12345678
Max#	1234.56 kg
Min#	1234.56 kg
Ave	1234.56 kg
STV	1234.56 kg
STDP	1234.56 kg
Tot	12345.67 kg

Mode7

Short name is used.

C35 Brazil		C _R L _F
# 1 OK	10.012	C _R L _F
# 2 LoLo	18.018	C _R L _F
# 3 Lo	27.520	C _R L _F
# 4 Fo	37.530	C _R L _F
# 5 Cr	57.646	C _R L _F
<hr/>		
# 1234 OK	1342.508	C _R L _F
<hr/>		
Tot#	12345678	C _R L _F
NG#	12345678	C _R L _F
LoLo#	12345678	C _R L _F
Lo#	12345678	C _R L _F
OK#	12345678	C _R L _F
Hi#	12345678	C _R L _F
HiHi#	12345678	C _R L _F
FMD#	12345678	C _R L _F
Dup#	12345678	C _R L _F
Crush#	12345678	C _R L _F
Max	123456.789 kg	C _R L _F
Min	123456.789 kg	C _R L _F
Ave	123456.789 kg	C _R L _F
STD	123456.789 kg	C _R L _F
STDP	123456.789 kg	C _R L _F
Tot	123456.789 kg	C _R L _F

Standard deviation σ_{n-1} : STD
 Population standard deviation σ_n : STDP

9.4.6. Time Stamp

- If the printer has the function to print time and date, the time stamp can be appended to the printed data. Example: printer AD-8118C, AD-8127.
- The indicator can send the following commands.
 - Date command

E	D
C	

 ASCII code: 1B, 44
 - Time command

E	T
C	

 ASCII code: 1B, 54
- The time stamp can be appended to total print with Print for data and time [LL F- B].

Concerning Parameters

- [LL F- B] Print for data and time
 - [0] Not printed
 - [1] Date before total
 - [2] Time before total
 - [3] Date & time before total
 - [4] Date after total
 - [5] Time after total
 - [6] Data & time after total
- [Function] - [Set function] - [Serial] - [C.loop] - [LL F- B]



9.5. BCD Output of Option OP-01

- The interface can be used to connect a printer or external monitor.

Specifications

Output circuit	Open collector transistor
Output voltage	40 V DC max.
Output saturation voltage	0.8 V at 25 mA
Input control	Contact to common
Input open voltage	5 V DC $\pm 5\%$
Input current	5 mA max.
Threshold voltage	1.5 V max.

Connection

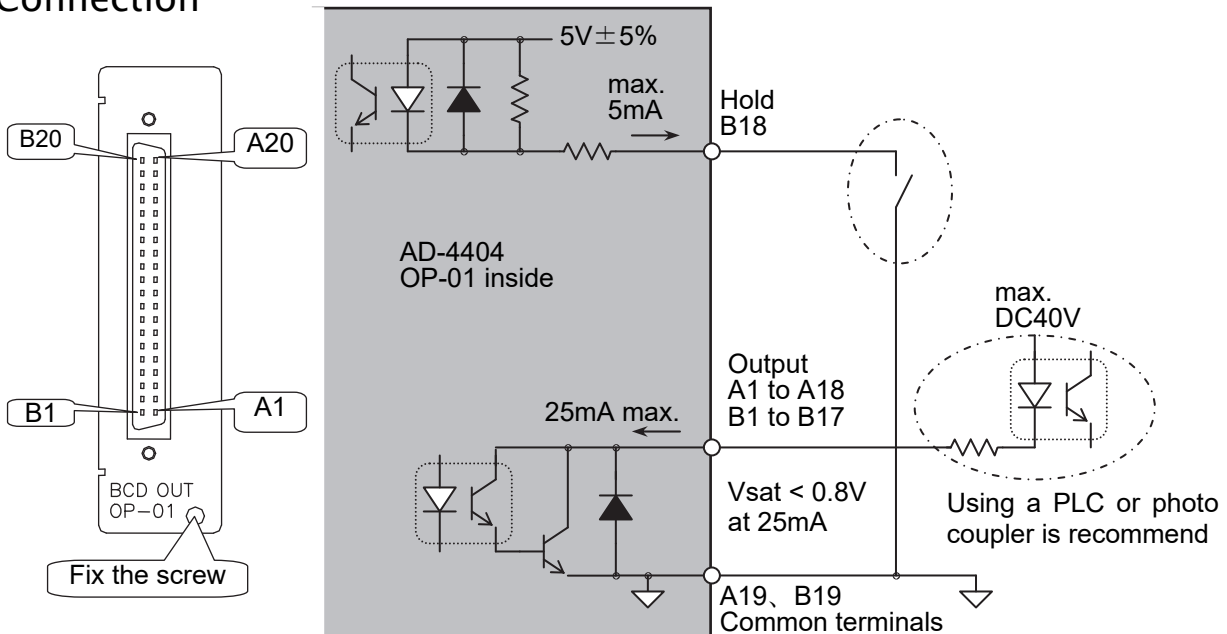

Accessories

Connector	J1:361J040-AG	1 piece
Connector cover	J1:360C040-B	1 piece

Concerning Parameters

- [01 F- 1] Output mode
[Function] - [Set function] - [Option] - [OP-01[BCD]]
- [01 F- 3] Communication mode
[Function] - [Set function] - [Option] - [OP-01[BCD]]
- [01 F- 4] Output logic
[Function] - [Set function] - [Option] - [OP-01[BCD]]

Terminals

When weighing display [1], gross display [2], net display [3] or tare display [4] of Output mode [0 IF- 1] is output, the function of the terminals are as follows:

A1	1	B1	2	Unit	Unit 1	Unit 2
A2	4	B2	8	blank	0	0
A3	10	B3	20	kg	0	0
A4	40	B4	80	t	0	1
A5	100	B5	200	g	1	1
A6	400	B6	800			
A7	1,000	B7	2,000			
A8	4,000	B8	8,000			
A9	10,000	B9	80,000			
A10	40,000	B10	80,000			
A11	100,000	B11	200,000			
A12	400,000	B12	800,000			
A13	Over	B13	Positive polarity			
A14	Stable	B14	Net			
A15	Decimal point 0.0	B15	Decimal point 0.0			
A16	Decimal point 000.0	B16	Decimal point 000.0			
A17	Unit 1	B17	Unit 2			
A18	Strobe	B18	Hold input			
A19	Common ground	B19	Common ground			
A20	Frame ground	B20	Frame ground			

When total weight [5] and total count [6, 7, 8] of Output mode [0 IF- 1] are output, the function of the terminals are as follows:

A1	1	B1	2
A2	4	B2	8
A3	10	B3	20
A4	40	B4	80
A5	100	B5	200
A6	400	B6	800
A7	1,000	B7	2,000
A8	4,000	B8	8,000
A9	10,000	B9	80,000
A10	40,000	B10	80,000
A11	100,000	B11	200,000
A12	400,000	B12	800,000
A13	1,000,000	B13	2,000,000
A14	4,000,000	B14	8,000,000
A15	10,000,000	B15	20,000,000
A16	40,000,000	B16	80,000,000
A17	Over	B17	Positive polarity
A18	Strobe	B18	Hold input
A19	Common ground	B19	Common ground
A20	Frame ground	B20	Frame ground

When alarm number and error number of Output mode [0 IF- 1] [10] are output, the function of the terminals are as follows:

A1	Sequence error number	1	B1	Sequence error number	2
A2		4	B2		8
A3		Error	B3		
A4			B4		
A5	Zero error number	1	B5	Zero error number	2
A6		4	B6		8
A7		Error	B7		
A8			B8		
A9	Alarm 1 number	1	B9	Alarm 1 number	2
A10		4	B10		8
A11		Error	B11		
A12			B12		
A13	Alarm 2 number	1	B13	Alarm 2 number	2
A14		4	B14		8
A15		Error	B15		
A16			B16		
A17			B17		
A18	Print strobe		B18	Hold input	
A19	Common ground		B19	Common ground	
A20	Frame ground		B20	Frame ground	

Communication Modes

- There are the following modes. The mode can be selected at Communication mode [0 IF- 3].

Stream Mode of [0 IF- 3] [1]

The data is output at every display update. If the data can not be output completely due to a slow baud rate, the data is output at the next update.

Auto Print Mode of [0 IF- 3] [2]

The data is printed at judgement automatically.

Manual Print Mode of [0 IF- 3] [3]

When the preset print key is pressed or terminal is connected, data is output.

Jet Steam Mode of [0 IF- 3] [4]

The weighing data and state are output 100 time/s. The data is the gross or net value. The format is the same as command RGRS or RNET.

Set baud rate to 38400 bps.

Set the baud rate to 38400 bps. If another baud rate is used, mis-sampling may occur.

Output data is repeated according to the number of Sampling frequency divider [0EF-3].

Timing Chart

When **normal output** [0 1F - 3] ≠ 4 is used

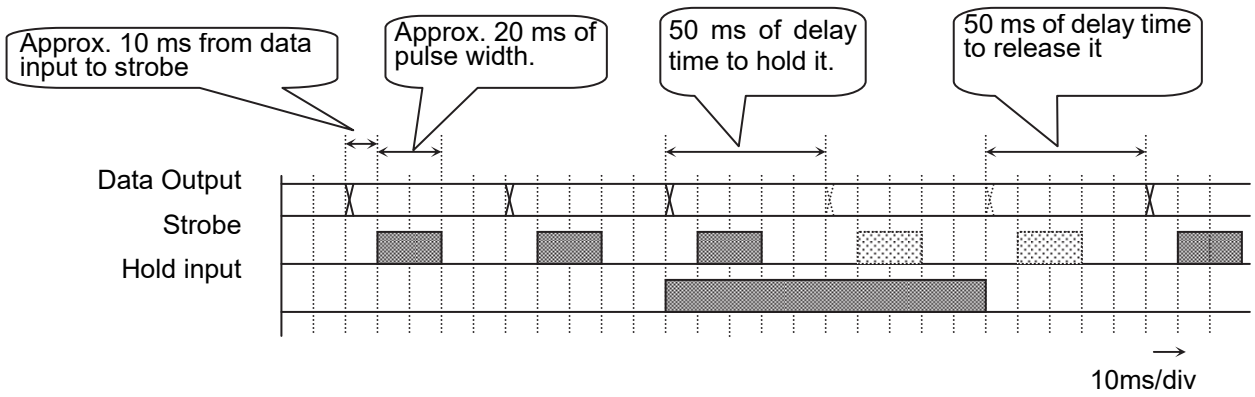

When **jet steam mode** output [0 1F - 3] = 4 is used

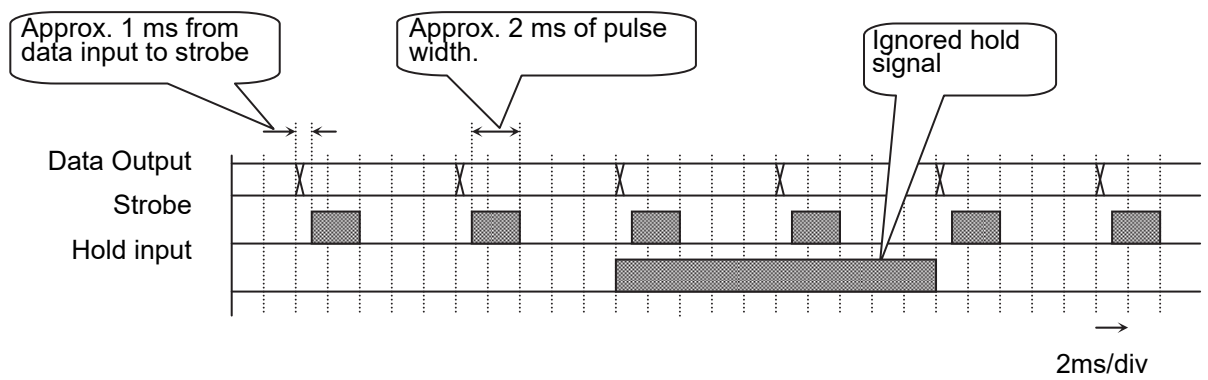



9.6. Relay Output of Option OP-02

- This option can output the same function as the control output to relays.

Specifications

Rated load	250 V AC, 3 A 30 V DC, 3 A
Current at common terminal	Max. 10A DC
Minimum load	100 mV 100 μA
Life	20,000,000 times or more at no load 100,000 times or more at rated load

Connection

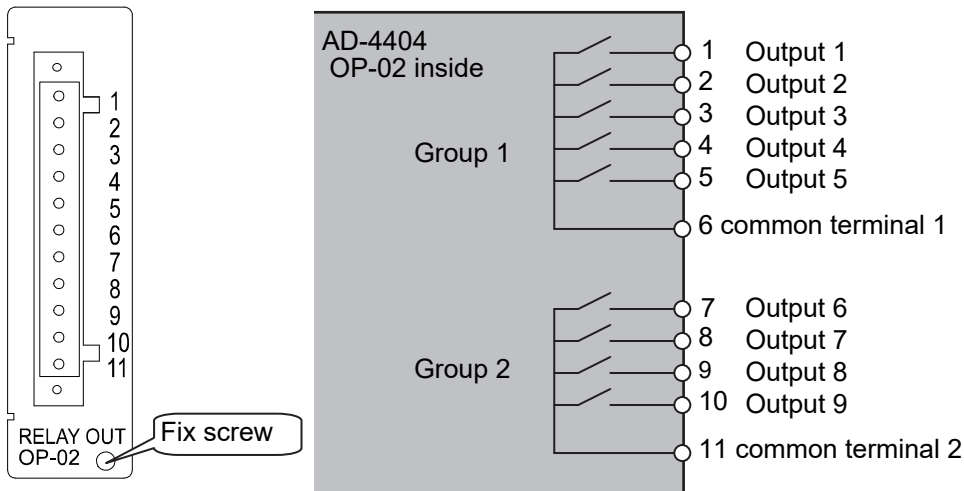

Caution

- Use noise reduction parts to avoid noise. Example: Varistor, surge diode, snubber circuit.

Accessories

Relay connector TM:MSTB11STF 1 piece

Terminals and Concerning Parameters

Terminal	Function Address	Function
Output 1	02 F- 1	The function of the relay can be specified with a function number that is the same as those of the control output. Refer to "11. Function List" concerning the function. [Function] - [Set function] - [Option] - [OP-02[Relay]]
Output 2	02 F- 2	
Output 3	02 F- 3	
Output 4	02 F- 4	
Output 5	02 F- 5	
Output 6	02 F- 6	
Output 7	02 F- 7	
Output 8	02 F- 8	
Output 9	02 F- 9	
Output 10	02 F- 10	



9.7. RS-422/485 Interface of Option OP-03

- The RS-422/485 interface can use commands to control the indicator. The interface can read weighing data or parameters or store parameters to the indicator.
- The interface can connect a maximum of 32 units and a personal computer using a communication cable.
- The unit is specified by an address appended to the command.
- RS-485 can use 2-wire or 4-wire.
- The command and format are the same as the built-in RS-485.
- When installing OP-03 and OP-04 at once, two options can be installed at maximum.

Specifications

Transmission system	EIA RS-422 / 485, Asynchronous, bi-directional, half-duplex
Data length	7 bits or 8 bits
Start bit	1 bit
Parity bit	Odd, Even, not used
Stop bits	1 bit, 2 bits
Baud rate	600 bps, 1200 bps, 2400 bps, 4800 bps, 9600 bps, 19200 bps, 38400 bps(Jet stream mode)
Line	RS-422: 4 wires RS-485: 2 wires or 4 wires
Connection	Max. 32 units
Character code	ASCII code
Terminator	CR, CR LF

Connection

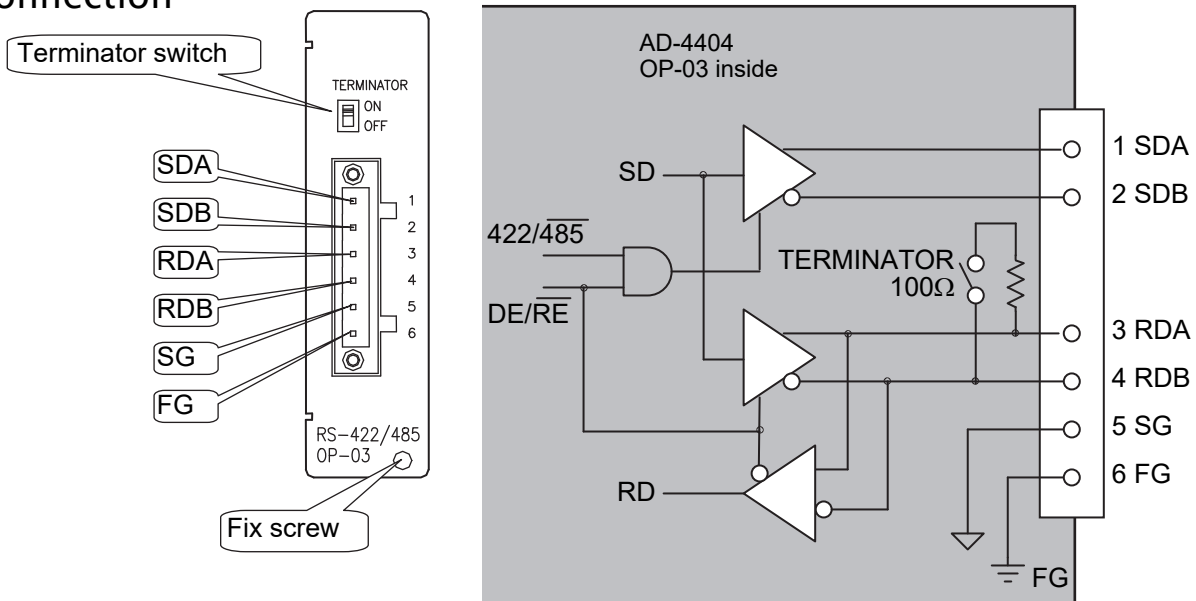

Accessories

Connector	TM:MSTB06STF	1 piece
-----------	--------------	---------

RS-422 Connections

Settings RS-422 [03 F-11] [1]
 Address Number 0 [03 F-8] [0].

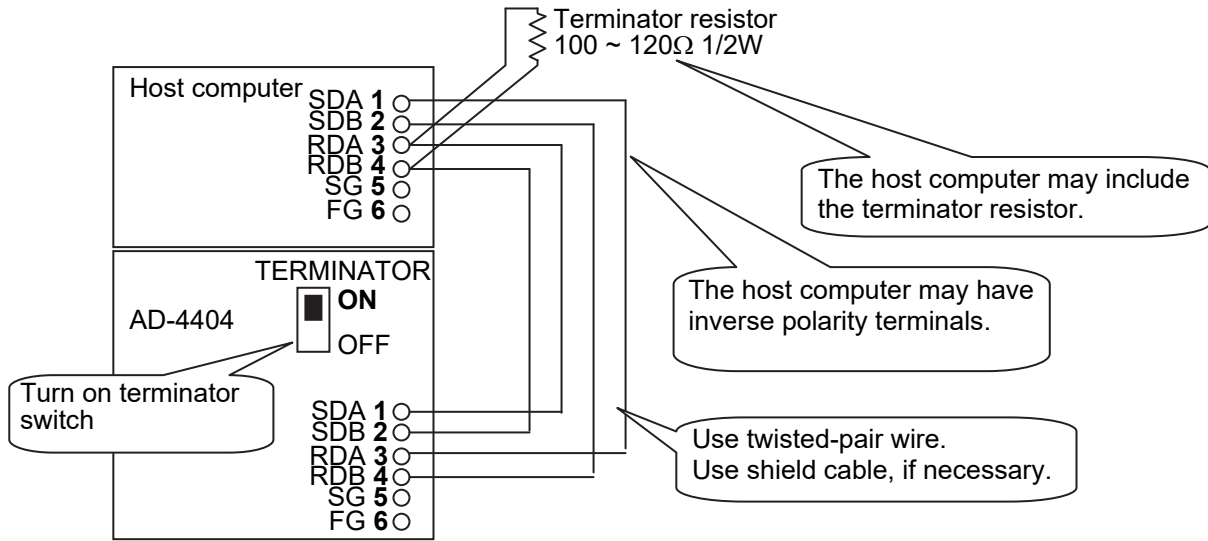

RS-485 4 Wire Connections for Command Mode

Settings RS-485 [03 F-11] [1]
 Address Number [03 F-8] [without 0].

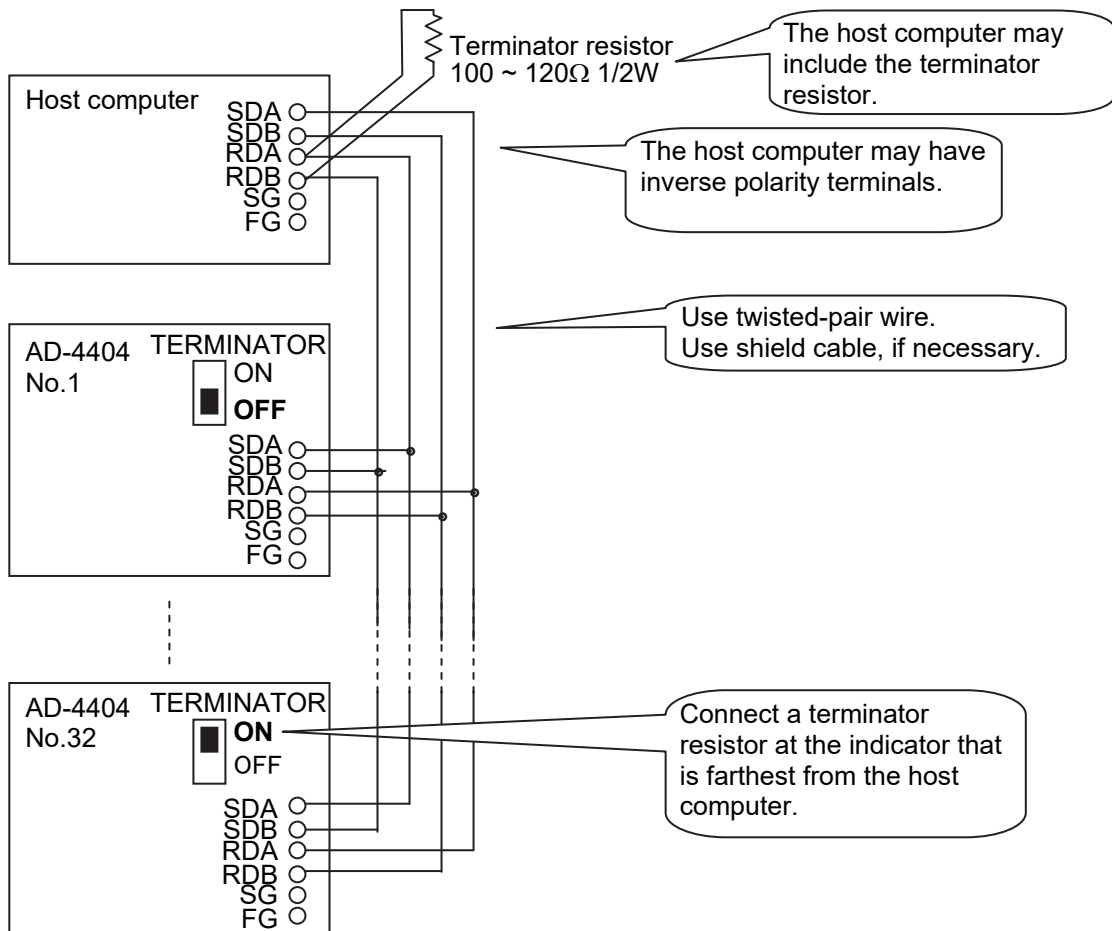

Caution

- This connection can be used only with command mode.

RS-485 2 Wire Connections for Command Mode

Settings RS-485

[03 F-11] [2]

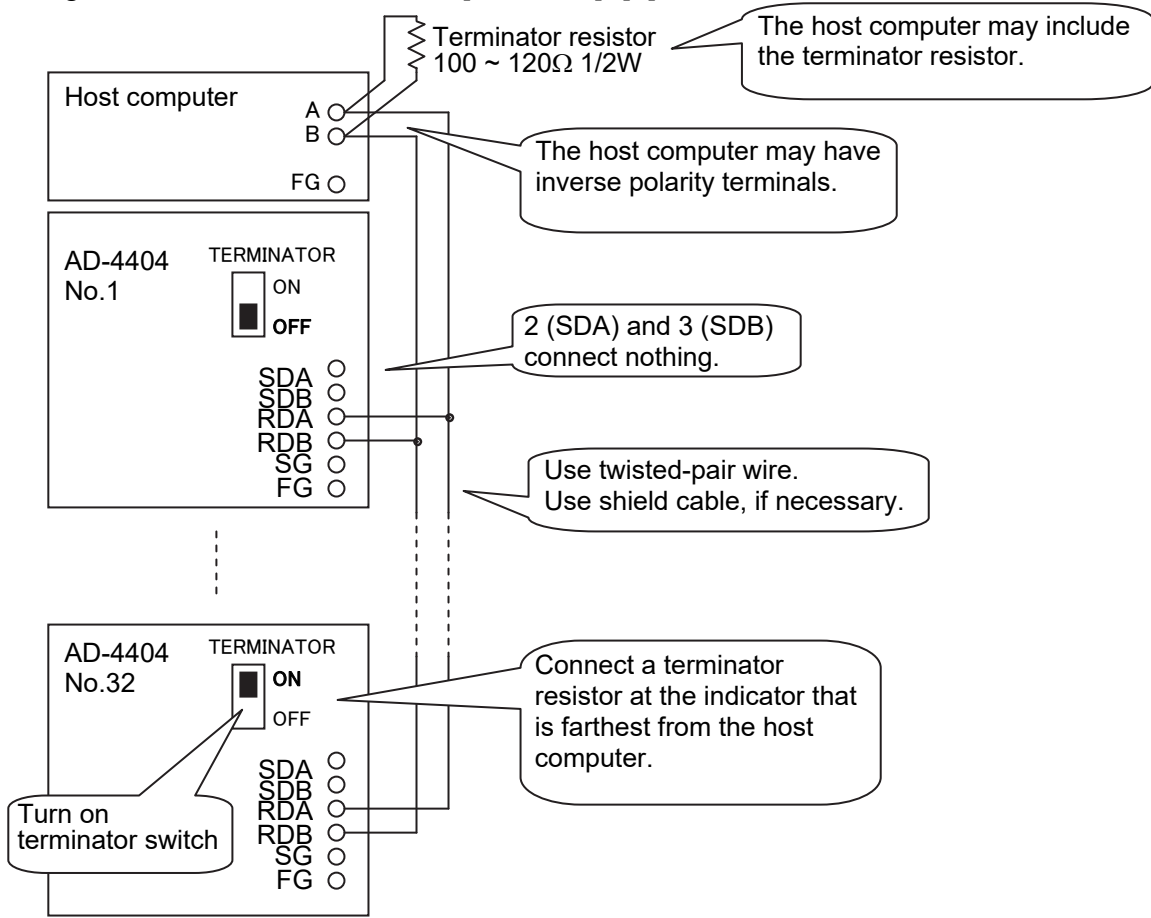

Caution

- This connection can be used only with command mode.

Settings of Parameters

Refer to "11. Function List".

Timing Chart

- Keep the delay time above 4 ms between the last response and the next command.
- Set response time (t_r). $[03 F-9] < t_r < [03 F-9] + 50 \text{ ms}$
- Use a long delay time, when there is noise.
- Use 4 ms or more from the output finish to receiving the next command
- Hi-Z: Hi impedance

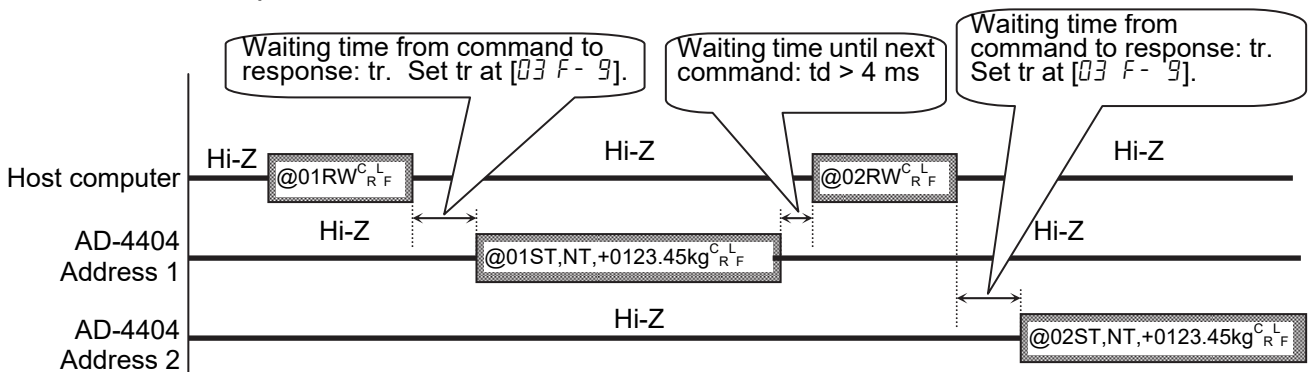



9.8. RS-232C Interface of Option OP-04

- The RS-232C is used to connect to the DEC (modem).
- The command and parameters of RS-232C is the same as the built-in RS-485.
- When installing OP-03 and OP-04 at once, two options can be installed at maximum.

Specifications

Transmission system

EIA RS-232C,

Asynchronous, bi-directional, half-duplex

Data length

7 bits or 8 bits

Start bit

1 bit

Parity bit

Odd, Even, not used

Stop bits

1 bit, 2 bits

Baud rate

600 bps, 1200 bps, 2400 bps, 4800 bps, 9600 bps, 19200 bps

Connection

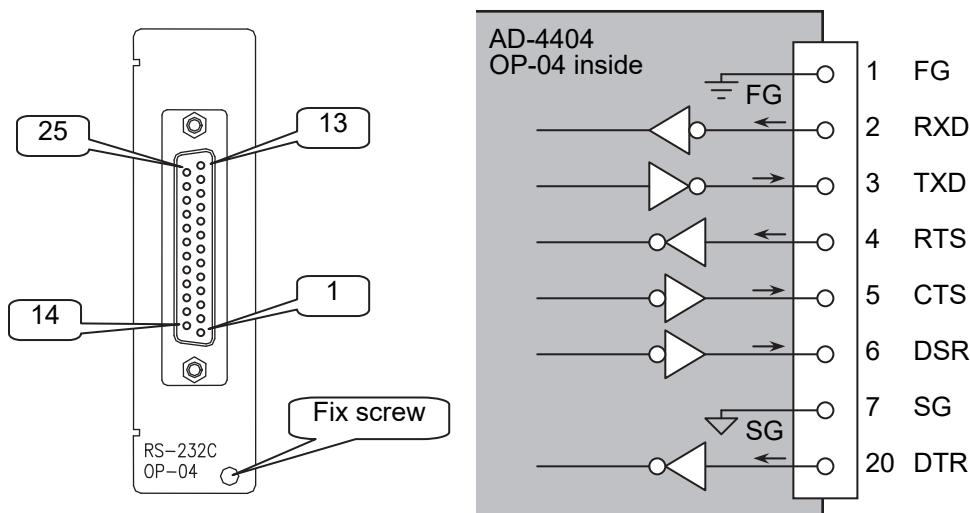

Settings of Parameters

Refer to "11. Function List".



9.9. Parallel I/O of Option OP-05

- This option can be used to extend the terminals of the control I/O.
- The function, settings, interface circuit and timing chart of the option is the same as the control I/O.
- Two OP-05 can be installed at maximum.

Specifications

Input control	Contact to common
Input open voltage	7 ~ 11 V DC
Input current	5 mA max.
Input threshold voltage	2 V max.
Output circuit	Open collector transistor
Output voltage	40 V DC max.
Output saturation voltage	1.5 V at 50 mA

Caution

Do not assign the same function to multiple input terminals and keys.

Connection and Parameters

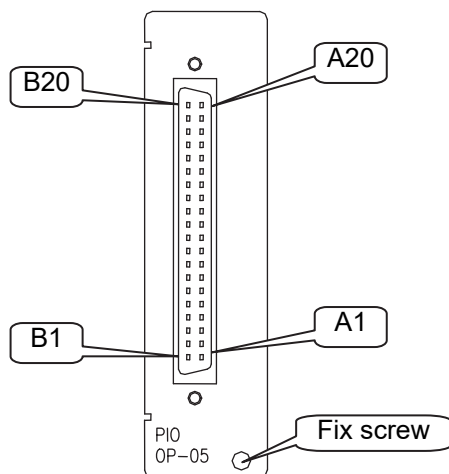

A1 to A16	Input terminal 1 to 16
A17	Input common
A18	
A19	
A20	Frame ground
B1 to B16	Output terminal 1 to 16
B17	Output common
B18	
B19	
B20	Frame ground

	Terminal	Function Address	Function
Input	A 1	05 F- 1	The function of the input and output can be specified with a function number that is the same as the control I/O. Refer to "11. Function List" concerning the function. [Function] - [Set function] - [Option] - [OP-05[I/O]]
	
Output	A 16	05 F- 16	
	B 1	05 F- 17	
	
	B 16	05 F- 32	

Accessories

Connector	J1:361J040-AG	1 piece
Connector cover	J1:361C040-B	1 piece

Circuit

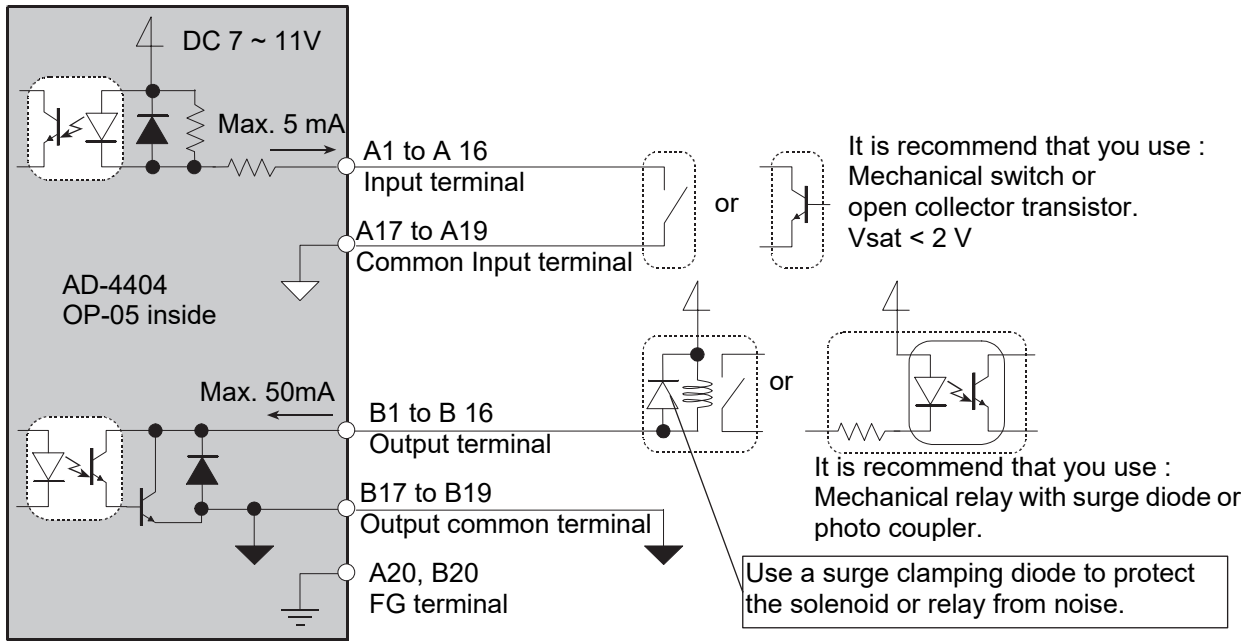



9.10. Analog Output of Option OP-07

- This option outputs DC current that is proportional to the display value.
Factory adjusted to 4 mA output at zero display and 20 mA output at full scale.

Specifications

Analog output	Contact to ground
Output voltage	11 V DC min.
Adaptable resistance	0 Ω ~ 500 Ω
Update ratio	100 times per second with Sampling frequency divider [GF-3]
Zero temperature coefficient	±150 ppm/°C max.
Span temperature coefficient	±150 ppm/°C max.
Non-linearity	0.1% max.
Resolution	Smaller value of either 1/40000 or resolution of display

Connection

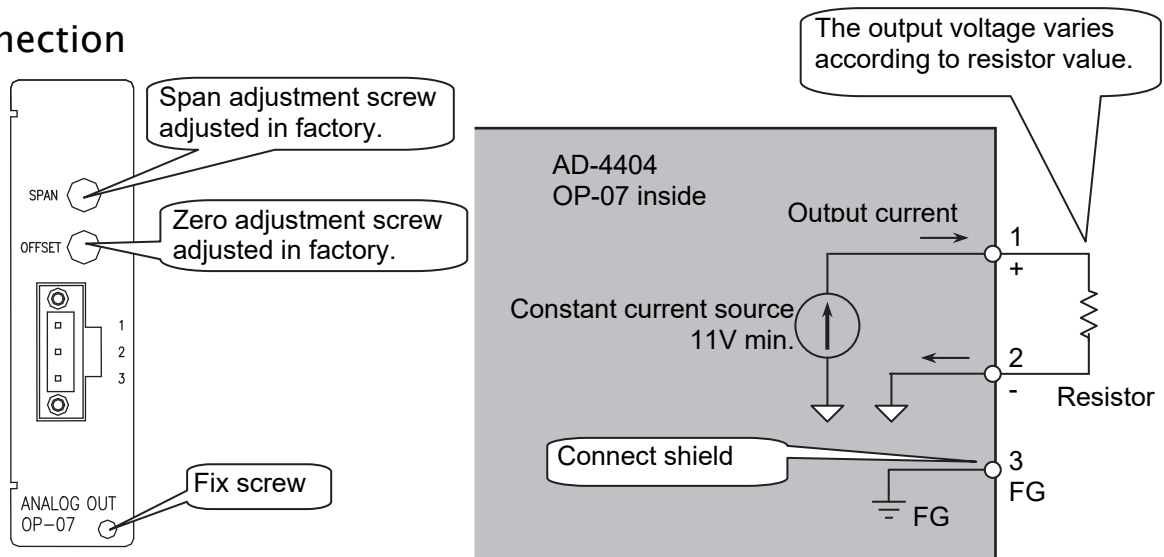

Settings of Parameters

Refer to "11. Function List".

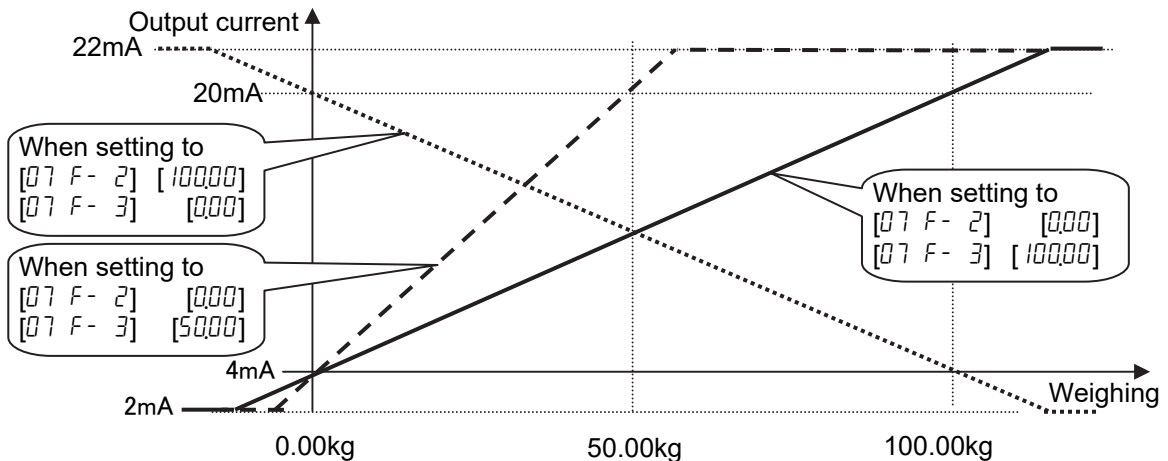



10. Maintenance (Monitor and Test)

10.1.1. Basic Operation

To enter the maintenance function	Press and hold the ENTER key and press the ↵ key in the weighing mode. Select the menu Check using the ↵ key and the ENTER key..
To select an address of the parameter	Press the ↵ , SHIFT + ↵ , ENTER , ESC keys.
To change the parameter	Press the ↵ , SHIFT + ↵ , Alphanumerical , ENTER , ESC keys.
To exit the mode (To return to the weighing mode)	Press the ESC key.



10.2. Monitor Mode

- The monitor mode is used to check the indicator during the weighing sequence.

10.2.1. Monitoring the Control I/O Function

- Used to monitor the status of the I/O terminals. If the rate is faster than the **Display refresh rate [GEnF-01]** it can not be displayed.
0: The inactive status to open the open collector of the output.
1: The active status to short the open collector of the output.

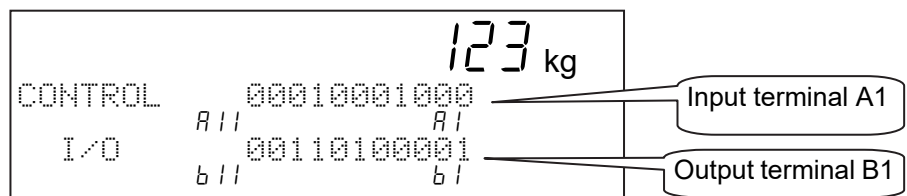

10.2.2. Monitoring Built-in RS-485 Interface

- The current communication data is displayed. Output is according to Communication mode [**r5 F-02**].
← : CR
↓ : LF

Parity error: *P*
Framing error: *F*

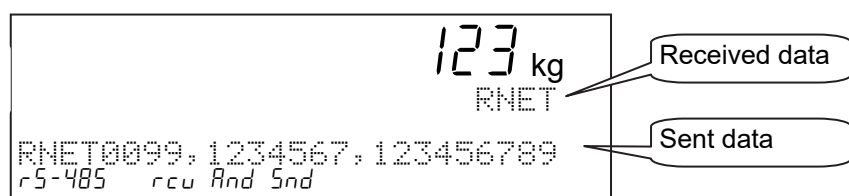

10.2.3. Monitoring Built-in Current Loop Output

- The current communication data is displayed. Output is according to Communication mode [CL F-02].

← : CR
↓ : LF

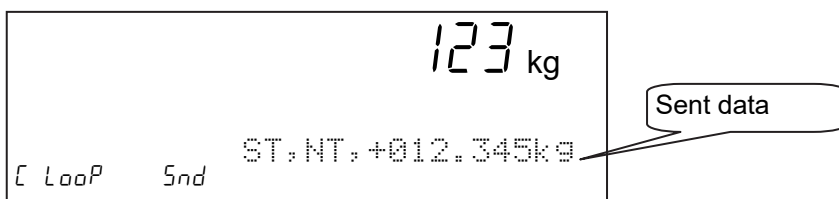

10.2.4. Monitoring A/D Converter

- The current A/D converter data is displayed.

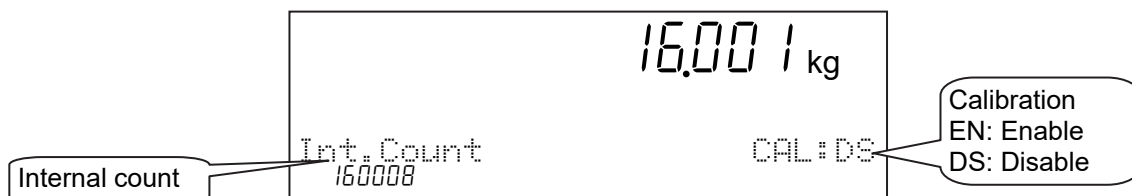

10.2.5. Monitoring BCD Output of OP-01

- The current BCD output data is displayed.
 - 0: The inactive status to open the open collector of the output.
 - 1: The active status to short the open collector of the output.
- The print strobe is displayed in the original logic level.

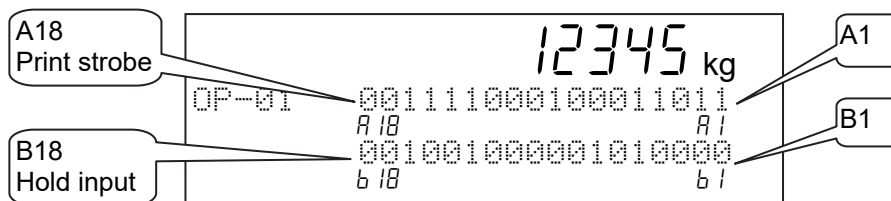

10.2.6. Monitoring Relay Output of OP-02

- The status of the current relay outputs is displayed. If the rate is faster than the Display refresh rate [DENF-01] it can not be displayed.
- 0: The inactive status to open the relay.
- 1: The active status to short the relay.

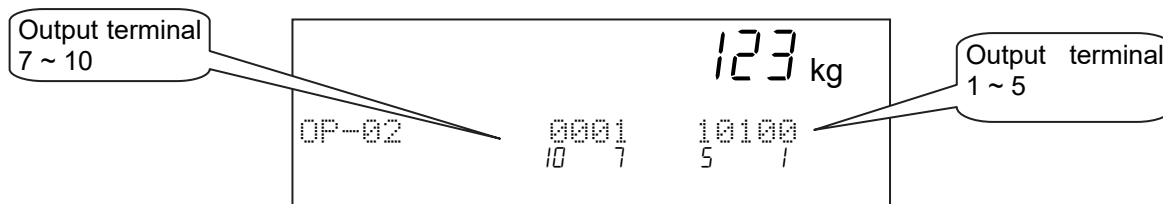

10.2.7. Monitoring RS-422/485 Interface of OP-03

- The current communication data is displayed. Output is according to Communication mode [03 F-02].

← : CR

↓ : LF

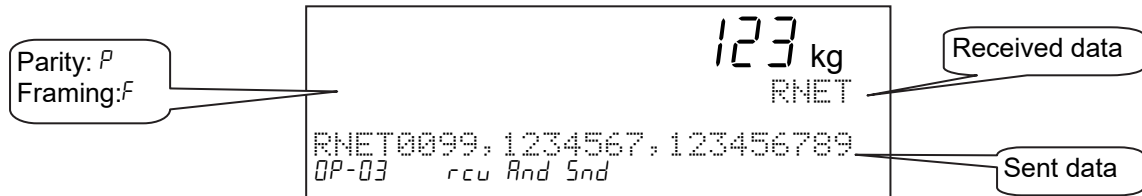

10.2.8. Monitoring RS-232C Interface of OP-04

- The current communication data is displayed. Output is according to Communication mode [04 F-02].

← : CR

↓ : LF

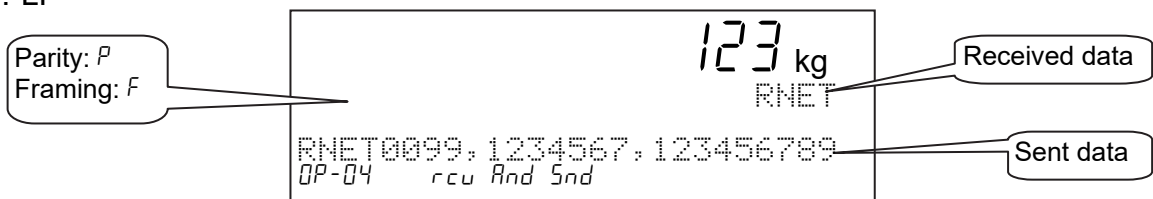

10.2.9. Monitoring Parallel I/O of OP-05

- The status of current parallel I/O is displayed. If the rate is faster than the Display refresh rate [05 F-01] it can not be displayed.

0: The inactive status to open the open collector of the output.

1: The active status to short the open collector of the output.

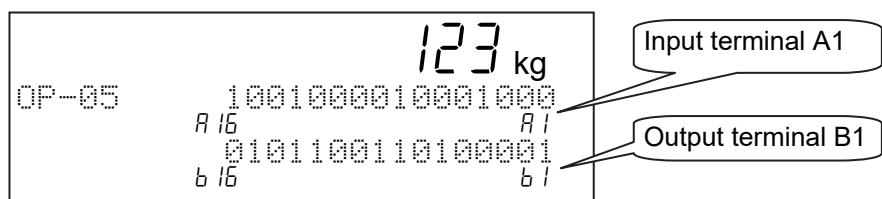

10.2.10. Monitoring Analog Output of OP-07

- The current communication data is displayed.

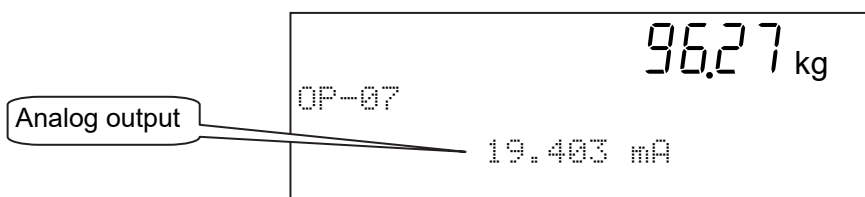



10.3. Test Mode

- The test mode is used to check the indicator and weighing system with a test signal.
- When the test mode is used, the weighing sequence is stopped.

Caution

- Turn off the peripherals before test. The test mode outputs a test signal. Therefore, the devices connected to system are influenced and it may cause mis-operation.

10.3.1. Testing Control I/O Function

- Terminal displays the current input data.
- One of terminal B turns on every one second and in order. The active terminal displays "1".

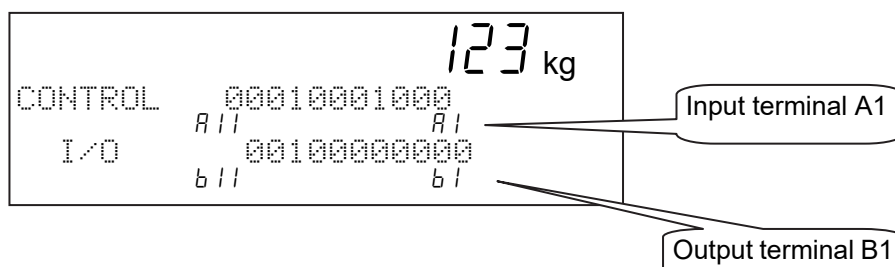

10.3.2. Testing Built-in RS-485 Interface

- Each time to press the **ENTER** key, the test data "ST,GS,+0000000kg CR LF" is output.
- The received data is displayed, when data is output.
← : CR
↓ : LF

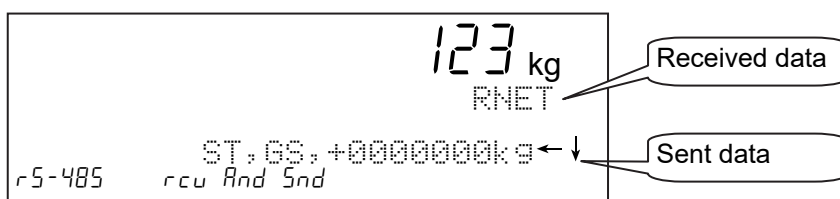

10.3.3. Testing Built-in Current Loop Output

- Each time to press the **ENTER** key, the test data "ST,GS,+0000000kg CR LF" is output.
- The received data is displayed, when data is output.
← : CR
↓ : LF

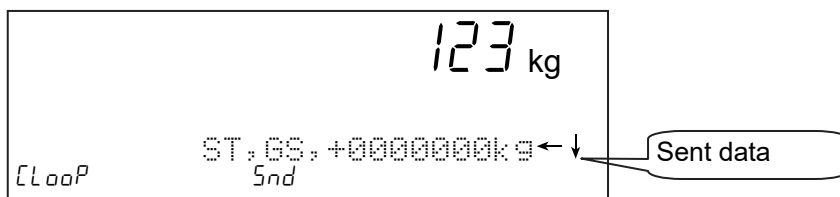

10.3.4. Testing A/D Converter

- The A/D converter data is displayed.
- When pressing the **ENTER** key, a test voltage can be input to the A/D converter.

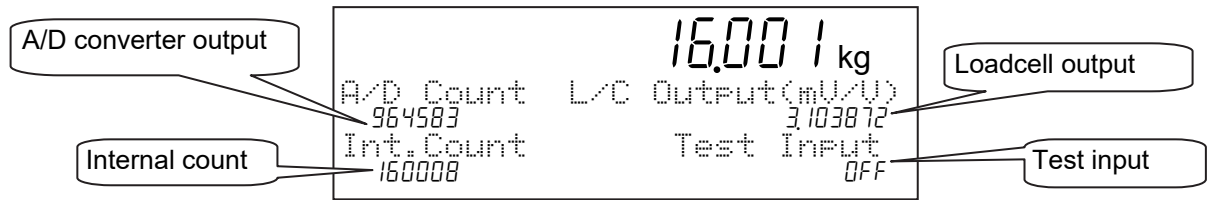

10.3.5. Testing BCD Output of OP-01

- One of terminal A and B alternately turns on every one second and in order. The active terminal displays "1".

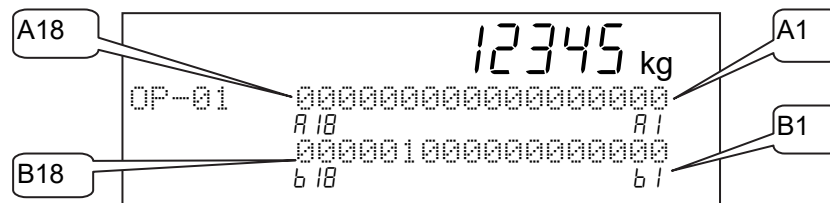

10.3.6. Testing Relay Output of OP-02

- A terminal of the relays turns on every one second and in order. The active terminal displays "1".

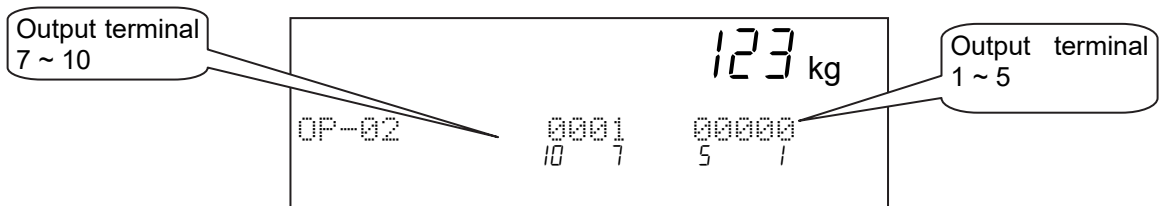

10.3.7. Testing RS-422/485 Interface of OP-03

- Each time to press the **ENTER** key, the test data "ST,GS,+0000000kg CR LF" is output.
- The received data is displayed, when data is output.

← : CR
↓ : LF

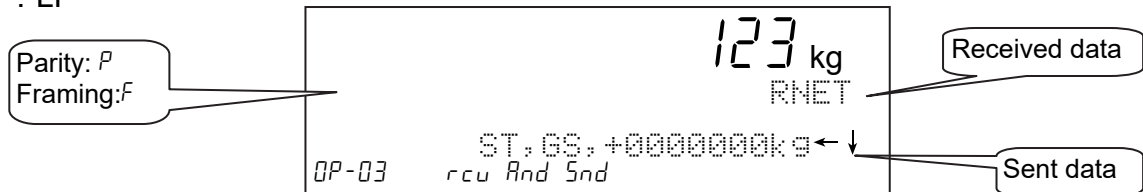

10.3.8. Testing RS-232C Interface of OP-04

- Each time to press the **ENTER** key, the test data "ST,GS,+0000000kg CR LF" is output.
 - The received data is displayed, when data is output.
- ← : CR
 ↓ : LF

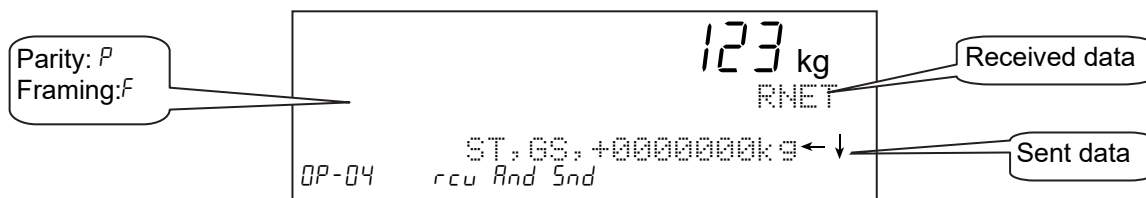

10.3.9. Testing Parallel I/O of OP-05

- Terminals display the current input data.
- One of terminal B turns on every one second and in order. The active terminal displays "1".

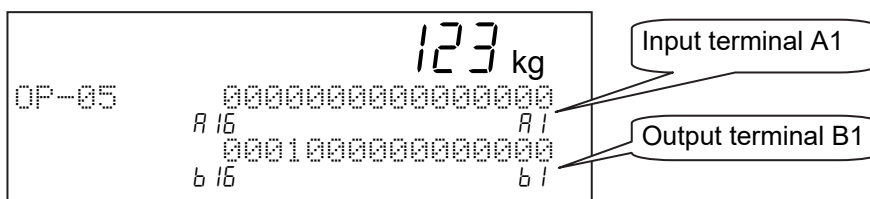

10.3.10. Testing Analog Output of OP-07

- When pressing the **1** key, the output current is increased.
- When pressing the **2** key, the output current is decreased.

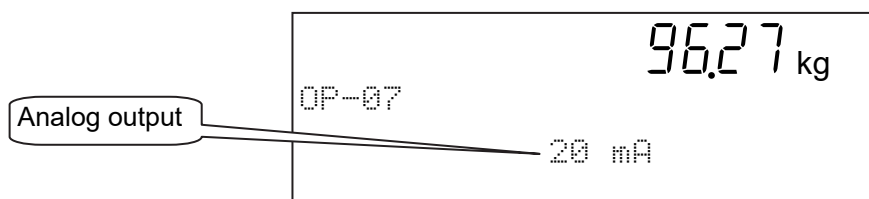



10.4. Initializing Parameters

- This function initializes the parameters stored in the indicator.
- The parameters are stored in the flash memory and backup RAM.

Caution

- **There are reset functions that require re-calibration of the indicator**
- **Note where the parameters are stored.**

Kinds of initialization mode

- The menu to initialize parameters is as follows:
 [Function] - [Set function] - [SystemMgmt] - [init]
 - ├ [RAM]
 - ├ [Code]
 - ├ [Function]
 - ├ [CAL]
 - └ [All]

Display	Kinds	Description
RAM	Initializing RAM	The backup RAM is reset. Zero point of the gross display, tare value zeroes.
Code	Initializing all codes	All parameters of all codes are reset.
Function	Initializing the function parameters	Resets parameters of the function list in flash memory.
CAL	Initializing caribration data	Calibration data is reset in flash memory. If this function is used, calibrate the indicator. #1
All	Initializing all parameters	All parameters and calibration data are reset. Recalibrate and input all parameters. #1

#1 If the switch on the A/D board set to "Disable", it can not be performed.

The Location of the Parameters and Objects of Initialization Mode

		Zero	Tare	Code without total	All code	Function list	Calibration data
Location	Backup RAM	○	○	○	○ #2		
	Flash memory			○ #1		○	○
Kinds	RAM	○	○				
	Code			○	○		
	Function					○	
	CAL						○
	All	○	○	○	○	○	○

#1 Code data can be stored into flash memory. Refer to " 8.26. Memory Backup"

#2 Total data is always stored in backup RAM.

Procedure

Caution

- Do not initialize parameters while in operation. Cut off the power supply of other systems. When initializing the indicator, the output may change.
- When initializing the indicator, do not turn off the indicator before it is reset.

To enter initialization

- Step 1 Press and hold the **ENTER** key and press the **↔** key to display the menu in a weighing mode.
- Step 2 Select the menu `SystemMgmt` using the **↔** key, **ENTER** key.
Select the menu `Init` using the **↔** key, **ENTER** key.
Category address: [Function] - [Set function] - [SystemMgmt] - [init]
- Step 3 Select the initialization menu using the **↔** key, **ENTER** key.
Menu: `RAM, Code, Function, CAL` or `ALL`
- Step 4 Press `Yes` to initialize them using the **↔** key, **ENTER** key.
- Step 5 Wait for the indicator to reset.



10.5. Remote Operation

- This mode can read and write the parameters of the function list, the code data and calibration data.
- The built-in RS-485, RS-422/485 (OP-03) or RS-232C (OP-04) is used for remote operation.
- It is necessary to install the **remote setup program** in the computer or controller before use. Refer to <http://www.aandd.co.jp>
- Refer to the instruction manual for details of the program.

Caution

Do not download data during a weighing operation.

Do not turn off the indicator during down load.

Remove all connections to prevent an irregular operation.

Maintain the power supply during the remote setup operation.

Entering the Remote Operation Mode

- Step 1 Press and hold the **ENTER** key and press the **↵** key to display the menu in a weighing mode.
- Step 2 Select the menu `SystemMgmt` using the **↵** key, **ENTER** key.
Select the menu `RemoteSetup` using the **↵** key, **ENTER** key.
Category address: [Function] - [Set function] - [SystemMgmt] - [RemoteSetup]
- Step 3 Select a menu using the **↵** key, **ENTER** key.
Menu: `Data` or `Software`
- Step 4 If `Data` is selected, press `Yes` to down load the data using the **↵** key, **ENTER** key.
- Step 5 Press the **ESC** key to return to weighing mode.

Advise

The following RS-232C to RS-485 converter can be used.



11. Function List

- The function list stores parameters to control the indicator.
- The parameters are stored in an item even without power supplied.
- An item is classified by a category address, and is further classified by an item number. Refer to " 11.1.2. Outline of the Function List".
- The category address has a symbol for the 7-segments display.
- There are two kind of the function modes to operate the function list.
 - Parameter settings The mode to edit the parameter.
 - Referring parameters The mode to refer to the parameter during the sequence.

Example of the Display Form for an Item:

Category address: [Function] - [Set function] - [General] - [Weight]

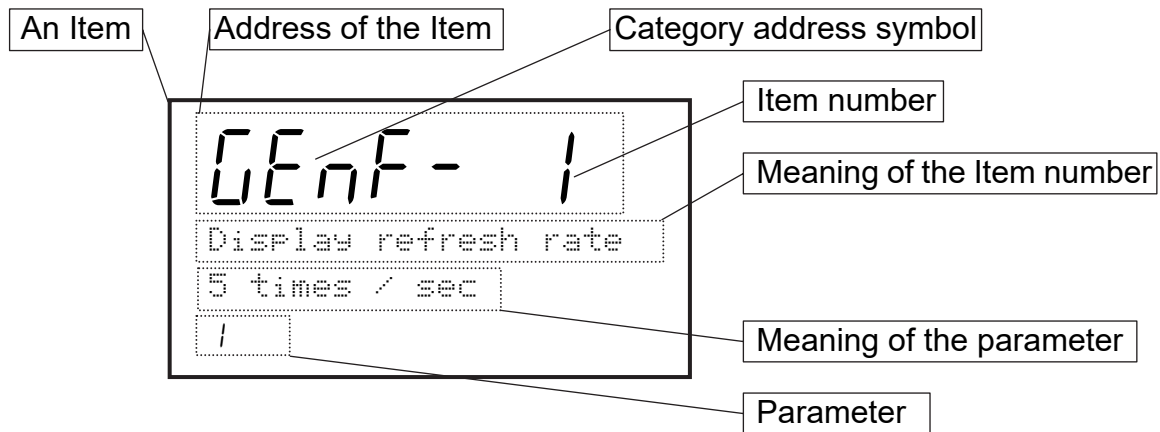

Caution

- **When entering Set function of the function mode, the current weighing sequence is stopped.**

11.1.1. Operation Keys

To enter the function list	Press and hold the ENTER key and press the ↵ key in the weighing mode. Select the menu Function using the ↵ key and the ENTER key.
To select the parameter address	The ↵ , SHIFT + ↵ , ENTER , ESC keys.
To change the parameter	The ↵ , SHIFT + ↵ , Alphanumerical , ENTER , ESC keys.
To store it and exit the mode (To return to weighing mode)	The ESC key.

11.1.2. Outline of the Function List

Category Address	Start Item
Function	
Function reference	
General	
Weight	GenF- 1
Sub display	Sub F 1
Other	othF- 1
Sequence	
Basic	59 F- 1
Control	59 F-21
Timer	59 F-41
Zero Track	59 F-71
Other	59 F-81
Control I/O	
Input	In F- 1
Output	OutF- 1
Serial	
C. Loop	CL F- 1
RS-485	r5 F- 1
Option	
Slot1	Refer to options below.
Slot2	
Slot3	
Set Function	
The same as the "Function reference".	

Options

Category Address	Start Item
Option	
Slot nn (nn: Slot number for the option to be installed in)	
BCD output, OP-01	01 F- 1
Relay output, OP-02	02 F- 1
RS-422/485, OP-03	03 F- 1
RS-232C, OP-04	04 F- 1
Parallel I/O, OP-05	05 F- 1
Analog output, OP-07	07 F- 1



11.2. Referring Parameters

- Use this mode to refer to the parameters in the weighing sequence.
- The temporary parameters can be input and used concerning the digital filter and weighing sequence timers in the weighing sequence.
 - [GEnF- 2] Digital filtering
 [Function] - [Function setting] - [General] - [Weighing]

 - [GEnF- 3] Sampling frequency divisor
 [Function] - [Function setting] - [General] - [Weighing]

 - [59 F-31] to [59 F-48]
 Weighing sequence timers
 [Function] - [Function setting] - [Sequence] - [Timer]
- The temporary parameters can be reset by the following operation.
 - When entering into standby mode.
 - When entering into calibration mode.
 - When entering into function setting of the menu.

Operation Example

- Step 1 Press and hold the **ENTER** key and press the **↵** key to display the menu.
- Step 2 Select `Function` using the **↵** key and press the **ENTER** key.
- Step 3 Enter `Refer` function using the **ENTER** key.
- Step 4 Refer parameters or input temporary parameters.
- Step 5 Press the **ESC** key to return to the weighing mode several times.

Operation Example to Store Temporary Parameters

- Step 1 Press and hold the **ENTER** key and press the **↵** key to display the menu.
- Step 2 Select `Function` using the **↵** key and press the **ENTER** key.
- Step 3 Enter `Refer` function using the **ENTER** key.
- Step 4 Input temporary parameters.
- Step 5 Press the **ESC** key and enter into `Set` function using the **↵** and **ENTER** key.
Then the weighing mode stops and parameters are stored.
- Step 6 Press the **ESC** key to return the normal stop mode.



11.3. Parameter List

Category address: [Function] – [Set Function] – [General] – [Weighing]

Category address symbol	Name	Descriptions	Range and choices	Default
ⒺEnF- 1	Display refresh rate	1: 5 times / second 2: 10 times /second 3: 20 times / second	1 to 3	2
ⒺEnF- 2	Digital filter	0: Not used Select 3dB band for two low pass filters. 1: 11 Hz 2: 8.0 Hz 3: 5.6 Hz 4: 4.0 Hz 5: 2.8 Hz 6: 2.0 Hz 7: 1.4 Hz 8: 1.0 Hz 9: 0.7 Hz	0 to 99	4 8
		<pre> graph TD ADC[A/D converter] --> F1[First filter] F1 --> F2[Second filter] </pre>		
ⒺEnF- 3	Sampling frequency divider	Use to decrease the cut-off frequency of the digital filter.	0 to 10	1
ⒺEnF- 4	Stability detection time	The detection condition concerning stability. 0.0 : Stable at anytime.	0.0 to 9.9 s	1.0 s
ⒺEnF- 5	Stability detection motion		0.0 to 9.9 d	2.0 d
ⒺEnF- 6	Zero range	The range to zero the gross display. Center of range is zero calibration. Unit: percentage of weighing capacity.	0 to 30 %	5 %
ⒺEnF- 7	Zero tracking time	The function automatically traces the weighing deviation at nearly zero point and keeps zero display of gross display. If parameter is 0.0, it does not work.	0.0 to 9.9 s	0.0 s
ⒺEnF- 8	Zero tracking motion		0.0 to 9.9 d	0.0 d
ⒺEnF- 9	Tare & zero unstable UGT	When unstable weighing, whether zero or tare command is used. 0 :Disabled Relations: 1 :Enabled ⒺEnF- 4, 5	0 to 1	1
ⒺEnF- 10	Tare at (-) gross weight	When negative weighing, whether tare command is used. 0 :Prohibit tare. 1 :Permission to tare.	0 to 1	1
ⒺEnF- 11	Preset tare	Preset tare 0 :Not used 1 :Use	0 to 1	1

Category address symbol	Name	Descriptions	Range and choices	Default
GE _n F-12	Preset tare=0 choose	1: If tare value of code is zero, the last tare value is used. 2: If tare value of code is zero, tare is set to zero.	1 to 2	1
GE _n F-13	Clear mode at power ON	The action at turning the indicator on. First bit: Zero Second bit: Not used Third bit: Tare Fourth bit: Tare clear 0: Not used 1: Use	0000 to 1111	0000

s : second
d : digit
WGT : weight

Category address: [Function] – [Set Function] – [General] – [Sub display]

Category address symbol	Name	Descriptions	Range and choices	Default
<i>SUBF- 1</i>	Weighing display	0: Basic format 1: Custom format	0 to 1	0

- Refer to "8.20. Customizing the Sub Display"
- When custom format is used (When [*SUBF- 1*] [*1*]), set items to be displayed in the sub-display.

Display to Store Items

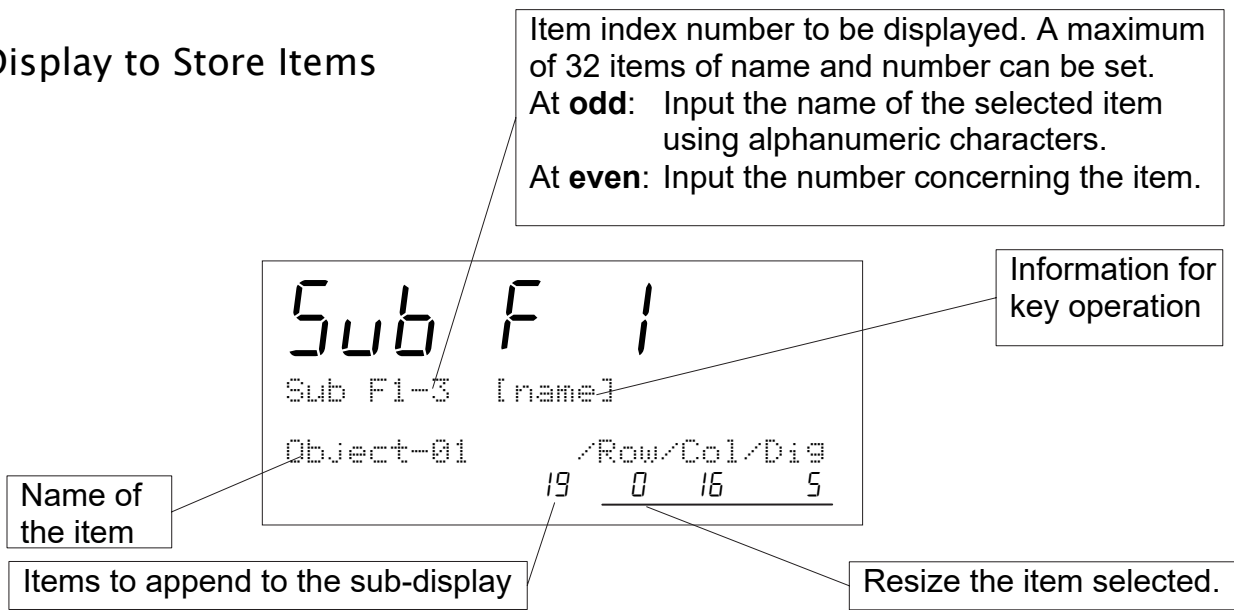

Row and Column Address

	0	1	2	3	4	5	6	7	8	9	10	11	12	13	14	15	16	17	18	19	20	21	22	23	24	25	26	
0																												
1																												
2																												
3																												

Row 0 and 2 are dot matrix display for alphanumeric character.
 Row 1 and 3 are 7-segment display for numerical character.

Items to append to the sub-display

No.	Item Name and Description	Row size	Column size	Figures
0	Not displayed	0 to 3	0 to 26	1 to 12
1	Code name			
2	Target			
3	Hi			
4	Lo			
5	HiHi			
6	LoLo			
7	Zero band			
8	Count of target data			
9	Tare			
10	Target Count			
11	Count of total data			
12	Count of OK data			
13	Count of NG (without OK data)			
14	Count of Hi data			
15	Count of Lo data			
16	Count of HiHi data			
17	Count of LoLo data			
18	Count of foreign matter			
19	Count of duplication			
20	Count of crush			
21	Maximum value of adequate data			
22	Minimum value of adequate data			
23	Average of adequate data			
24	Standard deviation of adequate data σ_{n-1}			
25	Population standard deviation of adequate data σ_n			
26	Total weight of adequate data			
27	Gross			
28	Net			
29	Graph			

Example of Basic Display Layout

- Store items according to the arrow in order. The order is from upper-left side item to the right item and lower-left item to the right in order.

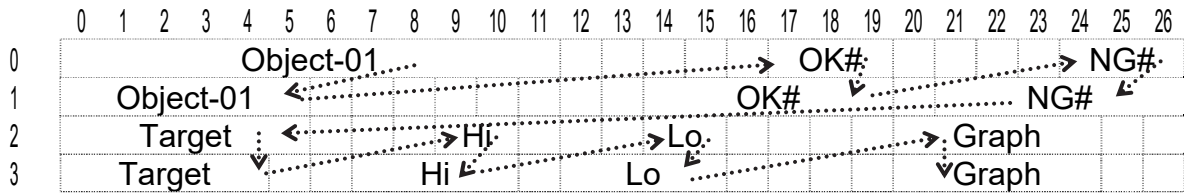

Object-01	OK#	NG#
Code 0	20	1
Target	Hi	Lo
10000	1500	1000
	L	H

Parameter List of Example

No.	Item	Code	Row	Column	Digit
Sub F1- 1	Object-01	Name	1	0	12
Sub F1- 2	Object-01	Number	1	0	6
Sub F1- 3	OK#	Name	12	0	17
Sub F1- 4	OK#	Number	12	1	14
Sub F1- 5	NG#	Name	13	0	24
Sub F1- 6	NG#	Number	13	1	21
Sub F1- 7	Target	Name	2	2	0
Sub F1- 8	Target	Number	2	3	1
Sub F1- 9	Hi	Name	3	2	9
Sub F1- 10	Hi	Number	3	3	7
Sub F1- 11	Lo	Name	4	2	14
Sub F1- 12	Lo	Number	4	3	12
Sub F1- 13	Graph	Name	29	2	20
Sub F1- 14	Graph	Number	29	3	20

Category address: [Function] – [Set Function] – [General] – [Sub-display]

Category address symbol	Name	Descriptions	Range and choices	Default
5UBF- 2	Activity indicator	Graphic Status Indicator 0: Hide 1: Upper side 2: Lower side	0 to 1	1

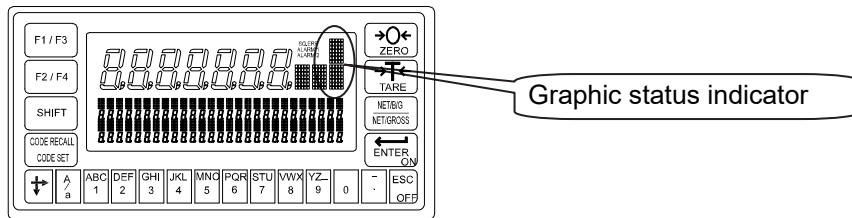

Upper Side	Description	
LoLo	The current result is LoLo.	
Lo	The current result is Lo.	
OK	The current result is OK.	
Hi	The current result is Hi	
HiHi	The current result is HiHi	
Foreign matter	It is displayed, when detecting foreign matter.	
Other weighing errors. Duplication, Crush or etc.		

Lower Side	Description	
The conveyor is in motion.		
Loading symbol	It is displayed until the evaluation delay timer 43 is up after detecting the article on the weighing conveyor. It is not displayed in OK mode [59 F-0 1] [3] or manual mode [59 F-0 1] [4].	
Averaging symbol	It is in the process of evaluation.	
Forwarding symbol	It is displayed until the weighing value is within the zero band after forwarding the article. It is not displayed in OK mode [59 F-0 1] [3] or manual mode [59 F-0 1] [4].	
Counter finish	The counter of the article has reached the preset limitation.	
Pause	It has no symbol.	

Category address: [Function] – [Set Function] – [General] – [Others]

Category address symbol	Name	Descriptions	Range and choices	Default
<i>athF- 1</i>	Key lock 0:Unlock 1:Lock	Set the action of each key. Bit 1: F1 key Bit 2: F2 key Bit 3: Start Bit 4: Stop Bit 5: Code recall Bit 6: Code set Bit 7: Zero Bit 8: Tare Bit 9: Buzzer stop Bit 10: Total clear Bit 11: Off 0: Unlock 1: Lock	0000000 0000 to 1111111 1111	00000 00000 0
<i>athF- 2</i>	F1 key function	0 No function 1 Manual print key 2 Hold 3 (Internal reservation) 4 Tare clear 5 Gross / Net	0 to 24	0
<i>athF- 3</i>	F2 key function	6 Cancel last judgement 7 Force target finish 8 Error reset key 9 Clear all code totals 10 Total print		
<i>athF- 4</i>	Tare Header	Normal tare and preset tare for the current loop output or RS-485 of serial interface can be classified using header format. This item has no effect in command mode and jet stream mode. 0: All tare header of tare is "TR" 1: Use "PT" for preset tare header and "T" of tare header	0 ot 1	0
<i>athF- 5</i>	PT printing with net weight	The selection to print preset tare in the current loop output or RS-485 of serial interface. This item has no effect in command mode and jet stream mode. 0: No (Preset tare not output) 1: Yes (To output preset tare)	0 ot 1	0

Category address symbol	Name	Descriptions	Range and choices	Default
<i>athF- 6</i>	Printing when unstable	The selection to print unstable data or data of out of range in the current loop output or RS-485 of serial interface. This item has no effect in command mode and jet stream mode. 0: Not print output 1: Print	0 or 1	0
<i>athF- 7</i>	Repeat lock 0: Unlock 1: Lock	The selection to avoid key operation error. Bit 0: Total Bit 1: Manual print 0: Unlock 1: Lock (Cancel duplicated command input)	00 to 11	00
<i>athF- 8</i>	Save data	Select a backup method for material code and recipe code. 0: Store in RAM 1: Store in flash memory	1 to 2	1
<i>athF- 9</i>	Line feed	The selection to do line feed for the current loop output or RS-485 of serial interface. This item has no effect in command mode and jet stream mode. 0: Not print output 1: Print (C_R or $C_{R L_F}$ is output in the front of data)	0 or 1	0
<i>athF- 10</i>	Use coma or dot at SI/F	The selection of decimal point format for the current loop output or RS-485 of serial interface. 1: . Dot 2: , Comma	1 to 2	1

Category address: [Function] – [Set Function] – [Sequence] – [Basic]

Category address symbol	Name	Descriptions	Range and choices	Default
59 F- 1	Weighing mode	1: Automatic mode 2: Conveyor stop mode 3: OK mode 4: Manual mode 5: Simple mode	1 to 5	1
59 F- 2	Selection of comparison	Setpoints and comparison method Refer to "8.2. Judgement and Selector Action" 1: 3 levels with target 2: 3 levels without target 3: 5 levels with target 4: 5 levels without target	1 to 4	1
59 F- 3	Loss-in weight	0: Not used 1: Use	0 to 1	0
59 F- 4	Output of zero band	0: Gross <= Zero band 1: Gross <= Zero band	1 to 2	1
59 F- 5	Buzzer condition 1	Buzzer continuously sounds. Bit 1: LoLo Bit 2: Lo Bit 3: OK Bit 4: Hi Bit 5: HiHi Bit 6: Foreign matter detection Bit 7: Duplication Bit 8: Crush Bit 9: Target number finish 0: No sound 1: buzzer sounds	0000000 00 to 1111111 11	11011 1111
59 F- 6	Buzzer condition 2	Buzzer sounds at Lo. Interval is 0.5Hz. Settings is the same as [59 F- 5].	0000000 00 to 1111111 11	00000 0000
59 F- 7	Buzzer condition 3	Buzzer sounds at OK. Interval is 1Hz. Settings is the same as [59 F- 5].		
59 F- 8	Buzzer condition 4	Buzzer sounds at Hi. Interval is 2Hz. Settings is the same as [59 F- 5].		
59 F- 9	Buzzer condition 5	Buzzer sounds at OK. Interval is 4Hz. Settings is the same as [59 F- 5].		
59 F- 10	Buzzer condition 6	Buzzer sounds at Hi. Interval is 8Hz. Settings is the same as [59 F- 5].		

Category address symbol	Name	Descriptions	Range and choices	Default
59 F-11	Digital filter on running	Select 3dB band for two low pass digital filter. 0: Not used 1: 11 Hz 2: 8.0 Hz 3: 5.6 Hz 4: 4.0 Hz 5: 2.8 Hz 6: 2.0 Hz 7: 1.4 Hz 8: 1.0 Hz 9: 0.7 Hz	0 to 99	4 8
59 F-12	Run gravity compensation	Motion compensation for automatic mode [59 F-1][1]. Compensation value = (compensation coefficient) x (weighing value in motion)	0.90000 to 1.10000	1.00000

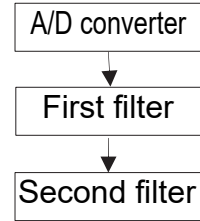

Category address: [Function] – [Set Function] – [Sequence] – [Control]

Category address symbol	Name	Descriptions	Range and choices	Default
59 F-21	Conveyor stop condition	Bit 1: LoLo Bit 2: Lo Bit 3: OK Bit 4: Hi Bit 5: HiHi Bit 6: Foreign matter detection Bit 7: Duplication Bit 8: Crush Bit 9: Target number finish 0: Not stopped 1: stop	0000000 00 to 1111111 11	11011 1111
59 F-22	Selector 1 condition	Bit 1: LoLo Bit 2: Lo	0000000 0 to 1111111 1	11011 111
59 F-23	Selector 2 condition	Bit 3: OK Bit 4: Hi		
59 F-24	Selector 3 condition	Bit 5: HiHi Bit 6: Foreign matter detection		
59 F-25	Selector 4 condition	Bit 7: Duplication Bit 8: Crush		
59 F-26	Selector 5 condition	0: Not pushed		
59 F-27	Selector 6 condition	1: Push		
59 F-28	Finish condition	The target count to finish measurement. 1: OK count is used 2: Total count is used	1 to 2	1
59 F-29	Detector	The condition of detecting the article. Eval delay timer [59 F-43] starts. Refer to "8.5. Detection Method". 1: Detecting the front of the article with the position sensor. 2: Detecting the end of the article with the position sensor. 3: Detecting gross above the zero band. 4: Detecting gross within the zero band.	1 to 4	1
59 F-30	Compare output OFF timing	The timing of compare output OFF for when Compare output timer [59 F-45] is 0. 0: At the time the next article detected. 1: At the next judgement.	0 to 1	0

Category address: [Function] – [Set Function] – [Sequence] – [Timer]

Category address symbol	Name	Descriptions	Range and choices	Default
59 F-41	Buzzer on timer	The time to sound the buzzer. If it is 0, buzzer sounds until it is canceled.	0.00 to 99.99 s	1.00 s
59 F-42	Chattering timer	The time to ignore position sensor.	0.00 to 99.99 s	0.20 s
59 F-43	Eval delay timer	The time between detecting an article and averaging it.	0.00 to 99.99 s	1.00 s
59 F-44	Average timer	The time to average the weighing value.	0.00 to 9.99 s	1.00 s
59 F-45	Compare output timer	The output time of judgement output. If it is 0, it is output until next judgement.	0.00to 99.99 s	3.00 s
59 F-46	Selection out 1 delay timer	Delay time of output of selector 1 after judgement.	0.00to 99.99 s	3.00 s
59 F-47	Selection out 2 delay timer	Delay time of output of selector 2 after judgement.	0.00to 99.99 s	3.00 s
59 F-48	Selection out 3 delay timer	Delay time of output of selector 3 after judgement.	0.00to 99.99 s	3.00 s
59 F-49	Selection out 4 delay timer	Delay time of output of selector 4 after judgement.	0.00to 99.99 s	3.00 s
59 F-50	Selection out 5 delay timer	Delay time of output of selector 5 after judgement.	0.00to 99.99 s	3.00 s
59 F-51	Selection out 6 delay timer	Delay time of output of selector 6 after judgement.	0.00to 99.99 s	3.00 s
59 F-52	Select output 1 timer	The output time of selector 1.	0.00to 99.99 s	1.00 s
59 F-53	Select output 2 timer	The output time of selector 2.	0.00to 99.99 s	1.00 s
59 F-54	Select output 3 timer	The output time of selector 3.	0.00to 99.99 s	1.00 s
59 F-55	Select output 4 timer	The output time of selector 4.	0.00to 99.99 s	1.00 s
59 F-56	Select output 5 timer	The output time of selector 5.	0.00to 99.99 s	1.00 s
59 F-57	Select output 6 timer	The output time of selector 6.	0.00to 99.99 s	1.00 s
59 F-58	Foreign detect timer	The delay time of foreign matter detection. When it is up, it is output. Refer to "6.3. Foreign Matter Detection"	0.00to 99.99 s	3.00 s
59 F-59	Conveyor stop delay timer	The delay timer to stop conveyor after judgement for OK mode. Refer to "6.4. OK Mode".	0.00to 99.99 s	3.00 s
59 F-60	Target sense timer	If detection at the position sensor is in continuous status when the timer has elapsed, the device will show article duplication errors. Use these settings for the identification of preceding and following articles weighed when using the high-speed conveyor.	0.00to 99.99 s	0.00 s

s : second, d: digit

Category address: [Function] – [Set Function] – [Sequence] – [Zero track]

Parameters for Dynamic Zero Tracking Function

Category address symbol	Name	Descriptions	Range and choices	Default
59 F-71	Zero tracking back timer	The time to stop zero tacking before weighing the article.	0.0 to 5.0 s	1.0 s
59 F-72	Tracking average timer	Average time.	0.0 to 5.0 s	1.0 s
59 F-73	Tracking MIN interval	Minimum interval between weighings. If next weighing performs before the timer is up, zero tracking is not performed.	0.0 to 99.9 s	10.0 s
59 F-74	Tracking amplitude	Tolerance value to perform zero tacking. If absolute average value of zero tracking is above this parameter, zero tracking is not performed.	0.0 to 99.9 d	0.0 d

Refer to "8.1.2. Dynamic Zero Tracking Function".

s : second, **d**: digit

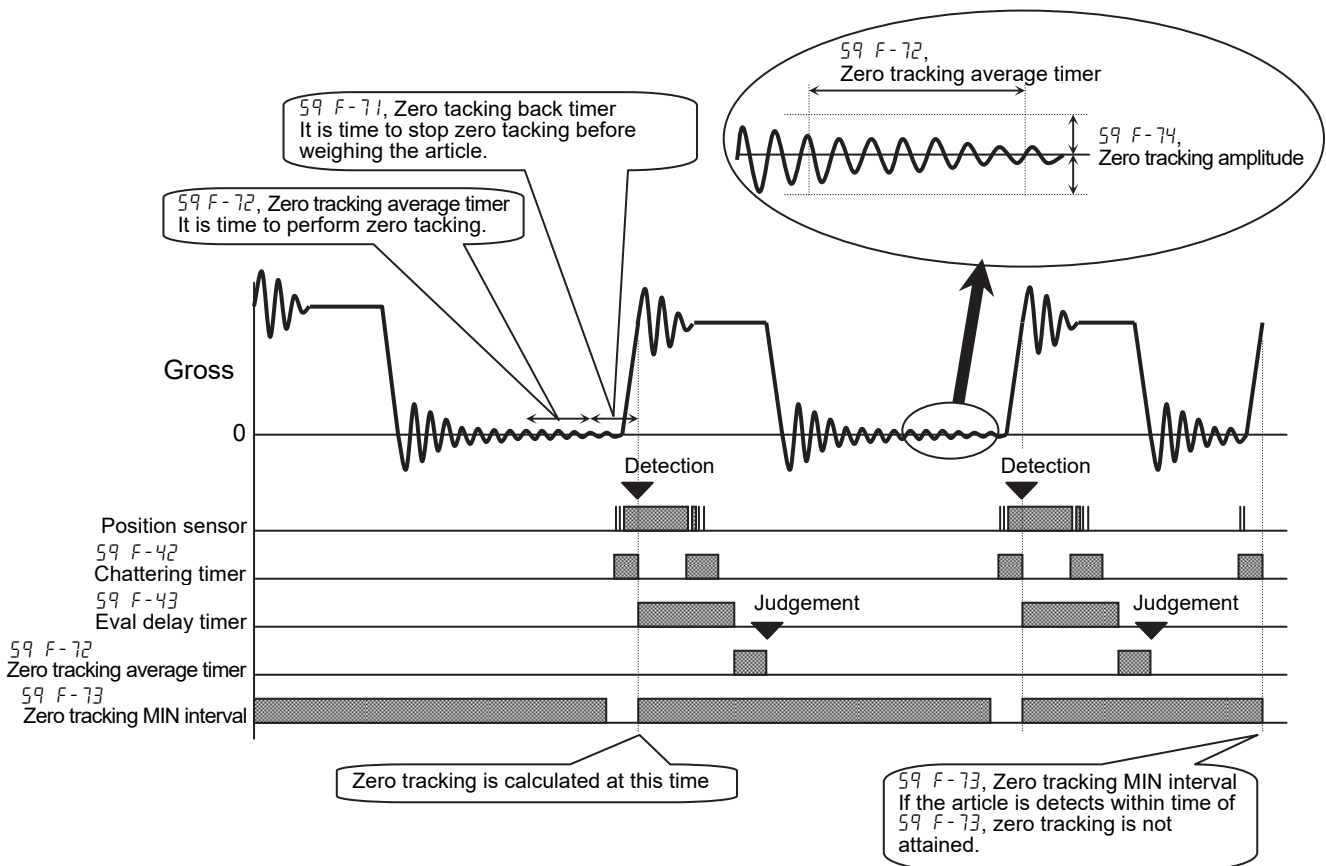

Category address: [Function] – [Set Function] – [Sequence] – [Other]

Category address symbol	Name	Descriptions	Range and choices	Default
59 F-81	Code recall method	Refer to "7.3. The Method to Recall a Code" 1: Key/Serial I/F 2: Parallel I/F 3: External switch control	1 to 3	1
59 F-82	Hide element of code	When recalling the code, the function to hide preset item. Bit 1: Hi Bit 2: Lo Bit 3: HiHi Bit 4: LoLo Bit 5: Zero band Bit 6: Full Bit 7: Target cout Bit 8: Tare 0: Show item 1: Hide item	00000000 to 11111111	00000 000
59 F-83	Safety check	The safety check function stops the check weighing sequence, when an error occurs. There are eight inputs for this function. Assign these inputs to input terminal. Refer to "8.15. Safety Check Function"		

Category address: [Function] – [Set Function] – [Control I/O] – [Input]

The list to assign the function for the input terminal of the control I/O

No.	Function Description	Read	No.	Function Description	Read
0	No function	-	26	Do not change. Internal reservation.	
1	Zero	Edge	27		
2	(Internal reservation)	-	28	Safety check input 1	Level
3	Tare	Edge	29	Safety check input 2	Level
4	Tare clear	Edge	30	Safety check input 3	Level
5	Start	Edge	31	Safety check input 4	Level
6	Stop	Edge	32	Safety check input 5	Level
7	Sensor	Level	33	Safety check input 6	Level
8	Buzzer stop	Edge	34	Safety check input 7	Level
9	Foreign matter detector	Edge	35	Safety check input 8	Level
10	Do not change. Internal reservation.		36	Forced target finish	Edge
11			37	Do not change. Internal reservation.	
12	Cancel the last result	Edge	38		
13	Emergency stop	Level	39	Manual start for conveyor	Level
14	Code number, BCD 1	Level	40	Do not change. Internal reservation.	
15	Code number, BCD 2	Level	41		
16	Code number, BCD 4	Level	42		
17	Code number, BCD 8	Level	43		
18	Code number, BCD 10	Level	44	Error reset	Edge
19	Code number, BCD 20	Level	45	Hold	Level
20	Code number, BCD 40	Level	46	Key unlock	Level
21	Code number, BCD 80	Level	47	Manual print command	Edge
22	Do not change. Internal use.		48	EXternal switch control OFF: key, ON: digital switch	Level
23	Total print	Edge			
24	Clear totals of active code	Edge	49	Do not change. Internal reservation.	
25	Clear totals of all codes	Edge	50	Net / gross	Edge

Caution

- ❑ Do not assign the same function to multiple input terminals of the control I/O and OP-05.

Default functions of the input terminals of the control I/O.

Category address symbol	Terminal name	Description of default settings	Default No.
<i>In F- 1</i>	Input terminal A1	Zero	1
<i>In F- 2</i>	Input terminal A2	Tare	3
<i>In F- 3</i>	Input terminal A3	Tare clear	5
<i>In F- 4</i>	Input terminal A4	Batch start	6
<i>In F- 5</i>	Input terminal A5	Emergency stop	7
<i>In F- 6</i>	Input terminal A6	Code number, BCD 1	14
<i>In F- 7</i>	Input terminal A7	Code number, BCD 2	15
<i>In F- 8</i>	Input terminal A8	Code number, BCD 4	16
<i>In F- 9</i>	Input terminal A9	Pause	13
<i>In F- 10</i>	Input terminal A10	Restart	8
<i>In F- 11</i>	Input terminal A11	Error reset	44

Category address: [Function] – [Set Function] – [Control I/O] – [Output]

The list to assign the function for the output terminal of the control I/O

No.	Function Description	No.	Function Description	
0	No function	23	Alam 1	
1	Stable	24	Alam 2	
2	Zero band	25	Zero error	
3	Full	26	Capacity exceeded (Out of range)	
4	LoLo	27	Buzzer	
5	Lo	28	Tare	
6	OK	29	Center of zero	
7	Hi	30	Gross display	
8	HiHi	31	Net display	
9	Foreing matter detection	32	During hold	
10	Duplication	33	Internal reservation	
11	NG	34		
12	Finish target	35		
13	During opetation	36		
14	Conveyor	37		
15	Busy	38		
16	Managing foreign matter	39		
17	Crush	40		
18	Finish weighing	41		Selection output 1
19	Online. If weighing sequence is available, 1Hz pluse is output.	42		Selection output 2
		43	Selection output 3	
20	Internal reservation	44	Selection output 4	
21	Input acknowledge. If there is an input signal, 0.5 sec. pulse is output.	45	Selection output 5	
		46	Selection output 6	
22	Weighing sequence error			

Default functions of the output terminals of the control I/O.

Category address symbol	Terminal name	Description of default settings	Default No.
<i>OutF- 1</i>	Output terminal B1	Lo	5
<i>OutF- 2</i>	Output terminal B2	OK	6
<i>OutF- 3</i>	Output terminal B3	Hi	7
<i>OutF- 4</i>	Output terminal B4	NG	11
<i>OutF- 5</i>	Output terminal B5	Conveyor	14
<i>OutF- 6</i>	Output terminal B6	Selection output 1	41
<i>OutF- 7</i>	Output terminal B7	Buzzer	27
<i>OutF- 8</i>	Output terminal B8	Finish of target count	12
<i>OutF- 9</i>	Output terminal B9	Weighing sequence error	22
<i>OutF- 10</i>	Output terminal B10	Alam 1	23
<i>OutF- 11</i>	Output terminal B11	Alam 2	24

Definitions of word of Input Terminals for Control I/O

Function Name	No	Action and Description
Start	5	The detection of "Start input" and "Stop input" uses leading edge.
Stop	6	The detection of "Emergency stop" uses signal level.
Emergency stop	13	If "Emergency stop" is input, the conveyor is stopped, selectors turn off and all operation input is inhibited for safety.
Cancel the last result	12	The function cancels the last result from the total.
Manual start for conveyor	39	Use for maintenance. It can move conveyor independently.
Buzzer stop	8	It is the same as the buzzer stop key. It can stop buzzer when it sounds.
Clear totals of active code	24	It is the same as the clear total key. The total data of the current code can be cleared.
Clear totals of all codes	25	The total data of the all codes can be cleared.

Definitions of word of Output Terminals for Control I/O

Function Name	No	Action and Description
NG	11	If the result is not in the range of "OK", terminal turns on.
Conveyor	14	The signal to control the motor of the conveyor. While the signal turns on, it means the rotation of the motor.
Finish target	12	When the count of the weighing sequence reaches the target count, this terminal turns on.
BUSY	15	When this terminal turns on, the AD-4404 is in process. When there is an article on the conveyor, this terminal turns on. Use the terminal to avoid sequence error. Example: Crush.

Category address: [Function] – [Set Function] – [Serial] – [RS-485]

Category address symbol	Name	Descriptions	Range and choices	Default
r5 F- 1	Output data	When jet stream mode of [r5 F- 2] is used, 1, 2 or 3 can be selected. When the display value is held in jet stream mode, output is not stopped. 1: Displayed value 2: Gross value 3: Net value 4: Tare value 5: Gross value/ Net value/ Tare value 6: Displayed value with code 7: Gross value with code 8: Net value with code 9: Tare value with code 10: Gross value/ Net value/ Tare value with code	1 to 10	1
r5 F- 2	Communication mode	1: Stream mode 2: Auto print mode 3: Manual print mode 4: Jet stream mode 5: Command mode 6: MODBUS	1 to 6	5
r5 F- 3	Baud rate	1: 600 bps 2: 1200 bps 3: 2400 bps 4: 4800 bps 5: 9600 bps 6: 19200 bps 7: 38400 bps (Jet stream mode only)	1 to 7	5
r5 F- 4	Parity check	0: Not used 1: Odd 2: Even	0 to 2	0
r5 F- 5	Character length	7: 7 bits 8: 8 bits	7, 8	8
r5 F- 6	Stop bits	1: 1 bit 2: 2:bits	1 to 2	1
r5 F- 7	Terminator	1: CR CR: 0Dh 2: CR LF LF: 0Ah	1 to 2	2
r5 F- 8	Address	0: Address not used 1 to 99: Address used	0 to 99	0
r5 F- 9	Response timer	Set the waiting timer from receiving command to transmitting a response.	0.0 to 25.5 s	0.0 s
r5 F- 10	Do not change. Internal reservation.			
r5 F- 11				

Category address symbol	Name	Descriptions	Range and choices	Default
r5 F- 12	Process print	0: Do not print total data 1: Total print mode 1 2: Total print mode 2 3: Total print mode 3 4: Total print mode 4 5: Total print mode 5 6: Total print mode 6 7: Total print mode 7	0 to 7	0
r5 F- 13	Print for date & time	0: Do not print date and time 1: Date before total 2: Time before total 3: Date and time before total 4: Date after total 5: Time after total 6: Date and time after total	0 to 6	0
r5 F- 14	Print Code by start key	0: Not printed 1: Printed	0 to 1	1

s : second

Category address: [Function] – [Set Function] – [Serial] – [C.loop]

Category address symbol	Name	Descriptions	Range and choices	Default
[L F- 1	Output data	1: Displayed value 2: Gross value 3: Net value 4: Tare value 5: Gross value/ Net value/ Tare value 6: Displayed value with code 7: Gross value with code 8: Net value with code 9: Tare value with code 10: Gross value/ Net value/ Tare value with code	1 to 10	1
[L F- 2	Communication mode	1: Stream mode 2: Auto print mode 3: Manual print mode	1 to 3	1
[L F- 3	Baud rate	1: 600 bps 2: 1200 bps 3: 2400 bps	1 to 3	3
[L F- 4	Set continuous output baud rate	Set the interval time between output data. Stream mode uses 0.0 s.	0.00 to 2.55 s	0.00 s
[L F- 5	Parity check	0: Not used 1: Odd 2: Even	0 to 2	0
[L F- 6	Character length	7: 7 bits 8: 8 bits	7, 8	8
[L F- 7	Process print	0: Do not print total data 1: Total print mode 1 2: Total print mode 2 3: Total print mode 3 4: Total print mode 4 5: Total print mode 5 6: Total print mode 6 7: Total print mode 7	0 to 7	0
[L F- 8	Print for date & time	0: Do not print date and time 1: Date before total 2: Time before total 3: Date and time before total 4: Date after total 5: Time after total 6: Date and time after total	0 to 6	0

s : second

[L F- 9	Print Code by start key	0: Not printed 1: Printed	0 to 1	1
---------	----------------------------	------------------------------	--------	---

s : second

Category address: [Function] – [Set Function] – [Option] – [slot n] – OP-01]

OP-01: Option BCD Output

slot n : slot number

Category address symbol	Name	Descriptions	Range and choices	Default
01F-1	Output data	1: Displayed value 2: Gross value 3: Net value 4: Tare value 5: Current code total 6: Current code total count 7: (Not used) 8: (Not used) 9: Code number 10: Error alarm number	1 to 10	1
01F-3	Communication mode	1: Stream mode 2: Auto print mode 3: Manual print mode 4: Jet stream mode (each sampling)	1 to 4	1
01F-4	Output logic	1: Positive logic 2: Negative logic	1 to 2	2

Category address: [Function] – [Set Function] – [Option] – [slot n] – [OP-02]

OP-02: Option Relay Output

slot n : slot number

- The functions of the relay output are the same as the functions of the output of the control I/O.
 Refer to the terminal functions of the output of the control I/O.
 [Function] - [Set Function] - [Control I/O] - [Output]
- Assign the function to the relay output.

Category address symbol	Name	Descriptions of default settings	Range and choices	Default
02 F- 1	Out 1(B 1) function	Not used	0 to 64	0
02 F- 2	Out 2(B 2) function	Not used	0 to 64	0
02 F- 3	Out 3(B 3) function	Not used	0 to 64	0
02 F- 4	Out 4(B 4) function	Not used	0 to 64	0
02 F- 5	Out 5(B 5) function	Not used	0 to 64	0
02 F- 7	Out 7(B 7) function	Not used	0 to 64	0
02 F- 8	Out 8(B 8) function	Not used	0 to 64	0
02 F- 9	Out 9(B 9) function	Not used	0 to 64	0
02 F- 10	Out10(B10) function	Not used	0 to 64	0

Category address: [Function] – [Set Function] – [Option] – [slot n] – [OP-03] or

Category address: [Function] – [Set Function] – [Option] – [slot n] – [OP-04]

slot n : slot number

OP-04: Option RS-232C Interface

OP-03: Option RS-422 / RS-485 Interface

Category address symbol	Name	Descriptions	Range and choices	Default
03 F- 1 04 F- 1	Output data	When jet stream mode of [r 5 F- 2] is used, 1, 2 or 3 can be selected. When the display value is held in jet stream mode, output is not stopped. 1: Displayed value 2: Gross value 3: Net value 4: Tare value 5: Gross value/ Net value/ Tare value 6: Displayed value with code 7: Gross value with code 8: Net value with code 9: Tare value with code 10: Gross value/ Net value/ Tare value with code	1 to 10	1
03 F- 2 04 F- 2	Communication mode	1: Stream mode 2: Auto print mode 3: Manual print mode 4: Jet stream mode 5: Command mode	1 to 5	5
03 F- 3 04 F- 3	Baud rate	1: 600 bps 2: 1200 bps 3: 2400 bps 4: 4800 bps 5: 9600 bps 6: 19200 bps 7: 38400 bps (Jet stream mode only)	1 to 7	5
03 F- 4 04 F- 4	Parity check	0: Not used 1: Odd 2: Even	0 to 2	0
03 F- 5 04 F- 5	Character length	7: 7 bits 8: 8 bits	7, 8	8
03 F- 6 04 F- 6	Stop bits	1: 1 bit 2: 2:bits	1 to 2	1
03 F- 7 04 F- 7	Terminator	1: CR CR: 0Dh 2: CR LF LF: 0Ah	1 to 2	2
03 F- 8 04 F- 8	Address	0: Address is not used 1 to 99: Address is used	0 to 99	0

Category address symbol	Name	Descriptions	Range and choices	Default
03 F- 9	Response timer	Set the waiting timer from receiving command to transmitting a response.	0.00 to 2.55 s	0.00 s
03 F- 11	RS-422 / 485 switch	1: RS-422 2: RS-485	1 to 2	1
03 F- 12 04 F- 12	Process print	0: Do not print total data 1: Total print mode 1 2: Total print mode 2 3: Total print mode 3 4: Total print mode 4 5: Total print mode 5 6: Total print mode 6 7: Total print mode 7	0 to 7	0
03 F- 13 04 F- 13	Print for date & time	0: Do not print date and time 1: Date before total 2: Time before total 3: Date and time before total 4: Date after total 5: Time after total 6: Date and time after total	0 to 6	0
03 F- 14 04 F- 14	Print Code by start key	0: Not printed 1: Printed	0 to 1	1

Category address: [Function] – [Set Function] – [Option] – [slot n] – [OP-05]

OP-05: Option Parallel I/O

slot n : slot number

- The functions of the parallel I/O are the same as the functions of the control I/O. Refer to the terminal functions of the control I/O.
[Function] - [Set Function] - [Control I/O]
- Assign the function to the parallel I/O.

Caution

- **Do not assign the same function to multiple input terminals of the control I/O and OP-05.**

Input Terminals of OP-05

Category address symbol	Name	Descriptions of default settings	Range and choices	Default
05 F- 1	In 1(A 1) function	Not used.	0 to 50	0
05 F- 2	In 2(A 2) function		0 to 50	0
05 F- 3	In 3(A 3) function		0 to 50	0
05 F- 4	In 4(A 4) function		0 to 50	0
05 F- 5	In 5(A 5) function		0 to 50	0
05 F- 6	In 6(A 6) function		0 to 50	0
05 F- 7	In 7(A 7) function		0 to 50	0
05 F- 8	In 8(A 8) function		0 to 50	0
05 F- 9	In 9(A 9) function		0 to 50	0
05 F- 10	In 10(A10) function		0 to 50	0
05 F- 11	In 11(A11) function		0 to 50	0
05 F- 12	In 12(A12) function		0 to 50	0
05 F- 13	In 13(A13) function		0 to 50	0
05 F- 14	In 14(A14) function		0 to 50	0
05 F- 15	In 15(A15) function		0 to 50	0
05 F- 16	In 16(A16) function		0 to 50	0

Output Terminals of OP-05

- The functions of the parallel I/O are the same as the functions of the control I/O.
Refer to the terminal functions of the control I/O.
[Function] - [Set Function] - [Control I/O]
- Assign the function to the parallel I/O.

Category address symbol	Name	Descriptions of default settings	Range and choices	Default
05 F-17	Out 1(B 1) function	Not used	0 to 46	0
05 F-18	Out 2(B 2) function		0 to 46	0
05 F-19	Out 3(B 3) function		0 to 46	0
05 F-20	Out 4(B 4) function		0 to 46	0
05 F-21	Out 5(B 5) function		0 to 46	0
05 F-22	Out 6(B 6) function		0 to 46	0
05 F-23	Out 7(B 7) function		0 to 46	0
05 F-24	Out 8(B 8) function		0 to 46	0
05 F-25	Out 9(B 9) function		0 to 46	0
05 F-26	Out 10(B10) function		0 to 46	0
05 F-27	Out 11(B11) function		0 to 46	0
05 F-28	Out 12(B12) function		0 to 46	0
05 F-29	Out 13(B13) function		0 to 46	0
05 F-30	Out 14(B14) function		0 to 46	0
05 F-31	Out 15(B15) function		0 to 46	0
05 F-32	Out 16(B16) function		0 to 46	0

Category address: [Function] – [Set Function] – [Option] – [slot n] – [OP-07]

OP-07: Option Analog Output

slot n : slot number

- Refer to "9.10. Analog Output of Option OP-07"

Category address symbol	Name	Descriptions	Range and choices	Default
07 F- 1	Out put data	1: Displayed value 2: Gross value 3: Net value	1 to 3	1
07 F- 2	Weight at 4 mA	Set the weight value when 4 mA is output.	-999999 to 9999999	0
07 F- 3	Weight at 20 mA	Set the weight value when 20 mA is output.	-999999 to 9999999	16000



12. Specifications

General

Power supply	85 to 250 VAC, 50 or 60Hz, (Stable power source)
Power consumption	Approximately 30 VA
Physical dimensions	192 (W) x 96 (H) x 135 (D) mm
Weight	Approximately 1.8 kg
Panel cutout size	186 x 92 mm
Operation temperature	-5 °C to 40 °C
Battery life of backup RAM	Min.10 years at 25 °C, 5 years at 40 °C.

Analog to Digital Unit

Input sensitivity	Up to 0.3 μ V / digit
Zero adjustment range	0 to 2 mV /V (0 to 20 mV)
Measuerment range	0 to 3.2 mV /V (0 to 32 mV)
Input impedance	10 M Ω or greater
Loadcell excitation voltage	10 V DC \pm 5%
Maximum loadcells	8 pieces in parallel with 350 Ω loadcell
Span temperature coefficient	8 ppm/ °C
Zero temperature coefficient	0.2 μ V +8 ppm/ °C of dead load typ.
Non-linearity	0.01 % of F. S.
Input noise	Below \pm 0.3 μ Vp-p
A/D conversion	Δ - Σ conversion
A/D resolution	Approximately 1/1,000,000
Maximum display	16000 (to be able to cancel limitation)
Sampling rate	100 times per second
Digital span function	Loadcell offset, calibration using key operation to enter the sensitivity, resolution 1/1000
Re-calibration at A/D board replacement	Omissible (resolution 1/500)
Backup method	Calibration: Flash memory Function: Flash memory Code data: Backup RAM or flash memory Total data of code data: Backup RAM

Display

Main display	Fluorescent display, cobalt blue, height: 18mm, 7segment, 7 figures
Sub-display	Fluorescent display, cobalt blue, height: 5mm, 7segment, 54 figures and 5x7 dots, 54 figures
State indicator	Fluorescent display, cobalt blue, 8 Δ pieces, 10 symbols, 5x7 dots
Unit indicator	Fluorescent display, cobalt blue, height: 11mm, 5x7 dots, 2 figures
Symbols	Fluorescent display, cobalt blue, height: 11mm, 5x7 dots, 2 figures

Weighing sequence mode

Weighing mode Automatic Mode
 Conveyor Stop Mode
 OK Mode
 Manual Mode
 Simple Mode

Code data

Max. number of material codes 100 codes
Elements of the material code Name, Target weight, Hi, Lo, HiHi, LoLo, Zero band, Full, Preset tare, Target count, Total count, OK count, NG count, Hi count, Lo count, HiHi count, LoLo count, Foreign matter detection count, Duplication count, Crush count, Maximum, Minimum, Average, Standard deviation σ_{n-1} , Population standard deviation σ_n , Total of the weighing value

Connectors and interfaces

Power supply terminal, Loadcell terminal, Standard I/O terminal, Standard RS-485 interface, Current loop, keys and display

Standard I/O terminal

Refer to "9.1. Control I/O Function".

Standard RS-485 interface

Refer to "9.2. Built-in RS-485 Interface".
Refer to "9.3. Modbus Interface for RS-485".

Current loop

Refer to "9.4. Built-in Current Loop Output".

BCD Output of Option OP-01

Refer to "9.5. BCD Output of Option, OP-01".

Relay Output of Option OP-02

Refer to "9.6. Relay Output of Option OP-02".

RS-422/485 Interface of Option OP-03

Refer to "9.7. RS-422/485 Interface of Option OP-03".

RS-232C Interface of Option OP-04

Refer to "9.8. RS-232C Interface of Option OP-04".

Parallel I/O of Option OP-05

Refer to "9.9. Parallel I/O of Option OP-05".

Analog Output of Option OP-07

Refer to "9.10. Analog Output of Option OP-07".



12.1. Dimensions

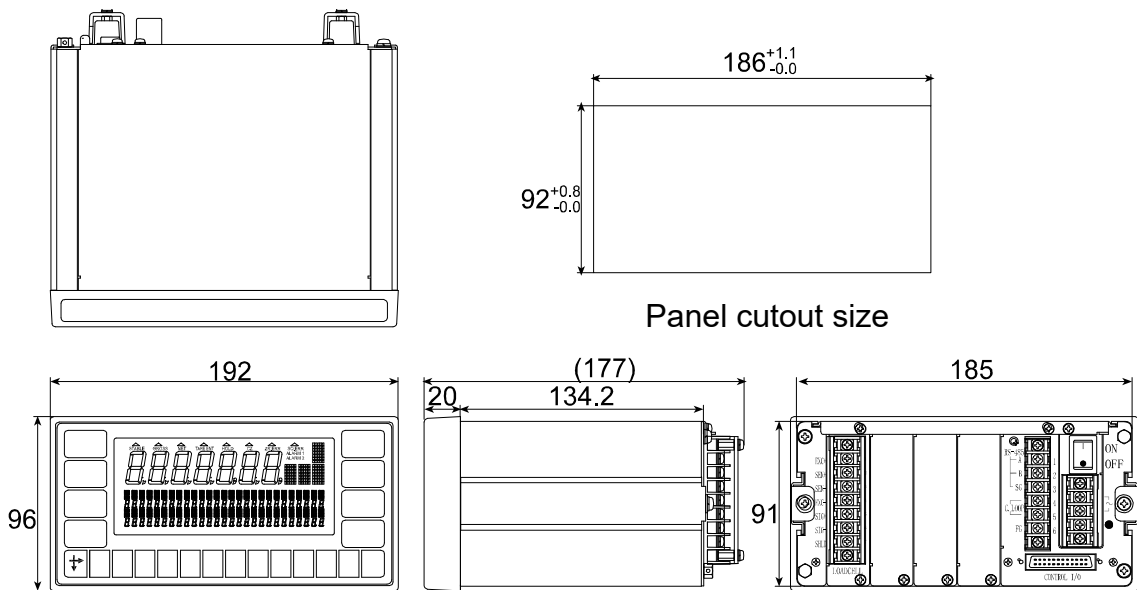

12.2. Accessories

Capacity label	1	
I/O connector	1	J1-361J024-AG
I/O connector cover	1	J1-360C024-B
RS-485, terminator resistor 100 Ω	1	RC-1/2100R
Cover of power supply terminal	1	07-40008561
Cover of RS-485 and current loop	1	TM-ML250C-A61.4
Cover of loadcell terminal	1	07-4008560
Rubber packing for panel mounting	1	06-4008562



13. Index

[Control I/O] - [Input].....	141
[Control I/O] - [Output]	142
[General] - [Others]	133
[General] - [Sub-display]	129, 132
[General] - [Weighing]	127
[Option] - [slot n] - [OP-02].....	149
[Option] - [slot n] - [OP-03].....	150
[Option] - [slot n] - [OP-04].....	150
[Option] - [slot n] - [OP-05].....	152
[Option] - [slot n] - [OP-07].....	154
[Option] - [slot n] - OP-01].....	148
[Sequence] - [Control]	135, 137
[Sequence] - [Other].....	140
[Sequence] - [Timer].....	138
[Sequence] - [Zero track]	139
[Serial] - [C.loop].....	146
[Serial] - [RS-485].....	144
⊕, Earth terminal	7
•, Standby indicator.....	8
<i>01 F</i>	148
<i>02 F</i>	149
<i>03 F</i>	150
<i>04 F</i>	150
<i>05 F</i>	152
<i>07 F</i>	154
<i>I_n F</i>	141
2 wires	76, 108
4 wires	108
Actual load calibration.....	21
ALARM 1	70
ALARM 2	70
Analog output.....	114, 154
Auto print mode	78, 98, 105
Automatic mode	27, 135
Backup method	155
Backuperd RAM	73
Baud rate	76, 98, 108, 111
BCD output	103, 148, 149
BCD terminals.....	104
Calibration.....	21
Capacity.....	15, 21
Category address	124, 125
CERR1	25
CERR10	25
CERR11	25
CERR2	14, 25

CERR3	14, 25
CERR4	25
CERR6	25
CERR7	25
CERR8	25
CERR9	25
CL F.....	146
Code	
Average	43
Code	43
Crush#	43
Duplication#	43
FMD#	43
Full	43
Hi	43
Hi#	43
HiHi	43
HiHi#	43
Lo	43
Lo#	43
LoLo	43
LoLo#	43
Max	43
Min	43
Name	43
NG#	43
OK#	43
PT	43
STD	43
STDP	43
Target	43
Tgt#	43
Tot#	43
Total	43
Zero Band	43
σ _n	43
σ _{n-1}	43
Code data.....	156
Command mode	78
Communication modes	78
Control I/O terminal.....	11
Conveyor	27, 29
Conveyor stop mode.....	29, 135
Cursor	17
Data length	76, 98, 108, 111
Decimal point	21
Digital span	21
Division	21

EMC.....	5	SHIFT key.....	9, 17, 18, 115
Emergency stop mode.....	20	START key.....	9
Error code.....	25	STOP key.....	9
EXC-.....	14	Tare key.....	9
EXC+.....	14	ZERO key.....	9
FCC.....	5	Loadcell.....	11, 14, 15
Flash memory.....	73	Loadcell excitation voltage.....	155
FULL.....	50	Loss-in-weigh.....	135
Fuse.....	7	Main power switch.....	11
G1.....	24	Manual mode.....	35, 135
$\bar{U}EnF$	127	Manual print mode.....	78, 98, 105
Graphic indicator.....	68, 72	Mass.....	21
Gravity acceleration correction.....	21	Maximum display.....	155
Gross.....	63, 64	Measuerment range.....	155
I/O terminals.....	112	Menu.....	19
Indication items.....	65	Mode map.....	19
Indicator		Monitor mode.....	115
0. BAND, Zero band.....	10	Net.....	63, 64
ALARM 1.....	10	OFF.....	17
ALARM 2.....	10	OK mode.....	33, 135
BUSY.....	10	ON.....	17
CZ.....	10	Operation mode.....	20
D.COMP.....	10, 53	$o\bar{t}hF$	133
Hi.....	11, 68	$\bar{O}utF$	142
HiHi.....	68	Output terminals.....	74
Lo.....	11, 68	Panel cutout size.....	13
LoLo.....	68	Parallel I/O.....	152
OK.....	11, 68	Parameters.....	124
Operate.....	10	Parity bit.....	76, 98, 108, 111
SQ.ERR.....	10	Pause.....	20
ZR.ERR.....	10	Power consumption.....	155
ZTR.....	10	Power cord.....	7
Input terminals.....	74	Power source.....	16, 155
Intialization.....	121	Preset tare.....	64
IP-65.....	6, 13	Relay output.....	107
Item number.....	124	$r\bar{S}F$	144
Jet steam mode.....	78, 105	RS-232C.....	98, 111, 150
Judgement.....	52	RS-422.....	108, 150
Key		RS-485.....	11, 76, 108, 150
$\bar{\nabla}$ key.....	9, 17, 115	Safety check.....	61
ENTER key.....	17, 18, 22, 23, 115	Sampling rate.....	155
A/a key.....	9, 17	Selector.....	27, 29, 52
Alphabetical keys.....	9, 17, 115	SEN-.....	14
Buzzer key.....	9	SEN+.....	14
CLEAR TOTAL key.....	9	Sensitivity.....	15, 155
CODE RECALL key.....	9, 18	Setpoint.....	6, 37
CODE SET key.....	9	Simple mode.....	37, 135
ENTER key.....	9	Span calibration.....	21
ESC key.....	9, 17, 18, 22, 23, 70, 115	$S\bar{9}F$	135
F1 key.....	9, 133	SQ.ERR.....	61, 70
F2 key.....	9, 133	SQ.ERR2.....	56
Numerical keys.....	9, 18	SQ.ERR6.....	56

Standby mode.....	19	Test mode.....	118
Start bit	76, 98, 108, 111	Total print mode.....	78
Stop bits.....	76, 98, 108, 111	Unit	21
Stop mode	20	VFD	6
Stream mode	78, 98, 105	Water-resistant panel.....	6
Sub-display	65	Weighing status	72
<i>SUBF</i>	129, 132	Weight	21
Summing box.....	21	Zero calibration.....	21
Tare	63	Zero display	50, 62
Temperature	155	Zero point adjustment.....	14, 21
Terminal E	16	Zero range	155
Terminal parts.....	14, 16	Zero tracking.....	50, 51
Terminator	76, 108	ZR. ERR.....	62, 70



A&D COMPANY, LTD.

3-23-14 Higashi-Ikebukuro, Toshima-ku, Tokyo 170-0013, JAPAN
Telephone: [81] (3) 5391-6132 Fax: [81] (3) 5391-1566

A&D ENGINEERING, INC.

1756 Automation Parkway, San Jose, California 95131, U.S.A.
Telephone: [1] (408) 263-5333 Fax: [1] (408)263-0119

A&D INSTRUMENTS LIMITED

Unit 24/26 Blacklands Way, Abingdon Business Park, Abingdon, Oxfordshire OX14 1DY United Kingdom
Telephone: [44] (1235) 550420 Fax: [44] (1235) 550485

A&D AUSTRALASIA PTY LTD

32 Dew Street, Thebarton, South Australia 5031, AUSTRALIA
Telephone: [61] (8) 8301-8100 Fax: [61] (8) 8352-7409

A&D KOREA LTD.

한국에이.엔.디(주)

서울특별시 영등포구 국제금융로6길33 (여의도동) 맨하탄빌딩 817 우편 번호 07331
(817, Manhattan Bldg., 33. Gukjegeumyung-ro 6-gil, Yeongdeungpo-gu, Seoul, 07331 Korea)
전화: [82] (2) 780-4101 팩스: [82] (2) 782-4264

OOO A&D RUS

ООО "ЭЙ энд ДИ РУС"

121357, Российская Федерация, г.Москва, ул. Вереysкая, дом 17
(Business-Center "Vereyskaya Plaza-2" 121357, Russian Federation, Moscow, Vereyskaya Street 17)
тел.: [7] (495) 937-33-44 факс: [7] (495) 937-55-66

A&D INSTRUMENTS INDIA PRIVATE LIMITED

ऐ&डी इन्स्ट्रूमेन्ट्स इण्डिया प्रा० लिमिटेड

509, उद्योग विहार , फेस -5, गुडगांव - 122016, हरियाणा , भारत
(509, Udyog Vihar, Phase-V, Gurgaon - 122 016, Haryana, India)
फोन : 91-124-4715555 फैक्स : 91-124-4715599