

AD-4430C



for CC-Link

DIN Rail Weighing Module

INSTRUCTION MANUAL

The manual and Marks

All safety messages are identified by the following, "WARNING" or "CAUTION", of ANSI Z535.4 (American National Standard Institute: Product Safety Signs and Labels). The meanings are as follows:

 WARNING	A potentially hazardous situation which, if not avoided, could result in death or serious injury.
 CAUTION	A potentially hazardous situation which, if not avoided, may result in minor or moderate injury.



This is a hazard alert mark.

- This manual is subject to change without notice, at any time, to improve the product.
- The contents of the product specifications and this manual are subject to change without any obligation on the part of the manufacturer.
- Under the copyright laws, the software (program) described in this manual is copyrighted, with all rights reserved.
The software may be installed into one computer and may not be installed into other computers without the prior written consent of A&D Company, Limited. Copying includes translation into another language, reproduction, conversion, photocopying and offer or loan to another person.

Teflon is a registered trademark of DuPont.

© 2015 **A&D Company, Limited** All rights reserved.

No part of this publication may be reproduced, transmitted, transcribed, or translated into any language in any form by any means without the written permission of A&D Company, Limited.

Contents

1.	Compliance.....	5
1.1.	Compliance with FCC rules.....	5
1.2.	Compliance with European Directives	5
1.3.	Precautions for Safety Use.....	5
2.	Outline and Features	6
3.	Specifications	7
3.1.	Analog Part (Load cell Input, A/D Converter)	7
3.2.	Digital Part (Display and Keys).....	7
3.3.	General.....	7
3.3.1.	Interface.....	7
3.3.2.	Weighing Function.....	8
3.3.3.	General.....	8
3.3.4.	Accessories	8
3.3.5.	Dimensions.....	9
3.4.	Names (The Front Panel and Rear Panel)	10
4.	Installing the Module.....	11
4.1.	Conditions to Install the Module	11
4.2.	Power Supply	11
4.3.	Connecting Load Cell Cable.....	12
4.4.	Verifying Load Cell Cable	13
5.	Operations	14
5.1.	General Functions	14
5.1.1.	Zero Operation	14
5.1.2.	Zero Tracking.....	14
5.1.3.	The Tare Function.....	14
5.1.4.	Customizing the Function of the F Switch.....	15
5.1.5.	Customizing the Function of the x Display	16
5.1.6.	Memory Backup	16
5.1.7.	The Detection for the Near-Zero	16
5.1.8.	Upper or Lower Limit Detection Function.....	16
5.1.9.	Full Value Detection Function.....	17
5.1.10.	User I/O (Remote I/O).....	17
5.1.11.	The Hold Function.....	18
5.2.	State Diagram And Operation Switches.....	19
5.2.1.	State Diagram.....	19
5.2.2.	Operation Switches	20
5.3.	The Calibration	21
5.3.1.	Outline of the Calibration	21
5.3.2.	The Calibration using Actual Load ($L-SEt$)	22
5.3.3.	Gravity Acceleration Correction.....	23
5.3.4.	The Linearization Function	24
5.3.5.	The Actual Load Linearization Function ($L-SEt$)	25
5.3.6.	The Function Related to the Calibration ($L-Fnc$).....	26
5.3.7.	The Function Related to the Linearization Function ($L-Fnc$).....	30

5.3.8.	Error Codes for the Calibration (ERR)	31
5.3.9.	Adjustment of the Load Cell Output	31
5.4.	The List of General Functions	32
5.4.1.	The Procedure to Store New Parameters	32
5.4.2.	The Adjustment of the Digital Filter.....	33
5.4.3.	The Use of the Second Digital Filter.....	33
5.4.4.	The Function Related to the Basics Function (FUNC).....	34
5.4.5.	The Function Related to the Hold Function (HOLD).....	35
5.4.6.	The Function Related to the Weighing Sequence Program (SEQ).....	36
5.4.7.	The Function Related to the Setpoint (SP).....	37
5.4.8.	The Function Related to the Control I/O (IO).....	38
5.4.9.	The Function Related to the Standard Serial Output (L).....	39
5.4.10.	The Function Related to the CC-Link (CC).....	39
5.5.	Weighing Sequence	40
5.5.1.	Normal Batch Sequence	40
5.5.2.	Loss in Weight Sequence.....	42
5.5.3.	Automatic Free Fall Correction.....	44
5.5.4.	Active Free Fall Compensation	44
5.6.	Setpoint (Comparator value)	44
6.	Interface	45
6.1.	Control I/O	45
6.2.	Serial Output (Current Loop)	46
6.2.1.	Data format of Serial Output.....	47
6.2.2.	Transfer Mode of Serial Output	48
6.3.	The CC-Link	49
6.3.1.	Address Map	50
6.3.2.	Commands	58
6.3.3.	Timing Chart	59
6.3.4.	The Calibration	61
6.3.5.	Self-Check	62
6.3.6.	Function Settings.....	62
6.4.	USB (RS-232C).....	63
6.4.1.	Format	63
6.4.2.	Monitoring the Function Setting.....	63
6.4.3.	Storing the Function Setting	64
6.4.4.	Monitoring the Whole Function Settings	64
6.4.5.	Monitoring Each Piece of Data.....	64
7.	Maintenance	65
7.1.	Error Messages	65
7.2.	Verifying the Load Cell Connections (DIAGNOS).....	65
7.2.1.	Guideline to Verify the Load Cell Connections.....	65
7.2.2.	Verifying Load Cell Connections with Switch Operation	66
7.2.3.	Verifying Load Cell Connections with the CC-Link.....	66
7.2.4.	Verifying Using the Control I/O	66
7.2.5.	Display and Output of Verification	67
7.3.	Check Mode	68
7.3.1.	Entering to the Check Mode.....	68

7.3.2.	Verifying the Switch Operation	68
7.3.3.	Checking the Control I/O	68
7.3.4.	Checking the Serial Communication	68
7.3.5.	Checking the CC-Link	69
7.3.6.	Monitoring the A/D Converter (for Load Cell Output)	69
7.3.7.	Monitoring the Internal Value.....	69
7.3.8.	Monitoring the Program Version.....	69
7.3.9.	Monitoring the Serial Number.....	69
7.3.10.	Monitoring the Checksum of the Program	69
7.3.11.	Monitoring the Checksum of an Internal FRAM.....	69
7.3.12.	Displaying Function Parameters for the Calibration	69
7.4.	Initializing Parameters	70
7.4.1.	Initializing Mode for RAM and Function Parameters.....	70
7.4.2.	Initializing the Whole Data	70
7.5.	Verifying the Load Cell Connections Using Multimeter	71
7.5.1.	Check List of the Load cell Connections	71
7.6.	The Parameter List For The Function	73
7.6.1.	The Function Related to the Calibration ($L-F_{nc}$).....	73
7.6.2.	The Function Related to the Linearization Function ($L-F_{nc}$).....	74
7.6.3.	The Function Related to the Basics Function ($F_{nc} F$).....	75
7.6.4.	The Function Related to the Hold Function ($HLd F$).....	77
7.6.5.	The Function Related to the Weighing Sequence Program ($S^q F$).....	78
7.6.6.	The Function Related to the Setpoint ($S^P F$).....	79
7.6.7.	The Function Related to the Control I/O ($IO F$).....	80
7.6.8.	The Function Related to the Standard Serial Output ($EL F$).....	81
7.6.9.	The Function Related to the CC-Link ($EL F$).....	82

Illustrations

Illustration 1	Dimensions	9
Illustration 2	Front panel & rear panel	10
Illustration 3	Mounting the module	10
Illustration 4	Cables	11
Illustration 5	Load cell connections (6-wire connection).....	12
Illustration 6	Load cell connections (4-wire connection & direct connection).....	13
Illustration 7	Peak hold / Averaging hold	18
Illustration 8	State diagram	19
Illustration 9	Gravity acceleration graph	24
Illustration 10	Digital linearization	24
Illustration 11	Load cell output adjustment.....	31
Illustration 12	The second digital filter	33
Illustration 13	Normal batch sequence.....	40
Illustration 14	Loss in weight sequence	42
Illustration 15	The CC-Link connector	49
Illustration 16	Turning on the display	59
Illustration 17	Requesting initialization from master station	59
Illustration 18	Inputting setpoints (Basic comparator parameters)	60
Illustration 19	Reading command.....	60
Illustration 20	Writing command	60
Illustration 21	Monitoring the CPU signal	61
Illustration 22	Resetting error status flag.....	61
Illustration 23	Wire name of load cell	65
Illustration 24	Connection check of load cell	71

1. Compliance

1.1. Compliance with FCC rules

- Please note that this equipment generates, uses and can radiate radio frequency energy. This equipment has been tested and has been found to comply with the limits of a Class A computing device pursuant to Subpart J of Part 15 of FCC rules. These rules are designed to provide reasonable protection against interference when this equipment is operated in a commercial environment. If this unit is operated in a residential area it may cause some interference and under these circumstances the user would be required to take, at his/her own expense, whatever measures are necessary to eliminate the interference. (FCC = Federal Communications Commission in the U.S.A.)

1.2. Compliance with European Directives

- ☒ This appliance complies with the statutory EMC (Electromagnetic Compatibility) directive 2004/108/EC and the Low Voltage Directive 2006/95/EC for safety of electrical equipment designed for certain voltages.

Note: The displayed value may be adversely affected under extreme electromagnetic influences.

1.3. Precautions for Safety Use

Before use, confirm the following articles for safe operation.

- **Grounding the Module**
Ground the module to the DIN rail certainly. Separate this earth ground line from others, such as ground lines for the motor, inverter or power source. Unless the indicator is grounded, it may result in electric shock, operation error or fire.
- **Proper Power Source and Power Cable**
Confirm the AC voltage, frequency and power tolerance of the power cable. If the voltage range of the cable is lower than the power line voltage, it may cause leakage or catch fire. Use pole compression terminals to connect the power cable to the terminals.
- **Fuse**
The fuse is installed to help prevent the module from catching fire. The module is equipped with many safety circuits, so if the internal circuits are functioning properly, the fuse is not damaged. If the fuse is damaged, do not replace it but contact your local A&D dealer. This may have been caused by strong electric discharge.
- **Splashing Water**
The module is not water resistant.
- **Flammable Gas**
Do not install the module where flammable gas is present.
- **Heat Radiation of the Module**
Space out instruments to radiate heat sufficiently. Use a cooling fan to keep the operating temperature of the module within specifications.

2. Outline and Features

The AD-4430C has the following features.

- The AD-4430C is a weighing indicator that amplifies signals from a load cell, converts it to digital data and displays it as a mass value.
- The CC-Link communication
When connected to the CC-Link (Control & Communication Link) which makes seamless data communication possible, the weighing system can be built on the network, enhancing flexibility and convenience compared to the conventional communication connections.
 - The calibration can be performed using the command of the CC-Link.
 - Monitoring and changing of functions can be performed.
 - Up to 42 indicators can be connected to one master device when multiple AD-4430C are only used.
- Remote I/O function (User I/O)
The remote I/O is a function for the user's arbitrary application to use the control I/O terminals as the remote I/O. External sensors and switches can be monitored and controlled.
- This indicator has the following performance :
 - Input sensitivity 0.15 $\mu\text{V}/\text{d}$ (d = minimum division)
 - Display resolution 99,999 d in maximum
 - Sampling rate 1000 times/second
 - Input voltage range -35 to +35 mV (-7 to +7 mV/V)
- The calibration using gravity acceleration correction
The function compensates for weighing error due to the difference of gravity acceleration between the calibration place and the measurement place.
- The digital linearization function
The digital linearization function can rectify and reduce the deviation using weighing points during the zero and maximum capacity. Up to four weighing points excluding zero point can be specified. The high-order correction curve is used between each point.
- The digital span mode
Simplified calibration is possible using numerical input, even without an actual load.
- Weighing sequence
The AD-4430C can use a normal batch and loss in weight.
- Dual digital filter (2nd D.F.)
The AD4430C is equipped with a second digital filter that can respond at the same time and is separated form basic weighing. Refer to "5.4.3. The Use of the Second Digital Filter" for details.
- Flow rate (change volume)
The AD4430C can display the current flow rate (change rate) every second.

3. Specifications

3.1. Analog Part (Load cell Input, A/D Converter)

Input sensitivity	0.15 $\mu\text{V}/\text{d}$ or greater (d = minimum division)	
Input voltage range	-35 mV to +35 mV (-7 to +7 mV/V)	
Zero range	-35 mV to +35 mV (-7 to +7 mV/V)	
Load cell excitation voltage	5 VDC $\pm 5\%$, 60 mA with remote sense capability (Maximum 4 x 350 Ω load cells)	
Temperature coefficient	Zero	$\pm 0.02 \mu\text{V}/^\circ\text{C}$ Typ. $\pm 0.1 \mu\text{V}/^\circ\text{C}$ max
	Span	$\pm 3 \text{ ppm}/^\circ\text{C}$ Typ. $\pm 15 \text{ ppm}/^\circ\text{C}$ max
Non-Linearity	0.005% of full scale	
A/D conversion method	Delta-sigma method	
A/D resolution count	Approximately 16,000,000 counts	
Display resolution	99,999 d max. (d = minimum division)	
Sampling rate	1000 times/second	

3.2. Digital Part (Display and Keys)

Display element	Measurement display	5-digit 7-segment red LED
	Status indicators	6 red LEDs
Measurement display	Numerical display	Switches between NET and GROSS
	Decimal point	Selectable decimal places (10 ¹ , 10 ² , 10 ³ , 10 ⁴)
	Overflow display	All the digits turn OFF. (When the polarity is negative, the minus sign appears at the highest-order digit.)
Status indicators	G: GROSS, N: NET, H: HOLD, S: STABLE, Z: ZERO, X: Preset function selected from the function list.	
Key switches	F/ESC, \rightarrow (ZERO), \uparrow (TARE), ENT	

3.3. General

3.3.1. Interface

Control I/O	Input : Photo coupler	6ch	MDR connector 20 pins female
	Output : Open collector type	8ch	
Serial data output	Output for A&D peripherals 20 mA current loop		
CC-Link	Ver. 1.10	Remote device station	Power clamp connector (3M)
USB	—		USB 2.0 Micro-B female

3.3.2. Weighing Function

Zero operation	Sets the gross weight to zero by pressing the →(ZERO) key. Selection of disable or enable for the operation when unstable. The zero value is stored in the nonvolatile memory (FRAM). Zero adjustable range : Can be set optionally in the range of 1 to 100% of the maximum capacity.
Zero tracking	Tracks the weight drift around the zero point to maintain zero. Zero tracking time : 0.0 to 5.0 sec. Can be set optionally within the range Zero tracking band : 0.0 to 9.9 d Can be set optionally within the range
Tare	Sets the net weight to zero by pressing the ↑(TARE) key. The inhibition / permission switch of the tare function can be used when the weighing value is unstable and negative. The tare value is stored in the nonvolatile memory (FRAM). Tare range : Gross weight ≤ Maximum capacity
Stability detection	Turns ON the stabilization indicator S when the variation amount of the weight values per sampling are within the set band in the set time. Detection time : 0.0 to 9.9 sec. Can be set optionally within the range Detection band : 0 to 9d Can be set optionally within the range
Digital filter	Cutoff frequency (-3 dB) range : 0.7 to 100 Hz
2nd digital filter	Cutoff frequency (-3 dB) range : 0.07 to 100 Hz
Zero detection	Non loading can be detected as near-zero and it is output.
Comparator	Compares the measurement with HI/OK/LO limits and outputs the results.
Hold function	Displays the measurement value held. Select from sample hold, peak hold, average hold.
Weighing sequence function	Normal batch, Loss in weight.

3.3.3. General

Data backup, power failure countermeasure	Zero value, tare value, calibration, function parameters are backed up using by FRAM. (Approx. 10 years)
Power source	DC 24 V, +10%, -15%
Power consumption	Approximately 6 W
Operating temperature Operating humidity	-10 °C to +50 °C, 85 %RH or less (no condensation)
Installation method	DIN rail mount
Mass	Approximately 200 g

3.3.4. Accessories

Item	Quantity	Model name
CC-Link connector	1	Power clamp wire mount socket, 3M, 35505-6000-B0M GF

3.3.5. Dimensions

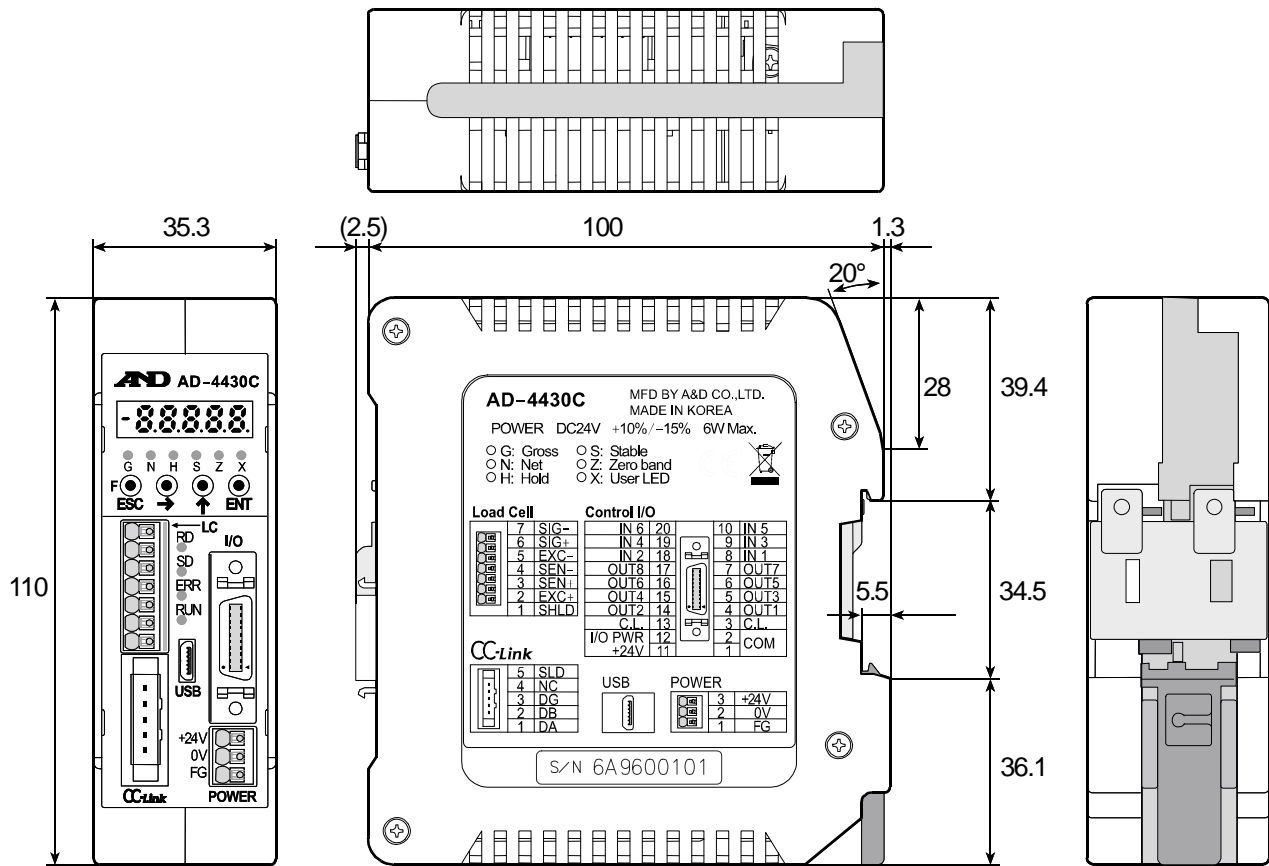

Unit : mm

Illustration 1 Dimensions

3.4. Names (The Front Panel and Rear Panel)

Illustration 2 Front panel & rear panel

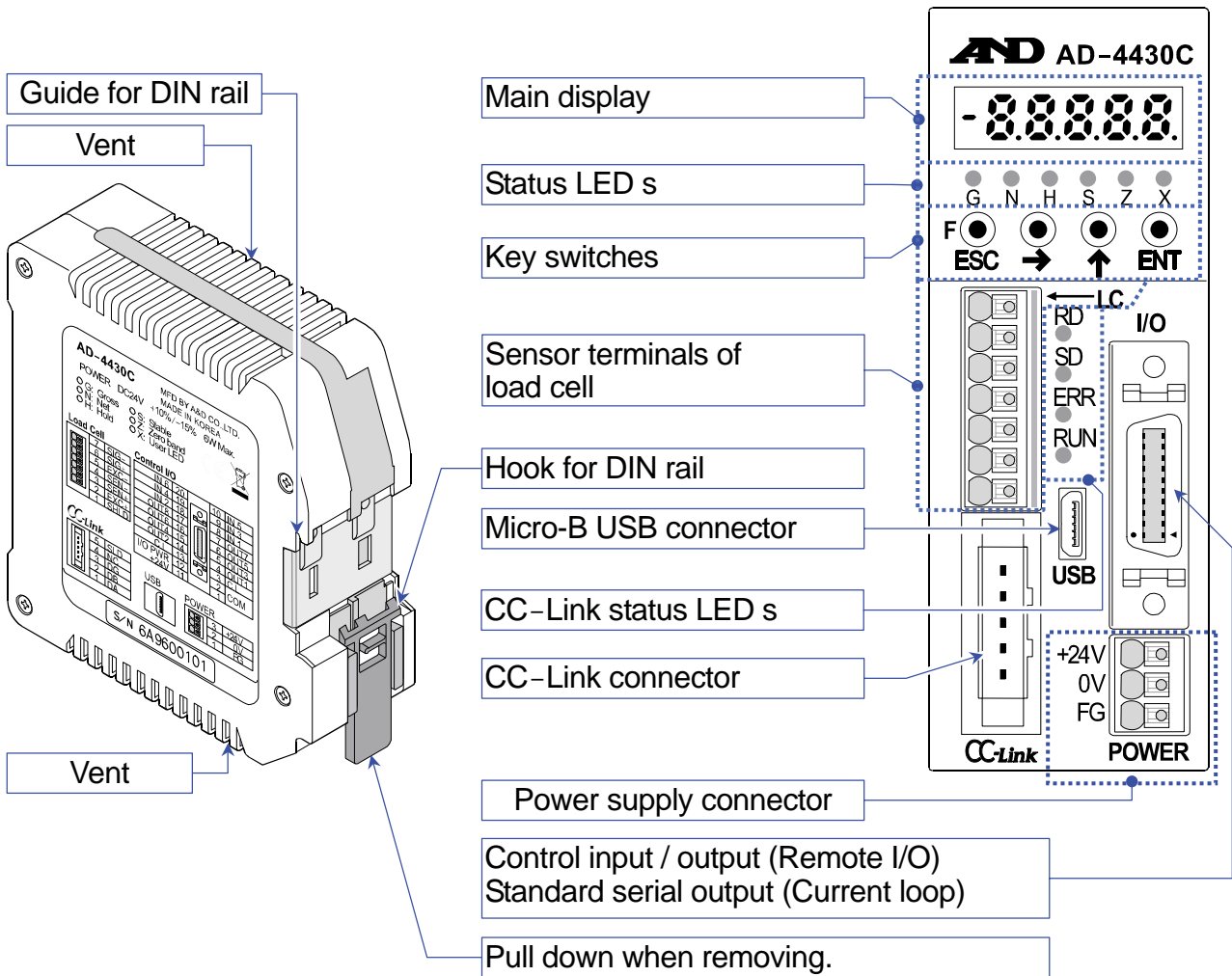
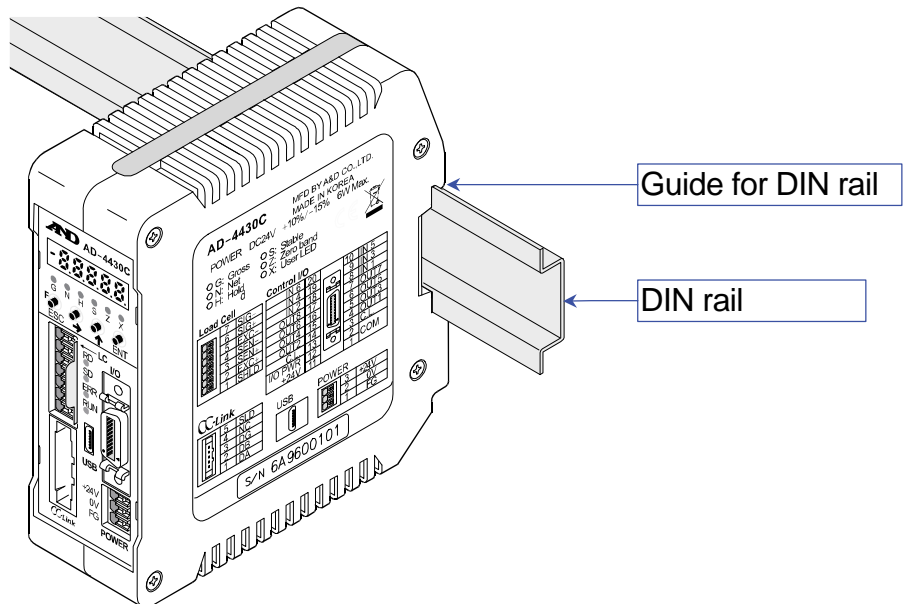

Illustration 3 Mounting the module



4. Installing the Module

In this section, installation environment, power terminal and load cell cable, and how to connect them are explained. Refer to each chapter for other external I/O.

4.1. Conditions to Install the Module

- The module is a precision electronic instrument. Handle it carefully.
- The operating temperature is $-10\text{ }^{\circ}\text{C}$ to $+50\text{ }^{\circ}\text{C}$.
- Do not install the module in direct sunlight.

4.2. Power Supply

⚠CAUTION

- Earth ground the module to prevent electrical shock or indicator malfunction.
If the module is not grounded, it may cause of an electric shock, or malfunction due to static electricity.

- Before connecting the module to the power source, read the instruction manual thoroughly.
- Do not connect the module to the power source before the installation is complete.
- ⚠□ To avoid electrical shock, do not handle the power cable with wet hands.
- ⚠□ Earth ground the module. Do not share the ground line with other electrical power equipment.
- The power requirement is 24 DCV, $+10\%$ to -15% .
Use a stable power source free from instantaneous power failure or noise.
- To avoid a malfunction, do not share the power line with other devices.
- The output voltage of a load cell is a very sensitive signal. Keep all electrical noise sources away from the load cell and load cell cable.
- Use cables shielded for input and output. Connect the cable shield to the F.G. terminal or the module housing.

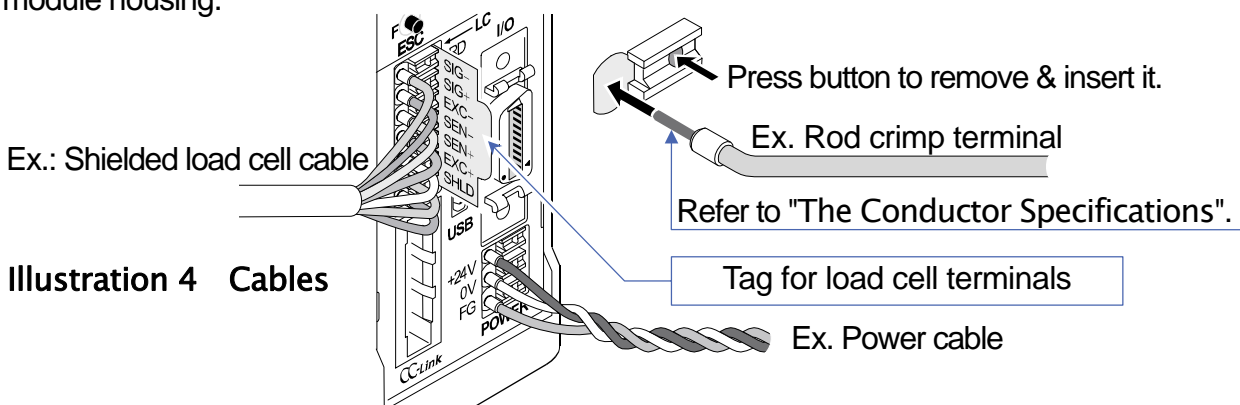

Illustration 4 Cables

The Conductor Specifications

Clamp range (typ.)		0.13 mm ² to	1.5 mm ²
AWG		AWG24 —	AWG16
Solder plated wire		0.2 mm ² to	1.5 mm ²
Twisted wire		0.2 mm ² to	1.5 mm ²
Rod crimp terminal	DIN 46228 Part1	0.25 mm ² to	1.5 mm ²
Rod crimp terminal with cover	DIN 46228 Part4	0.25 mm ² to	0.75 mm ²
Lead length		8 mm	

4.3. Connecting Load Cell Cable

Load Cell

- The cable that extends from the load cell is a part of the load cell. Do not cut the load cell cable even if there is the remainder of the cable.
- Bundle the load cell cable if there is the remainder of the cable.
- The load cell is compensated for temperature change including the resistance value of this cable.
- Basically, connect the shield wire to a point of the shield terminal of the AD-4430C and do not ground it. If there are multiple ground points, it may result in noise due to a ground loop.

Remote Sensing (Compensation for length of the extension cable)

- The AD-4430C is equipped with the compensation function that monitors a drop voltage for the excitation voltage and rectifies the A/D conversion value.
- Use the 6-wire extension cable to use the remote sensing function for the load cell.
- Connect terminals of SEN+ and SEN-. If they are not connected, measurements cannot be performed.
- When the 4-wire cable is used, connect terminals of EXC+ and SEN+ and terminals of EXC- and SEN- at the load cell terminal of the AD-4430C.

Load Cell Cable

- Load cell cables should have high electrical insulation and shield performance.
- Use shielded cables with the insulator that is made of materials with high insulation resistance such as Teflon and polyethylene. **NOTE: Teflon is a registered trademark of DuPont.**
- We recommend using the load cell extension cable produced by A&D co., ltd. when using it. AX-KO162-5M to 100M (5m to 100m)

Cable diameter.....φ9 mm

Cross-sectional area of the conducting wire0.5 mm², 6-wire cable equipped

Terminal No.	Terminal name & Function of the AD-4430C	
7	SIG-	Load cell input (-)
6	SIG+	Load cell input (+)
5	EXC-	Load cell excitation voltage (-)
4	SEN-	Sensing input (-)
3	SEN+	Sensing input (+)
2	EXC+	Load cell excitation voltage (+)
1	SHLD	Shield

6-wire connection to load cell (Recommended)

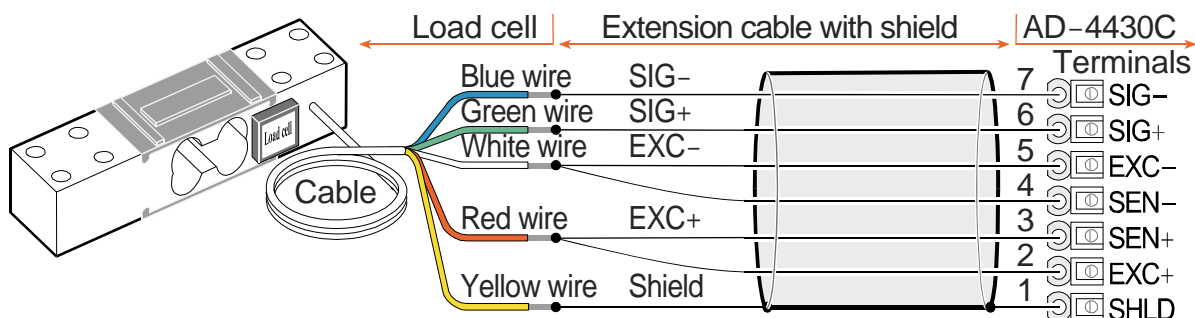
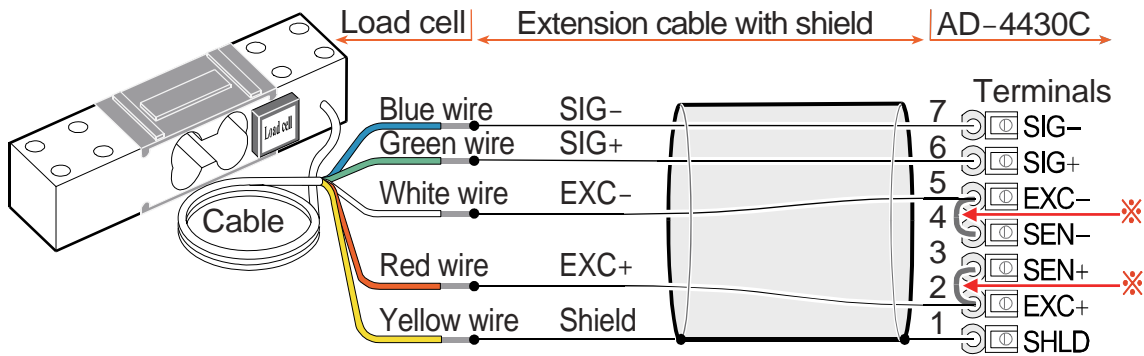

Illustration 5 Load cell connections (6-wire connection)

4-wire connection to load cell



Direct connection to load cell

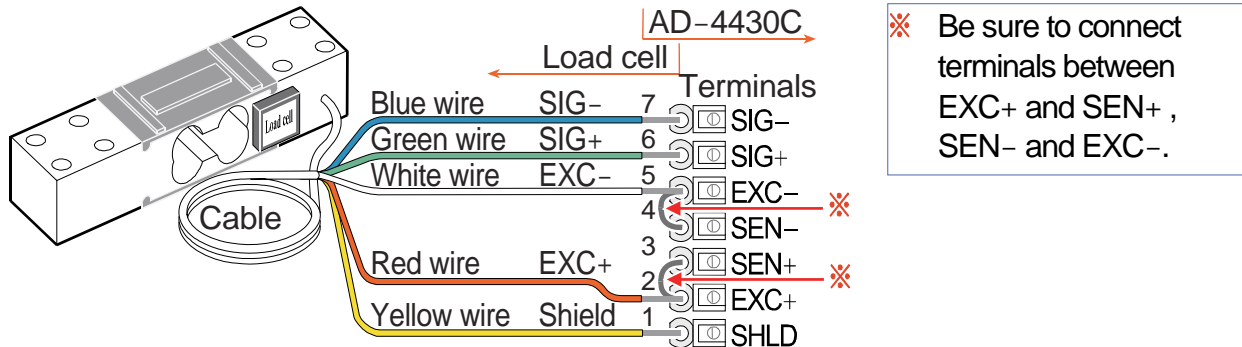

Illustration 6 Load cell connections (4-wire connection & direct connection)

4.4. Verifying Load Cell Cable

When the load cell connection is complete, perform a connection check using the following procedure.

- Perform a visual check to ensure that the wiring is correct.
- Turn the module on.
When the calibration has not yet been carried out, the indication value may be blank. However, as long as there are no problems with the display, confirmation can still be carried out using the check mode.
- Enter to the check mode and check the load cell output value.
Refer to "7.3.Check Mode" to enter to the A/D check mode.
- Confirm that the displayed load cell output value matches the specified value. Normally the displayed value will be the load cell rated output value or less.
- If an error occurs, refer to "7.2. Verifying The Load Cell Connections (DIAGNOS)" or "7.5. Verifying The Load Cell Connections Using Multimeter".

5. Operations

5.1. General Functions

5.1.1. Zero Operation

- Zero operation is a function to set the gross weight to zero. It is performed by pressing the **→(ZERO)** key.
- The zero range is set in **C-F05** (Zero range) and is expressed in percent of the maximum capacity with the calibration zero point as the center.
- Zero operation is disabled, even within the zero range, when the A/D converter overflow occurs.
- A ZERO error is output if zero operation is not performed when the value is unstable or out of range.
- The zero value is stored in the non-volatile memory and is maintained, even if the power is disconnected.
- Clearing the zero value is performed using the **F** key assigned to clear the zero value.
- **Functions Related to Zero Operation**
 - **C-F05** (Zero range) : A value between 0% and 100% can be specified.
 - **C-F10** (Tare and zero at unstable weight value) : The selection to enable or disable tare and zero operation when unstable.
 - **C-F16** (Zero setting when power is turned on) : The selection whether or not to perform zero setting when power is turned on.

5.1.2. Zero Tracking

- The zero tracking function traces the gross weight drift around the zero point to maintain zero.
- The zero tracking time is set in **C-F06** (Zero tracking time) and the zero tracking band is set in **C-F07** (Zero tracking band). When the gross weight drift is within the specified ranges, zero tracking is performed automatically.
- A ZERO error is not output even if zero tracking is not performed.
- **Functions Related to Zero Tracking**
 - **C-F06** (Zero tracking time) : The value between 0.0 and 5.0 seconds can be specified.
 - **C-F07** (Zero tracking band) : The value between 0.0 and 9.9 d can be specified. (d = minimum division)

5.1.3. The Tare Function

- Tare is a function to store the gross weight as the tare value and set the net weight to zero. It is performed by pressing the **↑(TARE)** key.
- The tare value is stored in the non-volatile memory and is maintained, even if the power is disconnected.
- Clearing the tare value is performed using the **F** key assigned to clear the tare value.
- **Functions Related to the Tare Function**
 - **C-F10** (Tare and zero at unstable weight value) : The selection to enable or disable tare and zero operation when unstable.
 - **C-F11** (Tare when the gross weight is negative) : The selection to enable or disable tare when the gross weight is negative.

Clearing the Tare Value and Zero Operation

The way to clear the tare value and zero operation : While pressing and holding the **↑(TARE)** key, turn on the module.

Another way : In the off mode, while pressing and holding the **↑(TARE)** key, press the **ENT** key.

5.1.4. Customizing the Function of the F Switch

- Assign a function to the **F** key in the general functions.
- **Functions Related to the F Key**
 - Assigns a function to the **F** key from the functions of **Fnc02** (**F** key) below :

0: None	7: Zero clear
1: Manual print command	8: Batch start / Pause / Re-start
2: Hold	9: Actual free fall input
3: Alternative switch (Active F key)	10: One shot, Small flow
4: Momentary switch (Active F key)	11: Flow rate monitor (Change volume)
5 : Display exchange	12: mV/V monitor
6: Tare clear	13: Second digital filter (2nd D.F.)

5 means factory settings.
 - **C-F15** (Clear the zero value) : The selection to enable or disable clearing the zero value.

Alternate switch and momentary switch

By assigning these switches to the **F** key, the ON/OFF status of the **F** key can be transmitted to the master station. This is useful when building a network or performing maintenance. When "Active **F** key" is specified to the function of the display x, the operation of the **F** key can be monitored by the display x. These switches work as follows :

Alternate switch

When pressing and releasing the switch once, the state of the switch is maintained. Press the switch again to turn off or on.

Momentary switch

Only while the switch is being pressed, the switch is ON. When it is released, it is OFF.

Additional monitor

For confirmation, the AD-4430C can display weighing data or other data. The decimal point of other data is flashed to separate weighing data, both LEDs of G: gross and N: Net are lit. When pressing the **F** key again, the AD-4430C returns to weighing mode.

Flow rate (Change rate)	Flow rate (Change rate) per second.
mV/V	Output voltage of load cell in the unit of mV/V.
Second digital filter	Response of weighing data by 2nd digital filter

5.1.5. Customizing the Function of the x Display

- Assign a function to the x display in the general functions.
 - **Functions Related to the Display x**
 - Assigns a function to the x display from the functions of **Fnc04** (x display) below :

0: None	11: Over
1: Zero tracking in progress	12: OK
2: Alarm (Zero range setting error, over)	13: Under
3: Active <input type="checkbox"/> key	14: Full value
4: Near-zero	15: Weighing sequence, finished
<input type="checkbox"/> : HI output (Over the upper limit value)	16: Weighing sequence, in processing
6: OK output (Between upper and lower limit values)	17: Weighing sequence, error
7: LO output (Below the lower limit value)	18: Normal batch / Loss-in weight, Identification (ON = Loss-in weight)
8: Large flow	19 to 24: User input1 to 6
9: Medium flow	25 to 32: User output 1 to 8
10: Small flow	
- means factory settings.

key status
When alternate switch or momentary switch is selected at **Fnc02**, the works.
The display turns ON when the key is ON and turns OFF when the key is OFF.

5.1.6. Memory Backup

- Zero value, tare value, calibration data and function data are written into non-volatile memory (FRAM). The FRAM does not require batteries. The data retention period is 10 years. Therefore, this module is not equipped with a backup battery.

5.1.7. The Detection for the Near-Zero

- Near-zero is a function to detect whether an object has been placed on the weighing pan. Near-zero is defined as a state of the near-zero when the weighing value is within the preset value for the near-zero.
- **Functions Related to the Near-Zero**
 - **Fnc08** (Set value of near-zero) : The value of near-zero can be specified.
 - **Fnc09** (Comparison mass at near-zero) : The selection of the gross weight or net weight to compare the value of near-zero.

5.1.8. Upper or Lower Limit Detection Function

- This is a function to detect whether the weighed value is above an upper limit value or below a lower limit value.
- **Functions Related to the Detection Function**
 - **Fnc10** (Upper limit value) or **Fnc11** (Lower limit value) : A comparative upper or lower limit value can be set.
 - **Fnc12** (Comparison mass of upper and lower limit) : Gross weight or net weight to be compared with the upper or lower limit value can be selected.

5.1.9. Full Value Detection Function

The full value detection is a function to detect that weighing value has reached the maximum value. The status of the full value is when gross weight is above the preset full value.

□ **Functions Related to the Detection Function**

- **Fnc13** (Full value) : A comparative value of the full value can be preset.

5.1.10. User I/O (Remote I/O)

User I/O (user input and user output) can be used for the user's arbitrary application and is not directly related to the weighing system. Therefore it can turn on the control output using a command on the interface and can check the state of the control input terminal.

□ **Example 1. of Use**

We want to monitor a photo sensor using the PLC, but, there is not an input port.

- Assign a control input terminal to user input. Connect a photo sensor to this terminal.
- Monitor this terminal connected to the photo sensor using user I/O of the CC-Link.

□ **Example 2. of Use**

We want to control a relay using remote operation by the PLC, but, there is no output port.

- Assign a control output terminal to user output. Connect a relay to this terminal.
- Control this terminal connected to relay using user I/O of the CC-Link.

□ **Example 3. of Use**

We want to monitor a controlled relay by the PLC on the front panel of the AD-4430C.

- Assign a control output terminal to user output. Connect a relay to this terminal.
- Assign a monitored output terminal to the display x.

5.1.11. The Hold Function

- There are three types of hold functions which can be used for different purposes.
- **Normal hold**
The normal hold function holds the value displayed at the time the hold command was received.
- **Peak hold**
The Peak hold function holds the maximum value reached after the hold command was received. The value will be refreshed if it increases again.
- **Averaging hold**
The averaging hold function averages weighing data over a certain period of time and then holds the result. It is useful for measuring things that are difficult to weigh such as an animal that won't settle down, or for averaging out the weight of an object in an unstable state. In addition, it can reduce the effects of breezes which the digital filter cannot eliminate.
- **Functions Related to the Hold Function**
 - **Fnc07(Hold)** : The type of hold function can be selected.
 - To set operating conditions for the hold function, set the averaging time length, standby time, or start and stop conditions with **HLd01** to **HLd07**. (Will not affect normal holds)

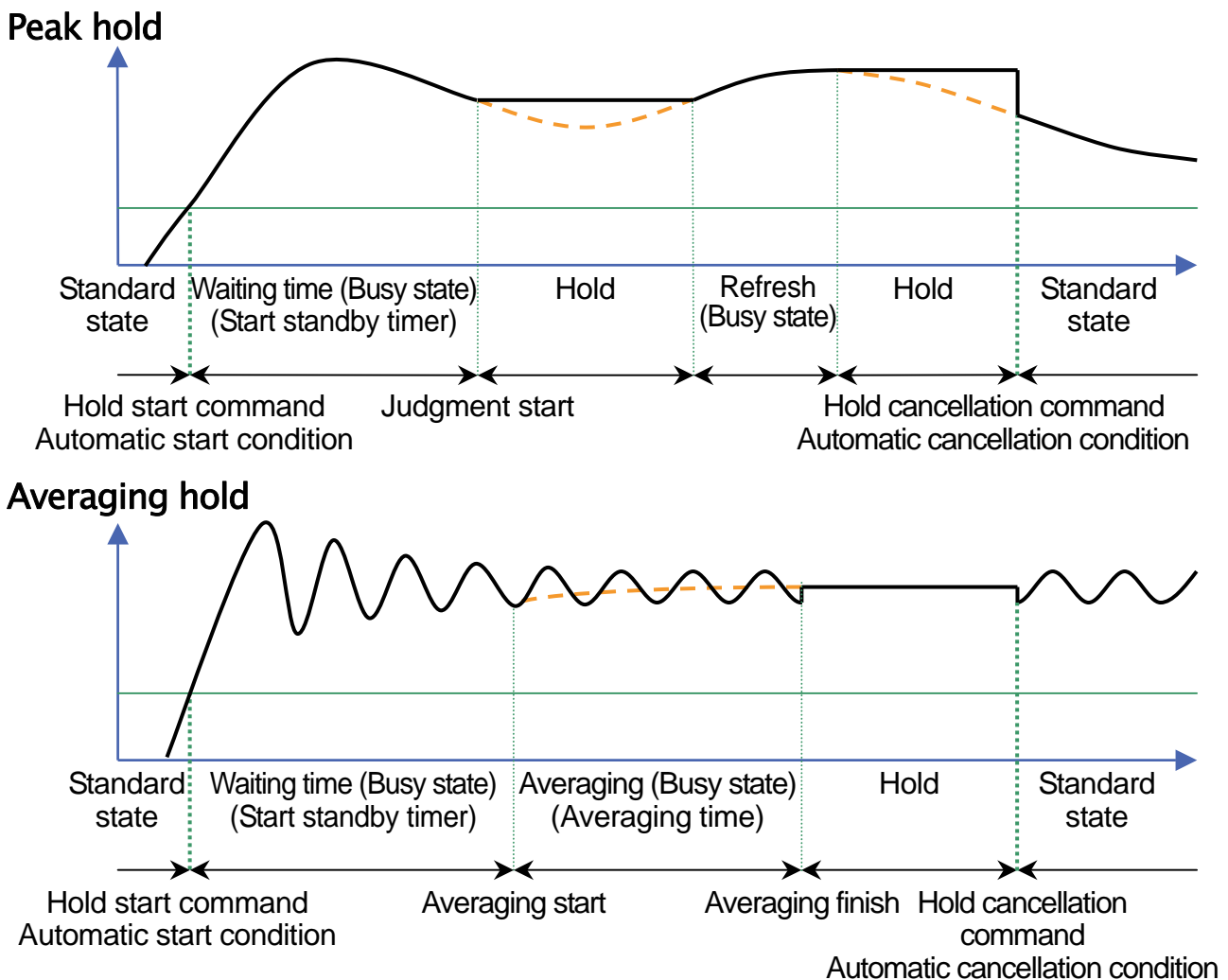

Illustration 7 Peak hold / Averaging hold

5.2. State Diagram And Operation Switches

5.2.1. State Diagram

- The module has several modes to perform various operations. Perform mode switching by the key operation shown below, only in the direction of the solid arrow. After setting a mode, the module resets automatically. Alternatively, the module resets when the power is disconnected.

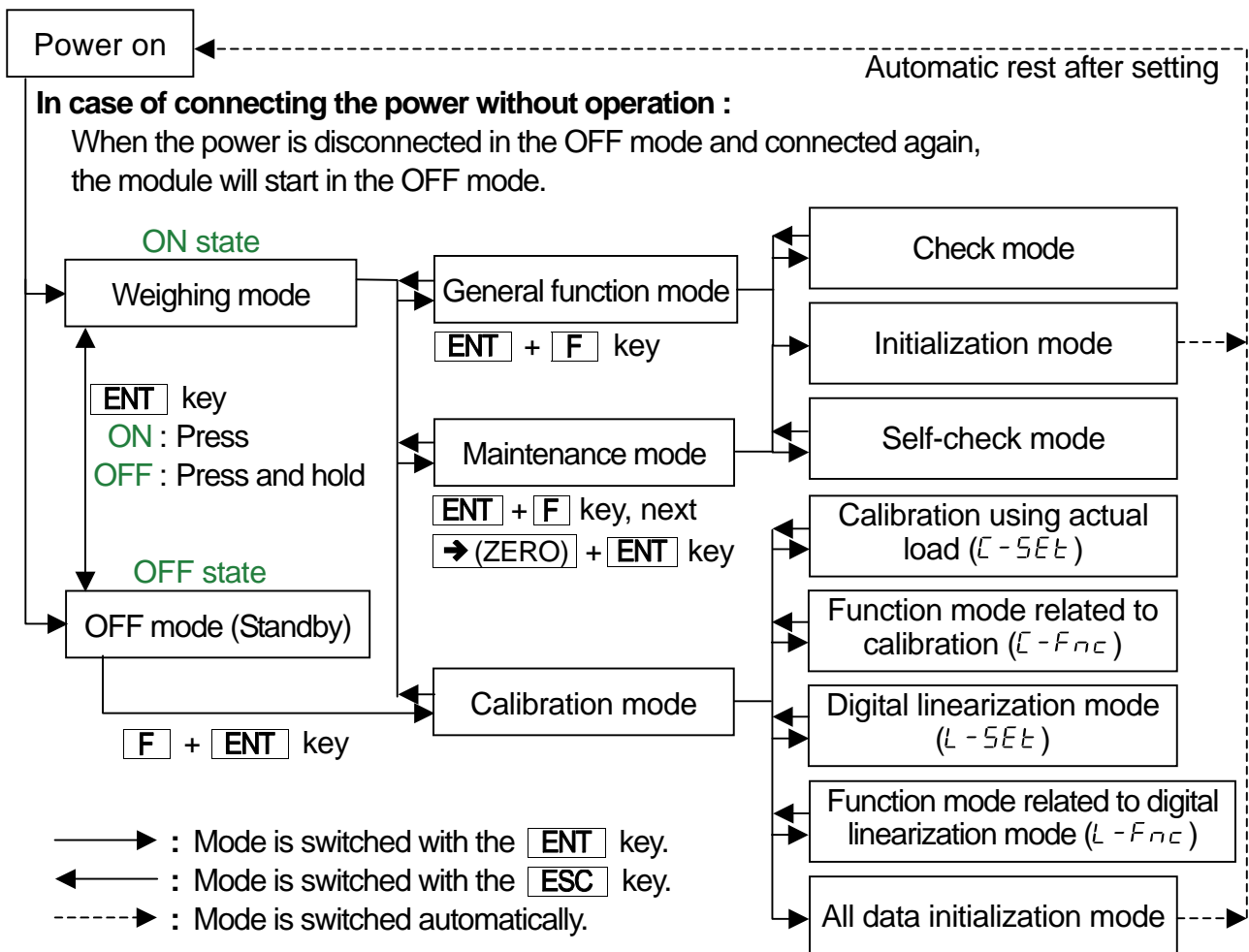

Illustration 8 State diagram

5.2.2. Operation Switches

Key	State	Function and Use
F	Weighing mode	The display switch between gross and net in factory setting. The function key to able to select an arbitrary function and use.
	Setting mode	The ESC key.
→	Weighing mode	The zero key to perform the zero operation.
	Setting mode	The key to change a selected item or move a flashed figure.
↑	Weighing mode	The tare key.
	Setting mode	The key to select parameter or increase number.
ENT	Weighing mode	The key to turn the module off when pressing and holding the key.
	OFF state (Standby)	The key to turn the module on.
	Setting mode	The key to store new settings.
ESC	Weighing mode	The function key (F key) to be selected the function and use.
	Setting mode	The return key or escape key.
ENT + F	Weighing mode	The keys to proceed to the function mode from weighing mode.
→ + ENT	Setting mode	The keys to proceed to the check mode from function mode.
F + ENT	OFF state (Standby)	The keys to proceed to the calibration mode from OFF state (Standby).

5.3. The Calibration

5.3.1. Outline of the Calibration

In the calibration mode, operations relating the load cell output voltage to the weighing value can be performed as well as operations directly related to weighing can be performed.

The calibration using actual load	<p>The calibration is performed using a calibration weight.</p> <ul style="list-style-type: none"> ■ Zero calibration : Press ENT key when no load is applied. ■ Span calibration : Enter the calibration weight value and place the calibration weight. <p>When the module enters the calibration mode using an actual load, the tare value and the zero value will be automatically cleared.</p>
Digital span	<p>The calibration is performed without an actual load by numerical input of the load cell output voltage (mV/V). Set these functions related to the calibration.</p> <ul style="list-style-type: none"> ■ Zero input voltage : Numerical input of the load cell output at zero. ■ Span input voltage : Numerical input of the load cell output of span. (Load cell output at full capacity – load cell output at zero) ■ The calibration weight value of span : Numerical input of the calibration weight value corresponding to the span input voltage. (These values relate the span input voltage and the calibration weight value.)
Gravity acceleration correction	<p>The span error is calculated and corrected when gravity acceleration between the calibration location and use location is different.</p>
Digital linearization	<p>The nonlinearity correction function to correct weighing errors that occur halfway between the zero point and maximum capacity. Up to 4 points can be input in addition to the zero point, and the intervals between each point will be calculated using curves.</p>
Function related to the calibration	<p>The function stores basic parameters of the module such as the minimum division and maximum capacity and other data directly related to weighing is performed. Digital span calibration and gravity acceleration correction setting are also performed here.</p>
All data initialization	<p>All the data such as zero value, tare value, calibration data and function data are initialized.</p>

- All the parameters in the calibration mode are stored in the FRAM.
- Actual load calibration and digital span can be mixed.
Example: For the zero calibration, an actual load is used. For the span calibration, the digital span is used.

5.3.2. The Calibration using Actual Load (C - S E t)

The calibration using actual load (C - S E t) is performed using a calibration weight. When performing the calibration for the first time, preset **C-F01** (Unit), **C-F02** (Decimal point position), **C-F03** (Minimum division) and **C-F04** (Maximum capacity) related to the calibration.

Note To avoid drift caused by changes in temperature, warm up the indicator for ten minutes or more before performing the calibration with an actual load.

Step 1 In the OFF mode (Standby), Press the **F** + **ENT** key to enter to the calibration mode and display **CAL**.

Step 2 Press the **ENT** key to start the calibration and display **C - S E t**. To return to the weighing mode, press the **ESC** key.

Zero Calibration

Step 3 Press the **ENT** key to display **CAL 0**.
If zero calibration is not to be performed, press the **↑** key and proceed to **Step 5**. To check the current weighing value, press the **→** key. When pressing the **↑** key again, **CAL 0** is display.

Step 4 Placed nothing on the pan and wait for the stabilization (**S** LED). Press the **ENT** key. **-----** is displayed for approximately two seconds. If span calibration is not performed, press the **ESC** key twice to return to the weighing mode.

Span Calibration

Step 5 Press the **ENT** key when **C - S P n** is displayed. The calibration weight value (the current maximum capacity) is displayed and the least digit of the value blinks. Correct the value using the **→** and **↑** key so as to be the value of the calibration weight used. If span calibration is not performed, press the **ESC** key three times to return to the weighing mode.

Step 6 Place the calibration weight on the pan. Wait for the stabilization (**S** LED). Press the **ENT** key. **-----** is displayed for approximately two seconds.

Step 7 **C - E n d** is displayed.

Step 8 Press the **ESC** key. **C - S E t** is displayed, and the calibration data is stored in the FRAM memory.

Step 9 The current state is the same as that of **Step 2**. To return to the weighing mode, press the **ESC** key.

- If **C E r X** is displayed, an error has occurred. Refer to “5.3.8. Error Codes for the Calibration” to take corrective action. X : number.
- The blinking decimal point means that the current value is not the weight value.

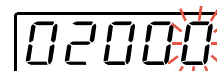
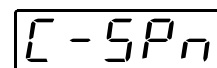
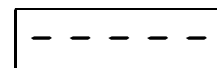
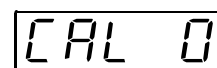
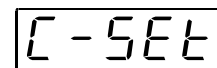
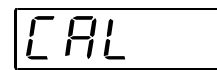

Example

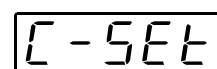
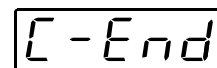
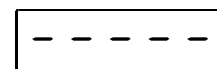

5.3.3. Gravity Acceleration Correction

- When the scale (weighing indicator) has been calibrated in the same place as it is being used, gravity acceleration correction is not required.
- A span error will appear if gravity accelerations are different between the calibration place and the use place. The gravity acceleration correction calculates and corrects this span error by these gravity acceleration correction values for both points (the calibration place and use place).

Note When the span is calibrated using actual load, the gravity acceleration correction settings are cleared, and the two gravity acceleration settings return to their default values.

- **Functions Related to the Gravity Acceleration Correction**
 - **C-F26** (Gravity acceleration of the calibration place):

The gravity acceleration where the module has been calibrated.
 - **C-F27** (Gravity acceleration of use place):

The gravity acceleration where the module is being used.

Gravity Acceleration Table

Amsterdam	9.813 m/s ²	Manila	9.784 m/s ²
Athens	9.800 m/s ²	Melbourne	9.800 m/s ²
Auckland NZ	9.799 m/s ²	Mexico City	9.779 m/s ²
Bangkok	9.783 m/s ²	Milan	9.806 m/s ²
Birmingham	9.813 m/s ²	New York	9.802 m/s ²
Brussels	9.811 m/s ²	Oslo	9.819 m/s ²
Buenos Aires	9.797 m/s ²	Ottawa	9.806 m/s ²
Calcutta	9.788 m/s ²	Paris	9.809 m/s ²
Chicago	9.803 m/s ²	Rio de Janeiro	9.788 m/s ²
Copenhagen	9.815 m/s ²	Rome	9.803 m/s ²
Cyprus	9.797 m/s ²	San Francisco	9.800 m/s ²
Djakarta	9.781 m/s ²	Singapore	9.781 m/s ²
Frankfurt	9.810 m/s ²	Stockholm	9.818 m/s ²
Glasgow	9.816 m/s ²	Sydney	9.797 m/s ²
Havana	9.788 m/s ²	Tainan	9.788 m/s ²
Helsinki	9.819 m/s ²	Taipei	9.790 m/s ²
Kuwait	9.793 m/s ²	Tokyo	9.798 m/s ²
Lisbon	9.801 m/s ²	Vancouver, BC	9.809 m/s ²
London (Greenwich)	9.812 m/s ²	Washington DC	9.801 m/s ²
Los Angeles	9.796 m/s ²	Wellington NZ	9.803 m/s ²
Madrid	9.800 m/s ²	Zurich	9.807 m/s ²

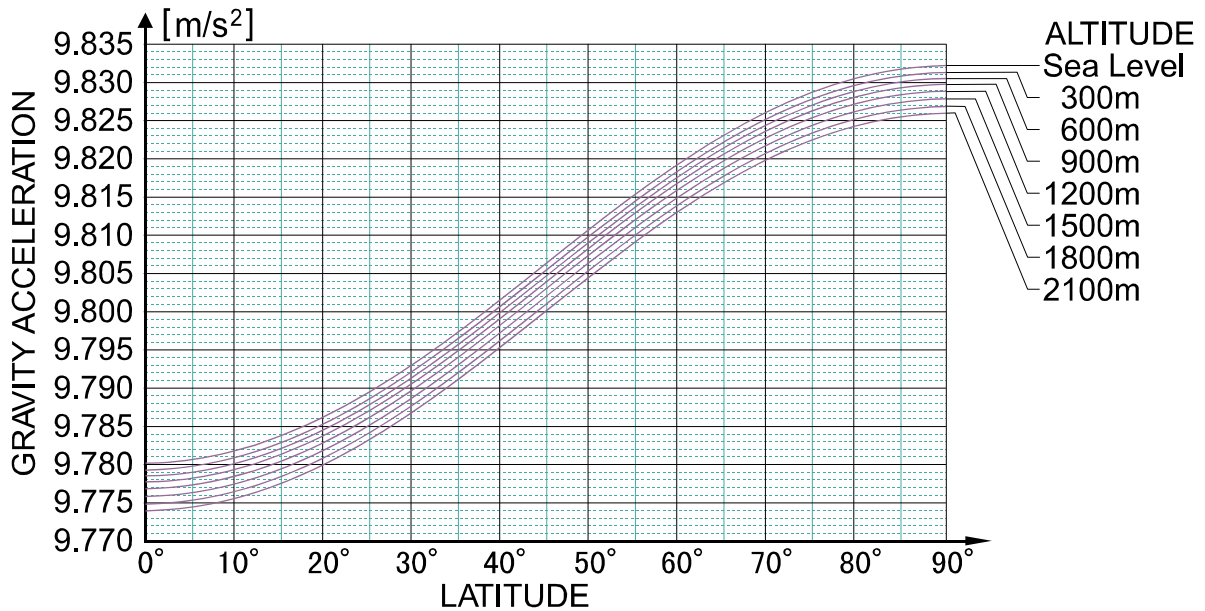

Illustration 9 Gravity acceleration graph

5.3.4. The Linearization Function

Outline

Even if zero and span calibration have been performed, weighing errors may occur between the zero point and maximum capacity. The digital linearization ($L - 5ET$) is a corrective function designed to non-linearly correct weighing errors.

- It is possible to input up to four points in addition to the zero point.
- The zero point and each input point will be corrected to put them in a straight line.
- Areas between input points that could not be corrected completely with straight line correction or with secondary correction will be corrected using a curved line derived from high-order equations.
- When the actual load input for digital linearization is performed, the calibrated data will be refreshed using zero point and final input point data. It is not necessary to calibrate again.

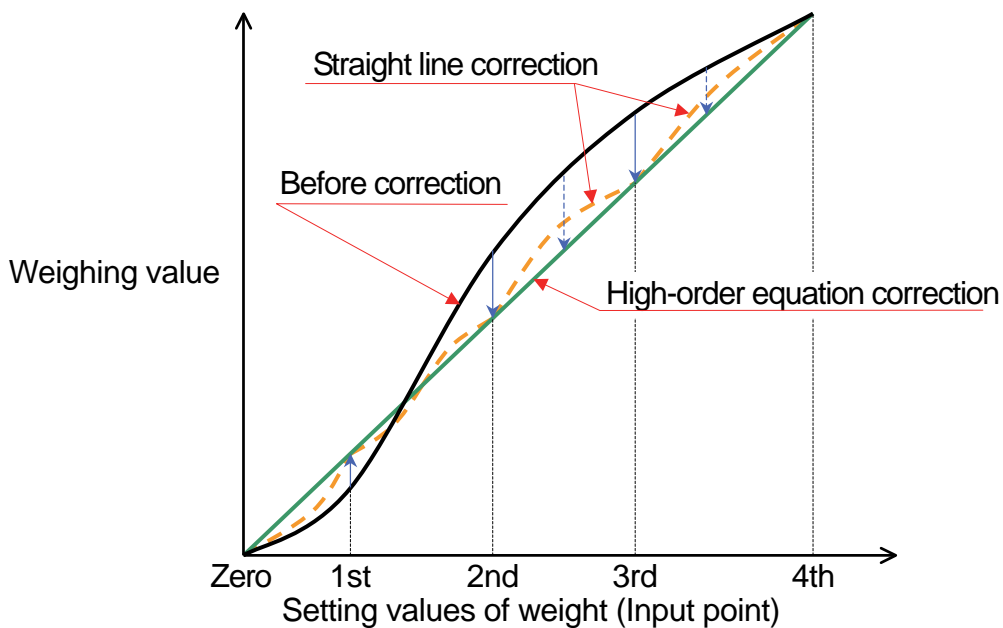

Illustration 10 Digital linearization

5.3.5. The Actual Load Linearization Function (L-SET)

Set the digital linearization by loading/unloading masses.

- Warm up the module for at least ten minutes to avoid the effects of temperature drift.
- The input order should proceed from the smallest mass to the largest mass.

Step 1 Press the **[F]** + **[ENT]** key to enter to the calibration mode and display **[CAL]**. Press the **[ENT]** key to start the calibration and display **[L-SET]**. Select **[L-SET]** using the **[↑]** key and press the **[ENT]** key.

CAL

L-SET

L-SET

Step 2 **[Lnr 0]** is displayed.

If monitoring the current weighing value, press the **[→]** key. When pressing the **[→]** key again, **[Lnr 0]** is display.

Lnr 0

Step 3 Placed nothing on the pan and wait for the stabilization (**S** LED). Press the **[ENT]** key. **[-----]** is displayed for approximately two seconds.

Step 4 **[Lnr 1]** is displayed.

If you want to check the current weighing value, press the **[→]** key. When pressing the **[→]** key again, **[Lnr 1]** is displayed. Press the **[ENT]** key. The weight value (the current maximum capacity) is displayed and the least digit of the value blinks. Correct the value using the **[→]** and **[↑]** key so as to be the weight value used.

Lnr 1

02000

00100

Sample

Step 5 Place the weight on the pan. Wait for the stabilization (**S** LED). Press the **[ENT]** key. **[-----]** is displayed for approximately two seconds.

Step 6 **[Lnr 2]** is displayed. Repeat step 4 and step 5. The procedure proceeds in order of **[Lnr 3]** → **[Lnr 4]** → **[L-End]**.

Lnr 2

L-End

Step 7 Proceed to step 8 to finish the input operation. If you re-input the digital linearization, select the input point using the **[↑]** key. All data following the new input point will be cleared.

Step 8 Press the **[ESC]** key. **[L-SET]** is displayed and the inputted data will be stored in the FRAM. At the same time, the calibrated data is also refreshed. Press again the **[ESC]** key to return to weighing mode.

L-SET

- When **[L Er x]** is displayed, an error will occur. **x** : error number. Refer to "5.3.8. Error Codes for the Calibration" for details.
- The blinking decimal point means that the current value is not the weight value.

5.3.6. The Function Related to the Calibration ([C-Fnc])

Step 1 Press the [F] + [ENT] key to enter to the calibration mode and display [CAL] .
 Press the [ENT] key to start the calibration and display [C-5Et] .
 Press the [ESC] key to return to weighing mode.

Step 2 Select [C-Fnc] using the [↑] key and press the [ENT] key.

Step 3 Select a desired function item (a function group name with function number) using the [↑] key and press the [ENT] key.
 The current data is displayed.

Step 4 When changing data, two methods of parameter selection and digital input depending on the function are available.

Type	Description of method to change data
Parameter selection	Only the available parameter is displayed and blinks. Select a number using the [↑] key.
Digital input	All the digits are displayed. A digit to be changed blinks. Select a digit using the [→] key and change the value using the [↑] key.

After changing data, press the [ENT] key. The next function number is displayed.
 When the value is not to be changed, press the [ESC] key to return to the function number display.

Step 5 Press the [ESC] key to store new data in FRAM and [C-Fnc] is displayed.
 Press again the [ESC] key to return to the weighing mode.

- The blinking decimal point means that the current value is not the weight value.
- If digital input data is out of range, [Errdt] is displayed, and the data is canceled.
- The function code on the next page is used for commands of the CC-Link and USB.

Item Name	Function code	Description, Range and Default value
C-F01 Unit	1001	0 : No used 1 : g 2 : kg 3 : t 4 : N 5 : kN
C-F02 Decimal point position	1002	Decimal point position of the weighting value 0 : 0 1 : 0.0 2 : 0.00 3 : 0.000 4 : 0.0000
C-F03 Minimum division	1003	Minimum division (d) of the weighting value 1 : 1 2 : 2 3 : 5 4 : 10 5 : 20 6 : 50
C-F04 Maximum capacity	1004	Maximum capacity of the module. Weighing is possible up to the value of this setting plus 8 digits. If the value exceeds this, overflow will occur and will not be displayed. #1 1 to 70000 to 99999
C-F05 Zero range	1005	The range to enable zero operation by the → (ZERO) key expressed as a percentage of the maximum capacity with the calibration zero point as the center. For example, if 2 is set, the value in the range of ±2% of the maximum capacity with the center at the calibration zero point will be to zero. When a power-ON zero is performed, the initial zero point will be the center. 0 to 2 to 100
C-F06 Zero tracking time	1006	Performs zero tracking using this setting in combination with the setting of C-F07 . When C-F06 stores 0.0, zero tracking will not be performed. Scale : 0.1 seconds. 0.0 to 5.0
C-F07 Zero tracking band	1007	Performs zero tracking using this setting in combination with the setting of C-F06 . When C-F07 stores 0.0, zero tracking will not be performed. Scale : 0.1 d (minimum division). 0.0 to 9.9

When **C-F06** = 1.0, **C-F07** = 4.5

Zero tracking follows the weight value drifting around the zero point and adjusts to display as zero.

d = minimum division = 1 digit

When **C-F06** = 2.0, **C-F07** = 0.5

Zero tracking functions when the weight value is drifting within the range shown in the graph.

#1: The decimal point position depends on **C-F02** (Decimal point position).

□ The function code on the next page is used for commands of the CC-Link and USB.

Item Name	Function code	Description, Range and <input type="text" value="Default value"/>
C-F08 Stability detection time	1008	Performs stability detection using this setting in combination with the setting of C-F09 . When C-F08 stores 0.0, stability detection will not be performed. (Stable all the time) Scale : 0.1 seconds. 0.0 to <input type="text" value="1.0"/> to 9.9
C-F09 Stability detection width	1009	Performs stability detection using this setting in combination with the setting of C-F08 . When C-F09 stores 0, stability detection will not be performed. (Stable all the time) Scale : 0.1 d (minimum division). 0 to <input type="text" value="2"/> to 9
<p>Stability detection outputs the STABLE signal when changes in the weight value are within a certain range during a certain time.</p>		
C-F10 Tare and zero at unstable weight value	1010	Tare and zero operation when unstable 0 : Disables both functions. <input type="text" value="1"/> : Enables both functions.
C-F11 Tare when the gross weight is negative	1011	Tare when the gross weight is negative. 0 : Disables tare. <input type="text" value="1"/> : Enables tare.
C-F12 Output when out of range and unstable	1012	Standard serial output when the weight value overflows or is unstable. 0 : Disables output. <input type="text" value="1"/> : Enables output.
C-F13 Exceeding negative gross weight	1013	To judge when the negative gross weight is exceeded. <input type="text" value="1"/> : Gross weight < -99999 2 : Gross weight < Negative maximum capacity 3 : Gross weight < -19 d
C-F14 Exceeding negative net weight	1014	To judge when the negative net weight is exceeded. <input type="text" value="1"/> : Net weight < -99999 2 : Net weight < Negative maximum capacity
C-F15 Clear the zero value	1015	Select whether or not to clear the zero value. 0 : Disables. <input type="text" value="1"/> : Enables.
C-F16 Zero setting when power is turned on	1016	Select whether or not to perform zero setting when power is turned on. <input type="text" value="0"/> : Not used. 1 : Use.

Item Name	Function code	Description, Range and Default value
C-F17 Input voltage at zero	1017	Input voltage from a load cell at zero. Scale : mV/V. This value is determined in zero calibration during the calibration with an actual load. Scale : 0.0001 mV/V. -7.0000 to <input type="text" value="0.0000"/> to 7.0000
C-F18 Span input voltage	1018	Input voltage from a load cell at span. This value and the value of C-F19 are determined in span calibration during the calibration with an actual load. Scale : 0.0001 mV/V. 0.0100 to <input type="text" value="3.2000"/> to 9.9999
C-F19 Weight against span Input voltage	1019	The calibration weight value corresponding to the input voltage at span of C-F18 . When performing digital span, C-F17 , C-F18 and C-F19 are required for the calibration. #1 1 to <input type="text" value="32000"/> to 99999
<p>NOTE:</p> <p>*1 Record the setting values of C-F17, C-F18 and C-F19 in the "Function list" at the end of the manual to prepare against a malfunction.</p> <p>*2 By changing the parameters of C-F17, C-F18 and C-F19, "Zero calibration" and "Span calibration" can be adjusted optionally. (Digital span accuracy approximately 1/5000. The accuracy varies depending on the load cell output accuracy and the conditions of the calibration.)</p> <p>Caution Excluding emergencies, perform the calibration with an actual load.</p>		
C-F26 Gravity acceleration of the calibration place	1026	Gravity acceleration of the place where the scale is calibrated. Scale : 0.0001 m/s ² . 9.7500 to <input type="text" value="9.8000"/> to 9.8500
C-F27 Gravity acceleration of use place	1027	Gravity acceleration of the place where the scale is being used. Scale : 0.0001 m/s ² . 9.7500 to <input type="text" value="9.8000"/> to 9.8500
C-F28 Suppression of the hold function	1028	<input type="text" value="0"/> : Permission 1: Prohibition

#1 : The decimal point position depends on **C-F02** (Decimal point position).

5.3.7. The Function Related to the Linearization Function (L - F n c)

- Confirm and change linearity settings.
To use this function, select L - F n c in the same way as the function related to the calibration are selected.

Item Name	Function code	Description, Range and Default value
L-F01 Number of input points	1101	Number of points where linear input was done. The linear-zero input is included as one point. Digital linearization is not performed when the set value is between 0 and 2. 0 to 5
L-F02 Linear-zero	1102	Voltage for linear-zero input. Scale : 0.0001 mV/V. -7.0000 to 0.0000 to 7.0000
L-F03 Setting value for linear 1	1103	The setting value of weight for linear 1 input. #1 0 to 99999
L-F04 Span at linear 1	1104	The span voltage between linear-zero and linear 1 input. Scale : 0.0001 mV/V. 0.0000 to 9.9999
L-F05 Setting value for linear 2	1105	The setting value of weight for linear 2 input. #1 0 to 99999
L-F06 Span at linear 2	1106	The span voltage between linear-zero and linear 2 input. Scale : 0.0001 mV/V. 0.0000 to 9.9999
L-F07 Setting value for linear 3	1107	The setting value of weight for linear 3 input. #1 0 to 99999
L-F08 Span at linear 3	1108	The span voltage between linear-zero and linear 3 input. Scale : 0.0001 mV/V. 0.0000 to 9.9999
L-F09 Setting value for linear 4	1109	The setting value of weight for linear 4 input. #1 0 to 99999
L-F10 Span at linear 4	1110	The span voltage between linear-zero and linear 4 input. Scale : 0.0001 mV/V. 0.0000 to 9.9999

#1 : The decimal point position depends on **C-F02** (Decimal point position).

5.3.8. Error Codes for the Calibration (C ErB)

When an error occurs during the calibration, the error number is displayed. If calibration is finished without removing the error, the setting values will be restored to the state before calibration.

Calibration errors and remedies

Error No.	Description of cause	Treatment
C Er1	The display resolution (maximum capacity / minimum division) exceeds the specified value.	Make the minimum division greater or make the maximum capacity smaller. The specified value depends on specifications of the weighing system.
C Er2	Voltage at zero calibration exceeds in the positive direction.	Check the load cell rating and connection. When nothing is wrong with the rating and connection, adjust the load cell output as described in the next section. When the load cell or A/D converter may be the cause of error, confirm this by using the check mode.
C Er3	Voltage at zero calibration exceeds in the negative direction.	
C Er4	The value of the calibration weight exceeds the maximum capacity.	Use an appropriate the calibration weight and calibrate again.
C Er5	The value of the calibration weight is less than the minimum division.	
C Er6	The load cell sensitivity is not sufficient.	Use a load cell with higher sensitivity or make the minimum division greater.
C Er7	Voltage at span calibration is less than voltage at the zero point.	Check the load cell connection.
C Er8	The load cell output voltage is too high when the mass of maximum capacity is weighed.	Use a load cell with a greater rating or make the maximum capacity smaller.

5.3.9. Adjustment of the Load Cell Output

Add a resistor as shown below to adjust the load cell output.

Use a resistor with a high resistance value and a low temperature coefficient.

"C Er2"

When exceeding in the positive direction.

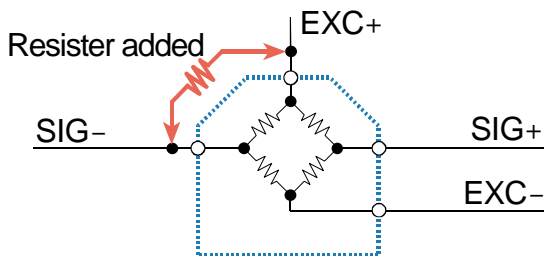

"C Er3"

When exceeding in the negative

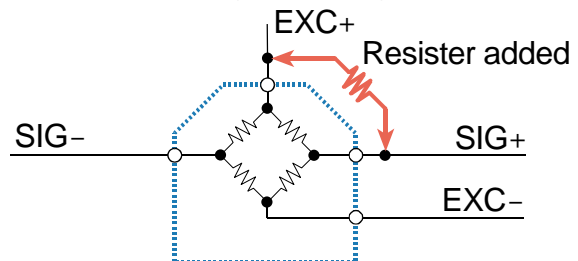

Illustration 11 Load cell output adjustment

- Because the zero point of the module has a wide adjustable range, correcting the output of a normal load cell is hardly ever required. Before an output correction is carried out, confirm load cells (deformation, wiring mistakes, contact with anything, or model selection etc.) and connections.

5.4. The List of General Functions

- In this section, the way of pre-setting and descriptions for the general functions are described. General functions are divided into groups according to function and are indicated by function item (a function group name with function number).

NOTE: General functions determine the module performance and all of the settings are stored in the FRAM.

5.4.1. The Procedure to Store New Parameters

Step 1 Press the **ENT** + **F** key to enter to the function mode and display **Fnc** .
Press the **ENT** key to start the function mode.
To return to the weighing mode, press the **ESC** key.

Step 2 Press the **↑** key to select the function group to be set.
Press the **ENT** key. The function group is as follows :

Display	Group name
<i>C-Fnc</i>	Calibration related
<i>L-Fnc</i>	Linearity adjustment related
<i>Fnc F</i>	Basics function related
<i>Hld F</i>	Hold function
<i>Sq F</i>	Weighing sequence related
<i>SP F</i>	Setpoint related
<i>io F</i>	Control I/O related
<i>CL F</i>	Standard serial output related
<i>CC F</i>	CC-Link related

Step 3 Press the **↑** key to select the function number to be set.
Press the **ENT** key. The current setting value is displayed.

Step 4 When changing parameter, two methods of parameter selection and digital input depending on the function are available.

Type	Description of method to change data
Parameter selection	Only the available parameter is displayed and blinks. Select a number using the ↑ key.
Digital input	All the digits are displayed. The digit to be changed blinks. Select the digit using the → key. Change the value using the ↑ key.

After changing data, press the **ENT** key. The next function number is displayed.
When the value is not to be changed, press the **ESC** key to return to the function number display.

Step 5 Press the **ESC** key to return to Step 2. Press the **ESC** key once to store new parameters in FRAM and to return to the weighing mode.

- The blinking decimal point means that the current value is not the weight value.
- If a data exceeding the available range is inputted, **Errdt** is displayed, and the data is canceled.
- The function code on the next page is used for commands of the CC-Link and USB.

5.4.2. The Adjustment of the Digital Filter

- Adjust the digital filter using **Fnc05** (digital filter).
The available settable range for the cutoff frequency is from 100 Hz to 0.7 Hz.
The cut off frequency is the frequency where vibrations declines to $1/\sqrt{2}$ times.
 - If the weighing value is unstable, set the cutoff frequency lower.
 - To make the response faster, set the cutoff frequency higher.

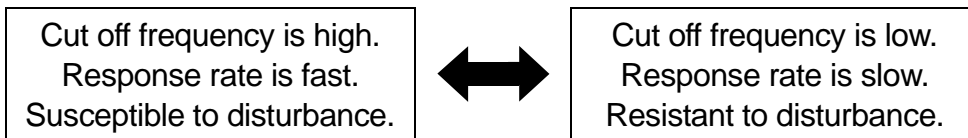

- It is possible to make adjustments while watching the effects of the digital filter with your own eyes. By pressing the key while setting **Fnc05** (digital filter), it is possible to check the weight displayed.

- key Increase stability.
- key Return to the value setting display.

5.4.3. The Use of the Second Digital Filter

- The AD-4430C is equipped with a second digital filter, which is capable of arithmetic processing simultaneously, in addition to regular weighing. The available settable range for the cutoff frequency is from 100 Hz to 0.07 Hz. Adjust the second digital filter using **Fnc06** (2nd digital filter). The weighing value of the second digital filter can be read from the remote register (4 stations occupied) of the CC-Link.
 - When controlling the large flow and medium flow gate on fast response, more stable weighing values are required.
 - Even when the displayed value is stable, amplitude increase and decrease according to peripheral noise can be monitored. It can be used to alarm of the weight checker when vibration noise increases.
 - Even when livestock is moving around, a weighing value with vibration reduced can be read.

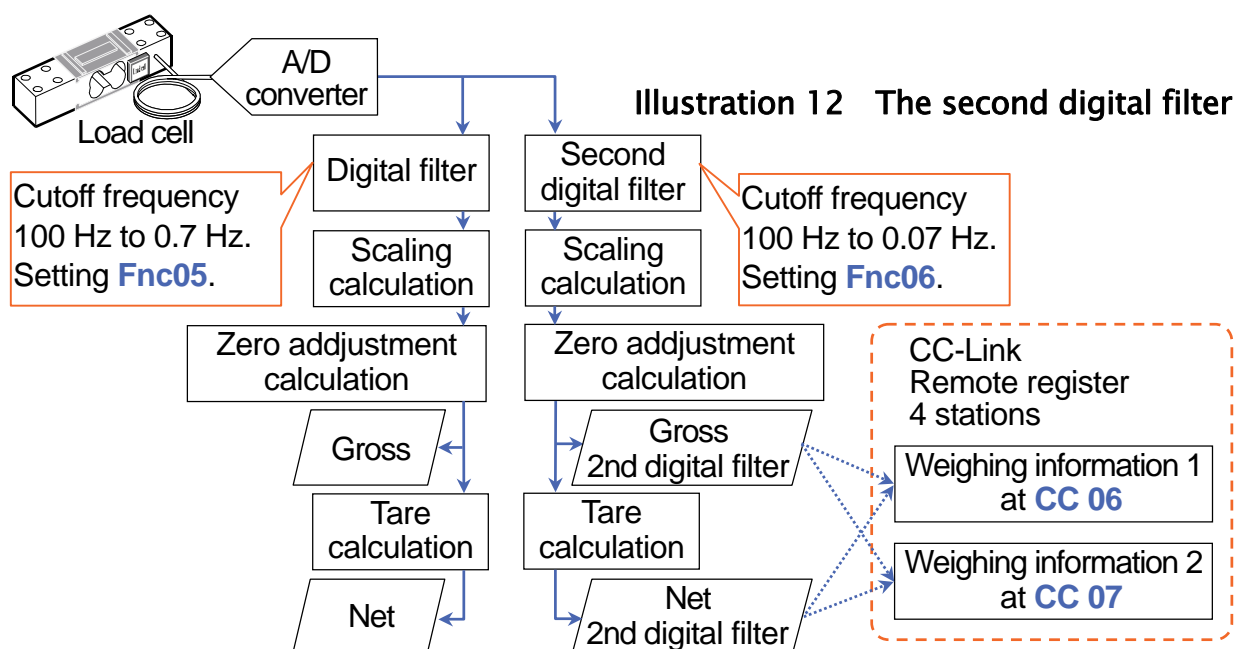

5.4.4. The Function Related to the Basics Function (Fnc F)

Item Name	Function code	Description, Range and Default value
Fnc01 Key switch disable	1201	Each digit of the setting corresponds to a key switch. Only available in the weighing mode. Key assignment to each binary digit. 0: Permission 1: Prohibition 4th 3rd 2nd 1st1 <input type="checkbox"/> ESC <input type="checkbox"/> → <input type="checkbox"/> ↑ <input type="checkbox"/> ENT <input type="text" value="0000"/> to 1111
Fnc02 <input type="checkbox"/> F key	1202	0: None 1: Manual print command 2: Hold 3: Alternative switch (Active <input type="checkbox"/> F key) 4: Momentary switch (Active <input type="checkbox"/> F key) <input type="checkbox"/> 5: Display exchange 6: Tare clear 7: Zero clear 8: Batch start / Pause / Re-start 9: Actual free fall input 10: One shot, Small flow 11: Flow rate monitor (Change rate) 12: mV/V monitor 13: Second digital filter (2nd D.F.)
Fnc03 Display rewrite rate	1203	<input type="checkbox"/> 1: 20 times/sec. 2: 10 times/sec. 3: 5 times/sec.
Fnc04 x display	1204	<input type="checkbox"/> 0 : None 1: Zero tracking in progress 2: Alarm (Zero range setting error, over) 3: Active <input type="checkbox"/> F key 4: Near-zero 5: HI output (Over the upper limit value) 6: OK output (Between upper and lower limit values) 7: LO output (Below the lower limit value) 8: Large flow 9: Medium flow 10: Small flow 11: Over 12: OK 13: Under 14: Full value 15: Weighing sequence, finished 16: Weighing sequence, in processing 17: Weighing sequence, error 18: Normal batch / Discharge, Identification (ON = Loss in weight) 19 to 24 : User input1 to 6 25 to 32 : User output 1 to 8
Fnc05 Digital filter	1205	Selects a cutoff frequency. 0 : None 6 :20.0 Hz 12 :2.8 Hz 1 :100.0 Hz 7 :14.0 Hz 13 :2.0 Hz 2 : 70.0 Hz 8 :10.0 Hz 14 :1.4 Hz 3 : 56.0 Hz 9 : 7.0 Hz <input type="checkbox"/> 15 :1.0 Hz 4 : 40.0 Hz 10 : 5.6 Hz 16 :0.7 Hz 5 : 28.0 Hz 11 : 4.0 Hz
Fnc06 Second Digital Filter (2nd D.F.)	1206	Selects a cutoff frequency. 0 : None 6 :20.0 Hz 12 :2.8 Hz 18 : 0.40 Hz 1 :100.0 Hz 7 :14.0 Hz 13 :2.0 Hz 19 :0.28 Hz 2 : 70.0 Hz 8 :10.0 Hz 14 :1.4 Hz 20 :0.20 Hz 3 : 56.0 Hz 9 : 7.0 Hz <input type="checkbox"/> 15 :1.0 Hz 21 :0.14 Hz 4 : 40.0 Hz 10 : 5.6 Hz 16 :0.7 Hz 22 :0.10 Hz 5 : 28.0 Hz 11 : 4.0 Hz 17 :0.56Hz 23 :0.07 Hz
Fnc07 Hold	1207	<input type="checkbox"/> 1: Normal hold 2 : Peak hold 3 : Averaging hold
Fnc08 Set near-zero	1208	The reference value for near-zero. Decimal point position depends on C-F02 (Decimal point position). -99999 to <input type="text" value="10"/> to 99999

Item Name	Function code	Description, Range and Default value
Fnc09 Comparison mass at near-zero	1209	Item to be compared with near-zero. 1: Gross weight 2: Net weight
Fnc10 Upper limit value	1210	Reference value for the upper limit. #1 -99999 to 10 to 99999
Fnc11 Lower limit value	1211	Reference value for the lower limit. #1 -99999 to -10 to 99999
Fnc12 Comparison mass of upper and lower limit	1212	Item to be compared with the upper and lower limit. 1: Gross weight 2: Net weight
Fnc13 Full value	1213	Reference value for the full value on gross weight. #1 -99999 to 99999

5.4.5. The Function Related to the Hold Function (H L d F)

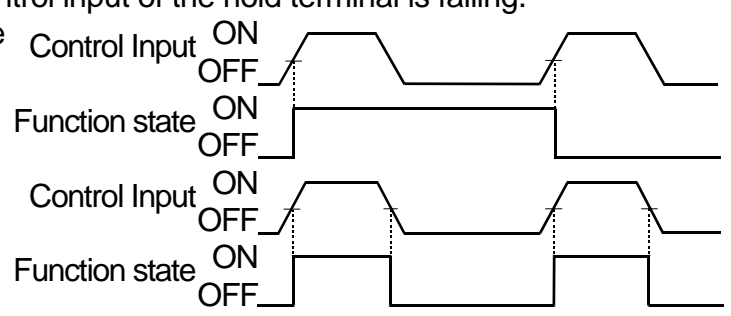
Item Name	Function code	Description, Range and Default value
HLd01 Averaging time	1301	Time to perform the averaging. 0.00 is not averaged. Scale : 0.01 seconds. 0.00 to 9.99
HLd02 Start wait time	1302	Waiting time to commence a holding or averaging. Scale : 0.01 seconds. 0.00 to 9.99
HLd03 Condition of automatic start	1303	The condition to commence a holding or averaging. 0: Not used 2 : Above the near-zero 1: Above the near-zero, and stable
HLd04 Release using control input	1304	Release when control input of the hold terminal is falling. 0: Do not release 1: Release 
HLd05 Release time	1305	Release after a set amount of time has passed. 0.00 is not averaged. Scale : 0.01 seconds. 0.00 to 9.99
HLd06 Release using fluctuation range	1306	Release when fluctuation from the holding value exceeds a set value. Scale : 0.01 seconds. #1 0 to 99999
HLd07 Release at near-zero	1307	Release when the weighing value is in the near-zero. 0 : Do not release. 1 : Release.

- This hold function only works when **Fnc07** (Hold) stores 2 (peak hold) or 3 (averaging hold). This hold function has no function when **Fnc07** (hold) stores 1 (normal hold).
 - **HLd01** (averaging time) works only when **Fnc07** (hold) stores 3 (averaging hold).
- #1 : The decimal point position depends on **C-F02** (Decimal point position).

5.4.6. The Function Related to the Weighing Sequence Program (59 F)

Item Name	Function code	Description, Range and Default value
Sq 01 Final value	1401	Final value or target weight. #1 -99999 to 0 to 99999
Sq 02 Free fall	1402	A value to close small flow gate. #1 -99999 to 0 to 99999
Sq 03 Preliminary	1403	A value to close medium flow gate. #1 -99999 to 0 to 99999
Sq 04 Optional preliminary	1404	A value to close large flow gate. #1 -99999 to 0 to 99999
Sq 05 Over	1405	A value for recognizing an over. #1 -99999 to 0 to 99999
Sq 06 Under	1406	A value for recognizing an under. #1 -99999 to 0 to 99999
Sq 07 Weighing mode	1407	0: No used 2: Discharge sequence 3: Specifying with control input 1: Normal batch sequence 4: Specifying with CC-Link
Sq 08 Automatic free fall correction	1408	0: No used 3: Real time free fall compensation (updated coefficient) 1: Moving average of last four times 2: Real time free fall compensation(fixed coefficient)
Sq 09 Automatic free fall band	1409	Weighing value is compensated automatically when net weight is within (final value ± this band). #1 0 to 99999
Sq 10 Active free fall coefficient	1410	Active free fall coefficient. Scale : 0.001 seconds. -99.999 to 0.000 to 99.999
Sq 11 Action of over and under	1411	1: Simple comparator 2: Synchronized to the end of weighing
Sq 12 Stability at judgment	1412	0: Unnecessary 1: Necessary
Sq 13 Tare at start	1413	0: Not used 1: Use It Sq 13 is set to 0, don't set C-F10 to 0 .
Sq 21 Batch monitoring timer	1421	A period of weighing sequence. If 0 is set, the timer is not used. Scale : 0.1 seconds. 0 to 600
Sq 22 Batch start wait timer	1422	Waiting time from the start of weighing sequence to the output. Scale : 0.1 seconds. 0.0 to 60.0
Sq 23 Timer of large flow comparison disable	1423	Timer for preventing gate from malfunctioning due to vibration when opening and closing the gate. Scale : 0.1 seconds. 0.0 to 60.0
Sq 24 Timer of medium flow comparison disable	1424	
Sq 25 Timer of small flow comparison disable	1425	
Sq 26 Judgment wait timer	1426	Waiting time between closing small flow gate and outputting comparison. Scale : 0.1 seconds. 0.0 to 0.1 to 60.0
Sq 27 Duration time of result	1427	Duration time of outputting weighing result. If 0.0 is set, the result is output until next weighing. Scale : 0.1 seconds. 0.0 to 60.0
Sq 28 One shot timer	1428	One shot timer for small flow gate. Scale : 0.01 seconds. 0.00 to 6.00

#1 : The decimal point position depends on C-F02 (Decimal point position).

5.4.7. The Function Related to the Setpoint (SP F)

Item Name	Function code	Description, Range and Default value	
SP01 Object of SP1	1501	Setting values concerning setpoints (SP) Caution : Do not select the same item to plural setpoints. 0 : Not used 1 : Final value 2 : Optional preliminary 3 : Preliminary 4 : Free fall 5 : Over 6 : Under 7 : Full 8 : Near-zero 9 : Free fall coefficient 10 : Upper limit 11 : Under limit	
SP02 Object of SP2	1502		0 to <input type="text" value="1"/> to 11
SP03 Object of SP3	1503		0 to <input type="text" value="2"/> to 11
SP04 Object of SP4	1504		0 to <input type="text" value="3"/> to 11
SP05 Object of SP5	1505		0 to <input type="text" value="4"/> to 11
SP06 Object of SP6	1506		0 to <input type="text" value="5"/> to 11
SP07 Object of SP7	1507		0 to <input type="text" value="6"/> to 11
SP08 Object of SP8	1508		0 to <input type="text" value="7"/> to 11
SP11 Parameter of SP1	1511	Setting parameters of setpoints (SP). The decimal point position depends on C-F02 (Decimal point position).	
SP12 Parameter of SP2	1512		-99999 to <input type="text" value="0"/> to 99999
SP13 Parameter of SP3	1513		-99999 to <input type="text" value="0"/> to 99999
SP14 Parameter of SP4	1514		-99999 to <input type="text" value="0"/> to 99999
SP15 Parameter of SP5	1515		-99999 to <input type="text" value="0"/> to 99999
SP16 Parameter of SP6	1516		-99999 to <input type="text" value="0"/> to 99999
SP17 Parameter of SP7	1517		-99999 to <input type="text" value="99999"/>
SP18 Parameter of SP8	1518		-99999 to <input type="text" value="10"/> to 99999

The setpoint (comparator data) is the function to compare data.

5.4.8. The Function Related to the Control I/O (IO F)

Item Name	Function code	Description, Range and Default value
io 01 Function of IN1	1601	0 : Not used 16 : Emergency stop (Level input) 1 to 6 : User output 1 to 6 17 : Error reset
io 02 Function of IN2	1602	7 : Zero 18 : Normal batch/ Discharge 8 : Tare exchange (level, ON = Loss in weight)
io 03 Function of IN3	1603	9 : Hold 19 : Actual free fall input
io 04 Function of IN4	1604	10 : Gross / Net exchange
io 05 Function of IN5	1605	11 : Diagnose 20 : One shot, Small flow 12 : Print command 21 : Full open (Level input)
io 06 Function of IN6	1606	12 : Batch start 22 : Zero clear 14 : Pause 23 : Tare clear 15 : Restart 24 : Active [F] key #1
io 11 Function of OUT1	1611	0 : Not used 23 : Large flow 1 to 8 : User output 1 to 8 24 : Medium flow
io 12 Function of OUT2	1612	9 : Stability 25 : Small flow
io 13 Function of OUT3	1613	10 : Over capacity 26 : Normal batch/ Discharge 11 : Net display (Identification, ON = Loss in weight)
io 14 Function of OUT4	1614	12 : During tare 27 : In weighing sequence
io 15 Function of OUT5	1615	13 : Hold 28 : End of weighing sequence
io 16 Function of OUT6	1616	14 : Hold busy 29 : Error of weighing sequence
io 17 Function of OUT7	1617	15 : HI output (Over the upper limit value)
io 18 Function of OUT8	1618	16 : OK output (Between upper and lower limit values)
io 21 OUT1 Logic	1621	17 : LO output (Below the lower limit value)
io 22 OUT2 Logic	1622	18 : Near-zero 30 : In weighing (ON)
io 23 OUT3 Logic	1623	19 : Full 31 : In weighing (1 Hz)
io 24 OUT4 Logic	1624	20 : Over 32 : In weighing (50 Hz)
io 25 OUT5 Logic	1625	21 : OK 33 : Alarm
io 26 OUT6 Logic	1626	22 : Under 34 : Active [F] key #2
io 27 OUT7 Logic	1627	
io 28 OUT8 Logic	1628	

- 1 : Inverting output
If data is "0" level, the output transistor conducts (ON).
- 2 : Non inverting output
If data is "1" level, the output transistor conducts (ON).

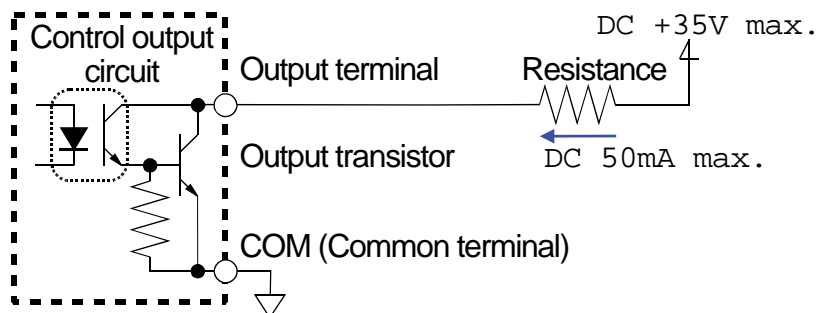

- #1** When **Fnc02** (**F** key) stores 3 (Alternative switch), the function is effective.
 When **Fnc02** (**F** key) stores 4 (Momentary switch), the function is ineffective.
- #2** When **Fnc04** (x display) stores 3 (Active **F** key), the function becomes the same as the display x.

5.4.9. The Function Related to the Standard Serial Output (*EL F*)

Item Name	Function code	Description, Range and Default value
CL 01 Serial data	1701	<input type="checkbox"/> 1 : Weighing display 3 : Net 5 : Gross / Net / Tare 2 : Gross 4 : Tare
CL 02 Communication mode	1702	<input type="checkbox"/> 1 : Stream 2 : Automatic print 3 : Manual print
CL 03 Baud rate	1703	1 : 600 bps <input type="checkbox"/> 2 : 2400 bps

5.4.10. The Function Related to the CC-Link (*EE F*)

Item Name	Function code	Description, Range and Default value
CC 01 Station number	1801	Station number for this module <input type="checkbox"/> 1 to 64
CC 02 Number of the remote register occupied	1802	0 : 1 station 1 : 2 stations <input type="checkbox"/> 2 : 4 stations
CC 03 Baud rate	1803	0 : 156 kbps 2 : 2.5 Mbps <input type="checkbox"/> 4 : 10 Mbps 1 : 625 kbps 3 : 5 Mbps
CC 04 Initial process	1804	0 : Not needed <input type="checkbox"/> 1 : Necessary
CC 05 Output data	1805	<input type="checkbox"/> 0 : Weighing display 1 : Net 2 : Gross
CC 06 Weighing information 1	1806	<input type="checkbox"/> 0 : Not used 6 : Flow rate (In small flow OFF) 1 : Sequence number 7 : Flow rate (Real time) 2 : Batch weighing error 8 : Load cell output. Scale : 1 nV/V 3 : Actual free fall 9 : Net (2nd digital filter)
CC 07 Weighing information 2	1807	4 : Free fall (Averaging) #1 10 : Gross (2nd digital filter) 5 : Free fall coefficient (Averaging) #1

#1 : Free fall and free fall coefficient are recalculated at the end of the weighing even if **Sq 08** (Automatic free fall correction) is set either parameter.

If **Sq 08** (Automatic free fall correction) is set to 2 (Real time free fall compensation(fixed coefficient)), **Sq 10** (Active free fall coefficient) is always used.

If **Sq 08** (Automatic free fall correction) is set to 3 (Real time free fall compensation (updated coefficient)), **Sq 10** (Active free fall coefficient) is always recalculated.

5.5. Weighing Sequence

5.5.1. Normal Batch Sequence

Large flow off	Net \geq Final value	- Optional preliminary
Medium flow off	Net \geq Final value	- Preliminary
Small flow off	Net \geq Final value	- Free fall
Over	Net $>$ Final value	+ Over
Under	Net $<$ Final value	- Under
Full	Gross \geq Full	
Near-zero	Gross \leq Near-zero	

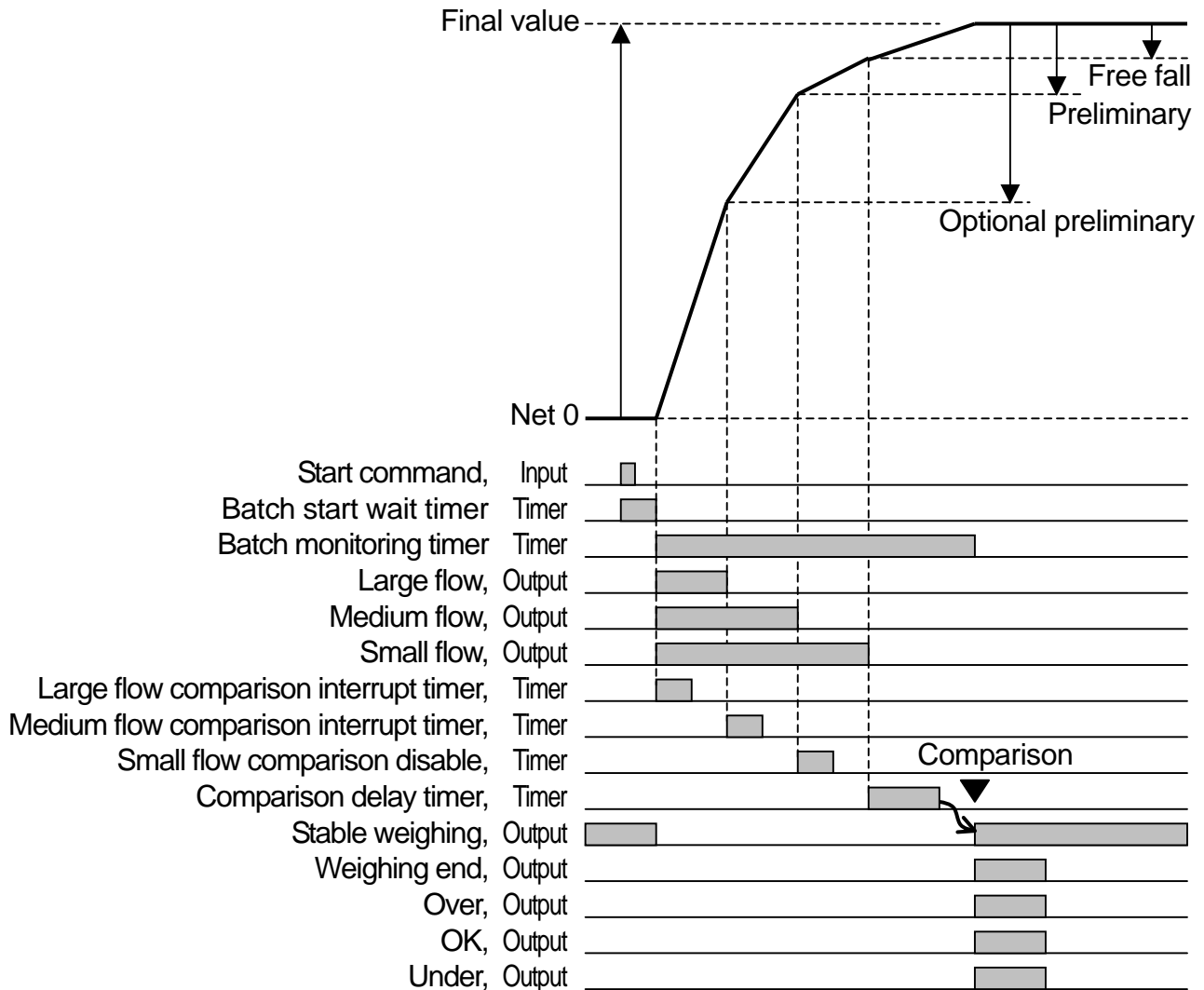

Illustration 13 Normal batch sequence

- The sequence can be restarted by a restart command input if it is stopped by a pause.
- An error output turns on when the sequence is stopped by an emergency stop input, full value and over, but except full and over during comparison prohibition. The sequence does not start when the full and over are guessed.
 - When final value is more than full value, the sequence does not start.
 - When gross + final value is more than full value, the sequence does not start.
- At the near-zero, comparison and output are performed only.

Steps of Normal Batch Sequence

Sequence No.	Item	Description of process
0	Sequence off	Waiting for a signal of the batch start input.
1	Tare	Tare and get a zero display.
2	Start condition check	Confirm the start condition.
3	Batch start wait timer	Full , medium and small flow are turned on after this timer.
4	Large flow comparison disable	Wait for the large flow comparison disable to elapse.
5	Large flow comparison	Turns off the large flow when net reaches to "final value - optional preliminary".
6	Medium flow comparison disable	Wait for the medium flow comparison disable to elapse.
7	Medium flow comparison	Turns off the medium flow when net reaches "final value - preliminary".
8	Small flow comparison disable	Wait for the small flow comparison disable to elapse.
9	Small flow comparison	Turns off the small flow when net reaches "final value - free fall".
10	Comparison delay timer	Wait for the judgment wait timer to elapse.
11	Stable weighing timer	Wait for the stable weighing value.
12	Weighing end output	The comparison result is output. Wait for the Weighing end output timer to elapse. The sequence is finished.

Operations

Operation	Description
Batch start	Starts the weighing sequence from first step.
Pause	Stops the weighing sequence and enters an error status.
Restart	Resumes the weighing sequence.
Emergency stop (Level input)	Stops the weighing sequence and enters an error status.
Error reset	Initializes the weighing sequence.
Normal batch / Discharge exchange (Level input)	Exchanges between normal batch (OFF) / loss in weight (ON).
Actual free fall input	It optimizes to latest parameters of Sq 02 (Free fall) and Sq 10 (Free fall coefficient) using latest weighing result. "Active free fall compensation (Updated coefficient)(3)" of Sq 08 (Automatic free fall correction) does not optimize. It is used when adjusting the weighing module and changing weighing materials.
One shot, Small flow	While Sq 28 (One shot timer) is active, the output signal of the small flow gate is active (ON). It accumulates the (ON) time concerning the signal output of the small flow gate. It is used to a compensation input for the shortage.
Full open (Level input)	While the signal of "Full open" is active, the signal of the large flow gate, medium flow gate and small flow gate are active (ON). It is used for discharging all things and cleaning of the hopper, etc. .

5.5.2. Loss in Weight Sequence

Large flow off	-Net \geq Final value	- Optional preliminary
Medium flow off	-Net \geq Final value	- Preliminary
Small flow off	-Net \geq Final value	- Free fall
Over	-Net $>$ Final value	+ Over
Under	-Net $<$ Final value	- Under
Full	Gross \geq Full	
Near-zero	Gross \leq Near-zero	

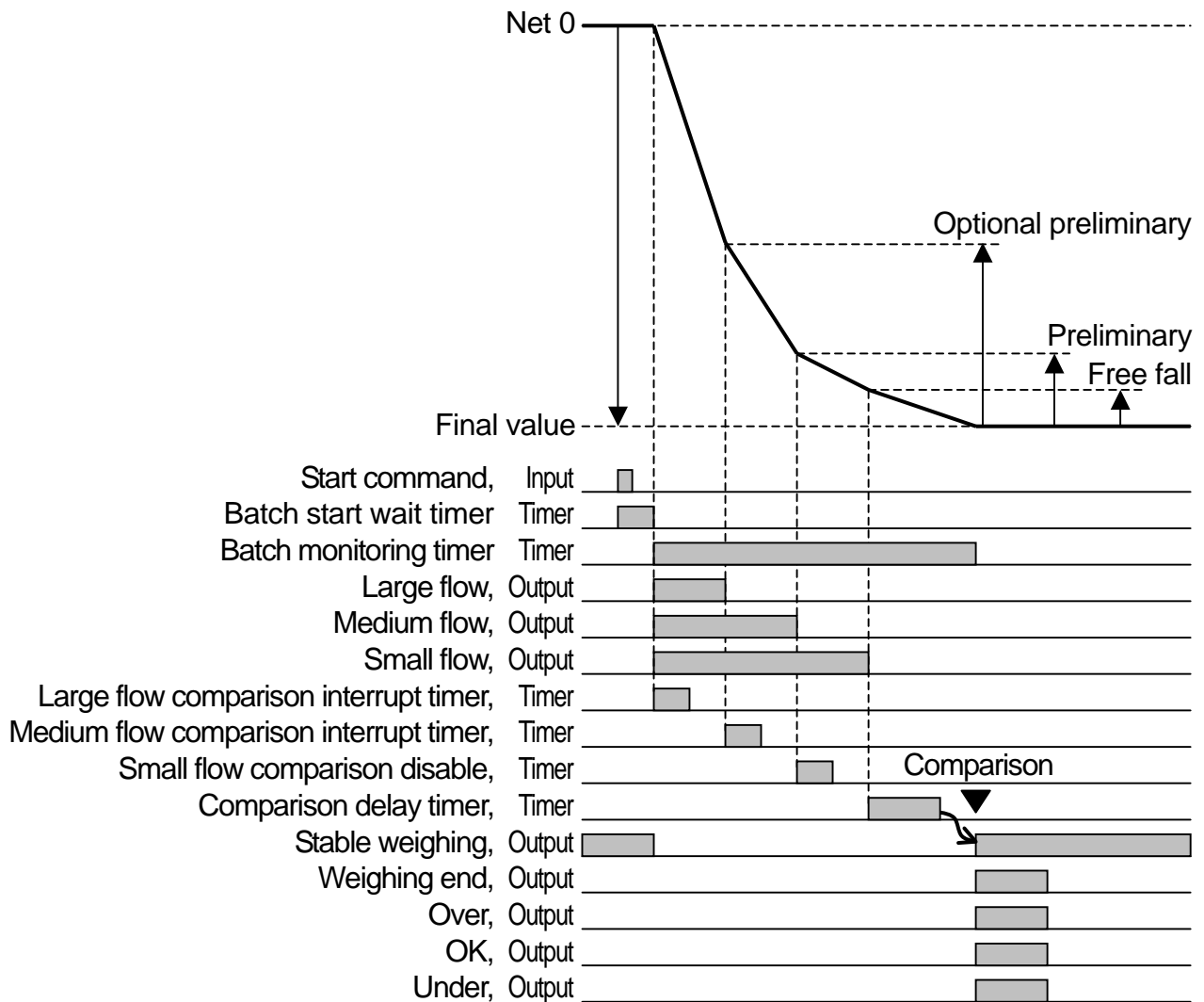

Illustration 14 Loss in weight sequence

- The sequence can be restarted by a restart command input if it is stopped by a pause.
- An error output turns on when the sequence is stopped by an emergency stop input. The sequence does not start when the remain in the hopper volume is not enough.
- The sequence does not start when a weighing value of the hopper is at the near-zero. At the near-zero, comparison and output are performed only.

Steps of Loss in Weight Sequence

Sequence No.	Item	Description of process
0	Sequence off	Waiting for a signal of the batch start input.
1	Tare	Tare and get a zero display.
2	Start condition check	Confirm the start condition.
3	Batch start wait timer	Full , medium and small flow are turned on after this timer.
4	Large flow comparison disable	Wait for the large flow comparison disable to elapse.
5	Large flow comparison	Turns off the large flow when negative net value reaches to "final value - optional preliminary".
6	Medium flow comparison disable	Wait for the medium flow comparison disable to elapse.
7	Medium flow comparison	Turns off the medium flow when negative net value reaches "final value - preliminary".
8	Small flow comparison disable	Wait for the small flow comparison disable to elapse.
9	Small flow comparison	Turns off the small flow when negative net value reaches "final value - free fall".
10	Comparison delay timer	Wait for the judgment wait timer to elapse.
11	Stable weighing timer	Wait for the stable weighing value.
12	Weighing end output	The comparison result is output. Wait for the Weighing end output timer to elapse. The sequence is finished.

Operations

Operation	Description
Batch start	Starts the weighing sequence from first step.
Pause	Stops the weighing sequence and enters an error status.
Restart	Resumes the weighing sequence.
Emergency stop (Level input)	Stops the weighing sequence and enters an error status.
Error reset	Initializes the weighing sequence.
Normal batch / Discharge exchange (Level input)	Exchanges between normal batch (OFF) / loss in weight (ON).
Actual free fall input	It optimizes to latest parameters of Sq 02 (Free fall) and Sq 10 (Free fall coefficient) using latest weighing result. "Active free fall compensation (Updated coefficient)(3)" of Sq 08 (Automatic free fall correction) does not optimize. It is used when adjusting the weighing module and changing weighing materials.
One shot, Small flow	While Sq 28 (One shot timer) is active, the output signal of the small flow gate is active (ON). It accumulates the (ON) time concerning the signal output of the small flow gate. It is used to a compensation input for the shortage.
Full open (Level input)	While the signal of "Full open" is active, the signal of the large flow gate, medium flow gate and small flow gate are active (ON). It is used for discharging all things and cleaning of the hopper, etc. .

5.5.3. Automatic Free Fall Correction

The Automatic free fall correction is the function to reduce weighing errors concerning a batch weighing. A weighing value may increase between closing the dribble gate and finishing weighing of a hopper scale and etc. This increased value is called "free fall". It is necessary to equalize a free fall parameter to real free fall value if minimizing weighing errors. As this method, there is the "averaging last four real free fall" that these weighing values are automatically updated. Formula of batch error and real free fall are as follows:

Batch error = Net value when the batch is finished – Preliminary

Real free fall = Net value when the batch is finished – Net value when the small flow gate is OFF

When the weighing value passes at "Preliminary – Final value", turn off the small flow gate.

When a batch error exceeds the effective range of the automatic free fall, the batch weighing is regarded as an error and removed from the last four weighing results.

5.5.4. Active Free Fall Compensation

The active free fall compensation is function that modifies the free fall compensation for corresponding to the velocity passing the gate (flow rate).

Example: When discharging a liquid (water, cement, tar) in the hopper, flow rate decreases as the remaining amount reduces. In this case, the weighing results always become short with the conventional free fall compensation. The same problem occurs with something like honey whose viscosity changes according to temperature.

Free fall coefficient = Actual free fall / Flow rate (when the small flow gate is OFF)

Free fall = Free fall coefficient x Flow rate

When the "Active free fall compensation (fixed coefficient) (2)" is set to the **Sq 08** (Automatic free fall correction), the free fall is calculated with the parameter of the **Sq 10** (Active free fall coefficient). When the "Active free fall compensation (updated coefficient) (3)" is set to the **Sq 08**, the free fall is calculated with the average of the last four weighing values. When a batch error exceeds an effective range of the automatic free fall, the batch weighing is regarded as an error and removed from the last 4 weighing results.

5.6. Setpoint (Comparator value)

These parameters of the **SP1** to **SP8** (setpoint) store items of fundamental setpoint for the weighing sequence. The **SP11** to **SP18** (parameter of the setpoint) store setpoint values of the **SP1** to **SP8** (setpoint). These function can be selected with **SP1** to **SP8** (setpoint). The remote registers of 4 stations are occupied in the initial settings for the CC-Link. Change it if needed. To keep the original settings, set "not used (0)".

Parameter & Item	Relation item
0: Not used	Not related
1: Final value	Sq 01
2: Optional preliminary	Sq 04
3: Preliminary	Sq 03
4: Free fall	Sq 02
5: Over	Sq 05

Parameter & Item	Relation item
6: Under	Sq 06
7: Full	Fnc13
8: Near-zero	Fnc08
9: Free fall coefficient	Sq 10
10: Upper limit	Fnc10
11: Under limit	Fnc11

6. Interface

6.1. Control I/O

- Using a control input from peripherals, data can be monitored and be output.
- Using a control output, a weighing status and weighing result can be output.
- Using user I/O (remote I/O), external switches and sensors can be monitored and controlled without setting a special tool. The sensor and the switch can be controlled together with the unit.
- The input and output circuit is isolated from the DC power supply terminals and load cell terminals.
- Supply DC +24 V between the power supply input terminal (I/O PWR +24V) and COM terminal.

Part of input

Input circuit type	DC input
Input tolerance	DC 35 V max.
Input open voltage	According to use
OFF current	0.1 mA max.
ON current	2.7 mA min.
Input threshold voltage	2 V

Part of output

Output circuit type	Open collector
Isolation	Photo coupler
Output voltage	DC 35 V max.
Output current	50 mA max.
Output saturation voltage	1.1 V max.

Control I/O

IN 6	20	10	IN 5
IN 4	19	9	IN 3
IN 2	18	8	IN 1
OUT8	17	7	OUT7
OUT6	16	6	OUT5
OUT4	15	5	OUT3
OUT2	14	4	OUT1
C.L.	13	3	C.L.
I/O PWR +24V	12	2	COM
	11	1	

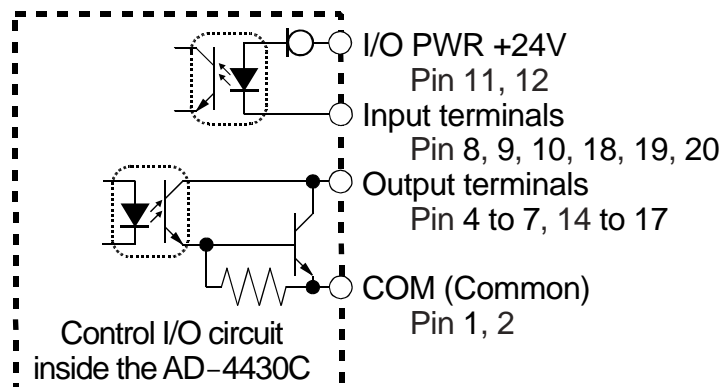

□ The function assigned to terminals

- The **io 01** (IN1 function) to **io 06** (IN6 function) :

Assign the function to these input terminals.

0 : Not used	16 : Emergency stop (Level input)
1 to 6 : User output 1 to 6	17 : Error reset
7 : Zero	18 : Normal batch/ Loss in weight change (level, ON = Loss in weight)
8 : Tare	19 : Actual free fall input
9 : Hold	20 : One shot, Small flow
10 : Gross / Net exchange	21 : Full open (Level input)
11 : Diagnose	22 : Zero clear
12 : Print command	23 : Tare clear
13 : Batch start	24 : Active F key
14 : Pause	
15 : Restart	

- The **io 11** (OUT1 function) to **io 18** (OUT8 function) :
Assign the function to these output terminals.

0 : Not used	22 : Under
1 to 8 : User output 1 to 8	23 : Large flow
9 : Stability	24 : Medium flow
10 : Over capacity	25 : Small flow
11 : Net display	26 : Normal batch/ Loss in weight (Identification, ON = Loss in weight)
12 : During tare	27 : In weighing sequence
13 : Hold	28 : End of weighing sequence
14 : Hold busy	29 : Error of weighing sequence
15 : HI output (Over the upper limit value)	30 : In weighing (ON)
16 : OK output (Between upper and lower limit values)	31 : In weighing (1 Hz)
17 : LO output (Below the lower limit value)	32 : In weighing (50 Hz)
18 : Near-zero	33 : Alarm
19 : Full	34 : Active [F] key #1
20 : Over	
21 : OK	

#1 When **Fnc02** is 3, the fuction is effective. When **Fnc02** is 3, the function is ineffective.

- The **io 21** (OUT1 logic) to **io 28** (OUT8 function) :
Assign the logic to these output terminals.

1 : Inverting output	If data is "0" level, the output transistor conducts (ON).
2 : Non inverting output	If data is "1" level, the output transistor conducts (ON).

6.2. Serial Output (Current Loop)

- The current loop (C.L.) circuit is isolated from all terminals.
- The standard serial output can connect to the A&D external display and printer.
- The current loop output needs to supply DC current from an external DC power source.
- The current loop terminals of the AD-4430C have non-polarity.
- The current loop terminals are pin 3 and 13 of the control I/O connector.

Transmission	0 - 20 mA, Current loop
Data length	7 bits
Start bit	1 bit
Parity bit	Even
Stop bit	1 bit
Baud rate	600 bps, 2400 bps
Code	ASCII

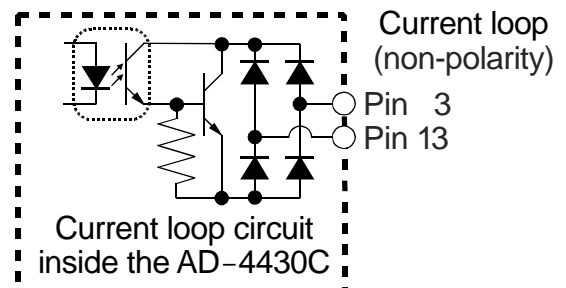

6.2.1. Data format of Serial Output

- The "A&D standard format" is used to the output format for communication with the A&D printer, and external display and consists of dual headers, data, unit and terminator.

A&D standard format

Header 1		Header 2		Data (Polarity, 8 digits including decimal point)								Unit		Terminator			
S	T	,	G	S	,	+	0	1	2	3	.	4	5	k	g	CR	LF

Item	ASCII code	Hexadecimal	Description
Header 1	ST	[53 54]	Stable
	US	[55 53]	Unstable
	OL	[4F 4C]	Overload
Header 2	GS	[47 53]	Gross
	NT	[4E 54]	Net
	TR	[54 52]	Tare
Punctuation	,	[2C]	Comma
Data (ASCII code)	0 to 9	[30 to 39]	Numerical number
	+	[2B]	Positive sign
	-	[2D]	Negative sign
	SP	[20]	Space
	.	[2E]	Dot
Unit (4 types)	SP SP	[20 20]	Not used
	SP g	[20 67]	g (gram)
	kg	[6B 67]	kg (kilogram)
	SP t	[20 74]	t (ton)

Examples of the A&D standard format

	Header 1		Header 2		Data (Polarity, 8 digits including decimal point)								Unit		Terminator				
Gross	S	T	,	G	S	,	+	0	0	1	2	3	4	5	k	g	CR	LF	Header 2 [GS]
Net	S	T	,	N	T	,	+	0	0	1	0	0	0	0	k	g	CR	LF	Header 2 [NT]
Tare	S	T	,	T	R	,	+	0	0	0	2	3	4	5	k	g	CR	LF	Header 2 [TR]
Including "."	S	T	,	G	S	,	+	0	1	2	3	.	4	5	k	g	CR	LF	Numerical part [.]
+Over	O	L	,	G	S	,	+	SP	SP	SP	SP	.	SP	SP	k	g	CR	LF	Header 1 [OL]
-Over	O	L	,	G	S	,	-	SP	SP	SP	SP	.	SP	SP	k	g	CR	LF	Header 1 [OL], Polarity [-]
Unstable	U	S	,	G	S	,	+	0	1	2	3	.	4	5	k	g	CR	LF	Header 1 [US]
Output data	O	L	,	G	S	,	+	SP	SP	SP	SP	.	SP	SP	k	g	CR	LF	Same as +Over

The position of decimal point is fixed even if data is out of range.

6.2.2. Transfer Mode of Serial Output

The type of the standard serial output is 3 types of "stream", "automatic print" and "manual print".

Stream	The data is output at each display rewrite. If the data cannot be output completely due to a slow baud rate, the data is output at the next rewrite. The output data uses a displayed data. Therefore, hidden data is not output.
Automatic printing	<p>□ There are two automatic printing mode.</p> <p>Mode 1 When a weighing value becomes at 5 counts or more and is stable, data output is performed once. It is necessary that data become less than 5 counts to output data again.</p> <p>Mode 2 Data is once output at the end of the weighing.</p> <p>When use mode 1, set as follows: Set Fnc07 (Hold) to "Normal hold (1)" and Set Sq 07 (Weighing mode) to "No used (0)".</p> <p>When use mode 2, set as follows: Set Sq 07 (Weighing mode) except to "No used (0)".</p>
Manual printing	When "manual printing" is selected, receiving a printing command from the CC-Link or pressing the assigned print key, data is output.

6.3. The CC-Link

The AD-4430C is the remote device station of the CC-Link interface version 1.10. When using the CC-Link, the AD4430C can be controlled on remote I/O and remote register, so the program may be simplified.

- Use the connector authorized by the CC-Link.

Station number	1 to 64
Number of the remote register occupied	1 station, 2 stations, 4 stations
Baud rate	156 kbps, 625 kbps, 2.5 Mbps, 5 Mbps, 10 Mbps

Status LED of the CC-Link

LED	Indication	Turning off	Blinking
RUN	Normal	Resetting, No signal	-
SD	Sending	-	-
RD	Receiving	-	-
ERR	Parameter error CRC error Station trouble	Normal	Changing parameters

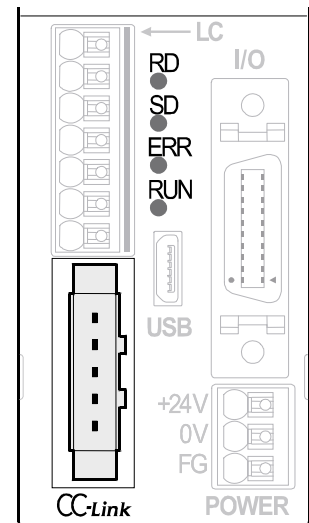

The CC-Link connector

DA	Signal line DA
DB	Signal line DB
DG	Signal ground
NC	Open terminal
SLD	Shield terminal

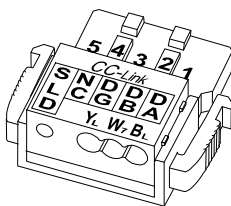

Accessory

3M 35505-6000-B0M GF

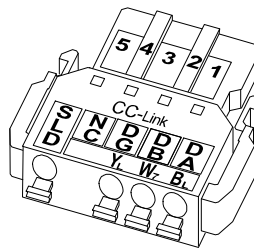

Spring type

3M 35A05-60S0-B0M GF

Illustration 15 The CC-Link connector

6.3.1. Address Map

Remote register (4 stations occupied)

In case of setting address to 1.

AD-4430C ⇒ Master				Master ⇒ AD-4430C		
Station No.	Remote register	Buffer	Description	Remote register	Buffer	Description
1	RWr0000	2E0	Net	RWw0000	1E0	SP1: Final
	RWr0001	2E1		RWw0001	1E1	
	RWr0002	2E2	Gross	RWw0002	1E2	SP2: Optional preliminary
	RWr0003	2E3		RWw0003	1E3	
2	RWr0004	2E4	Total weight (Net when finishing)	RWw0004	1E4	SP3: Preliminary
	RWr0005	2E5		RWw0005	1E5	SP4: Free fall
	RWr0006	2E6	Error code	RWw0006	1E6	SP5: Over
	RWr0007	2E7	Error sub code	RWw0007	1E7	SP6: Under
3	RWr0008	2E8	Weighing information 1	RWw0008	1E8	SP7: Full
	RWr0009	2E9		RWw0009	1E9	
	RWr000A	2EA	Weighing information 2	RWw000A	1EA	SP8: Near-zero
	RWr000B	2EB		RWw000B	1EB	
4	RWr000C	2EC	Command data reply	RWw000C	1EC	Command data
	RWr000D	2ED		RWw000D	1ED	
	RWr000E	2EE	Command No. reply	RWw000E	1EE	Command No.
	RWr000F	2EF	Not used (Reserved by inside)	RWw000F	1EF	Not used (Reserved by inside)

Remote register (2 stations occupied)

In case of setting address to 1.

AD-4430C ⇒ Master				Master ⇒ AD-4430C		
Station No.	Remote register	Buffer	Description	Remote register	Buffer	Description
1	RWr0000	2E0	Value (Net / Gross)	RWw0000	1E0	SP1: Final
	RWr0001	2E1		RWw0001	1E1	
	RWr0002	2E2	Error code	RWw0002	1E2	SP2: Optional preliminary
	RWr0003	2E3	Error sub code	RWw0003	1E3	
2	RWr0004	2E4	Command data response	RWw0004	1E4	Command data
	RWr0005	2E5		RWw0005	1E5	
	RWr0006	2E6	Command No. response	RWw0006	1E6	Command No.
	RWr0007	2E7	Not used (Reserved by inside)	RWw0007	1E7	Not used (Reserved by inside)

Remote register (1 station occupied)

In case of setting address to 1.

AD-4430C ⇒ Master				Master ⇒ AD-4430C		
Station No.	Remote register	Buffer	Description	Remote register	Buffer	Description
1	RWr0000	2E0	Value (Net / Gross)	RWw0000	1E0	Not used (Reserved by inside)
	RWr0001	2E1		RWw0001	1E1	
	RWr0002	2E2	Error code	RWw0002	1E2	
	RWr0003	2E3	Error sub code	RWw0003	1E3	

Station No.	AD-4430C ⇒ Master			Master ⇒ AD-4430C				
	Remote input	Buffer	Description	Remote output	Buffer	Description		
1	RX0000	0E0	Setpoints writing response flag	RY0000	160	Setpoints, request flag		
	RX0001		Not used (Reserved by inside)	RY0001		Not used (Reserved by inside)		
	RX0002		Command response flag	RY0002		Command request flag		
	RX0003		<u>Write</u> / Read response flag	RY0003		<u>Write</u> / Read selection flag		
	RX0004		Not used (Reserved by inside)			RY0004	Not used (Reserved by inside)	
	RX0005					RY0005		
	RX0006		CPU normal operation			RY0006		
	RX0007		Not used (Reserved by inside)			RY0007		
	RX0008		Decimal point 2 ⁰	3 bits Binary		RY0008		
	RX0009					RY0009		
	RX000A					RY000A		
	RX000B		Not used (Reserved by inside)			RY000B		
	RX000C					RY000C		
	RX000D					RY000D		
	RX000E					RY000E		
	RX000F					RY000F		
	RX0010	0E1			Near-zero	RY0010		Zero
	RX0011				Large flow	RY0011		Zero clear
	RX0012				Medium flow	RY0012		Tare
	RX0013		Small flow	RY0013	Tare clear			
	RX0014		Over	RY0014	Hold			
	RX0015		Final	RY0015	Net display			
	RX0016		Under	RY0016	Gross display			
	RX0017		Stable	RY0017	Printing command			
	RX0018		Weighing end	RY0018	Actual free fall input			
	RX0019		Capacity over	RY0019	One shot, Small flow			
	RX001A		Holding	RY001A	Error rest			
	RX001B		Full	RY001B	Restart			
	RX001C		In weighing sequence	RY001C	Batch start			
	RX001D		<u>Normal batch</u> / Discharge	RY001D	<u>Normal batch</u> / Discharge			
	RX001E		weighing sequence error	RY001E	Pause			
	RX001F		Weighing failure	RY001F	Emergency stop			

Station No.	AD-4430C ⇒ Master			Master ⇒ AD-4430C		
	Remote input	Buffer	Description	Remote output	Buffer	Description
2	RX0020 to RX003F	0E2 to 0E3	Not used (Reserved by inside)	RY0020 to RY003F	162 to 163	Not used (Reserved by inside)
3	RX0040	0E4	Not used (Reserved by inside)	RY0040	164	Not used (Reserved by inside)
	RX0041			RY0041		
	RX0042			RY0042		
	RX0043			RY0043		
	RX0044			RY0044		
	RX0045			RY0045		
	RX0046			RY0046		
	RX0047			RY0047		
	RX0048			RY0048		
	RX0049			RY0049		
	RX004A			RY004A		
	RX004B			RY004B		
	RX004C			RY004C		
	RX004D			RY004D		
	RX004E			RY004E		
	RX004F			RY004F		
	RX0050	0E5	User output 1	RY0050	165	User output 1
	RX0051		User output 2	RY0051		User output 2
	RX0052		User output 3	RY0052		User output 3
	RX0053		User output 4	RY0053		User output 4
	RX0054		User output 5	RY0054		User output 5
	RX0055		User output 6	RY0055		User output 6
	RX0056		User output 7	RY0056		User output 7
	RX0057		User output 8	RY0057		User output 8
	RX0058		User input 1	RY0058		Not used (Reserved by inside)
	RX0059		User input 2	RY0059		
	RX005A		User input 3	RY005A		
	RX005B		User input 4	RY005B		
RX005C	User input 5		RY005C			
RX005D	User input 6		RY005D			
RX005E	Not used (Reserved by inside)		RY005E			
RX005F			RY005F			

Station No.	AD-4430C ⇒ Master			Master ⇒ AD-4430C					
	Remote input	Buffer	Description	Remote output	Buffer	Description			
4	RX0060	0E6	Net over	RY0060	166	Not used (Reserved by inside)			
	RX0061		Net under	RY0061					
	RX0062		Gross over	RY0062					
	RX0063		Gross under	RY0063					
	RX0064		A/D over	RY0064					
	RX0065		A/D under	RY0065					
	RX0066		Center zero of net	RY0066					
	RX0067		Center zero of gross	RY0067					
	RX0068		In displaying net	RY0068					
	RX0069		In displaying gross	RY0069					
	RX006A		During tare	RY006A					
	RX006B		CAL operation error	RY006B					
	RX006C		Zero compensation error	RY006C					
	RX006D		Tare error	RY006D					
	RX006E		Error of displaying net	RY006E					
	RX006F		Linkage of display x	RY006F					
	RX0070		0E7	Not used (Reserved by inside)			RY0070	167	Not used (Reserved by inside)
	RX0071						RY0071		
	RX0072	RY0072							
	RX0073	RY0073							
	RX0074	RY0074							
	RX0075	RY0075							
	RX0076	RY0076							
	RX0077	RY0077							
	RX0078	Initial process request flag		RY0078	Initial process finish flag				
	RX0079	Initial data processing completion flag		RY0079	Initial data setting request flag				
	RX007A	Error status flag		RY007A	Error reset request flag				
	RX007B	Remote station READY flag		RY007B	Not used (Reserved by inside)				
	RX007C	Not used (Reserved by inside)		RY007C					
	RX007D			RY007D					
	RX007E			RY007E					
	RX007F			RY007F					

Station No.	AD-4430C ⇒ Master			Master ⇒ AD-4430C				
	Remote input	Buffer	Description	Remote output	Buffer	Description		
1	RX0000	0E0	Setpoints writing response flag	RY0000	160	Setpoints request flag		
	RX0001		Not used (Reserved by inside)	RY0001		Not used (Reserved by inside)		
	RX0002		Command response flag	RY0002		Command request flag		
	RX0003		<u>Write</u> / Read response flag	RY0003		<u>Write</u> / Read selection flag		
	RX0004		Not used (Reserved by inside)			RY0004	Not used (Reserved by inside)	
	RX0005					RY0005		
	RX0006		CPU normal operation			RY0006		
	RX0007		Not used (Reserved by inside)			RY0007		
	RX0008		Decimal point 2 ⁰	3bits Binary		RY0008		
	RX0009					RY0009		
	RX000A					RY000A		
	RX000B		Not used (Reserved by inside)			RY000B		
	RX000C					RY000C		
	RX000D					RY000D		
	RX000E					RY000E		
	RX000F					RY000F		
	RX0010	0E1			Near-zero	RY0010		Zero
	RX0011				Large flow	RY0011		Zero clear
	RX0012				Medium flow	RY0012		Tare
	RX0013		Small flow	RY0013	Tare clear			
	RX0014		Over	RY0014	Hold			
	RX0015		Final	RY0015	Net display			
	RX0016		Under	RY0016	Gross display			
	RX0017		Stable	RY0017	Printing command			
	RX0018		Weighing end	RY0018	Actual free fall input			
	RX0019		Capacity over	RY0019	One shot, Small flow			
	RX001A		Holding	RY001A	Error rest			
	RX001B		Full	RY001B	Restart			
	RX001C		In weighing sequence	RY001C	Batch start			
	RX001D		<u>Normal batch</u> / Discharge	RY001D	<u>Normal batch</u> / Discharge			
	RX001E		weighing sequence error	RY001E	Pause			
	RX001F		Weighing failure	RY001F	Emergency stop			

Station No.	AD-4430C ⇒ Master			Master ⇒ AD-4430C				
	Remote input	Buffer	Description	Remote output	Buffer	Description		
2	RX0020	0E2	Net over	RY0020	162	Not used (Reserved by inside)		
	RX0021		Net under	RY0021				
	RX0022		Gross over	RY0022				
	RX0023		Gross under	RY0023				
	RX0024		A/D over	RY0024				
	RX0025		A/D under	RY0025				
	RX0026		Center zero of net	RY0026				
	RX0027		Center zero of gross	RY0027				
	RX0028		In displaying net	RY0028				
	RX0029		In displaying gross	RY0029				
	RX002A		During tare	RY002A				
	RX002B		CAL operation error	RY002B				
	RX002C		Zero compensation error	RY002C				
	RX002D		Tare error	RY002D				
	RX002E		Error of displaying net	RY002E				
	RX002F		Linkage of display x	RY002F				
	RX0030		0E2	Not used (Reserved by inside)			RY0030	163
	RX0031	RY0031						
	RX0032	RY0032						
	RX0033	RY0033						
	RX0034	RY0034						
	RX0035	RY0035						
	RX0036	RY0036						
	RX0037	RY0037						
	RX0038	Initial process request flag			RY0038	Initial process finish flag		
	RX0039	Initial process finish flag			RY0039	Initial process request flag		
	RX003A	Error status flag			RY003A	Error reset request flag		
	RX003B	Remote station READY			RY003B	Not used (Reserved by inside)		
	RX003C	Not used (Reserved by inside)			RY003C			
	RX003D				RY003D			
	RX003E				RY003E			
	RX003F				RY003F			

Station No.	AD-4430C ⇒ Master			Master ⇒ AD-4430C		
	Remote input	Buffer	Description	Remote output	Buffer	Description
1	RX0000	0E0	Near-zero	RY0000	160	Zero
	RX0001		Large flow	RY0001		Zero clear
	RX0002		Medium flow	RY0002		Tare
	RX0003		Small flow	RY0003		Tare clear
	RX0004		Over	RY0004		Hold
	RX0005		Final	RY0005		Net display
	RX0006		Under	RY0006		Gross display
	RX0007		Stable	RY0007		Printing command
	RX0008		Weighing end	RY0008		Actual free fall input
	RX0009		Capacity over	RY0009		One shot, Small flow
	RX000A		Holding	RY000A		Error rest
	RX000B		Full	RY000B		Restart
	RX000C		In weighing sequence	RY000C		Batch start
	RX000D		Normal batch / Discharge	RY000D		Normal batch / Discharge
	RX000E		weighing sequence error	RY000E		Pause
	RX000F		Weighing failure	RY000F		Emergency stop
	RX0010		0E1	Not used (Reserved by inside)		RY0010
	RX0011	RY0011				
	RX0012	RY0012				
	RX0013	RY0013				
	RX0014	RY0014				
	RX0015	RY0015				
	RX0016	RY0016				
	RX0017	RY0017				
	RX0018	Initial process request flag		RY0018	Initial process finish flag	
	RX0019	Initial process finish flag		RY0019	Initial process request flag	
	RX001A	Error status flag		RY001A	Error reset request flag	
	RX001B	Remote station READY		RY001B		
	RX001C	Not used (Reserved by inside)		RY001C	Not used (Reserved by inside)	
	RX001D			RY001D		
	RX001E			RY001E		
	RX001F		RY001F			

Numerical Form of Remote Register

Numerical number is hexadecimal. Negative numbers are indicated with 2's complement numbers.

Decimal	Hexadecimal (16 bits)	Hexadecimal (24 bits)	Hexadecimal (32 bits)
-10	FFF6	FFFFFF6	FFFFFFFF6
-1	FFFF	FFFFFFF	FFFFFFFFF
0	0000	000000	00000000
1	0001	000001	00000001
10	000A	00000A	0000000A

Writing Prohibition of Internal Reservation Area

The item "Not used (Reserved by inside)" on tables of the remote register and remote I/O is internal reservation. Writing this item is inhibited. When inputting anything into the remote output (RY) and remote register (RWw), a malfunction may occur. Values of the internal reservation remote input (RY) and remote register (RWw) are indefinite.

Error Codes

Error Code	Error flag	(Instrument error)
0	no error	
1	A/D error	(Module error)
2	EEPROM error	(Writing error)
3	RAM error	(Reading & Writing error)
4	Calibration error	(Calibration data error)
5	Weighing error	(Mode error)
6	Self-check error	(Performing self-check)

- Error code and Error status flag (RX007A) are not reset automatically. Reset the "Error flag (RX007A)" of "6.3.3. Timing Chart".

Weighing Errors

Net over
Net under
Gross over
Gross under
A/D over
A/D under
Zero compensation error
Tare error
Net display error
CAL operation error

- Weighing failure will turn ON when either over, under or operation error occur.
- Operation error is cleared when operation is performed normally.

6.3.2. Commands

Command No.	Command data	Description	Writing	Reading
0	1	Zero	○	×
	2	Zero clear	○	×
	3	Tare	○	×
	4	Tare clear	○	×
	5	Hold	○	×
	6	Net display	○	×
	7	Gross display	○	×
	8	Printing command	○	×
	9	F key	○	×
	21	Normal batch weighing	○	×
	22	Loss in weight	○	×
	23	Batch start	○	×
	24	Pause	○	×
	25	Restart	○	×
	26	Error reset	○	×
	27	Actual free fall input	○	×
	28	One shot, Small flow	○	×
	81	Self check, start	○	×
	82	Self check, stop	○	×
	91	CAL zero mode	○	×
92	CAL span mode	○	×	
93	CAL end	○	×	
94	CAL zero setting	○	×	
95	CAL span setting	○	×	
101	-	Program version	×	○
102	-	Serial No.(lower 5 digits)	×	○
103	-	Program checksum	×	○
104	-	FRAM checksum	×	○
201	-	Gross count	×	○
202	-	Net count	×	○
203	-	Tare count	×	○
204	-	Load cell output. Scale : 1 nV/V	×	○
205	-	Load cell output. Scale : 10 nV/V	×	○
206	-	Flow rate (per second)	×	○
301	-	Sequence No.	×	○
302	-	Batch weighing error	×	○
303	-	Actual free fall	×	○
304	-	Free fall (average)	×	○
305	-	Free fall coefficient (average)	×	○
306	-	Flow rate (when small flow is OFF)	×	○
307	-	Result of batch weighing	×	○
Function code	parameter	Function	○	○

6.3.3. Timing Chart

Example assumes that station No. is 1 and remote registers are occupied 4 stations.

1. Turning on the Display

1. Turn on the AD-4430C. When the CC-Link can communicate, the "Initial process request flag (RX0078)" is turned on.
 2. At the master station, checks, initialize and turn on the "Initial process finish flag (RY0078)".
 3. The AD-4430C turns off the "Initial process request flag (RX0078)" and turns on the "Remote station READY flag (RX007B)".
 4. Turn off the "Initial process finish flag (RY0078)" at the master station.
- When "0 : not needed" is set to "CC 04 initial process" of "5.4.10. The Function Related to the CC-Link", the initial process is skipped and "Remote station READY (RX007B)" turns on.

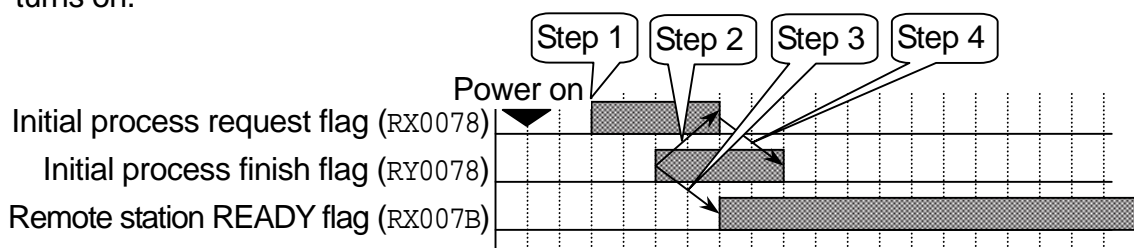

Illustration 16 Turning on the display

2. Resuming Weighing Mode from Suspended Modes

Because the weighing stops and a correct weighing value is not gotten, the remote station READY flag (RX007B) is turned off in the calibration mode and in off mode (OFF state, standby). The way to resume weighing mode is the same as the process to turn on the AD-4430C.

Example 3. Requesting Initialization from Master Station

1. In case of requesting the "Initial setting request of the AD-4430C from the master station, while turning on the "Remote station READY flag (RX007B)", turn on the "Initial process request flag (RY0079)".
2. The AD-4430C turns off the "Remote station READY flag (RX007B)" and performs initial settings.
3. When finishing the initial setting, the AD-4430C turns on the "Initial data processing completion flag (RX0079)".
4. Turn off the "Initial data setting request flag (RY0079)" by the master station.

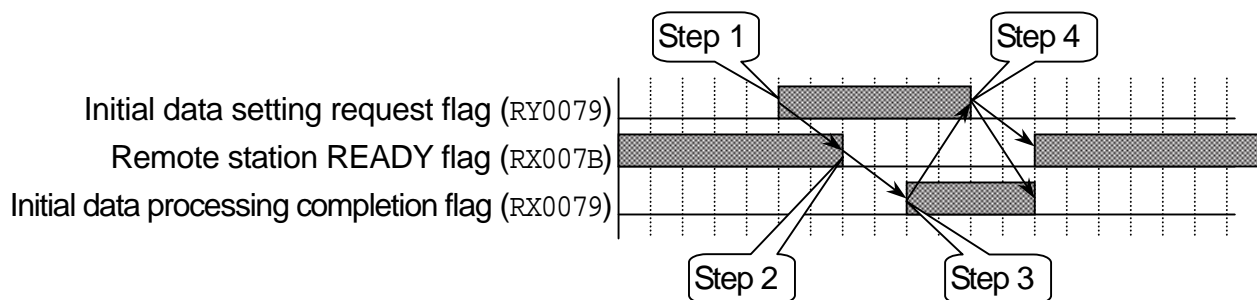

Illustration 17 Requesting initialization from master station

4. Inputting Setpoints (Basic Comparator Parameter)

- Setpoints (Basic comparator parameters) can be input into the AD-4430C using the remote register (RWw0000 to RWw000B) collectively.
- 1. Store setpoints to the remote register (RWw0000 to RWw000B).
Turn on the "Setpoint request flag (RY0000)".
- 2. Turn off the "Setpoint request flag (RY0000)" after turning on the "Setpoint writing flag (RX0000)".

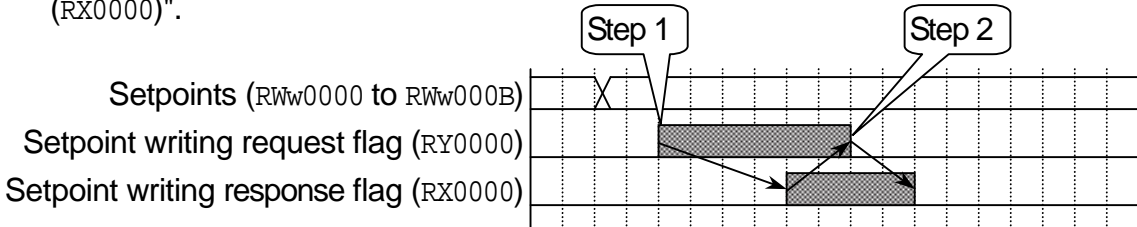

Illustration 18 Inputting setpoints (Basic comparator parameters)

5. Reading Command

1. Select the type of data at the command No. (RWw000E) of remote register.
2. The output data is stored at the command data (RWw000C to RWw000D) of remote register.

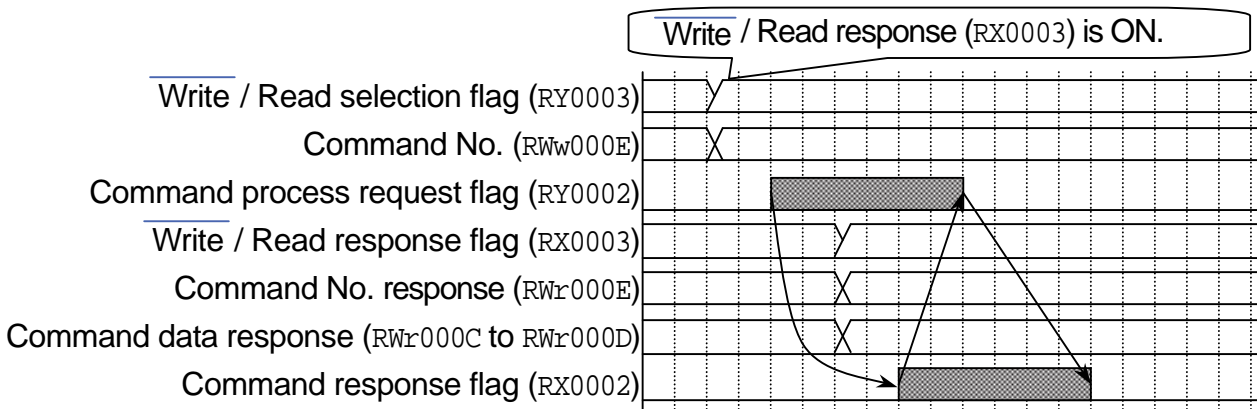

Illustration 19 Reading command

6. Writing Command

1. Select the type of data at the command No. (RWw000E) of remote register.
2. Place the writing data at the command data (RWw000C to RWw000D) of remote register.

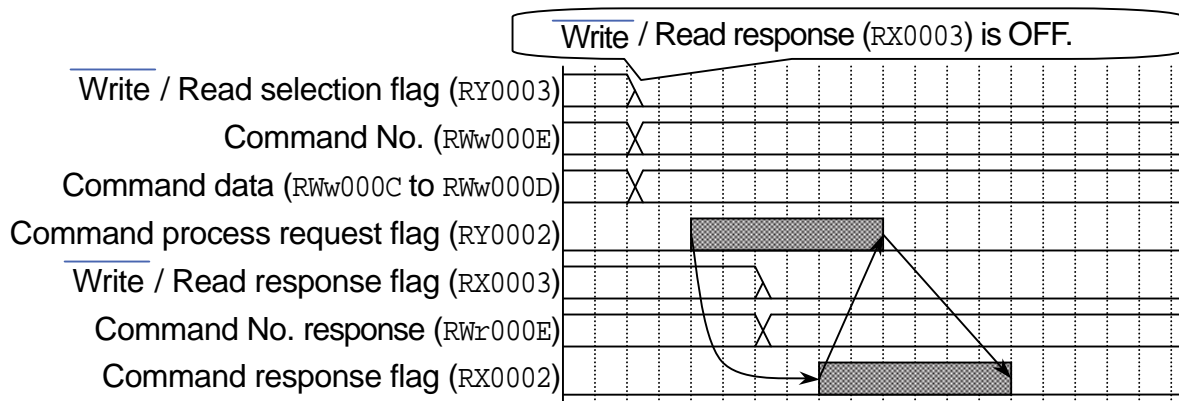
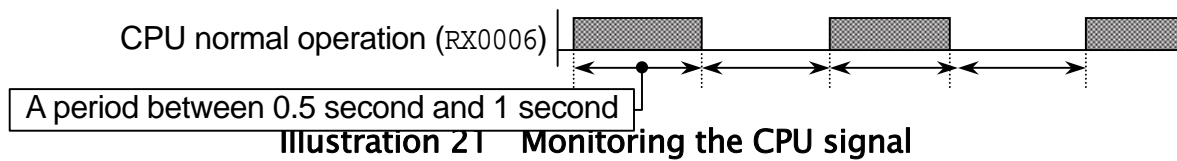

Illustration 20 Writing command

7. Monitoring the CPU Signal at Normal Operation

When the AD-4430C indicator status is normal, the following CPU normal operation flag (RX0006) is output. It alternates in a period between 0.5 second and 1 second.



8. Resetting Error Status Flag

1. When an error is detected, the remote station READY flag (RX007B) is turned off, the error status (RX007A) turns on, and the error status is informed to the master station.
2. The master station requests to reset the error status flag (RX007A) using the error reset request flag (RY007A).

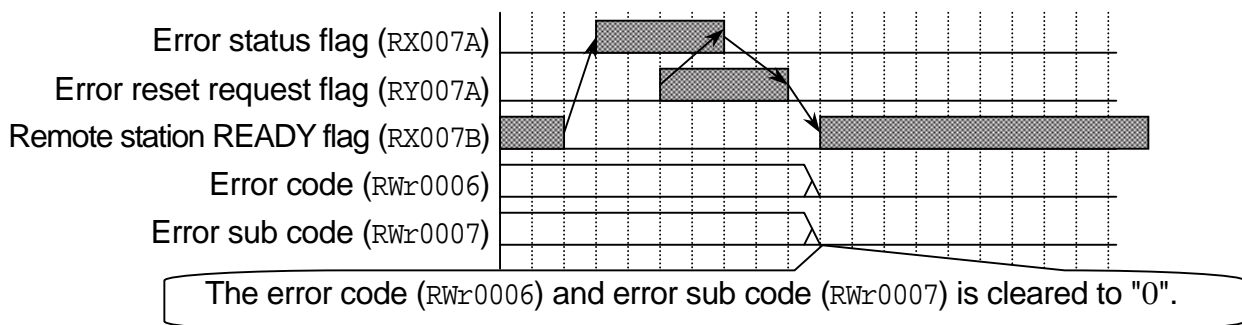

6.3.4. The Calibration

The AD-4430C can perform the calibration using the CC-Link commands (that consists of command data (RWw000C to RWw000D) and command No.(RWw000E) of the remote register). Refer to section "6.3.2. Commands" for the detail of these commands of the CC-Link. In the following steps, all command No. (RWw000E) of the remote register is 0.

- | | | |
|---------------|--|---------------------------------------|
| Step 1 | CAL zero mode
The AD-4430C displays [CAL 0] and enters the CAL zero input mode. | Command data (RWw000C to RWw000D): 91 |
| Step 2 | CAL zero setting
The input voltage at zero point (C-F17) is updated when a command is received.
The AD-4430C proceeds to CAL span input mode. | Command data (RWw000C to RWw000D): 94 |
| Step 3 | CAL span mode
The AD-4430C displays [-SPn] and enters the CAL span input mode. | Command data (RWw000C to RWw000D): 92 |
| Step 4 | CAL span setting
The span input voltage (C-F18) is updated when a command is received.
The AD-4430C returns to weighing mode. | Command data (RWw000C to RWw000D): 95 |
| Step 5 | CAL end
The AD-4430C displays [-End] and returns to weighing mode. | Command data (RWw000C to RWw000D): 93 |
- Specify the weight against span Input voltage (**C-F19**) on the function related to the calibration ([-Fnc]).

6.3.5. Self-Check

The connections of the load cell can be verified using the CC-Link command. Refer to section "6.3.2. Commands" for the detail of these commands of the CC-Link. In the following steps, all command No. (RWw000E) of the remote register is 0.

- Step 1 Input the command to start self check. Command data (RWw000C to RWw000D): 81
The AD-4430C enters the self check mode and start the scan. (self check error)
- Step 2 Input the command to stop self check Command data (RWw000C to RWw000D): 82
The AD-4430C stops the self check mode and returns to weighing mode.
- Step 3 Input error reset request flag. Error reset request flag
The AD-4430C resets self check error flag.

The AD-4430C sums up the result of the self check and outputs it to error sub code (RWr0007). There is no error, the error sub code is 0. (The undiagnosed item is regarded as error.) Refer to "7.2.1. Guideline to Verify the Load Cell Connections" for the details of diagnostic point and check criteria. Refer to "7.2.5. Display and Output of Verification" for display and output of self check.

Self Check Item	Error code
Power supply voltage for load cell	1
SEN+ voltage	2
SEN- voltage	4
Output voltage of load cell	8
Output value of load cell	16
SIG+ voltage	32
SIG- voltage	64
Internal temperature	128

6.3.6. Function Settings

- The monitoring and changing of the function settings uses the "5. Reading Command" and "6. Writing Command" in the "6.3.3. Timing Chart".

Monitoring the Function Settings

Set the function code to command No. (RWw000E) using the "5. Reading Command".
Read data of the command data response (RWr000C to RWr000D)

Changing the Function Settings

Set the function code to command No. (RWw000E) using the "6. Writing Command".
Write data into the command data (RWw000C to RWw000D)

- Refer to the following sections for the function code.
 - "5.3.6. The Function Related to the Calibration ($E-F_{nc}$)",
 - "5.3.7. The Function Related to the Linearization Function ($L-F_{nc}$)",
 - "5.4.4. The Function Related to the Basics Function ($F_{nc} F$)" to
 - "5.4.10. The Function Related to The CC-Link ($EE F$)"

6.4. USB (RS-232C)

- The function settings can be input and output from a device that is connected to the Micro-B USB connector.
- Communication parameters are fixed.
Baud rate: 9600 bps, Data bits: 7 bits, Even parity, Terminator: <CR><LF>
The communication tool can download the appropriate software from A&D home page.
- In weighing, do not connect the cable. It may be easily influenced by environmental noise.
- Use the standard Micro-B USB connector.
- The reading and writing of the function from the USB is effective except the weighing mode. (OFF mode (Standby), Function mode, Calibration mode, Self-check mode, etc.)

6.4.1. Format

Monitoring Command

Function code (4 figures) Terminator

Example of the near-zero

Command

1	2	0	8	CR	LF
---	---	---	---	----	----

Function code (4 figures) Data (7 figures) Terminator

Response

1	2	0	8	,	+	0	0	0	0	1	0	CR	LF
---	---	---	---	---	---	---	---	---	---	---	---	----	----

Storing Command and Response

Function code (4 figures) Data (7 figures) Terminator

Example of the near-zero

Command

1	2	0	8	,	+	0	0	0	0	1	0	CR	LF
---	---	---	---	---	---	---	---	---	---	---	---	----	----

Function code (4 figures) Data (7 figures) Terminator

Response

1	2	0	8	,	+	0	0	0	0	1	0	CR	LF
---	---	---	---	---	---	---	---	---	---	---	---	----	----

- The response of the monitoring command is the same as the storing command.
- "+999999" means an irregular response. Ex.: In case that the function code is not correct and the command is not perform.

6.4.2. Monitoring the Function Setting

It specifies a function code in the command code and monitors the data.

Command

N	N	N	N	CR	LF
---	---	---	---	----	----

Response

N	N	N	N	,	±	X	X	X	X	X	X	CR	LF
---	---	---	---	---	---	---	---	---	---	---	---	----	----

NNNN is code, ±XXXXXX is numerical number.

6.4.3. Storing the Function Setting

It specifies a function code in the command code and stores the data.

Command

N	N	N	N	,	±	X	X	X	X	X	X	CR	LF
---	---	---	---	---	---	---	---	---	---	---	---	----	----

Response

N	N	N	N	,	±	X	X	X	X	X	X	CR	LF
---	---	---	---	---	---	---	---	---	---	---	---	----	----

NNNN is code, ±XXXXXX is numerical number.

- In case of parameter type, store branch number.
- **Fnc01** (Key switch disable) is a decimal.

6.4.4. Monitoring the Whole Function Settings

Functions of all can be monitored at once. It can make a list of functions.

Command

N	N	N	N	CR	LF
---	---	---	---	----	----

NNNN is command.

Command code	Description
0999	All functions related
1000	Calibration related
1100	Linearity related
1200	Basic function related
1300	Hold function related
1400	Weighing sequence related
1500	Setpoint related
1600	Control I/O related
1700	Standard serial output related
1800	CC-Link related

6.4.5. Monitoring Each Piece of Data

Each function can be monitored.

Command

N	N	N	N	CR	LF
---	---	---	---	----	----

NNNN is command.

Command code	Description
0101	Program version
0102	Serial No.(lower 5 digits)
0103	Program checksum
0104	FRAM checksum
0201	Gross count
0202	Net count
0203	Tare count
0204	Load cell output. Scale : 1 nV/V
0205	Load cell output. Scale : 10 nV/V
0206	Flow rate (per second)

7. Maintenance

7.1. Error Messages

If an error message is displayed, use the following countermeasure.

Error message	Cause	Countermeasure
$E5 Er$	Program checksum error	Repairer is required.
$Ad Er$	Data can not be acquired from the A/D converter.	Repairer is required.
$FrREr$	Correct data can not be read from the nonvolatile memory (FRAM).	Initialize the module. If not be resolved, repairer is required.
$E Err$	Calibration data is incorrect.	Perform the calibration
$E Er x$	Calibration error.	Refer to "5.3.8. Error Codes for the Calibration". x : numerical.
$Errdt$	The setting value is out of range.	Check the setting value.

7.2. Verifying the Load Cell Connections (DIAGNOS)

7.2.1. Guideline to Verify the Load Cell Connections

The faulty wiring or disconnection of the load cell can be checked using the AD-4430C. This verification is useful for new settings, pre-measurement inspections and periodic inspections.

No.	Diagnostic item	Diagnostic point	Judgment Criteria (Generally)	Error code
1	Load cell input voltage	Between SEN+ ↔ SEN-	3 V or more	1
2	SEN+ voltage	Between SEN+ ↔ AGND	4 V or more	2
3	SEN- voltage	Between SEN- ↔ AGND	1 V or less	4
4	Load cell output voltage	Between SIG+ ↔ SIG-	Within ±35 mV	8
5	Load cell output rate	Between SIG+ ↔ SIG-	Within ±7 mV/V	16
6	SIG+ voltage	Between SIG+ ↔ AGND	1 V to 4 V	32
7	SIG- voltage	Between SIG- ↔ AGND	1 V to 4 V	64
8	Internal temperature		-20 °C to +60 °C	128

AGND : Internal analog circuit ground
 EXC- : Load cell excitation voltage (-)
 EXC+ : Load cell excitation voltage (+)
 SIG- : Load cell output (-)
 SIG+ : Load cell output (+)

SHLD : Shield. Frame ground.
 SEN- : Sensing input (-)
 SEN+ : Sensing input (+)

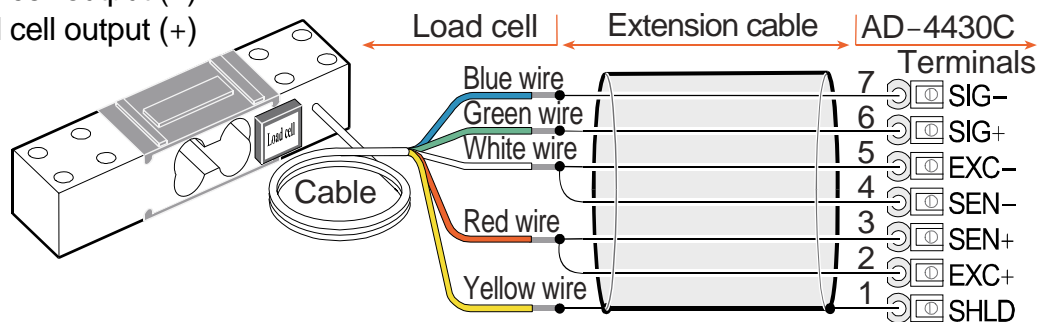

Illustration 23 Wire name of load cell

7.2.2. Verifying Load Cell Connections with Switch Operation

- Step 1** Press the **F** key while pressing and holding the **ENT** key (**ENT** + **F**) to display **Fnc**. Press the **ENT** key to enter to the function mode.
To return to the weighing mode, press the **ESC** key.
- Step 2** Press the **→** key while pressing and holding the **ENT** key (**→** + **ENT**) to display **CHc** of the check mode. Press the **ENT** key to display the check item.
- Step 3** Select the self-check mode **d,RC** using the **↑** key. Press the **ENT** key to enter to it. The selected check is performed and displayed the results for approx. 16 seconds. Each measurement value can be displayed using the **↑** key.

7.2.3. Verifying Load Cell Connections with the CC-Link

The connections of the load cell can be verified using the CC-Link command.

Refer to section "6.3.2. Commands" for the detail of these commands of the CC-Link. In the following steps, all command No. (RWw000E) of the remote register is 0.

- Step 1** Input the command to start the self check. Command data (RWw000C to RWw000D): 81
The AD-4430C enters to the self check mode and start the scan. (self check error)
The result is stored in the error sub code (RWx0007).
- Step 2** Input the command to stop the self check Command data (RWw000C to RWw000D): 82
The AD-4430C stops the self check mode and returns to weighing mode.
The CC-Link outputs the diagnose result of self check error directly.
- Step 3** Input error reset request flag. Error reset request flag
The AD-4430C resets self check error flag.
- The status of the CC-link is the same as the status of "Verifying Load Cell Connections with the CC-Link". Request an error reset and reset error.

7.2.4. Verifying Using the Control I/O

- Step 1** When the input terminal of the control I/O set to "diagnose" remains "ON" for 1 second or more, the AD-4430C enters the diagnostic mode and starts the scan.
- Step 2** When turning off the input terminal of the control I/O set to "diagnose", the AD-4430C stops the diagnostic mode and returns to the weighing mode.

7.2.5. Display and Output of Verification

Total value of error codes is output to the error sub code (RWr0003) in the CC-Link. Items that have not been diagnosed are also totaled as errors. Refer to "7.2.1. Guideline to Verify the Load Cell Connections" concerning the detail of the diagnose point and judgment criteria.

When scanning and changing items, d,RC is displayed and 99999 is output. The diagnostic result of the scanning are displayed and output as a code *XXX* in which error codes are accumulated.

If there are no errors, Good is displayed and 00000 is output.

If there is an error, ErXXX is displayed and 00XXX is output.

The resistance of the load cell cable is calculated with the following formula :
 (Resistance of Load cell) x (SEN- voltage) / (Load cell input voltage)

No.	Check item	Status LED	Display Range	Error Code
		G N H S Z X		
1	Load cell excitation voltage	● ● ● ● ● ●	0.001 V	1
2	SEN+ voltage	● ● ● ● ● ●	0.001 V	2
3	SEN- voltage	● ● ● ● ● ●	0.001 V	4
4	Load cell output voltage	● ● ● ● ● ●	0.001 mV	8
5	Load cell output rate	● ● ● ● ● ●	0.0001 mV/V	16
6	SIG+ voltage	● ● ● ● ● ●	0.001 V	32
7	SIG- voltage	● ● ● ● ● ●	0.001 V	64
8	Internal temperature	● ● ● ● ● ●	0.1 °C	128

● : Lit, ○ : Not lit

7.3. Check Mode

The check mode can be used to check the performance of the display, key switches and external I/O.

7.3.1. Entering to the Check Mode

- Step 1** Press the **[F]** key while pressing and holding the **[ENT]** key (**[ENT]** + **[F]**) to display **[Fnc]**. To return to the weighing mode, press the **[ESC]** key.
- Step 2** Press the **[→]** key while pressing and holding the **[ENT]** key (**[→]** + **[ENT]**) to display **[Hc]** of the check mode. Press the **[ENT]** key to display the check item.
- Step 3** Select the check item using the **[↑]** key. Press the **[ENT]** key to enter to it. Press the **[ESC]** key when exiting it.

Display symbol	Item
<i>[HKEY]</i>	Key check
<i>[H I/O]</i>	Control I/O check
<i>[H CL]</i>	Standard serial output check
<i>[H CC]</i>	CC-Link check
<i>[H Ad]</i>	A/D converter output check (Load cell check)
<i>[H in]</i>	Internal count check
<i>[HP-r9]</i>	Program version
<i>[H Sn]</i>	Serial number
<i>[SP-r9]</i>	Program checksum
<i>[SF-rA]</i>	Memory checksum
<i>[F dt]</i>	CALF check (C-F01 to C-F28)

7.3.2. Verifying the Switch Operation

When pressing the key, the corresponding segment moves. "8" & "0".
If stopping the current check mode, press the **[ESC]** key twice.

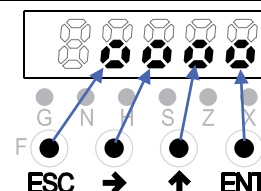

7.3.3. Checking the Control I/O

When displaying the terminal number of the control I/O in order, its output turns on in order. When turning on the input of the control I/O, its LED lights.

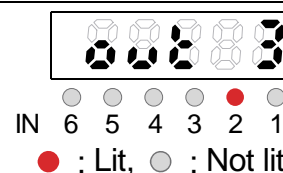

7.3.4. Checking the Serial Communication

Test data "ST,GS,+00000.0kg<CR><LF>" is output using a preset baud rate when the **[ENT]** key is pressed every time.

7.3.5. Checking the CC-Link

The status of the CC-Link communication can be monitored.
The remote register (R_Ww0000 to R_Ww0001) can be monitored.
When 4 stations are used, net value is displayed.
When 2 stations or 1 station are used, the display accords with data output (CC 05).
The initialization request can be sent to the master station with the **ENT** key.

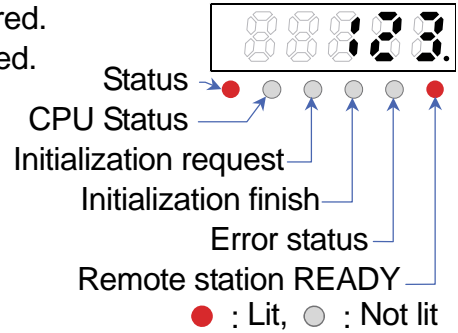

7.3.6. Monitoring the A/D Converter (for Load Cell Output)

The voltage output rate of the load cell is displayed in unit of mV/V .
Example : When the internal counts is 1.2345 mV/V and the output

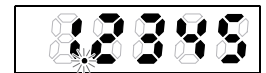

rate is above ± 7 mV/V, a damage or a connection error of the load cell may be cause. Refer to "7.5. Verifying the Load Cell Connections Using Multimeter".

7.3.7. Monitoring the Internal Value

The current internal count (10 times of weighing value) is displayed.
When the internal count is 123, the example display is as follows:

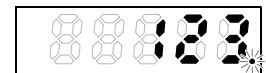

7.3.8. Monitoring the Program Version

Program version is displayed. Example : Version 1.00 is as follows:

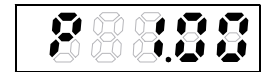

7.3.9. Monitoring the Serial Number

Last five digits of serial number is displayed.

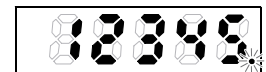

7.3.10. Monitoring the Checksum of the Program

Checksum of the program is displayed. Example : Checksum is EF.

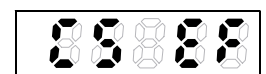

7.3.11. Monitoring the Checksum of an Internal FRAM

Checksum of FRAM is displayed. Memory of the general function is not checked. Example : Checksum is EF.

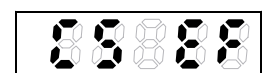

7.3.12. Displaying Function Parameters for the Calibration

The function related to the calibration can be displayed.

- Refer to "5.3.6. The Function Related to the Calibration" for operation and details.
- Parameters can not be changed here.

7.4. Initializing Parameters

The initialization mode restores the parameters of the default values to the FRAM. Three types of initialization mode are available as shown below.

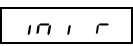
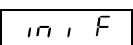
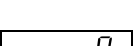
Initialization mode	Display	Description
RAM initialization		RAM memory is initialized. The center of zero and tare value will be restored to 0.
General functions initialization		Data of the general functions stored in the FRAM are reset to factor settings.
All data initialization		All data stored in the FRAM are initialized. Data related to calibration is also initialized, so calibration must be performed again.

7.4.1. Initializing Mode for RAM and Function Parameters

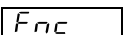
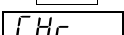
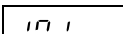
- Step 1** Press the **F** key while pressing and holding the **ENT** key (**ENT** + **F**) to display . To return to the weighing mode, press the **ESC** key.
- Step 2** Press the **→** key while pressing and holding the **ENT** key (**→** + **ENT**) to display  of the check mode.
- Step 3** Select the initialization mode  using the **↑** key. Press the **ENT** key.
- Step 4** Select an item to be initialized using the **↑** key. Press the **ENT** key.
- Step 5** Check that all LED status are blinking.
If performing the initialization, press the **ENT** key for 3 seconds or more.
After initialization, all segments light and return to the weighing mode.
If canceling the initialization, press the **ESC** key return to the weighing mode.

7.4.2. Initializing the Whole Data

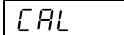
- Step 1** In the OFF mode (Standby: While turning off the module), Press **F** + **ENT** key to display  of the calibration mode.
To return to the weighing mode, press the **ESC** key.
- Step 2** Press the **ENT** key to enter to the calibration mode.
- Step 3** Select all initialization mode using the **↑** key. Press the **ENT** key.
- Step 4** Check that all LED status are blinking.
If performing the initialization, press the **ENT** key for 3 seconds or more.
After initialization, all segments light and return to the weighing mode.
If canceling the initialization, press the **ESC** key return to the weighing mode.

7.5. Verifying the Load Cell Connections Using Multimeter

The load cell connection can be checked easily using a digital multimeter.

The measurement points of the load cell connection are as follows :

When a summing box is used, the same measurement points inside of it must be measured.

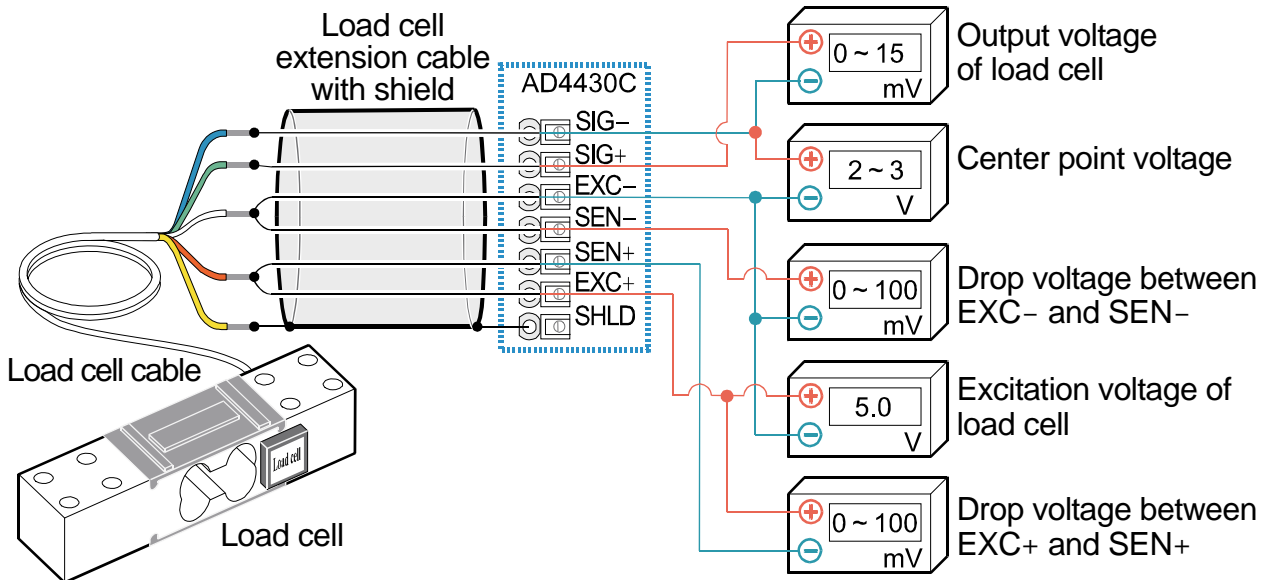

Illustration 24 Connection check of load cell

7.5.1. Check List of the Load cell Connections

Measurement points	Description	Judgment
EXC+ SEN+	A drop voltage of cable on EXC+ side.	Normally it is 100 mV or less. However, it may exceed 1V when an extremely long load cell cable is used. For the 4-wire connection, it must be 0 V.
SEN- EXC-	A drop voltage of cable on EXC- side.	
EXC+ EXC-	Input voltage	Normal range is between 4.75 V to 5.25 V.
SIG- EXC-	Center point voltage	It is approximately 2.5 V of a half of excitation voltage.
SIG+ SIG-	Output voltage	Generally it is within 0 V to 15 mV. Theoretical value is calculated from the load cell rated capacity, actual load and excitation voltage.

When the module does not operate properly, write the required items in the table below and contact your local A&D dealer.

Item	Usage circumstances, model number, rated, measurement value etc.	Note
Connection method	<input type="checkbox"/> 4-wire connection <input type="checkbox"/> 6-wire connection	When using the 4-wire connection, connect between EXC+ and SEN+ and between EXC- and SIG-.
Model name & number		
Rated capacity	[Unit]	
Rated output	[mV/V]	
Allowable overload	[%]	
The number of load cells used	[pieces]	
Use of summing box		
Length of the extension cable	[m]	Length between the module and the summing box.
Initial load of weighing module	[Unit]	
Minimum division of weighing module	[Unit]	All digits including decimal figures. Ex: 0.002kg
Capacity of weighing module	[Unit]	All digits including decimal figures. Ex: 10.000kg
Output of load cell using initial load	[mV/V]	Between -0.1mV/V and rated sensitivity of load cell (using initial load)
Output of load cell using capacity or arbitrary load.	Load cell output at Load [Unit] [mV/V]	When loaded to capacity, the output value of the initial load + the rated output value of the load cell. (It must be within allowable overload.)

Measurement points		Measurement contents	Measurement result
EXC+	SEN+	A drop voltage of cable on EXC+ side.	[mV]
EXC+	EXC-	Input voltage	[V]
SEN-	EXC-	A drop voltage of cable on EXC- side.	[mV]
SIG-	EXC-	Center point voltage	[V]
SIG+	SIG-	Output voltage	[mV]

7.6. The Parameter List For The Function

When performing maintenance, use the following list as a memorandum.

When making inquiries about the product, inform your local A&D dealer of the user settings.

7.6.1. The Function Related to the Calibration ($C-F_{nc}$)

Item Name	Function code	Description, Range and Default value	User setting
C-F01 Unit	1001	0: No used 1: g 2: kg 3: t 4: N 5: kN	
C-F02 Decimal point position	1002	0: 0 1: 0.0 2: 0.00 3: 0.000 4: 0.0000	
C-F03 Minimum division	1003	1: 1 2: 2 3: 5 4: 10 5: 20 6: 50	
C-F04 Maximum capacity	1004	1 to 70000 to 99999	
C-F05 Zero range	1005	0 to 2 to 100	
C-F06 Zero tracking time	1006	0.0 to 5.0	
C-F07 Zero tracking band	1007	0.0 to 9.9	
C-F08 Stability detection time	1008	0.0 to 1.0 to 9.9	
C-F09 Stability detection band	1009	0 to 2 to 9	
C-F10 Tare and zero at unstable weight value	1010	0: Disables both functions. 1: Enables both functions.	
C-F11 Tare when the gross weight is negative	1011	0: Disables tare. 1: Enables tare.	
C-F12 Output when out of range and unstable	1012	0: Disables output. 1: Enables output.	
C-F13 Exceeding negative gross weight	1013	1: Gross weight < -99999 2: Gross weight < Negative maximum capacity 3: Gross weight < -19d	
C-F14 Exceeding negative net weight	1014	1: Net weight < -99999 2: Net weight < Negative maximum capacity	
C-F15 Clear the zero value	1015	0: Disables. 1: Enables.	
C-F16 Zero setting when power is turned on	1016	0: Not used. 1: Use.	

Item Name	Function code	Description, Range and Default value	User setting
C-F17 Input voltage at zero	1017	-7.0000 to <input type="text" value="0.0000"/> to 7.0000	
C-F18 Span input voltage	1018	0.0100 to <input type="text" value="3.2000"/> to 9.9999	
C-F19 Weight against span Input voltage	1019	1 to <input type="text" value="32000"/> to 99999	
C-F26 Gravity acceleration of the calibration place	1026	9.7500 to <input type="text" value="9.8000"/> to 9.8500	
C-F27 Gravity acceleration of use place	1027	9.7500 to <input type="text" value="9.8000"/> to 9.8500	
C-F28 Suppression of the hold function	1028	<input type="text" value="0"/> : Permission. 1: Prohibition.	

7.6.2. The Function Related to the Linearization Function (L-Fnc)

Item Name	Function code	Description, Range and Default value	User setting
L-F01 Number of input points	1101	<input type="text" value="0"/> to 5	
L-F02 Linear-zero	1102	-7.0000 to <input type="text" value="0.0000"/> to 7.0000	
L-F03 Setting value for linear 1	1103	<input type="text" value="0"/> to 99999	
L-F04 Span at linear 1	1104	<input type="text" value="0.0000"/> to 9.9999	
L-F05 Setting value for linear 2	1105	<input type="text" value="0"/> to 99999	
L-F06 Span at linear 2	1106	<input type="text" value="0.0000"/> to 9.9999	
L-F07 Setting value for linear 3	1107	<input type="text" value="0"/> to 99999	
L-F08 Span at linear 3	1108	<input type="text" value="0.0000"/> to 9.9999	
L-F09 Setting value for linear 4	1109	<input type="text" value="0"/> to 99999	
L-F10 Span at linear 4	1110	<input type="text" value="0.0000"/> to 9.9999	

7.6.3. The Function Related to the Basics Function (Fnc F)

Item Name	Function code	Description, Range and Default value	User setting
Fnc01 Key switch disable	1201	0: Permission, 1: Prohibition 0000 to 1111	
Fnc02 [F] key	1202	0: None 1: Manual print command 2: Hold 3: Alternative switch (Active [F] key) 4: Momentary switch (Active [F] key) 5: Display exchange 6: Tare clear 7: Zero clear 8: Batch start / Pause / Re-start 9: Actual free fall input 10: One shot, Small flow 11: Flow rate monitor (Change rate) 12: mV/V monitor 13: Second digital filter (2nd D.F.)	
Fnc03 Display rewrite rate	1203	1: 20 times/sec. 2: 10 times/sec. 3: 5 times/sec.	
Fnc04 x display	1204	0: None 1: Zero tracking in progress 2: Alarm (Zero range setting error, over) 3: Active [F] key 4: Near-zero 5: HI output (Over the upper limit value) 6: OK output (Between upper and lower limit values) 7: LO output (Below the lower limit value) 8: Large flow 9: Medium flow 10: Small flow 11: Over 12: OK 13: Under 14: Full value 15: Weighing sequence, finished 16: Weighing sequence, in processing 17: Weighing sequence, error 18: Normal batch / Discharge, Identification (ON = Loss in weight) 19 to 24: User input1 to 6 25 to 32: User output 1 to 8	

Item Name	Function code	Description, Range and Default value	User setting
Fnc05 Digital filter	1205	0: None 8:10.0 Hz 1: 100.0 Hz 9: 7.0 Hz 2: 70.0 Hz 10: 5.6 Hz 3: 56.0 Hz 11: 4.0 Hz 4: 40.0 Hz 12: 2.8 Hz 5: 28.0 Hz 13: 2.0 Hz 6: 20.0 Hz 14: 1.4 Hz 7: 14.0 Hz 15: 1.0 Hz	
Fnc06 Second Digital Filter (2nd D.F.)	1206	0: None 8:10.0 Hz 16: 0.7 Hz 1: 100.0 Hz 9: 7.0 Hz 17: 0.56 Hz 2: 70.0 Hz 10: 5.6 Hz 18: 0.40 Hz 3: 56.0 Hz 11: 4.0 Hz 19: 0.28 Hz 4: 40.0 Hz 12: 2.8 Hz 20: 0.20 Hz 5: 28.0 Hz 13: 2.0 Hz 21: 0.14 Hz 6: 20.0 Hz 14: 1.4 Hz 22: 0.10 Hz 7: 14.0 Hz 15: 1.0 Hz 23: 0.07 Hz	
Fnc07 Hold	1207	1: Normal hold 2: Peak hold 3: Averaging hold	
Fnc08 Set value of near-zero	1208	-99999 to 10 to 99999	
Fnc09 Comparison mass at near-zero	1209	1: Gross weight 2: Net weight	
Fnc10 Upper limit value	1210	-99999 to 10 to 99999	
Fnc11 Lower limit value	1211	-99999 to -10 to 99999	
Fnc12 Comparison mass of upper and lower limit	1212	1: Gross weight 2: Net weight	
Fnc13 Full value	1213	-99999 to 99999	

7.6.4. The Function Related to the Hold Function (*HLd F*)

Item Name	Function code	Description, Range and Default value	User setting
HLd01 Averaging time	1301	<input type="text" value="0.00"/> to 9.99	
HLd02 Start wait time	1302	<input type="text" value="0.00"/> to 9.99	
HLd03 Condition of automatic start	1303	<input type="text" value="0"/> : Not used 2: Above the near-zero 1: Above the near-zero, and stable	
HLd04 Release using control input	1304	0: Do not release <input type="text" value="1"/> : Release	
HLd05 Release time	1305	<input type="text" value="0.00"/> to 9.99	
HLd06 Release using fluctuation range	1306	<input type="text" value="0"/> to 99999	
HLd07 Release at the near-zero	1307	<input type="text" value="0"/> : Do not release 1: Release	

7.6.5. The Function Related to the Weighing Sequence Program (59 F)

Item Name	Function code	Description, Range and Default value	User setting
Sq 01 Final value	1401	-99999 to <input type="text" value="0"/> to 99999	
Sq 02 Free fall	1402	-99999 to <input type="text" value="0"/> to 99999	
Sq 03 Preliminary	1403	-99999 to <input type="text" value="0"/> to 99999	
Sq 04 Optional preliminary	1404	-99999 to <input type="text" value="0"/> to 99999	
Sq 05 Over	1405	-99999 to <input type="text" value="0"/> to 99999	
Sq 06 Under	1406	-99999 to <input type="text" value="0"/> to 99999	
Sq 07 Weighing mode	1407	0: No used <input type="text" value="1"/> : Normal batch sequence 2: Discharge sequence 3: Specifying with control input 4: Specifying with CC-Link	
Sq 08 Automatic free fall correction	1408	<input type="text" value="0"/> : No used 1: Moving average of last four times 2: Real time free fall compensation (fixed coefficient) 3: Real time free fall compensation (updated coefficient)	
Sq 09 Automatic free fall band	1409	<input type="text" value="0"/> to 99999	
Sq 10 Active free fall coefficient	1410	-99.999 to <input type="text" value="0.000"/> to 99.999	
Sq 11 Action of over and under	1411	1: Simple comparator <input type="text" value="2"/> : Synchronized to the end of weighing	
Sq 12 Stability at judgment	1412	0: Unnecessary <input type="text" value="1"/> : Necessary	
Sq 13 Tare at start	1413	<input type="text" value="0"/> : Not used 1: Use	
Sq 21 Batch monitoring timer	1421	<input type="text" value="0"/> to 600	
Sq 22 Batch start wait timer	1422	<input type="text" value="0.0"/> to 60.0	
Sq 23 Timer of large flow comparison disable	1423	<input type="text" value="0.0"/> to 60.0	
Sq 24 Timer of medium flow comparison disable	1424	<input type="text" value="0.0"/> to 60.0	
Sq 25 Timer of small flow comparison disable	1425	<input type="text" value="0.0"/> to 60.0	
Sq 26 Judgment wait timer	1426	0.0 to <input type="text" value="0.1"/> to 60.0	

Item Name	Function code	Description, Range and Default value	User setting
Sq 27 Duration time of result	1427	<input type="text" value="0.0"/> to 60.0	
Sq 28 One Shot Timer	1428	<input type="text" value="0.00"/> to 6.00	

7.6.6. The Function Related to the Setpoint (SP F)

Item Name	Function code	Description, Range and Default value	User setting
SP01 Object of SP1	1501	0 to <input type="text" value="1"/> to 11	
SP02 Object of SP2	1502	0: Not used 1: Final value 0 to <input type="text" value="2"/> to 11	
SP03 Object of SP3	1503	2: Optional preliminary 3: Preliminary 0 to <input type="text" value="3"/> to 11	
SP04 Object of SP4	1504	4: Free fall 5: Over 0 to <input type="text" value="4"/> to 11	
SP05 Object of SP5	1505	6: Under 7: Full 0 to <input type="text" value="5"/> to 11	
SP06 Object of SP6	1506	8: Near-zero 9: Free fall coefficient 0 to <input type="text" value="6"/> to 11	
SP07 Object of SP7	1507	10: Upper limit 11: Under limit 0 to <input type="text" value="7"/> to 11	
SP08 Object of SP8	1508	0 to <input type="text" value="8"/> to 11	
SP11 Parameter of SP1	1511	-99999 to <input type="text" value="0"/> to 99999	
SP12 Parameter of SP2	1512	-99999 to <input type="text" value="0"/> to 99999	
SP13 Parameter of SP3	1513	-99999 to <input type="text" value="0"/> to 99999	
SP14 Parameter of SP4	1514	-99999 to <input type="text" value="0"/> to 99999	
SP15 Parameter of SP5	1515	-99999 to <input type="text" value="0"/> to 99999	
SP16 Parameter of SP6	1516	-99999 to <input type="text" value="0"/> to 99999	
SP17 Parameter of SP7	1517	-99999 to <input type="text" value="99999"/>	
SP18 Parameter of SP8	1518	-99999 to <input type="text" value="10"/> to 99999	

7.6.7. The Function Related to the Control I/O (\square F)

Item Name	Function code	Description, Range and Default value	User setting
io 01 Function of IN1	1601	0 : Not used 1 to 6: User output 1 to 6 7 : Zero 8 : Tare	0 to 1 to 24
io 02 Function of IN2	1602	9 : Hold 10 : Gross / Net exchange 11 : Diagnose	0 to 2 to 24
io 03 Function of IN3	1603	12 : Print command 13 : Batch start 14 : Pause 15 : Restart	0 to 3 to 24
io 04 Function of IN4	1604	16 : Emergency stop (Level input) 17 : Error reset 18 : Normal batch/ Discharge exchange (level, ON = Loss in weight)	0 to 4 to 24
io 05 Function of IN5	1605	19 : Actual free fall input 20 : One shot, Small flow 21 : Full open (Level input)	0 to 5 to 24
io 06 Function of IN6	1606	22 : Zero clear 23 : Tare clear 24 : Active F key	0 to 6 to 24
io 11 Function of OUT1	1611	0 : Not used 1 to 8: User output 1 to 8 9 : Stability 10 : Over capacity	0 to 1 to 34
io 12 Function of OUT2	1612	11 : Net display 12 : During tare 13 : Hold 14 : Hold busy	0 to 2 to 34
io 13 Function of OUT3	1613	15 : HI output (Over the upper limit value) 16 : OK output (Between upper and lower limit values) 17 : LO output (Below the lower limit value) 18 : Near-zero	0 to 3 to 34
io 14 Function of OUT4	1614	19 : Full 20 : Over 21 : OK	0 to 4 to 34
io 15 Function of OUT5	1615	22 : Under 23 : Large flow 24 : Medium flow 25 : Small flow	0 to 5 to 34
io 16 Function of OUT6	1616	26 : Normal batch/ Discharge (Identification, ON = Loss in weight) 27 : In weighing sequence	0 to 6 to 34
io 17 Function of OUT7	1617	28 : End of weighing sequence 29 : Error of weighing sequence 30 : In weighing (ON)	0 to 7 to 34
io 18 Function of OUT8	1618	31 : In weighing (1 Hz) 32 : In weighing (50 Hz) 33 : Alarm 34 : Active F key	0 to 8 to 34

Item Name	Function code	Description, Range and Default value	User setting
io 21 OUT1 Logic	1621	1: Inverting output If data is "0" level, the output transistor conducts (ON). 2: Non inverting output If data is "1" level, the output transistor conducts (ON).	
io 22 OUT2 Logic	1622		
io 23 OUT3 Logic	1623		
io 24 OUT4 Logic	1624		
io 25 OUT5 Logic	1625		
io 26 OUT6 Logic	1626		
io 27 OUT7 Logic	1627		
io 28 OUT8 Logic	1628		

7.6.8. The Function Related to the Standard Serial Output (*CL F*)

Item Name	Function code	Description, Range and Default value	User setting
CL 01 Serial data	1701	1: Weighing display 2: Gross 3: Net 4: Tare 5: Gross / Net / Tare	
CL 02 Communication mode	1702	1: Stream 2: Automatic print 3: Manual print	
CL 03 Baud rate	1703	1: 600 bps 2: 2400 bps	

7.6.9. The Function Related to the CC-Link (\overline{CC} F)

Item Name	Function code	Description, Range and Default value	User setting
CC 01 Station number	1801	<input type="checkbox"/> 1 to 64	
CC 02 Number of remote register occupied	1802	0: 1 stations 1: 2 stations <input type="checkbox"/> 2: 4 stations	
CC 03 Baud rate	1803	0: 156 kbps 1: 625 kbps 2: 2.5 Mbps 3: 5 Mbps <input type="checkbox"/> 4: 10 Mbps	
CC 04 Initial process	1804	0: Not needed <input type="checkbox"/> 1: Necessary	
CC 05 Output data	1805	<input type="checkbox"/> 0: Weighing display 1: Net 2: Gross	
CC 06 Weighing information 1	1806	<input type="checkbox"/> 0: Not used 1 : Sequence number 2 : Batch weighing error 3 : Actual free fall 4 : Free fall (Averaging) 5 : Free fall coefficient (Averaging) 6 : Flow rate (In small flow OFF) 7 : Flow rate (Real time)	
CC 07 Weighing information 2	1807	8 : Load cell output. Scale : 1 nV/V 9 : Net (2nd digital filter) 10 : Gross (2nd digital filter)	



A&D Company, Limited

3-23-14 Higashi-Ikebukuro, Toshima-ku, Tokyo 170-0013, JAPAN
Telephone: [81] (3) 5391-6132 Fax: [81] (3) 5391-6148

A&D ENGINEERING, INC.

1756 Automation Parkway, San Jose, California 95131, U.S.A.
Telephone: [1] (408) 263-5333 Fax: [1] (408) 263-0119

A&D INSTRUMENTS LIMITED

Unit 24/26 Blacklands Way, Abingdon Business Park, Abingdon, Oxfordshire OX14 1DY United Kingdom
Telephone: [44] (1235) 550420 Fax: [44] (1235) 550485

A&D AUSTRALASIA PTY LTD

32 Dew Street, Thebarton, South Australia 5031, AUSTRALIA
Telephone: [61] (8) 8301-8100 Fax: [61] (8) 8352-7409

A&D KOREA Limited

한국에이.엔.디(주)
서울특별시 영등포구 국제금융로6길33 (여의도동) 맨하탄빌딩 817 우편 번호 150-749
(817, Manhattan Bldg., 33. Gukjegeumyung-ro 6-gil, Yeongdeungpo-gu, Seoul, 150-749 Korea)
전화: [82] (2) 780-4101 팩스: [82] (2) 782-4280

ООО A&D RUS

ООО "ЭЙ энд ДИ РУС"
121357, Российская Федерация, г.Москва, ул. Верейская, дом 17
(Business-Center "Vereyskaya Plaza-2" 121357, Russian Federation, Moscow, Vereyskaya Street 17)
тел.: [7] (495) 937-33-44 факс: [7] (495) 937-55-66

A&D INSTRUMENTS INDIA PRIVATE LIMITED

509, उद्योग विहार , फेस -5, गुडगांव - 122016, हरियाणा , भारत
(509, Udyog Vihar, Phase-V, Gurgaon - 122 016, Haryana, India)
फोन : 91-124-4715555 फैक्स : 91-124-4715599

ऐ&डी इन्स्ट्रुमेंट्स इण्डिया प्रा० लिमिटेड