

AD-4530

Digital Indicator





INSTRUCTION MANUAL



1WMPD4002282

WARNING DEFINITIONS

The warnings described in this manual have the following meanings:

 WARNING	A potentially hazardous situation which, if not avoided, could result in death or serious injury.
 CAUTION	A potentially hazardous situation which, if not avoided, may result in minor or moderate injury or damage to the instrument.
	This symbol indicates caution against electrical shock. Do not touch the part where the symbol is placed.
	This symbol indicates the ground terminal.
	This symbol indicates information useful to the user for operation of the device.

© 2011 A&D Company Ltd. All rights reserved.

No part of this publication may be reproduced, transmitted, transcribed, or translated into any language in any form by any means without the written permission of A&D Company Ltd.

The contents of this manual and the specifications of the instrument covered by this manual are subject to change for improvement without notice.

CONTENTS

1. INTRODUCTION	3
1.1. Features	3
2. BEFORE USE	4
2.1. Precautions Before Use	4
2.2. Precautions During Use	4
3. SPECIFICATIONS	6
3.1. General specifications	6
3.2. Functions	7
3.3. Options	8
4. FRONT PANEL	10
4.1. Display	10
4.2. Status indicators	10
4.3. Keys	11
4.4. Operation mode	11
5. REAR PANEL	12
5.1. Connector function	12
5.2. Equivalent circuit figure of control input section	14
5.3. Attaching the connector	15
6. COMPONENTS AND FUNCTIONS	16
6.1. Flowchart	16
6.2. Descriptions of functions	17
7. CALIBRATION	18
7.1. Calibration Modes	18
7.2. Calibration Errors	20
8. FUNCTION MODE	21
8.1. Structure of Functions	21
8.2. Key operation	21
8.3. Function Items	23
9. DIGITAL ZERO (DZ)	28
9.1. Operating by key	28
9.2. Operating by I/O input	28
9.3. Zero tracking	28
9.4. Power On Zero	29
9.5. Backup of DZ	29
10. HOLD FUNCTION	30
10.1. Basic function	30
10.2. Hold indicator	30

10.3.	Priority of when inputting hold	30
10.4.	Over value during hold	30
10.5.	Hold Modes	31
11.	LATCH	33
12.	COMPARATOR FUNCTION	34
12.1.	Detailed description of the comparator mode	34
12.2.	Setting the upper and lower limit value	34
12.3.	Example of the comparator mode	35
12.4.	Hysteresis	35
13.	ANALOG OUTPUT	39
13.1.	Analog voltage DAV (0V to 10V)	39
13.2.	Analog current DAI (4mA to 20mA)	39
14.	SERIAL INPUT AND OUTPUT	40
14.1.	Data output format	40
14.2.	Command or response	40
15.	MAINTENANCE	42
15.1.	Error display	42
15.2.	Checking each operation	43
16.	SETTING LIST	48
16.1.	Calibration (C function)	48
16.2.	Basic Functions	49
16.3.	Comparator	49
16.4.	Analog	50
16.5.	Serial Communication	50
17.	EXTERNAL DIMENSIONS	51

1. INTRODUCTION

Thank you for purchasing the AD-4530 Digital Indicator.

This manual describes how the AD-4530 works and how to get the most out of it in terms of performance. Please read this manual completely before using the AD-4530.

1.1. Features

The AD-4530 has the following features.

- Calibration without actual load (Digital span mode)
Keying in the sensor's rated output voltage (mV/V) allows calibration to be performed without using an actual load.
- Digital filter
The range for selecting the cutoff frequency is none (no function) or 0.1Hz to 2.5Hz.
- Digital zero (DZ, zero adjustment)
The digital zero function sets a desired measurement point as zero and displays the deviation from this zero point. When measuring a load, it can be used as the tare, etc. The zero value is maintained in non-volatile memory (EEPROM). Therefore, when turning the power off then on (or power loss), this zero value is still available. Memory backup of 10,000,000 or more times is available.
- Zero tracking function
The zero tracking function is used to set the corrected zero automatically by sensing the zero point drift.
- Hold function
Sample, peak, bottom and bipolar peak values can be held using the hold mode.
- Comparison function
Comparison results (HI, OK and LO) are output as display data and also as contact signals.
Chattering of the output can be prevented by setting the hysteresis.
- Various data output terminals
Available options are comparator output, serial interface (RS-232C/RS-485), analog voltage output (DAV) and analog current output (DAI).

2. BEFORE USE

The digital indicator is a precision instrument. Unpack the digital indicator carefully and confirm that all items are present.

2.1. Precautions Before Use

- Avoid water and moisture.
- Avoid vibration, shock, extremely high temperature and humidity, direct sunlight, dust, and air containing salt or sulfurous gases.
- Avoid places where inflammable gases or vapors are present.
- The operating temperature is -10°C to $+40^{\circ}\text{C}$.
- A 100 VAC to 240 VAC power source is required. Use a stable power supply free from sudden dropout or noise as they can cause malfunctions. Avoid sharing the power line.
- Keep cables away from power cables and other sources of electrical noise.
- Connect only a non-inductive load of $10\text{ k}\Omega$ or more to the analog voltage output terminals.
- Connect only a non-inductive load of $510\ \Omega$ or less to the analog current output terminals.
- When connecting long cables to the sensors, keep the cables away from power cables and other sources of electrical noise.
- Do not connect the AD-4530 to the power supply before installation is completed. The AD-4530 has no switch to disconnect the power supply.
- Use shielded load cell cables.
- Do not connect too many sensors. Otherwise, instrument damage may occur.

2.2. Precautions During Use

- The AD-4530 is a precision instrument that measures the microvolt output from sensors. Prevent noise sources such as power lines, radios, electric welders or motors from affecting the instrument.
- Do not try to modify the AD-4530.
- In all hold modes, the hold data is saved digitally, so there is no drooping of the value displayed on the display panel or the analog output. Note that the hold function is disabled when the AD-4530 is disconnected from the power supply.

 WARNING

Disconnect from the power supply before removing the cover.

- When removing the cover, make sure that the power is off.



Do not touch the instrument immediately after it is disconnected from the power supply.

- To avoid electrical shock, do not touch the internal part of the instrument within ten seconds after switching the power off.

 CAUTION

Be sure to fasten all the screws completely.

- Loose screws may come off during operation and a short circuit may occur or measurement errors may occur due to noise.

3. SPECIFICATIONS

3.1. General specifications

- Number of measurement points 1
- Sensor type Strain gauge sensors (Output resistance: 10k Ω or less)
- Voltage requirement 100 VAC to 240 VAC +10%, -15% (50/60 Hz)
- Power requirement Approx. 10 VA
- Sensor power supply DC5V \pm 5%, 50 mA
120 Ω sensor: Up to one sensor can be connected.
350 Ω sensor: Up to three sensors can be connected.
- Measurement ranges Signal input range: -35 to +35 mV (-7 to +7 mV/V)
Zero adjustment range: -35 to +35 mV (-7 to +7 mV/V)
Minimum guaranteed input sensitivity: 0.4 μ V/d or more (d = minimum division)
Minimum displayed input sensitivity: Non-limit
- A/D conversion method Delta sigma method
- Internal division Approx. 1,000,000 counts
- Sampling rate 10 times / second
- Display range -9999 to +9999
- Linearity Within 0.01%F.S. \pm 1 digit
- Temperature characteristics Zero: \pm 0.2 μ V/ $^{\circ}$ C typ.
Span: \pm 30 ppm/ $^{\circ}$ C typ.
- Operating temperature -10 $^{\circ}$ C to +40 $^{\circ}$ C
- Operating humidity Max. 85% RH (no condensation)
- Calibration method Digital span: Method not using an actual load
Actual load calibration
- External dimensions 96 x 48 x 127.5 mm (W x H x D)
Panel cutout: 92 x 45 mm
Separation: Width: 120 mm or more
Length: 70 mm or more
- Weight Approx. 290 g
- Display panel Measurement value display:
7-segment, 4-digit red LED screen with 14-mm character size
Polarity display: 1 red LED screen
Status displays:
1 red LED screen, 2 green LED screens, 2 orange LED screens
Key switch: 5 switches

3.2. Functions

- Digital zero (Zero adjustment)
 - Sets the measurement value to zero using the ZERO key, external input or the command signal.
 - The digital zero is maintained in non-volatile memory (EEPROM).
 - Available setting range
 - The available setting range is 1 to 100% of the rated capacity.
- Zero tracking function
 - Automatically performs the zero point update by sensing the zero point movement.
 - Available setting range
 - Tracking time :0.0 to 5.0 (second)
 - Tracking width :0.0 to 9.9 (d)
- Power on zero function
 - Sets the digital zero state at power on.
- Digital filter function
 - Cutoff frequency range: 0.1 to 2.5 (Hz)
- Comparator function
 - HI, OK or LO is determined by the setting of the upper or lower limit value.
- Hold function
 - Select from sample hold, peak hold, bottom hold, or bipolar peak hold.
- Latch function
 - Perform latching of the display value, comparator output, analog output, serial output, using the external LATCH input.
- Relay output function
 - Provides contact output of the HI, OK or LO signals.
- Serial input and output function
 - The RS-485/RS-232C option can output measurement values and input commands.
- Analog output function
 - Outputs the measurement value as an analog voltage or current.

3.3. Options

3.3.1. Options

AD-4530-200:	Relay output
AD-4530-030:	RS-485
AD-4530-040:	RS-232C
AD-4530-007:	Analog output
AD-4530-237:	Relay output, RS-485, Analog output
AD-4530-247:	Relay output, RS-232C, Analog output

Note: Only one option can be installed in the AD-4530 at a time.

3.3.2. Option specifications

- Relay output HI, OK, LO
 (AD4530-200) AC250V or DC30V 3A (Total current 5A)
 (AD4530-237) Contact construction: Metallic contact
 (AD4530-247) Contact capability: 1a
 Mechanical operating life: 5,000,000 times or more
 Electrical operating life: 100,000 times or more (Resistive load)
 Connector: 4 pin (HI, OK, LO, COM)

- RS-485 EIA RS-485 conformity
 (AD4530-030) Number of drops: Up to 31
 (AD4530-237) Connector: 5 pin (A, B, SG, A, B)

- RS-232C EIA RS-232C conformity
 (AD4530-040) Connector: 5 pin (RxD, TxD, SG, IC, IC)
 (AD4530-247)

- Analog output D/A conversion method: PWM
 (AD4530-007) Resolution: 13 bit equivalent
 (AD4530-237) Response rate: Approx. 500 ms
 (AD4530-247) Voltage output: 0-10V Adaptive load: 10 kΩ min.
 Current output: 4-20 mA Adaptive load: 510 Ω max.
 Non-linearity: ±0.1% typ.
 Temperature coefficient: Zero point 100 ppm/°C typ.
 Connector: 3-pin (VOUT, IOUT, COM)

3.3.3. Installing an option

1. Remove the two screws that secure the guide rail, and then remove the guide rail.
2. Remove the two screws that secure the case.
3. Pull the case out from the front panel (holding it as shown).
4. Remove unnecessary blank panels with nippers, etc.
5. Insert the option board at the position specified on the rear of the front panel.
6. Reattach the case and guide rail by reversing the steps above.

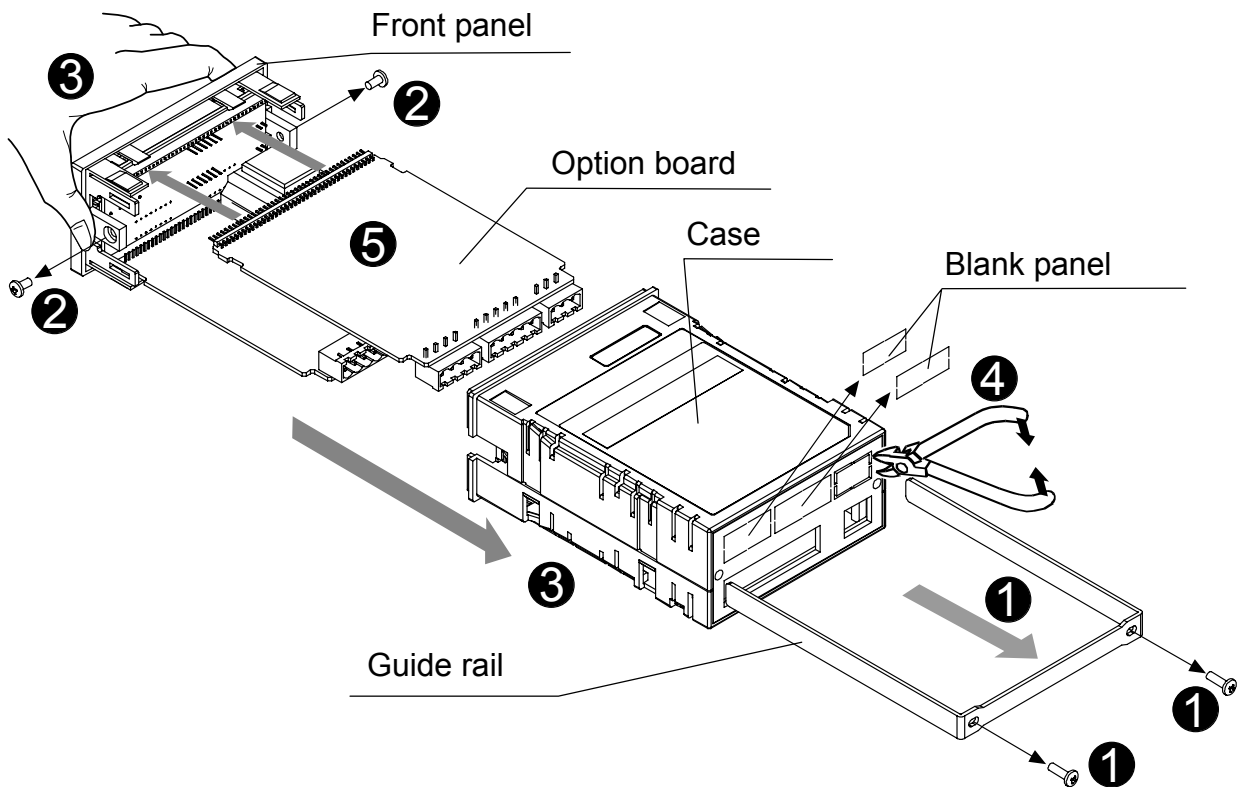

4. FRONT PANEL

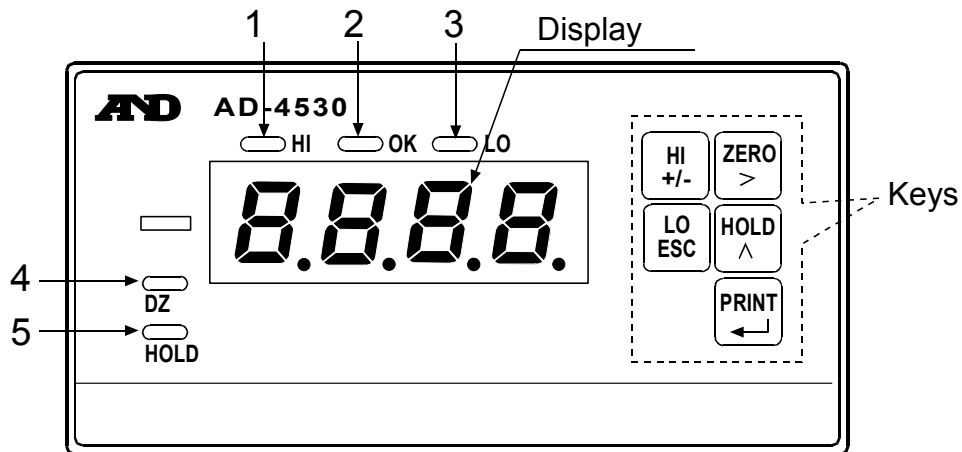







4.1. Display

Displays a measured or set value. To set the decimal point position, use function mode (CF01). The display is composed of four seven-segment indicators plus a minus sign.

4.2. Status indicators

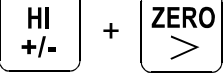
	Name	Description
1	HI	Turns on when the measured value is greater than the upper limit (HI).
2	OK	Turns on when the measured value is equal to or greater than the lower limit and equal to or less than the upper limit.
3	LO	Turns on when the measured value is less than the lower limit (LO).
4	DZ	Turns on when adjusting the digital zero.
5	HOLD	Turns on when a value is being held.

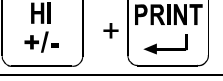

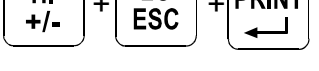
4.3. Keys

Operation	Function
	Press to proceed to the upper limit value setting mode. When inputting a numerical value, press to change the polarity.
	Press to proceed to the lower limit value setting mode. When inputting a numerical value, press to cancel the setting.
	Press to turn the digital zero on. When inputting a numerical value, press to shift the position of the blinking digit to the right or change the function group.
	Press to turn the digital zero off.
	Press to turn holding on or off. When inputting a numerical value, press to change the blinking digit or change the function parameter.
	Press to output the serial data (print). When inputting a numerical value, press to enter the setting.
	Press to proceed to the calibration mode.
	Press to proceed to the function selection mode.
	Press to proceed to the selection mode in the check mode.

* The digital zero function sets a desired measurement point as zero and displays the deviation from this zero point. When measuring a load, it can be used as the tare, etc.

* The zero value is maintained in non-volatile memory (EEPROM). This zero value is retained even after the power has been turned off and on (or power is lost).

* To change the digital zero operation, use the function (CF11) .

To protect against accidental operation, press the  and  key to turn the digital zero on or off.

4.4. Operation mode

- Upper / lower limit setting mode
Use this mode to set the upper and lower limit of the comparator.
- Calibration mode
Use this mode to perform zero and span calibration with an actual load.
- Function setting mode
Use this mode for setting functions.
- Check mode
Use this mode to confirm input and output operation.

5. REAR PANEL

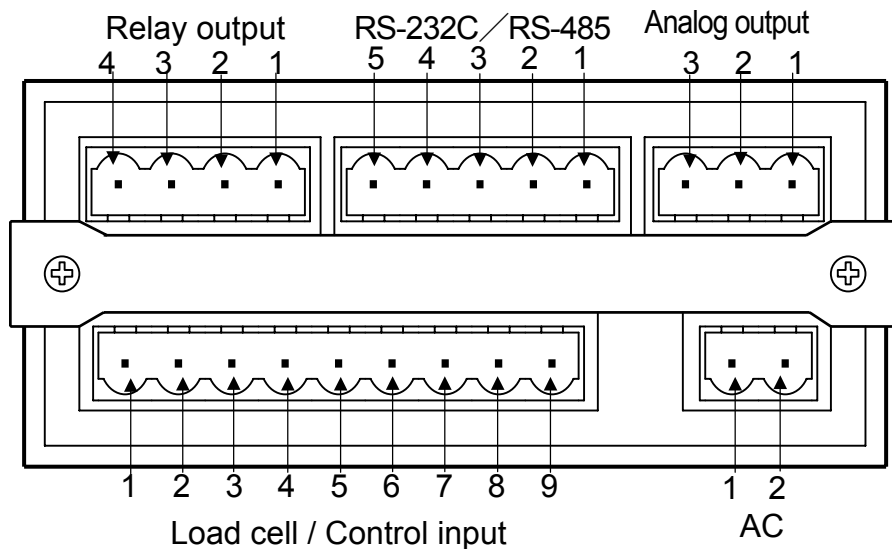

⚠ CAUTION

Confirm the terminal numbers when making connections.

- When making connections, confirm the terminal numbers printed on the side of the terminal block and on the top of the indicator casing.

5.1. Connector function

5.1.1 AC input connector

- (1) AC Connect the AC power cord.
- (2) AC The power requirement is 100 VAC to 240 VAC, 50/60 Hz.

⚠ CAUTION

When making connections,

- Switch off the power of all the instruments used.
- Keep cables away from power cables and other sources of electrical noise.

5.1.2 Load cell / Control input connector

Load cell

- (1) SHLD Connect the shielded cable of the sensor cable.
- (2) SIG- Negative signal input terminal for the sensors.
- (3) SIG+ Positive signal input terminal for the sensors.
- (4) EXC- Negative excitation terminal for the sensors.
- (5) EXC+ Positive excitation terminal for the sensors.

Control input

- (6) COM Input COMMON terminal.
- (7) LATCH Inputs the latching signal for the function settings and outputs.
- (8) HOLD Inputs the hold signal.
- (9) ZERO Inputs the zero correction signal.

5.1.3 Relay output connector (Option)

- (1) COM Relay output COMMON terminal
- (2) LO Relay LO output terminal
Outputs LO when the measured value is less than the lower limit.
- (3) OK Relay OK output terminal
Outputs OK when the measured value is equal to or greater than the lower limit and equal to or less than the upper limit.
- (4) HI Relay HI output terminal
Outputs HI when the measured value is greater than the upper limit.

 CAUTION

Comparator output

- | |
|--|
| <ul style="list-style-type: none">■ To prevent damage, do not exceed the rated capacities of the output relays. To protect the output relays, use a varistor, CR circuits or diodes. |
|--|

5.1.4 Serial communication connector (Option)

In the case of RS-232C:

- (1) IC Connected internally (Do not use)
- (2) IC Connected internally (Do not use)
- (3) SG Signal ground terminal
- (4) TxD B terminal
- (5) RxD A terminal

In the case of RS-485 (Two wire connection):

- (1) B B terminal
- (2) A A terminal
- (3) SG Signal ground terminal
- (4) B B terminal
- (5) A A terminal

* Each of the A and B connections has two terminals.

These terminals are connected internally and can be used for a terminating resistor or multi-drop connection.

5.1.5 Analog output connector (Option)

- (1) COM COMMON terminal of the analog output
- (2) IOOUT Analog current output terminal
- (3) VOUT Analog voltage output terminal

5.2. Equivalent circuit figure of control input section

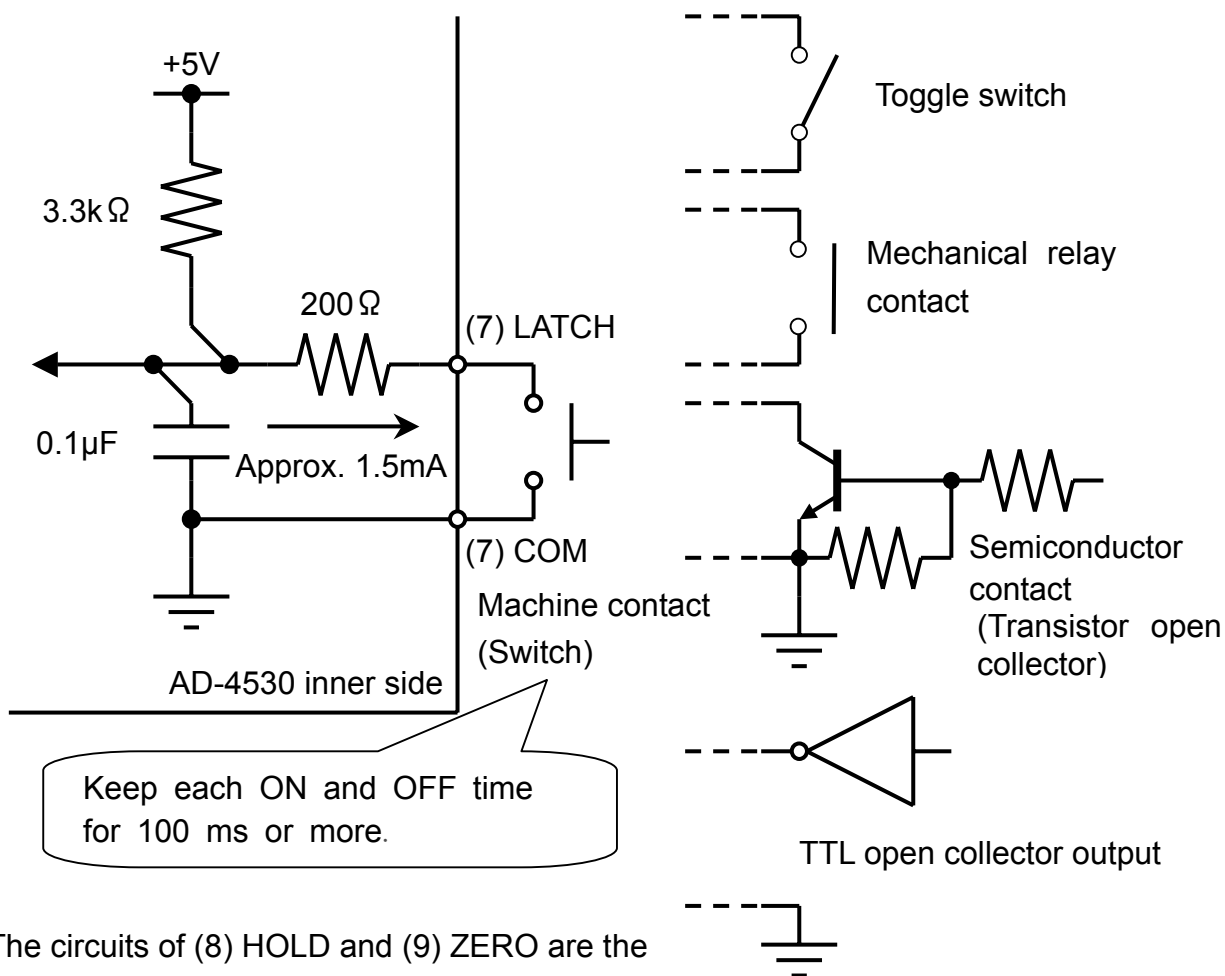

CAUTION

When connecting the input terminal:

- Select a switching element of the non-voltage input type, such as a mechanical contact or semiconductor switch.
- Use the leakage of the switching element, when OFF, of 30 μ A or less.

5.3. Attaching the connector

Wire size	12 to 24 (AWG)
Stripping length	6 to 7 mm
Tightening torque	0.5 to 0.6 Nm

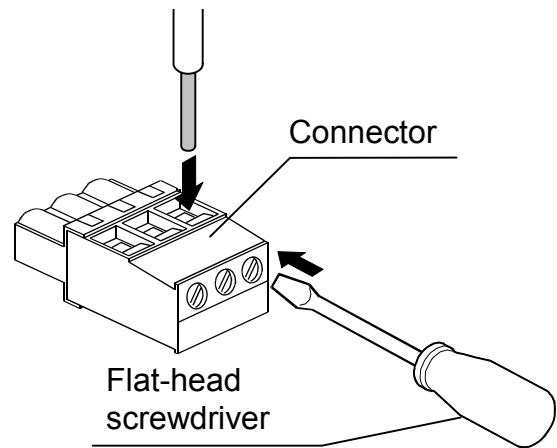

6. COMPONENTS AND FUNCTIONS

The following flowchart shows how the functions of the AD-4530 are executed.

6.1. Flowchart

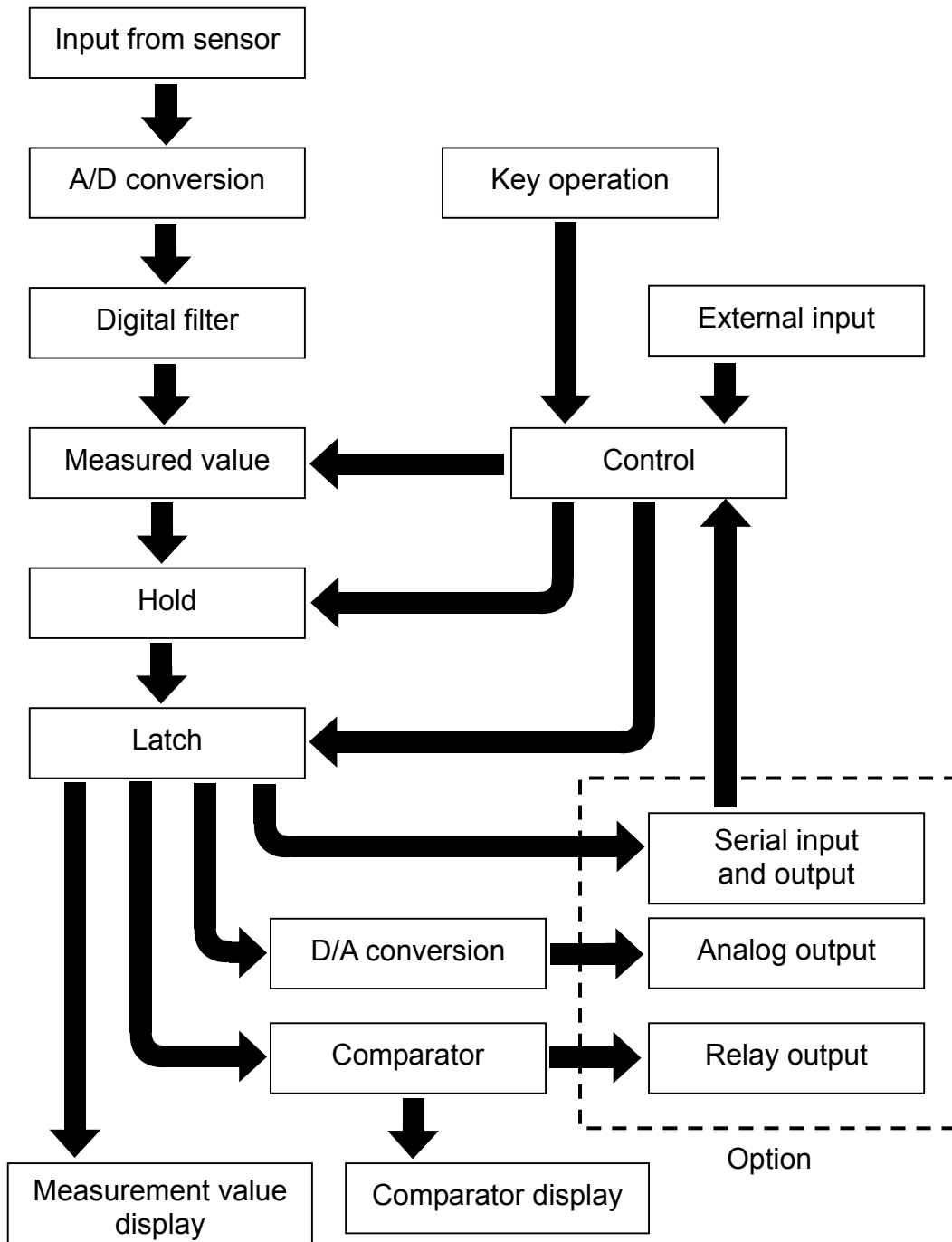

6.2. Descriptions of functions

6.2.1. Digital filter

The selection range of the cutoff frequency is 2.5 Hz to 0.1 Hz or none.

6.2.2. Digital zero

The digital zero function sets a desired measurement point as zero and displays the deviation from this zero point.

6.2.3. Hold function

The AD-4530 has four hold modes: sample hold, peak hold, bottom hold and bipolar peak hold. Select a hold mode in function mode (F003).

6.2.4. Latch function

The AD-4530 can latch the value or output, set by the function (F004), by the ON/OFF timing of the external LATCH input.

The latch operation occurs after processing of the hold operation.

6.2.5. Comparator function

The comparator function compares the measured value against set values, displays the comparison with LEDs, and outputs the comparison results (HI, OK or LO) from the rear panel relay output terminals.

6.2.6. Relay output (Option)

The results of the comparator operation can be output by the relay output terminal.

6.2.7. Analog output (Option)

The analog output outputs data by converting the measurement value to an analog voltage DAV (0V to 10V) or analog current DAI (4mA to 20mA). (F201 to F204)

6.2.8. Serial input and output (Option)

By using the RS-232C or RS-485, outputting the measurement value, receiving commands and setting functions are available.

7. CALIBRATION

The AD-4530 measures voltage signals from sensors and displays the values. Calibration is performed so that the AD-4530 performs correctly.

The decimal point (CF01), minimum scale value (CF02) and rated capacity (CF03) are set using function mode.

The zero point input voltage (CF04), the span input voltage (CF05) and the display value for the span input voltage (CF06) are set using calibration mode.

Calibration setting by function mode is also available. (Digital calibration)

- * During calibration, maintain a stable environment to prevent calibration errors.
- * You can confirm stabilization by confirming that the HOLD LED is on.
- * The decimal point blinks to indicate that a number is being displayed, not a weighing value.

7.1. Calibration Modes

In weighing mode, press the  and  key to enter calibration mode.

 Enter zero point calibration mode.

 Return to weighing mode.

7.1.1. Zero point calibration mode

With nothing on the load cell, wait for it to stabilize, and then press the  key.

 Perform zero point calibration, and proceed to span calibration mode.

 Cancel zero point calibration, and proceed to span calibration mode.

 Hold to display the mV/V of the zero point.

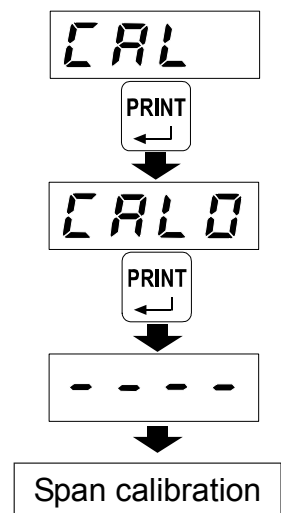

7.2. Calibration Errors

Display	Cause	Remedy
<i>C E2</i>	Voltage at zero point calibration was too far in the positive direction.	Confirm the rating and connection of the load cell.
<i>C E3</i>	Voltage at zero point calibration was too far in the negative direction.	
<i>C E4</i>	The mass value exceeds the weighing capacity.	Use a proper mass.
<i>C E5</i>	The mass value is less than the minimum scale value.	Use a proper mass.
<i>C E6</i>	The load cell sensitivity is insufficient.	Confirm the load cell connection. Use a proper mass.
<i>C E7</i>	Voltage at span calibration is less than the zero point.	Confirm the load cell connection.
<i>C E8</i>	When adding a load of the weighing capacity, the load cell output voltage is too high.	Use a load cell with a greater weighing capacity or set a smaller weighing capacity value.

8. FUNCTION MODE

Use the function mode to set various functions and data. The set values are saved in non-volatile memory and are maintained even if the power is switched off.

8.1. Structure of Functions

The first 2 characters of the Function No. are the function group. The last 2 characters of the Function No. are the function item.

CF Calibration function

F0 Basic function

F1 Comparator function

Use this function to set the comparator operation.

F2 Analog output function

Use this function to set the output value of the analog voltage output and analog current output.

F3,F4 Serial communication function

Use this function to set the RS-232C and RS-485.

* Set the zero point input voltage (CF04), the span input voltage (CF05) and the display value for the span input voltage (CF06) in calibration mode.

* Set the upper limit value (F101) and lower limit value (F102) in comparator mode.

* When setting a function, the decimal point blinks to indicate that a number is being displayed, not a weighing value.

8.2. Key operation

In weighing mode, press the  and  keys to enter function selection mode.

8.2.1. Function selection mode

 Select the function group. (First 2 characters)

 Select the function item. (Last 2 characters)

 Enter setting changing mode.

 Save the setting in non-volatile memory, and then return to weighing mode.

8.2.2. Setting changing mode (Two methods)

P Parameter selection method (All digits blinking)

 Change the parameter.

 Enter the setting and return to function selection mode.

 Cancel the setting and return to function selection mode.

D Digital input method (Change the blinking digit only)

 Move the digit to be changed to the right.

 Change the value of the blinking digit.





 Change the polarity.

 Enter the setting and return to function selection mode.

 Cancel the setting and return to function selection mode.

8.3. Function Items

8.3.1. Calibration (C function)

Function No. Setting range	Function	Description	Default value Setting type
<i>CF01</i> 0 to 3	Decimal point position	Decimal point position of the weighing value: <i>0:0000</i> <i>1:0000</i> <i>2:0000</i> <i>3:0000</i>	<i>0</i> P
<i>CF02</i> 1 to 50	Minimum scale value	Minimum division (d) of the weighing value. <i>1:1</i> <i>10:10</i> <i>2:2</i> <i>20:20</i> <i>5:5</i> <i>50:50</i>	<i>1</i> P
<i>CF03</i> 1 to 9999	Maximum weighing capacity	Weighing is possible up to the value of this setting plus 8 d (8 minimum divisions). Decimal point position depends on <i>CF01</i> .	<i>7000</i> D
<i>CF04</i> -7.000 to 7.000	Input voltage of zero point	Input voltage from the load cell at zero point. (Unit: mV/V)	<i>0.000</i> D
<i>CF05</i> 0.001 to 9.999	Input voltage of span	Input voltage from the load cell at span (measurement point - zero point). (Unit: mV/V)	<i>7.000</i> D
<i>CF06</i> -9999 to 9999	Display value for input voltage of span	Display value for span (measurement point - zero point). Decimal point position depends on <i>CF01</i> .	<i>7000</i> D
<i>CF07</i> 0 to 100	Zero adjustment range	Range to enable zero adjustment by the digital zero. Expressed in percent of the rated capacity with the calibration zero point as the center.	<i>100</i> D
<i>CF08</i> 0.0 to 5.0	Zero tracking time	Performed in combination with zero tracking width. (Unit: second) When <i>0.0</i> , zero tracking is not performed.	<i>0.0</i> D
<i>CF09</i> 0.0 to 9.9	Zero tracking width	Performed in combination with zero tracking time. (Unit: 0.1 d) When <i>0.0</i> , zero tracking is not performed.	<i>0.0</i> D
<i>CF10</i> 0 to 2	Power on zero	Digital zero when turning power on: <i>0</i> : Digital zero off <i>1</i> : Perform digital zero again <i>2</i> : Use state when the power was turned off	<i>0</i> P
<i>CF11</i> 1 to 2	Zero operation	<i>1</i> : On with  , off with  +  <i>2</i> : On or off with  + 	<i>1</i> P

8.3.2. Basic Function

Function No. Setting range	Function	Description	Default value Setting type
F001 0000 to 1111	Disable key	Each digit of the setting corresponds to a key switch. Only available in weighing mode. Key assignment: 0 : Enabled 1 : Disabled 	0000 (Binary) 0
F002 0 to 11	Digital filter	Cutoff frequency: 0 : Off 6 :0.5Hz 1 :2.5 Hz 7 :0.35 Hz 2 :2.0 Hz 8 :0.25 Hz 3 :1.5 Hz 9 :0.20 Hz 4 :1.0 Hz 10 :0.15 Hz 5 :0.7 Hz 11 :0.10 Hz	4 P
F003 0 to 4	Hold mode	0 : Off 1 : Sample hold 2 : Peak hold 3 : Bottom hold 4 : Bipolar peak hold	1 P
F004 0000 to 1111	LATCH function	Function corresponds to an external input latch. Setting and latch Assignment: 0 : Off 1 : On 	0000 (Binary) 0

*If you want to confirm the weighing value when setting the digital filter (F002), press the

key.

When the weighing value is displayed, the LED blinks and the display can be set to zero by pressing the key.

Press the key to return the setting display.

8.3.3. Comparator

Function No. Setting range	Function	Description	Default value Setting type
F 101 -9999 to 9999	Upper limit value	Upper limit value of comparator. Decimal point position depends on <i>CFD 1</i> .	0000 D
F 102 -9999 to 9999	Lower limit value	Lower limit value of comparator. Decimal point position depends on <i>CFD 1</i> .	0000 D
F 103 0 to 2	Comparator mode	0 :Off 1 :On when the measured value is not near zero 2 : Always on	2 P
F 104 -9999 to 9999	Near zero	Set the near zero range for comparator mode.	0000 D
F 105 1 to 3	Hysteresis mode	Hysteresis direction: 1 :Upward 2-level judgment 2 :Upper / lower limit judgment 3 :Downward 2-level judgment	2 P
F 106 0.0 to 5.0	Hysteresis time	Set the hysteresis time by units of 0.1 seconds. When 0.0 , the hysteresis is not used.	0.0 D
F 107 00 to 99	Hysteresis width	Set the hysteresis width to a two-digit value. When 00 , the hysteresis is not used.	99 D

8.3.4. Analog

Function No. Setting range	Function	Description	Default value Setting type
F201 -9999 to 9999	0 V output	Measurement value at DAV 0V output. Decimal point position depends on <i>CFD 1</i> .	0000 D
F202 -9999 to 9999	10 V output	Measurement value at DAV 10V output. Decimal point position depends on <i>CFD 1</i> .	1000 D
F203 -9999 to 9999	4 mA output	Measurement value at DAI 4 mA output. Decimal point position depends on <i>CFD 1</i> .	0000 D
F204 -9999 to 9999	20 mA output	Measurement value at DAI 20 mA output. Decimal point position depends on <i>CFD 1</i> .	1000 D

8.3.5. Serial Communication

Function No. Setting range	Function	Description	Default value Setting type
<i>F301</i> 2.4 to 38.4	Baud rate	<i>2.4</i> :2400 bps <i>4.8</i> :4800 bps <i>9.6</i> :9600 bps <i>19.2</i> :19200 bps <i>38.4</i> :38400 bps	<i>2.4</i> P
<i>F302</i> 7 to 8	Data bit length	<i>7</i> :7 bits <i>8</i> :8 bits	<i>7</i> P
<i>F303</i> 0 to 2	Parity	<i>0</i> :None <i>1</i> : Odd <i>2</i> : Even	<i>2</i> P
<i>F304</i> 1 to 2	Stop bit	<i>1</i> :1 bit <i>2</i> :2 bits	<i>1</i> P
<i>F305</i> 1 to 2	Terminator	<i>1</i> :CRLF <i>2</i> :CR	<i>1</i> P
<i>F306</i> 1 to 2	Communication mode	<i>1</i> : Stream <i>2</i> : Manual print	<i>2</i> P
<i>F307</i> 00 to 99	Model No.	ID that is added to the serial output. When setting is <i>00</i> , the ID is not added.	<i>00</i> D
<i>F401</i> <i>F402</i> <i>F403</i> <i>F404</i> <i>F405</i> 00 to 7F	Unit character1 Unit character2 Unit character3 Unit character4 Unit character5	Unit character added to serial output. Set with the hexadecimal ASCII code. All characters after <i>00</i> are ignored.	<i>00</i> <i>00</i> <i>00</i> <i>00</i> <i>00</i> (Hexadecimal) D

8.3.6. Error

Display	Cause	Remedy
<i>Ad E</i>	The data can not be acquired from A/D converter.	Repair is required.
<i>EEPE</i>	Correct data cannot be read from EEPROM.	Perform initialization. If the initialization does not clear the error, repair is required.
<i>CALE</i>	Calibration data error.	Perform calibration.
<i>C E*</i>	Calibration error.	Refer to "7.2.Calibration Errors".
<i>dt E</i>	A setting value is out of range.	Check setting values and correct if necessary.

8.3.7. ASCII code (20h~7Fh)

Hexadecimal	00	01	02	03	04	05	06	07	08	09	0A	0B	0C	0D	0E	0F
20	SP	!	"	#	\$	%	&	'	()	*	+	,	-	.	/
30	0	1	2	3	4	5	6	7	8	9	:	;	<	=	>	?
40	@	A	B	C	D	E	F	G	H	I	J	K	L	M	N	O
50	P	Q	R	S	T	U	V	W	X	Y	Z	[\]	^	_
60	`	a	b	c	d	e	f	g	h	i	j	k	l	m	n	o
70	p	q	r	s	t	u	v	w	x	y	z	{	 	}	~	DL



20 SP is space 7F DL is DEL

9. DIGITAL ZERO (DZ)



The digital zero function sets a desired measurement point as zero and displays the deviation from this zero point. When measuring a load, it can be used as the tare, etc. While using this function, the DZ LED turns on.

9.1. Operating by key

When the  key is pressed, the display is set to zero, and the DZ function is turned on.

If you want to turn the DZ function off, press the  +  keys.

* The operating procedure depends on the setting of (CF11).

When the  +  keys are pressed, the DZ function is turned on or off.

When it is turned on, the display is set to zero.

9.2. Operating by I/O input

Whether the DZ function is ON or OFF depends on the operation of the zero terminal of the I/O input.

When the zero terminal is on (connected to the Com terminal), the DZ function is turned on and the display is set to zero.

9.3. Zero tracking

Using the zero tracking function, the AD-4530 updates the zero point automatically by sensing the zero point movement.

Zero tracking functions only when digital zero is turned on. Set the zero tracking time (CF08) and zero tracking width (CF09) by setting the function.

* When the zero point is over the zero correction range, zero tracking is not performed.

* When refreshing the zero point using the zero tracking function, backup to non-volatile memory will not be performed.

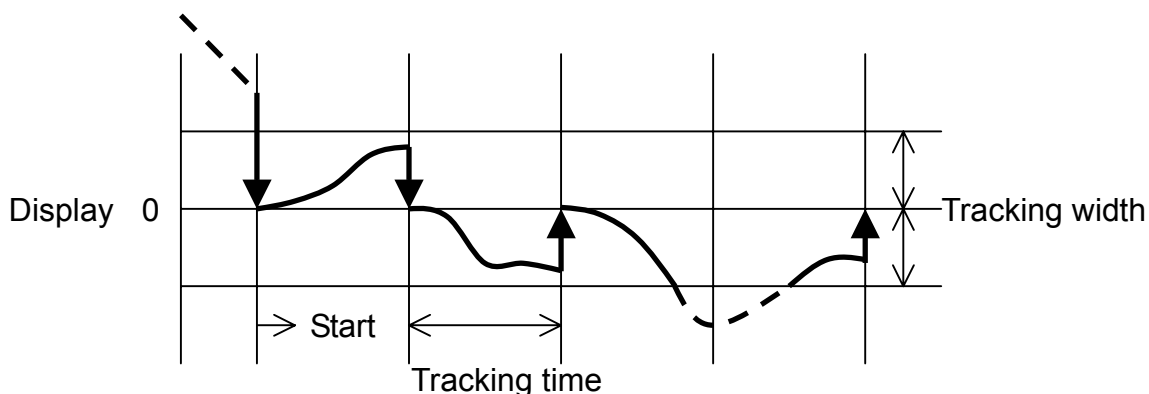

9.4. Power On Zero

Select the digital zero for when the power is turned on. (CF10)

0: Digital zero off

Measurement is based on the zero point of the calibration.

Use with the measurement of an absolute value such as force measurement.

1: Perform digital zero again

Measurement is based on the zero point when the power is turned on.

Use with weight measurement etc.

2: Use the state when the power was turned off

Measurement is based on the DZ.

Use with measurements that require a long time such as a hopper scale.

It is a useful function in case of a power loss.

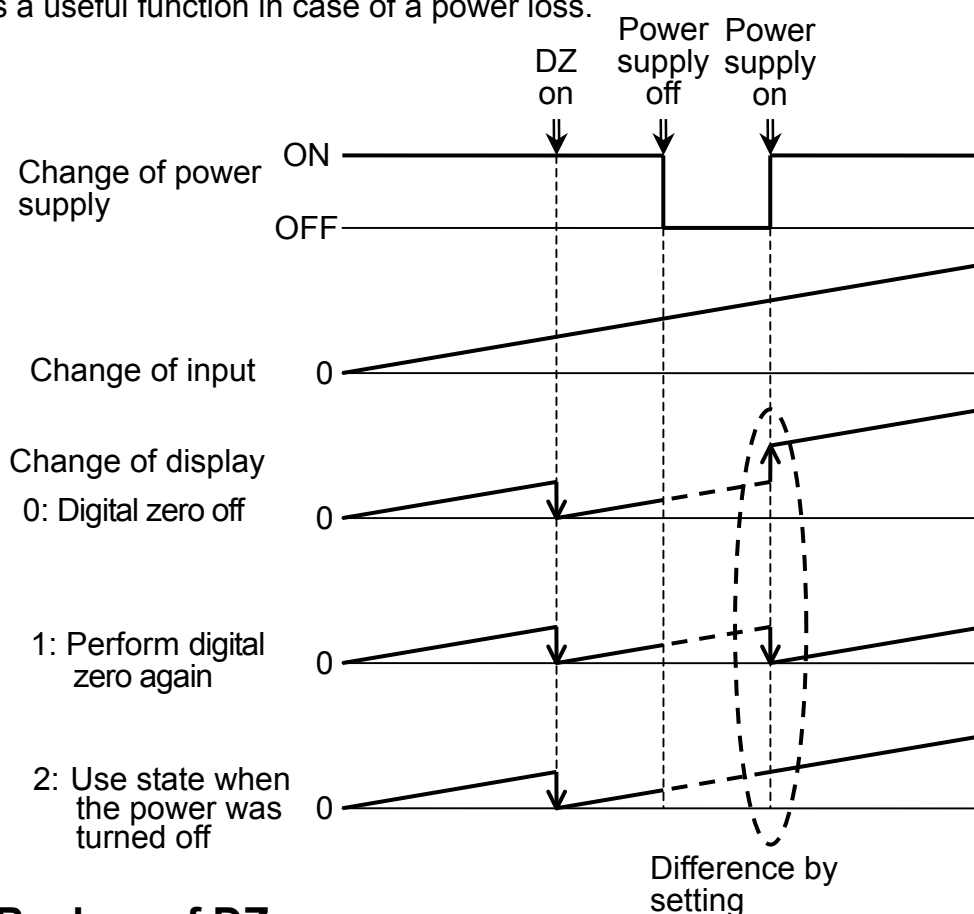

9.5. Backup of DZ

The DZ value is maintained in non-volatile memory (EEPROM).

Writing up to 10,000,000 times is available, so keep track of use frequency.

If the available DZ memory is 10% or less, the LED of the digital zero (DZ) blinks.

With the setting (CF10=2), the backup memory is refreshed only when refreshed by key operation or command.

(When refreshing the zero point using the zero tracking function, the backup memory is not refreshed.)

10. HOLD FUNCTION

The AD-4530 has four hold modes: sample hold, peak hold, bottom hold and bipolar peak hold. A hold mode can be selected in function mode (F003).

10.1. Basic function

Start the hold function by pressing the  key, setting the hold terminal of the external input to on, or a serial communication command.

10.1.1. Operation by using the key

Press the  key. The hold function starts and the AD-4530 holds the displayed value.

While the display is in hold mode, pressing the  key again cancels the hold function, and the AD-4530 displays the weight value.

10.1.2. Operation using the external input hold terminal

When the external hold input terminal is turned on (contact input), the hold function starts.

To hold the displayed value at this time, keep the external input hold terminal in the on state.

To cancel the display hold, set the external input hold terminal to the off state.

10.1.3. Operation using a serial communication command

The hold function is started by the hold on command "H^C_R^L_F" of the serial communication and is canceled by the hold off command "C^C_R^L_F".

10.2. Hold indicator

The AD-4530 displays that it is in the hold state by turning the HOLD LED on.

10.3. Priority when inputting hold

When inputting a hold, the external input hold terminal has a higher priority than any other operation.

10.4. Over value during hold

If the value is over during the hold, the display is blank.

Ensure that a function with non-displayed data, such as the comparator or output, is processed based on the hold data.

10.5. Hold Modes

10.5.1. Sample hold mode

Holds the display and output when receiving a hold input.

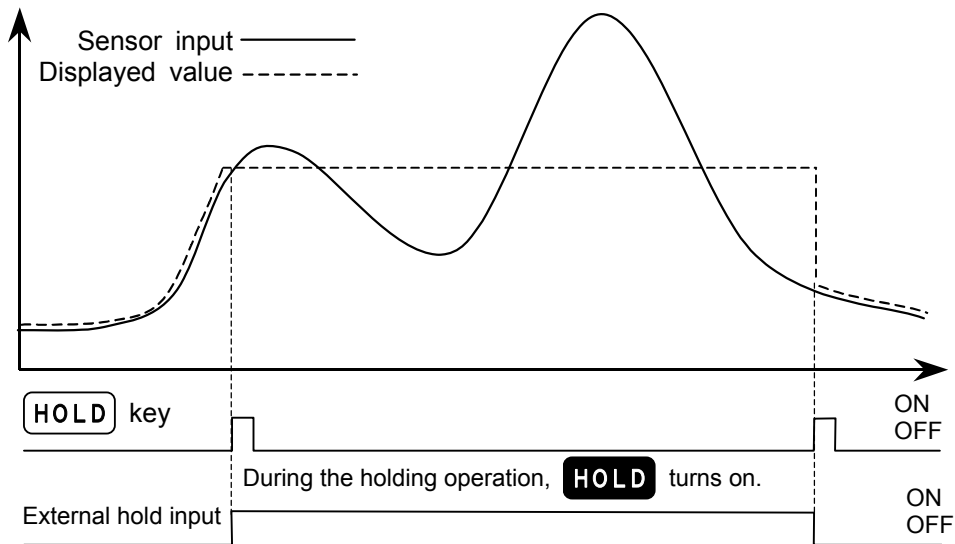

10.5.2. Peak hold mode

Holds the peak value when receiving a hold input.

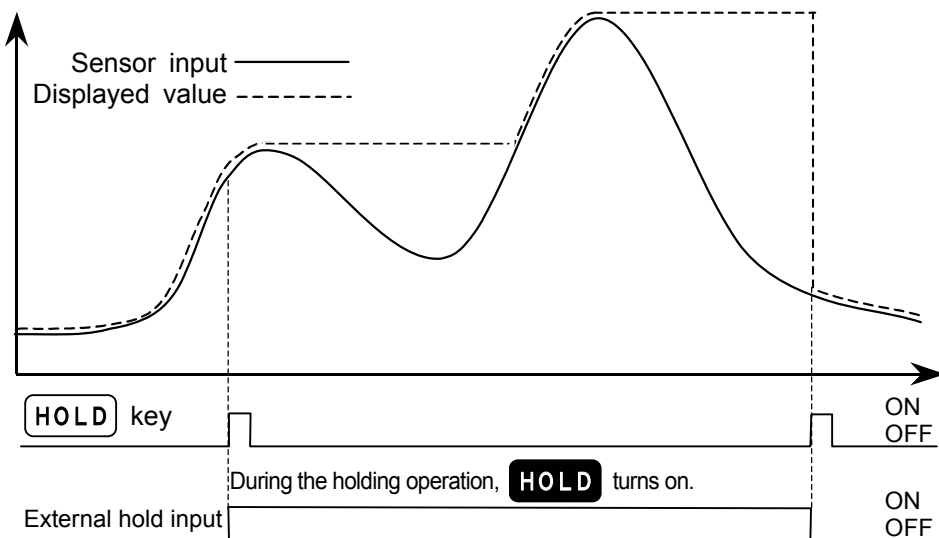

10.5.3. Bottom hold mode

Holds the bottom value when receiving a hold input.

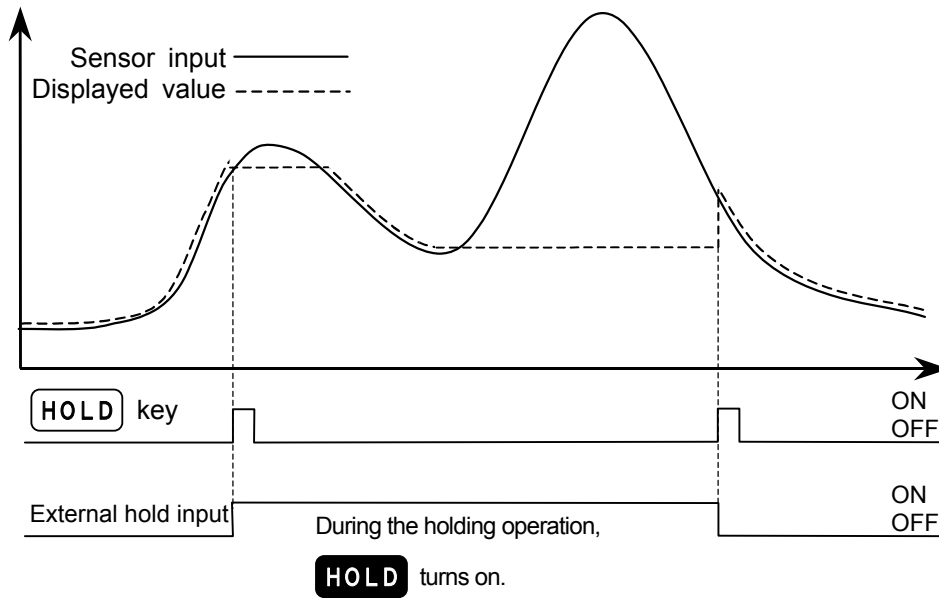

10.5.4. Bipolar peak hold mode

Holds the absolute peak value when receiving a hold input.

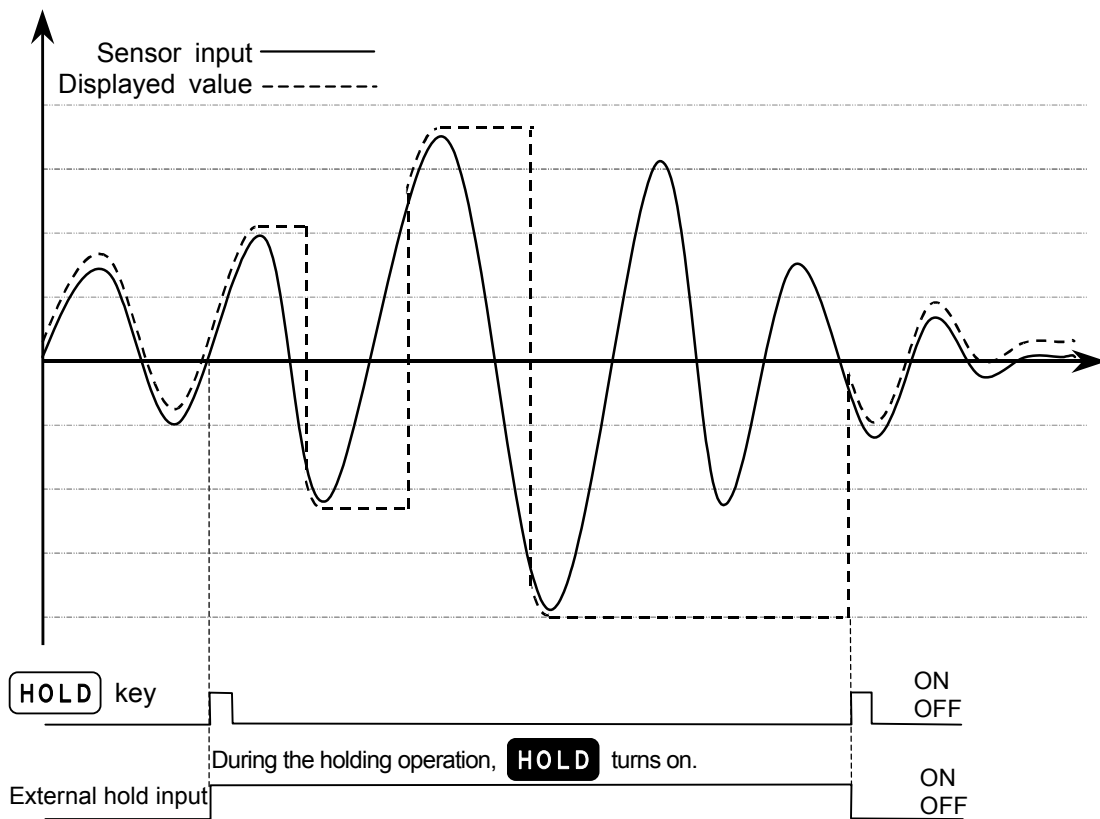

11. LATCH

The AD-4530 can latch the value and output set by the function (F004) in response to the external latch input.

With regard to the output, first the hold operation is processed, then the latch operation.

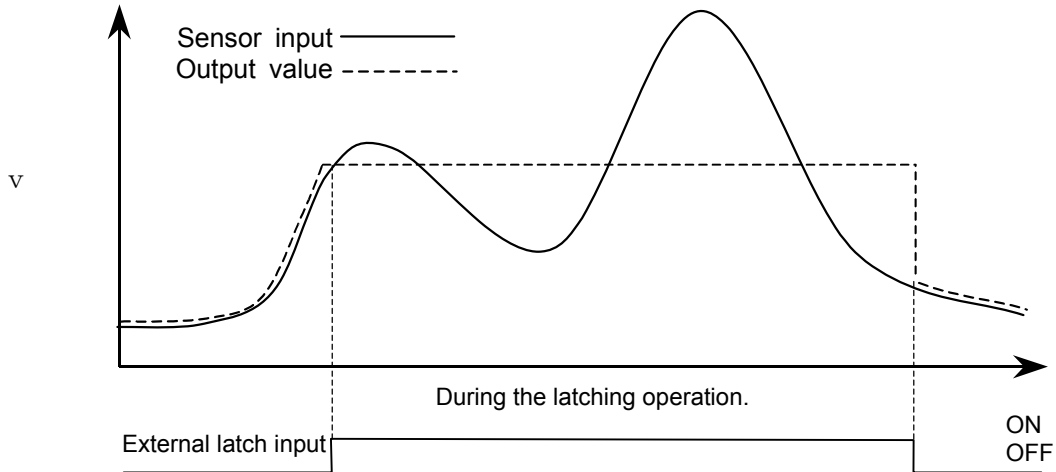

12. COMPARATOR FUNCTION

The comparator function compares the measured value against the set values, and the results are displayed by the LEDs. If the relay option is installed, it outputs the comparison results (HI, OK or LO) from the rear panel relay output terminals.

12.1. Detailed description of the comparator mode

- The relation between the comparison outputs and the upper and lower limit setting values is as shown below:

Comparison result	Comparison condition
HI	Upper limit < Measured value
OK	Lower limit ≤ Measured value ≤ Upper limit
LO	Measured value < Lower limit

* HI is output with a positive over limit, LO is output with a negative over limit.

- Upper limit and lower limit values can be negative.
For example, if the upper limit value is -1000 and the lower limit value is -2000, HI is output for the measured value of -500 and LO is output for the measured value of -2500.
- Make sure that the upper limit value is greater than the lower limit value.

12.2. Setting the upper and lower limit value

Set the upper limit value (F101) and lower limit value (F102) of the function using the following procedure. In weighing mode, press the **HI +/-** or **LO ESC** key to enter the setting mode for the upper or lower limit value.

In the setting mode for the upper or lower limit value, the AD-4530 blinks the **HI** or **LO** LED. (The relay output is not affected.)

The setting value is displayed. Set the value by operating the key.

- ZERO >** Shift the blinking digit to the value to be changed.
- HOLD ^** Change the value of the blinking digit.
- HI +/-** Change the polarity.
- PRINT ↵** Store the setting, and return to weighing mode.
- LO ESC** Cancel the setting, and return to weighing mode.

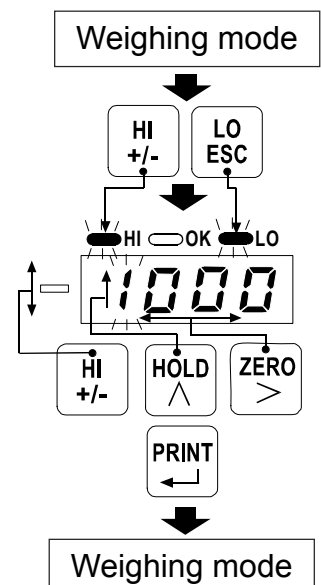

- * If a key is not pressed within 20 seconds in upper or lower limit setting mode, the AD-4530 will cancel the setting, and return to the weighing mode.
- * The decimal point blinks to indicate that a number is being displayed, not a weighing value.

12.3. Example of the comparator mode

Continuous comparison excluding the zero band

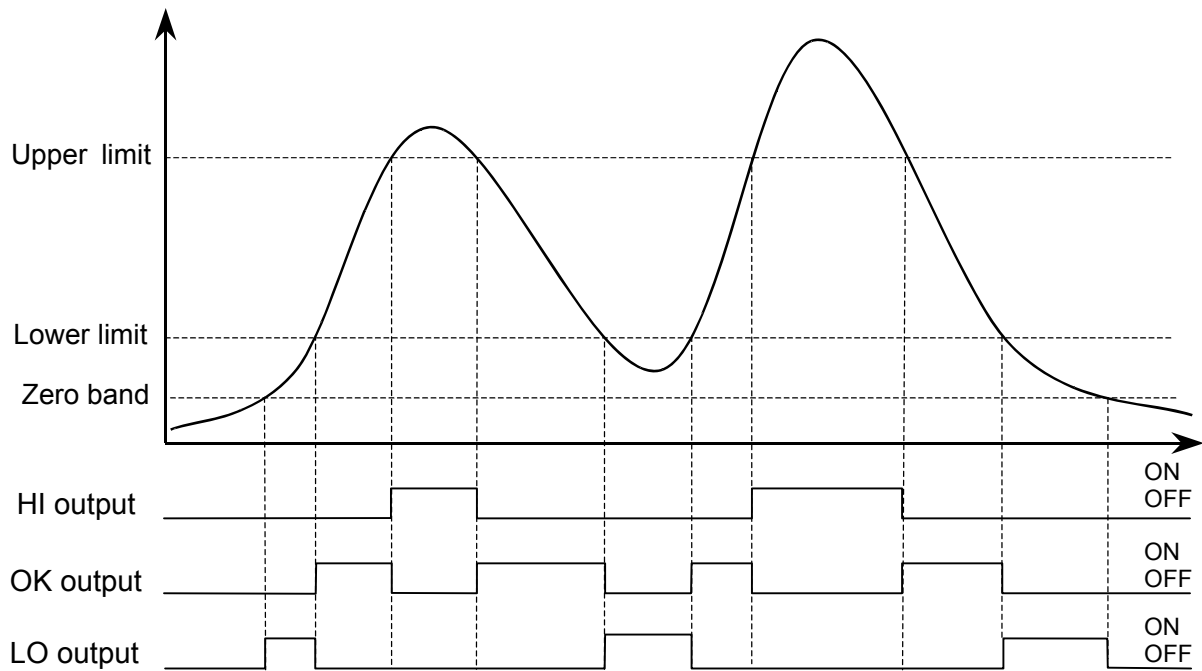

12.4. Hysteresis

A hysteresis width and time is provided for the output relay on/off timing to prevent the output terminals from chattering.

When the measured value exceeds the set value, the relay is turned on. If the measured value falls below the set value and it is further reduced by the hysteresis width, or if the hysteresis time has elapsed, the relay is turned off.

The hysteresis mode, time and width can be set in function modes (F105 to F107).

12.4.1. Hysteresis upward 2-level judgment (F105=1)

□ Relation between HI and OK

When the measured value exceeds the set upper limit value, HI is output immediately. Even if the measured value falls below the upper limit value, OK is not output immediately. OK will be output when the measured value falls below the hysteresis width, or when the hysteresis time has been exceeded.

□ Relation between LO and OK

When the measured value exceeds the set lower limit value, OK is output immediately.

Even if the measured value falls below the lower limit value, LO is not output immediately. LO will be output when the measured value falls below the hysteresis width, or when the hysteresis time has been exceeded.

Judgment example

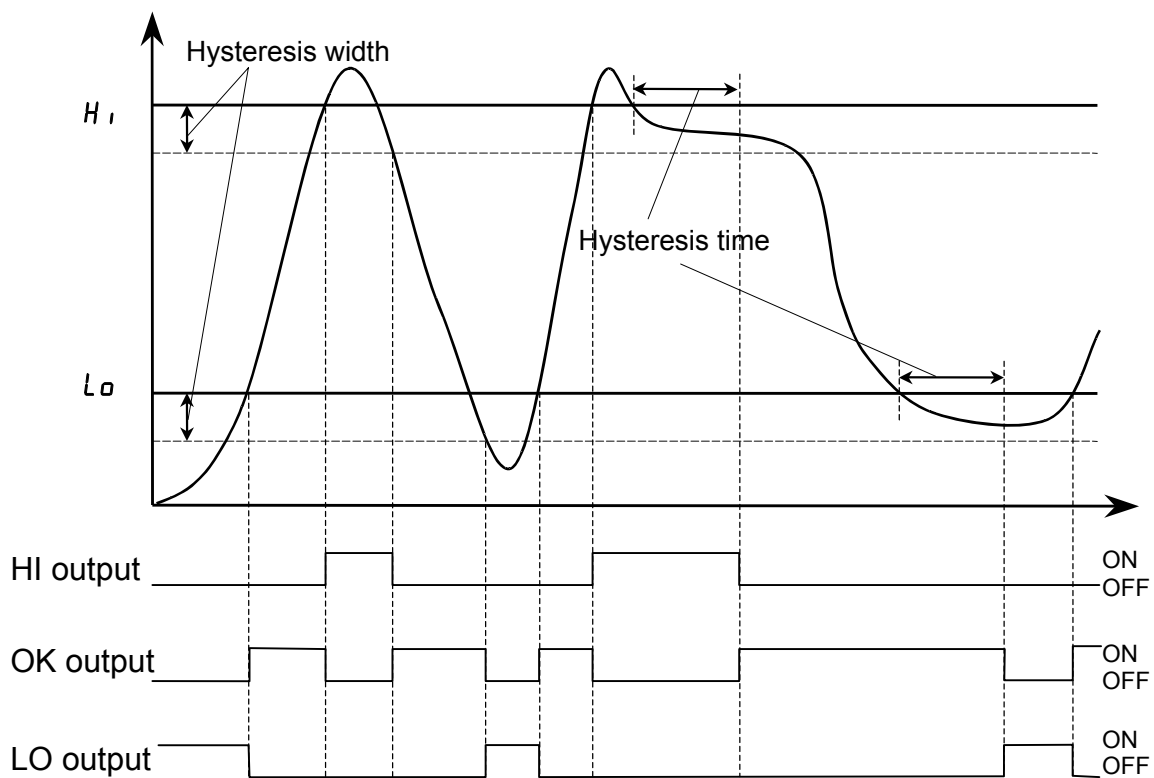

12.4.2. Hysteresis upper/lower limit judgment (F105=2)

□ Relation between HI and OK

When the measured value exceeds the set upper limit value, HI is output immediately. Even if the measured value falls below the upper limit value, OK is not output immediately. OK will be output when the measured value falls below the hysteresis width, or when the hysteresis time has been exceeded.

□ Relation between LO and OK

When the measured value falls below the set lower limit value, LO is output immediately. Even if the measured value exceeds the lower limit value, OK is not output immediately. OK will be output when the measured value exceeds the hysteresis width, or when the hysteresis time has been exceeded.

Judgment example

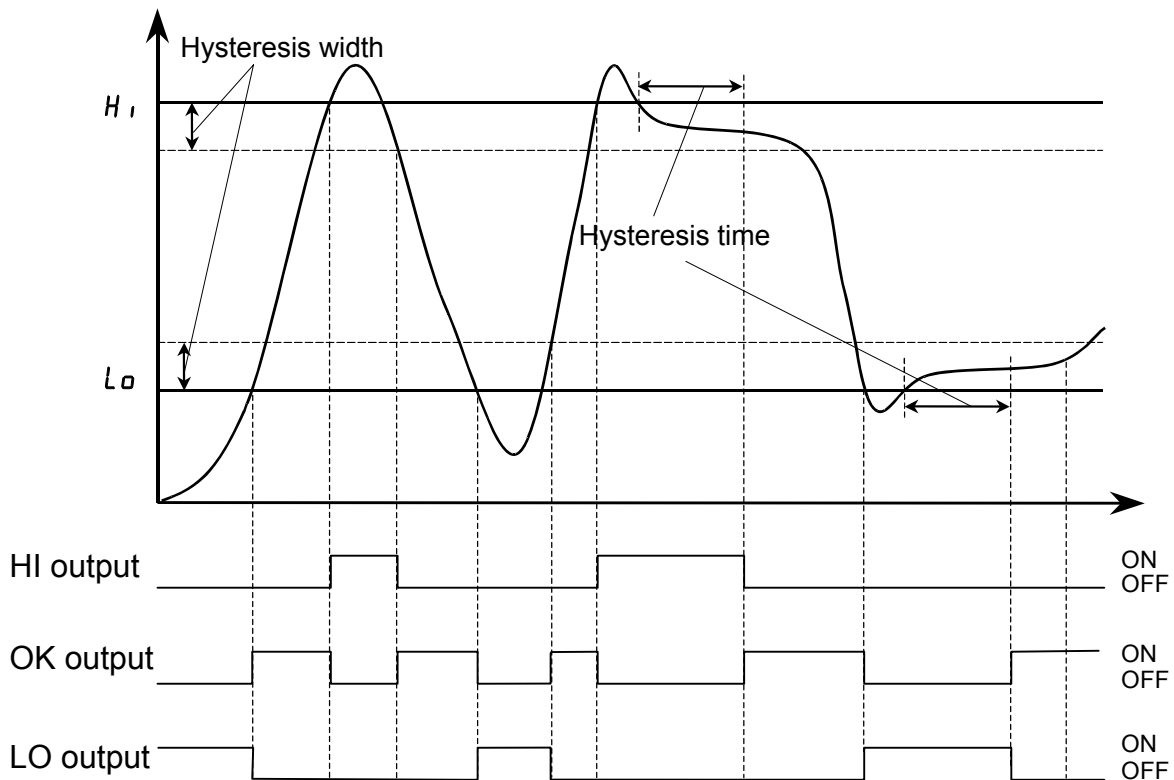

12.4.3. Hysteresis downward 2-level judgment (F105=3)

□ Relation between HI and OK

When the measured value falls below the set upper limit value, OK is output immediately.

Even if the measured value exceeds the upper limit value, HI is not output immediately. HI will be output when the measured value exceeds the hysteresis width, or when the hysteresis time has been exceeded.

□ Relation between LO and OK

When the measured value falls below the set lower limit value, LO is output immediately. Even if the measured value exceeds the lower limit value, OK is not output immediately. OK will be output when the measured value exceeds the hysteresis width, or when the hysteresis time has been exceeded.

Judgment example

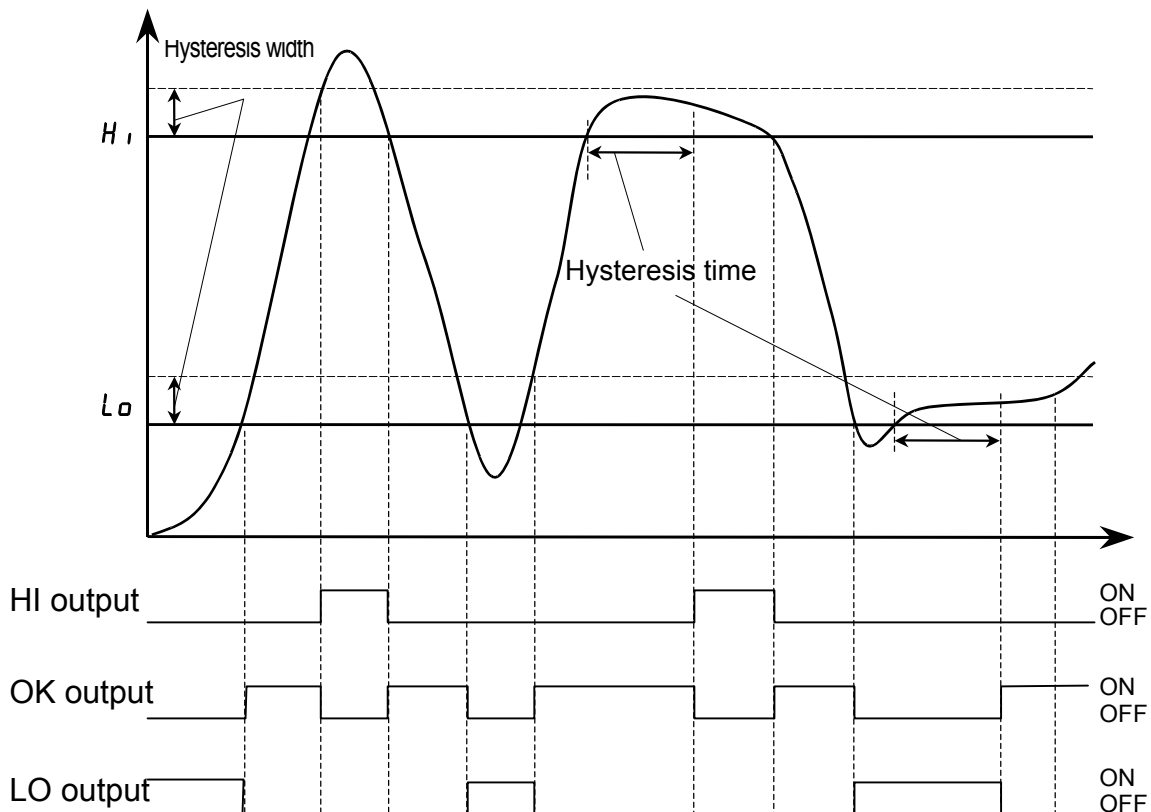

13. ANALOG OUTPUT

The analog output outputs data by converting the measurement value to an analog voltage DAV (0V to 10V) or an analog current DAI (4mA to 20mA). (F201 to F204)

13.1. Analog voltage DAV (0V to 10V)

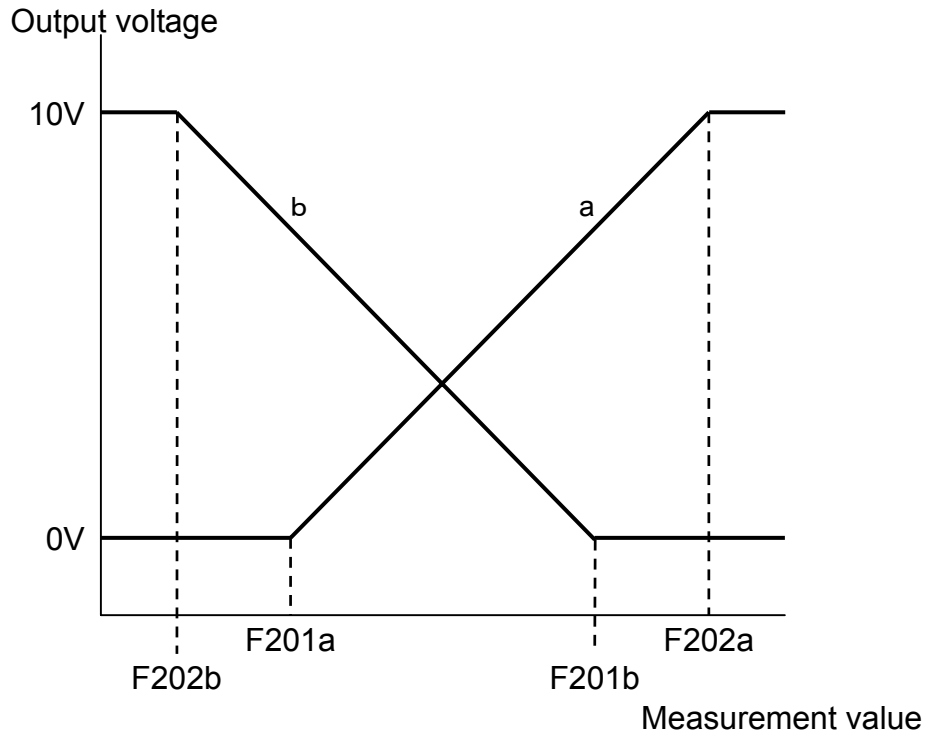

13.2. Analog current DAI (4mA to 20mA)

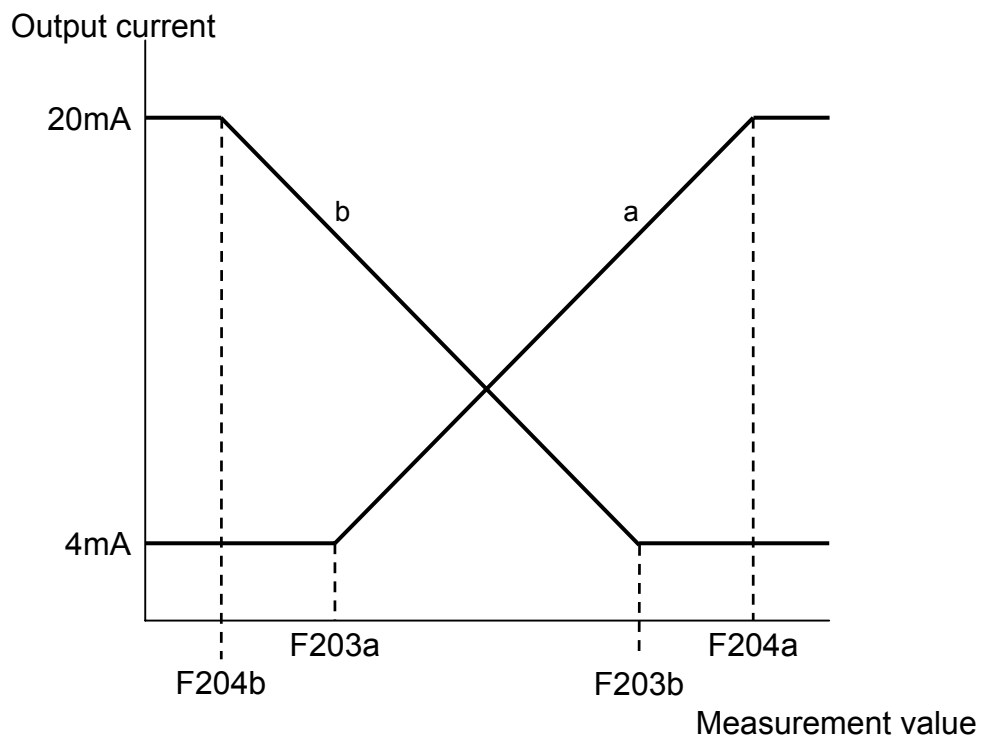

14. SERIAL INPUT AND OUTPUT

14.1. Data output format

Normal measurement value	WT, $\pm 12.34^{C L}_{R F}$
No decimal point	WT, $\pm 01234^{C L}_{R F}$
When over limit	OL, $\pm 99.99^{C L}_{R F}$
When adding the instrument number	@NNWT, $\pm 12.34^{C L}_{R F}$ (NN is the number set with F307)
When adding the unit	WT, $\pm 12.34UUUUU^{C L}_{R F}$ (U is the character code set with F401 to F405)

14.2. Command or response

When receiving an incorrect command, the response is “?”. When a command can not be performed, the response is “I”.

When adding the instrument identification number (ID), add “@NN” (NN is the number set with F307) before the command. In a case where the command does not have the “@NN”, or is an incorrect number, there will be no response. The “@NN” precedes the response.

14.2.1. Data request

Output the display data of when receiving the command.

Command	R
Command example	$R^{C L}_{R F}$
Response example	WT, $\pm 12.34^{C L}_{R F}$

For details about the response, refer to “14.1. Data output format”.

14.2.2. Zero command

Perform zero operation.

Command	Z
Command example	$Z^{C L}_{R F}$
Response example	$Z^{C L}_{R F}$

14.2.3. Hold ON command

Start the hold function.

Command	H
Command example	$H^{C L}_{R F}$
Response example	$H^{C L}_{R F}$

14.2.4. Hold OFF command

Cancel the hold function.

Command	C
Command example	$C_{R\ F}^{C\ L}$
Response example	$C_{R\ F}^{C\ L}$

14.2.5. CAL zero command

Set the input voltage (CF04) at the zero point of the CAL using the input data when receiving the command.

Command	CZ
Command example	$CZ_{R\ F}^{C\ L}$
Response example	$CZ_{R\ F}^{C\ L}$

14.2.6. CAL span command

Set the input voltage (CF05) at the span of the CAL using the input data when receiving the command.

Command	CS
Command example	$CS_{R\ F}^{C\ L}$
Response example	$CS_{R\ F}^{C\ L}$

14.2.7. Function reading command

Confirm the function setting.

The query “?” function number is four characters.

Command example	?F123 $_{R\ F}^{C\ L}$
Response example	F123,±4567 $_{R\ F}^{C\ L}$

14.2.8. Function setting command

Change the function setting.

The function number is four characters and the polarity and setting value is four characters.

Command example	F123,±4567 $_{R\ F}^{C\ L}$
Response example	F123,±4567 $_{R\ F}^{C\ L}$

15. MAINTENANCE

15.1. Error display

When an error is displayed, perform the appropriate remedy.

Display	Cause	Remedy
<i>Ad E</i>	The data can not be acquired from A/D converter.	Repair is required.
<i>EEPE</i>	Correct data cannot be read from EEPROM.	Perform initialization. If the initialization does not clear the error, repair is required.
<i>CALE</i>	Calibration data error.	Perform calibration.
<i>C E*</i>	Calibration error.	Refer to “7.2.Calibration Error”.
<i>dt E</i>	A setting value is out of range.	Check setting values and correct if necessary.

Display	Cause	Remedy
<i>C E2</i>	Voltage at zero point calibration was too far in the positive direction.	Confirm the rating and connection of the load cell.
<i>C E3</i>	Voltage at zero point calibration was too far in the negative direction.	
<i>C E4</i>	The mass value exceeds the rated capacity.	Use a proper mass.
<i>C E5</i>	The mass value is less than the minimum scale value.	Use a proper mass.
<i>C E6</i>	The load cell sensitivity is insufficient.	Confirm the load cell connection. Use a proper mass.
<i>C E7</i>	Voltage at span calibration is less than the zero point.	Confirm the load cell connection.
<i>C E8</i>	When adding a load of the rated capacity, the load cell output voltage is too high.	Use a load cell with a greater rated capacity or set a smaller rated capacity value.



15.2. Checking operation

To confirm the operation of the display, key switch and external input and output. Use check mode.

* The decimal point blinks to indicate that a number is being displayed, not a weighing value.

15.2.1. Entering check mode (Selection mode)

In weighing mode, press the **HI +/-** + **LO ESC** + **PRINT** keys to enter the selection mode for the check mode.

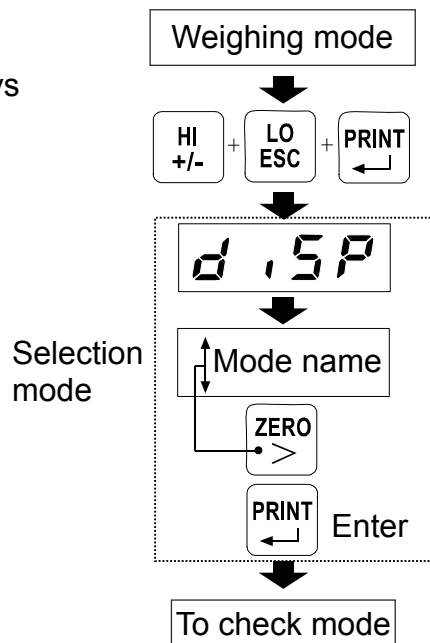

-  Change the item to be checked.
-  Enter the checking mode.
-  Return to weighing mode.



15.2.2. Checking the display

Check the display by turning on each segment and the individual LEDs.

All on / Turn on by digit / Turn on by segment

-  Change the item to be checked. (All on, digit, segment)
-  Proceed to selection mode. (Refer to "15.2.1")

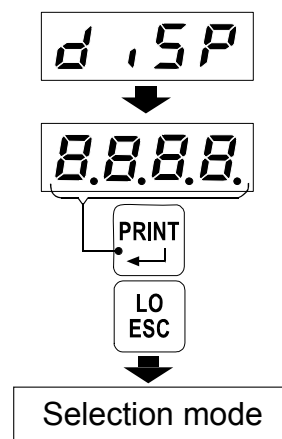

15.2.3. Checking the version

Display the ROM version of the AD-4530 .

-  Proceed to selection mode. (Refer to "15.2.1")

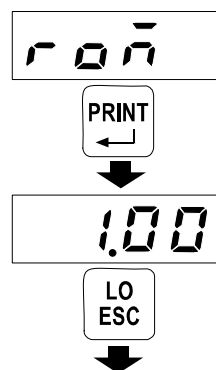

Selection mode

15.2.4. Checking A/D conversion (mV/V)

Check by displaying the input voltage as mV/V.



Set the display to zero.



Proceed to selection mode. (Refer to “15.2.1”)

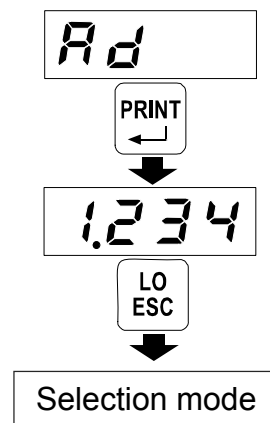

15.2.5. Checking DAV voltage

Check the D/A output voltage in 1V steps.



Increase the output voltage in 1V steps.
(The step after 10V is 0V.)



Proceed to the fine adjustment mode.
(When 0V or 10V, hold for 5 seconds.)



Proceed to selection mode. (Refer to “15.2.1”)

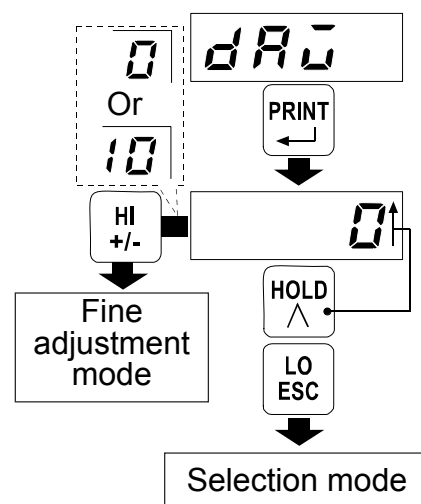

* The output voltage can be finely adjusted using fine adjustment mode.

15.2.6. Checking DAI current

Check the D/A current output in 2 mA steps.



Increase the output current in 2 mA steps.
(The next step after 20 mA is 4 mA.)



Proceed to the fine adjustment mode.
(When 4 mA or 20 mA, press for 5 seconds.)



Proceed to the selection mode. (Refer to “15.2.1”)

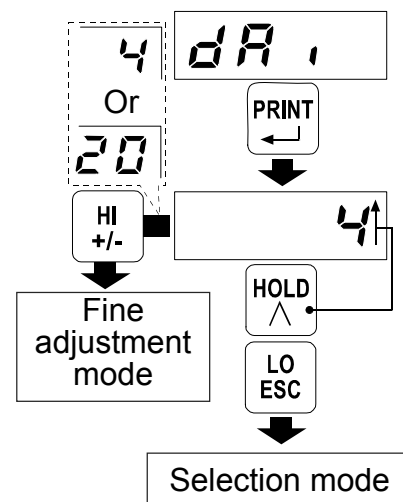

* The output voltage can be finely adjusted using fine adjustment mode.

* Fine adjustment mode

The available adjustment unit is 0.001V for DAV voltage and 0.001mA for DAI current.

When adjusting the 0V or 4mA, the **LO** LED blinks.

When adjusting the 10V or 20mA, the **HI** LED blinks.

- ZERO** Select the adjustment range. (The digit of the range to be adjusted blinks.)
- HOLD** Increase the output within the adjustment range. (If the blinking digit is 9, the next digit is 0, and the value of the next significant digit is increased.)
- HI +/-** Decrease the output with the adjustment range. (If the blinking digit is 0, the next digit is 9, and the value of the next significant digit is decreased.)
- PRINT** Set and save the output.
- LO ESC** Back

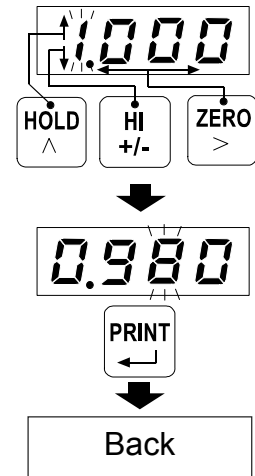

CAUTION

During fine adjustment, be sure to base measurements on a high precision voltmeter and milliamp meter. Otherwise, an error in the output value of the AD-4530 may occur.

15.2.7. Checking I/O

Check the control input and comparator output.

- Ones ON/OFF(1/0) of ZERO input
- Tens ON/OFF(1/0) of HOLD input
- Hundreds ON/OFF(1/0) of LATCH input

- ZERO** HI output and HI blinking
- HOLD** OK output and OK blinking
- PRINT** LO output and LO blinking
- LO ESC** Proceed to selection mode. (Refer to "15.2.1")

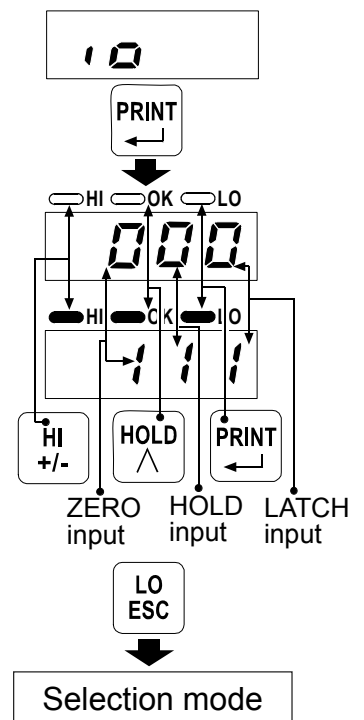





15.2.8. Checking the serial data

Check the serial input and output. (RS-232C/RS-485)

“WT,4530” is output with the stream or manual print mode.



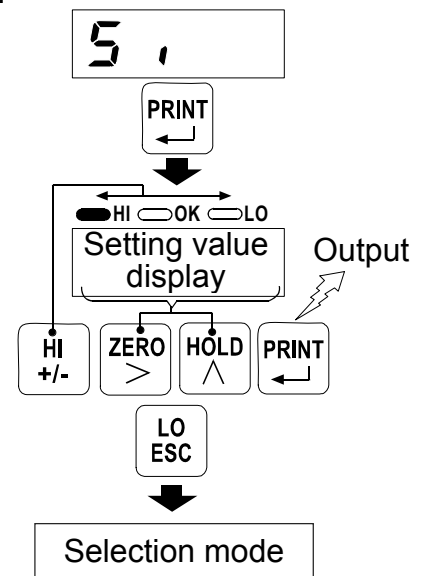

When receiving the “R” command, OK turns on.

-  Switch between stream mode (HI is turned on) or manual print mode (LO is turned on).
-  While this key is pressed, the baud rate of the setting is displayed.
-  While this key is pressed, the data bit length, parity, stop bit and terminator of the setting is displayed.
-  Output the data.
-  Proceed to selection mode. (Refer to “15.2.1”)



15.2.9. Checking the keys

Check the state of each key.

-  Ones
-  Tens
-  Hundreds
-  Thousands
-  Turn on the minus LED. (If you want to proceed to the selection mode, press this key twice quickly.)

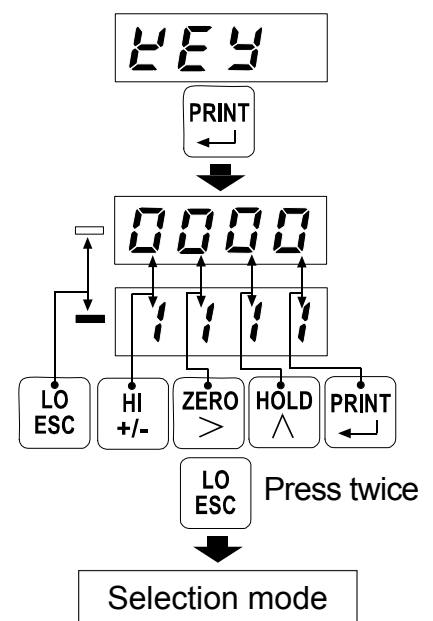

15.2.10. Checking the DZ memory

Check by displaying how much space is available in DZ memory as a percentage.

-  Proceed to selection mode. (Refer to “15.2.1”)

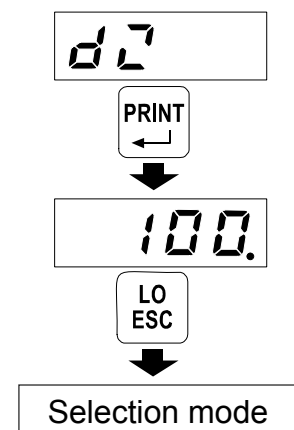

15.2.11. Initialization

Initialize each setting value.

Functions initialized:

“iniF” Initialize the F functions.

“iniC” Initialize the F functions and CF functions.

“iniA” Initialize the F functions and CF functions.
Initialize DAV and DAI data.

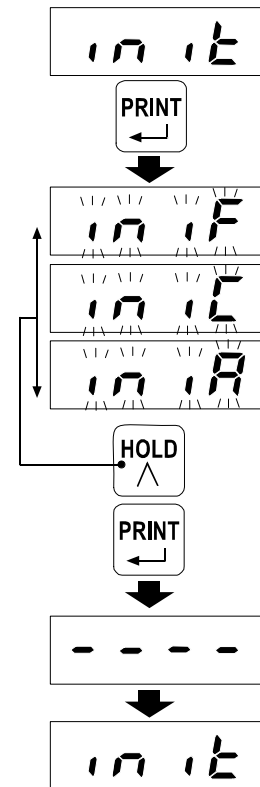





16. SETTING LIST

When performing maintenance, use the following list as a memo.

When inquiring about the product, mention the user settings.

16.1. Calibration (C function)

Function No. Setting range	Description	Default value	User setting
<i>CF01</i> 0 to 3	Decimal point position 10 ⁿ digit.	<i>0</i>	
<i>CF02</i> 1 to 50	Minimum division; <i>1:1</i> <i>10:10</i> <i>2:2</i> <i>20:20</i> <i>5:5</i> <i>50:50</i>	<i>1</i>	
<i>CF03</i> 1 to 9999	Maximum weighing capacity.	<i>7000</i>	
<i>CF04</i> -7.000 to 7.000	Input voltage from the load cell at zero point. □.□□□mV/V	<i>0.000</i>	
<i>CF05</i> 0.001 to 9.999	Input voltage from the load cell at span. □.□□□mV/V	<i>7.000</i>	
<i>CF06</i> -9999 to 9999	Display value for span.	<i>7000</i>	
<i>CF07</i> 0 to 100	Zero adjustment range. Expressed in percent of the rated capacity with the calibration zero point as the center.	<i>100</i>	
<i>CF08</i> 0.0 to 5.0	Zero tracking time. (Unit: second) When <i>0.0</i> , zero tracking is not performed.	<i>0.0</i>	
<i>CF09</i> 0.0 to 9.9	Zero tracking width. (Unit: 0.1 d) When <i>0.0</i> , zero tracking is not performed.	<i>0.0</i>	
<i>CF10</i> 0 to 2	Power on zero: <i>0</i> : Digital zero off <i>1</i> : Perform digital zero again <i>2</i> : Use state when the power was turned off	<i>0</i>	
<i>CF11</i> 1 to 2	Zero operation: <i>1</i> : On with  , off with  +  <i>2</i> : On or off with  + 	<i>1</i>	

16.2. Basic Functions

Function No. Setting range	Description	Default value	User setting
F001 0000 to 1111	Disable keys: 0 : Enabled 1 : Disabled	0000 (Binary)	
F002 0 to 11	Digital filter: 0 : Off 6 :0.5 Hz 1 :2.5 Hz 7 :0.35 Hz 2 :2.0 Hz 8 :0.25 Hz 3 :1.5 Hz 9 :0.20 Hz 4 :1.0 Hz 10 :0.15 Hz 5 :0.7 Hz 11 :0.10 Hz	4	
F003 0 to 4	Hold mode: 0 : Off 1 : Sample hold 2 : Peak hold 3 : Bottom hold 4 : Bipolar peak hold	1	
F004 0000 to 1111	LATCH function: 0 : Off 1 : On	0000 (Binary)	

16.3. Comparator

Function No. Setting range	Description	Default value	User setting
F101 -9999 to 9999	Upper limit value of comparator.	0000	
F102 -9999 to 9999	Lower limit value of comparator.	0000	
F103 0 to 2	Comparator mode: 0 :Off 1 :On when the measured value is not near zero 2 :Always on	2	
F104 -9999 to 9999	Set the near zero range for comparator mode.	0000	
F105 1 to 3	Hysteresis direction: 1 :Upward 2-level judgment 2 :Upper / lower limit judgment 3 :Downward 2-level judgment	2	
F106 0.0 to 5.0	Hysteresis time. (Unit: 0.1 second) When 0.0 , the hysteresis is not used.	0.0	
F107 00 to 99	Hysteresis width. (d) When 00 , the hysteresis is not used.	99	

16.4. Analog

Function No. Setting range	Description	Default value	User setting
<i>F201</i> -9999 to 9999	DAV 0V output	<i>0000</i>	
<i>F202</i> -9999 to 9999	DAV 10V output	<i>1000</i>	
<i>F203</i> -9999 to 9999	DAI 4 mA output	<i>0000</i>	
<i>204</i> -9999 to 9999	DAI 20 mA output	<i>1000</i>	

16.5. Serial Communication

Function No. Setting range	Description	Default value	User setting
<i>F301</i> 2.4 to 38.4	Baud rate: <i>2.4</i> :2400 bps <i>4.8</i> :4800 bps <i>9.6</i> :9600 bps <i>19.2</i> :19200 bps <i>38.4</i> :38400 bps	<i>2.4</i>	
<i>F302</i> 7 to 8	Data bit length: <i>7</i> :7 bits <i>8</i> :8 bits	<i>7</i>	
<i>F303</i> 0 to 2	Parity: <i>0</i> :None <i>1</i> : Odd <i>2</i> : Even	<i>2</i>	
<i>F304</i> 1 to 2	Stop bit: <i>1</i> :1 bit <i>2</i> :2 bits	<i>1</i>	
<i>F305</i> 1 to 2	Terminator: <i>1</i> :CRLF <i>2</i> :CR	<i>1</i>	
<i>F306</i> 1 to 2	Communication mode: <i>1</i> : Stream <i>2</i> : Manual print	<i>1</i>	
<i>F307</i> 00 to 99	Model No. When set to <i>00</i> , the ID is not added.	<i>00</i>	
<i>F401</i> <i>F402</i> <i>F403</i> <i>F404</i> <i>F405</i> 00 to 7F	Unit character (5 character) All characters after <i>00</i> are ignored.	<i>00</i> <i>00</i> <i>00</i> <i>00</i> <i>00</i> (Hexadecimal)	

17. EXTERNAL DIMENSIONS

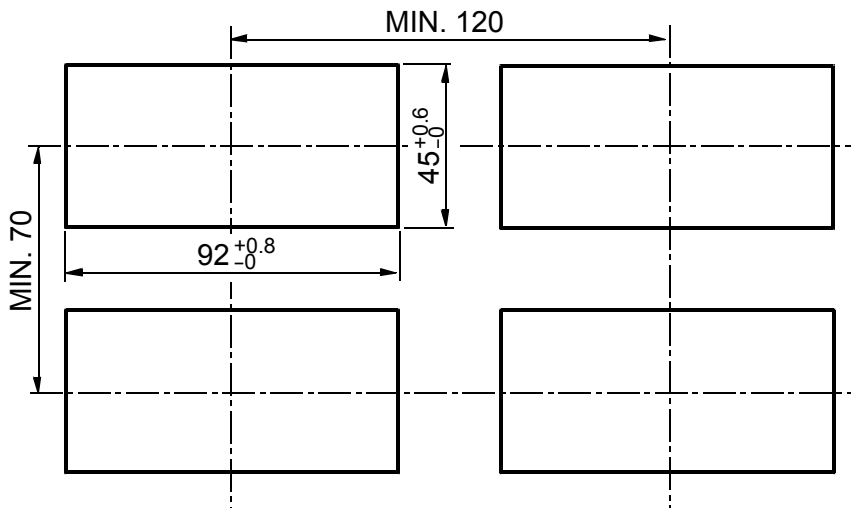
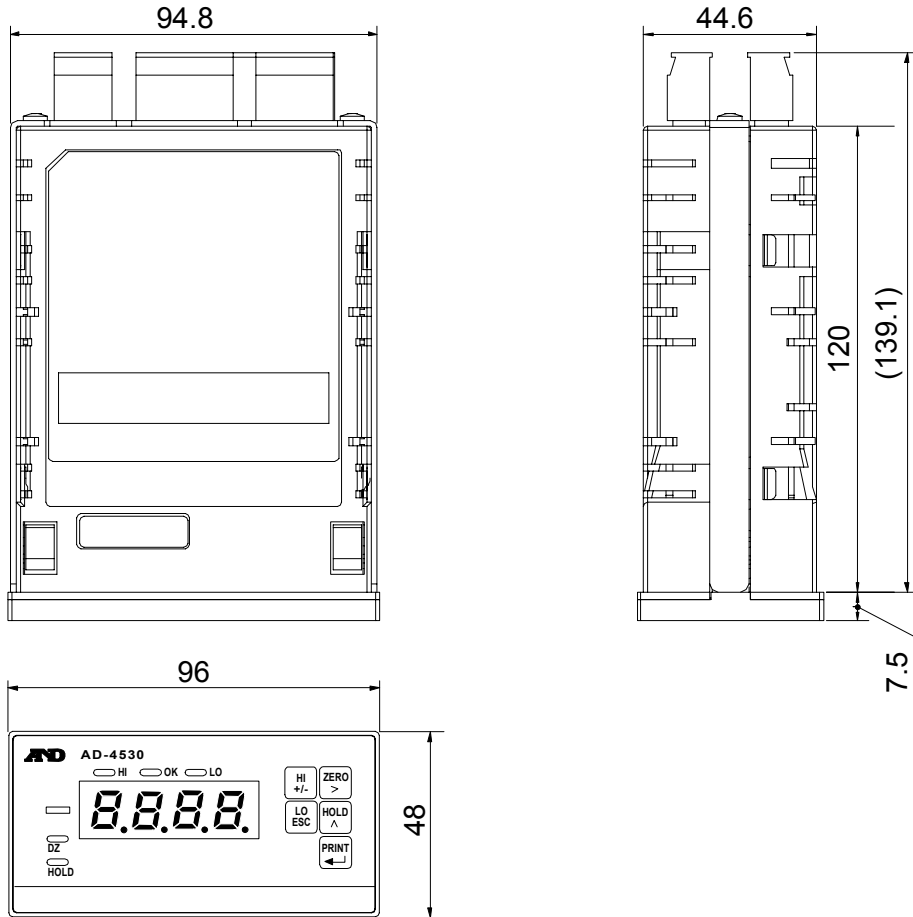

Panel cutout dimensions / Separation

*Maintain the intervals above when installing

UNIT: mm



A&D Company, Limited

3-23-14 Higashi-Ikebukuro, Toshima-ku, Tokyo 170-0013 JAPAN
Telephone: [81] (3) 5391-6132 Fax: [81] (3) 5391-6148

A&D ENGINEERING, INC.

1756 Automation Parkway, San Jose, California 95131 U.S.A.
Telephone: [1] (408) 263-5333 Fax: [1] (408)263-0119

A&D INSTRUMENTS LIMITED <UK Office>

Unit 24/26 Blacklands Way, Abingdon Business Park, Abingdon, Oxfordshire OX14 1DY United Kingdom
Telephone: [44] (1235) 550420 Fax: [44] (1235) 550485

A&D INSTRUMENTS LIMITED <German Sales Office>

Große Straße 13 b 22926 Ahrensburg Deutschland
Telefon: [49] (0) 4102 459230 Telefax: [49] (0) 4102 459231

A&D Australasia Pty Ltd.

32 Dew Street, Thebarton, South Australia 5031 AUSTRALIA
Telephone: [61] (8) 8301-8100 Fax: [61] (8) 8352-7409

A&D KOREA Limited 한국에이.엔.디(주)

대한민국 서울시 영등포구 여의도동 36-2 맨하탄 빌딩 8층
(8th Floor, Manhattan Bldg. 36-2 Yoido-dong, Youngdeungpo-ku, Seoul, KOREA)
전화: [82] (2) 780-4101 팩스: [82] (2) 782-4280

A&D RUS CO., LTD.

Компания Эй энд Ди Рус
121357, Российская Федерация, г.Москва, ул. Вереysкая, дом 17
(Bldg. 17, Vereyskaya st., Moscow, 121357 RUSSIAN FEDERATION)
тел.: [7] (495) 937-33-44 факс: [7] (495) 937-55-66

A&D Instruments India Private Limited ऐ&डी इन्स्ट्रूमेन्ट्स इण्डिया प्रा० लिमिटेड

509, उद्योग विहार , फेस -5, गुडगांव - 122016, हरियाणा , भारत
(509, Udyog Vihar, Phase-V, Gurgaon - 122 016, Haryana, India)
फोन : 91-124-4715555 फैक्स : 91-124-4715599