

(UK 2848)



V(0)a

United Kingdom of Great Britain and Northern Ireland

Certificate of EC type-approval of a measuring instrument

Number: UK 2848

issued by the Secretary of State for Innovation, Universities & Skills
Notified Body Number 0126

In accordance with the requirements of the Non-automatic Weighing Instruments Regulations 2000 (SI 2000/3236) which implement, in the United Kingdom, Council Directive 90/384/EEC, this certificate of EC type-approval has been issued to:

**A & D Instruments Ltd
24 Blacklands Way
Abingdon Business Park
Abingdon
Oxon. OX14 1DY
United Kingdom**

in respect of a family of Class III non-automatic weighing instruments designated the SJ-.../SJ-12K.

Instrument Model	SJ-1000	SJ-2000	SJ-5000	SJ-12K
Max (Max1 / Max2)	1000	2000	5000	10 kg / 12 kg
e (e1 / e2)	1 g	2 g	5 g	10 g / 20 g
n (n1 / n2)	1000	1000	1000	1000 / 600
Min	20 g	40 g	100 g	200 g
Temperature range	- 10 °C / + 40 °C			

The necessary data (principal characteristics, alterations, securing, functioning etc) for identification purposes and conditions (when applicable) are set out in the descriptive annex to this certificate.

A handwritten signature in black ink, appearing to read 'G. Stones', is positioned above the printed name of the signatory.

Signatory: G. Stones
for Chief Executive
National Weights & Measures Laboratory
Department for Innovation, Universities & Skills
Stanton Avenue
Teddington
Middlesex TW11 0JZ
United Kingdom

Date: 04 July 2008
Valid Until: 03 July 2018
Reference No: T1128/0162

Descriptive Annex

1 NAME AND TYPE OF INSTRUMENT

The SJ-.../SJ-12K Series is a family of Class III, mains or battery-operated, self-indicating, single or dual-interval, non-automatic weighing instruments. It comprises the SJ-1000, SJ-2000, SJ-5000, and SJ-12K models and their variants.

2 DESCRIPTION

2.1 Construction

2.1.1 Mechanical

Main features:

- Plastic weighing pad & load receptor
- Plastic housing construction
- Operator's keypad
- Level indicator
- Operator display

2.1.2 Devices

- Initial zero setting device $\leq 20\%$ of Max
- Semi-automatic zero setting device $\leq 4\%$ of Max
- Zero tracking device $\leq 4\%$ of Max
- Zero indicator
- Net indicator
- Semi-automatic subtractive tare balancing device
- Automatic power-off function
- Gravity compensation

2.1.3 Load cell

The load cell(s) are as defined in the table below.

Instrument Model	SJ-1000	SJ-2000	SJ-5000	SJ-12K
Load Cell	TS103-1K	TS103-2K	TS103-5K	TS103-10K
Rated Capacity	9.8 N	19.6 N	49 N	98 N

2.2 Operation

2.2.1 Switch-on

At switch-on, the instrument performs a self-test during which all the relevant segments of the display are lit. The instrument attempts to set zero provided that it is within a range not exceeding 20 % of its capacity.

2.2.2 Zero-tracking

Zero-tracking operates provided that the instrument is within a range not exceeding 4% of its capacity.

2.2.3 Semi-automatic zero setting

The zero button operates provided that the instrument is within a range not exceeding 4 % of its capacity.

2.2.4 Over- and under-range

If the load is less than gross zero, then the display shows a “-” sign before the value.

The load may be shown up to a maximum of eight divisions above Max, above which the weight indications are inhibited and replaced by an error “E”.

2.2.5 Tare

Subtractive tare balancing can be performed.

3 TECHNICAL DATA

3.1 Power supply

Any compatible AC mains adaptor may be used to supply 100 V, 120 V and 230 V to the instrument.

The instrument operates from four internally fitted 1.5 V batteries (D size). If the battery or supply voltage is too low, the display shows “Lb”.

3.2 Metrological characteristics

Instrument Model	SJ-1000	SJ-2000	SJ-5000	SJ-12K
Max (Max1 / Max2)	1000	2000	5000	10 kg / 12 kg
e (e1 / e2)	1 g	2 g	5 g	10 g / 20 g
n (n1 / n2)	1000	1000	1000	1000 / 600
Min	20 g	40 g	100 g	200 g
Maximum Tare-balancing effect	T = - 1000 g	T = - 2000 g	T = - 5000 g	T = - 9.99 kg
Temperature range	- 10 °C / + 40 °C			

4 PERIPHERAL DEVICES AND INTERFACES

4.1 There are no interfaces, so therefore no peripheral devices can be connected.

5 APPROVAL CONDITIONS

The certificate is issued subject to the following conditions:

5.1 Legends

5.1.1 The instrument bears the following legends:

- Max
- Min
- e =
- Class III
- CE marking
- Green M sticker
- Manufacturer's mark or name
- Serial number
- Certificate number

6 SECURING AND VERIFICATION MARKS

6.1 The data plate is located on the right hand side of the instrument. It is of a form such that it is destroyed if removed.

6.2 The instrument is sealed as shown in Figure 3 using a wire screw locking method or using a suitable tamperproof/evident label. A seal is placed over the calibration switch cover which prevents access to the calibration switch.

6.3 Components that may not be dismantled or adjusted by the user must be secured by a suitable mark placed over the securing screws. The securing mark may be either:

- a mark of the manufacturer and/or manufacturer's representative, or
- an official mark of a verification officer.

6.4 Verification marks, and the CE-marking, are located on, or adjacent to, the data plate.

7 ALTERNATIVES

There are at present no authorised alternatives.

8 ILLUSTRATIONS

- Figure 1 A&D Instruments SJ Series
Figure 2 Display and buttons
Figure 3 Sealing arrangements

CERTIFICATE HISTORY

ISSUE NO.	DATE	DESCRIPTION
UK 2848	04 July 2008	Type approval first issued

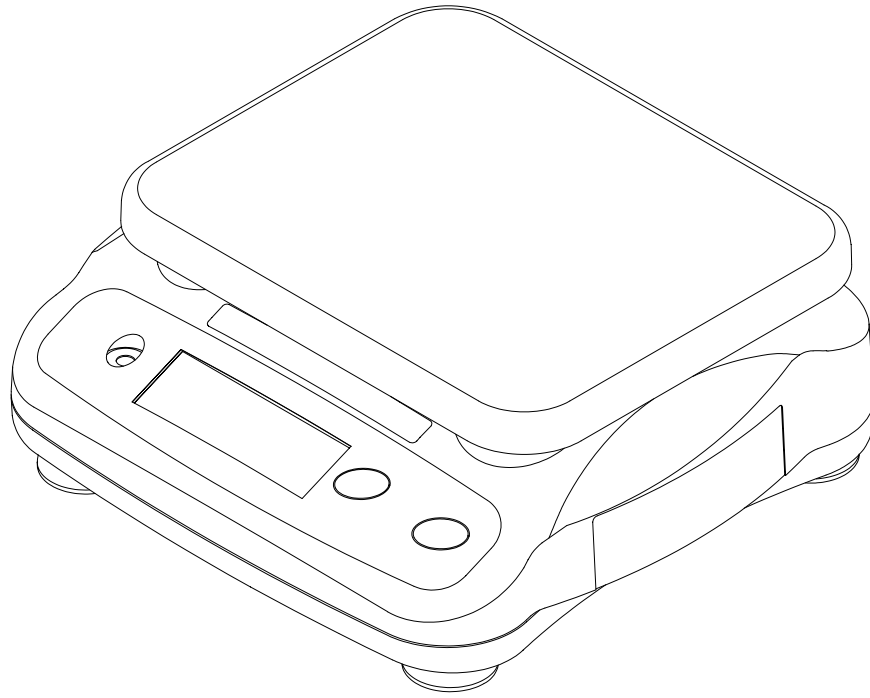
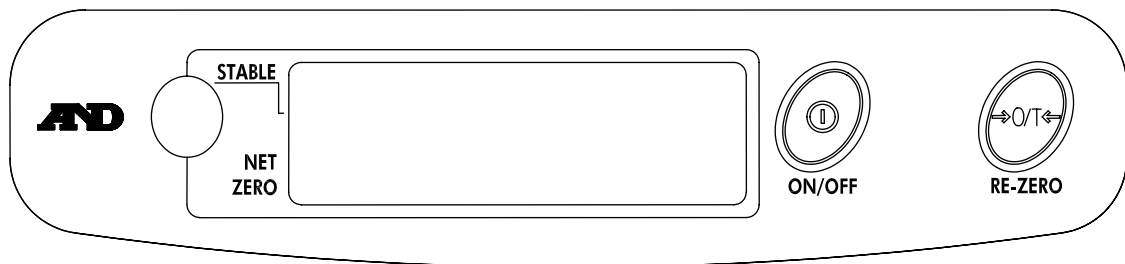

Figure 1 A&D Instruments SJ Series



Model Label

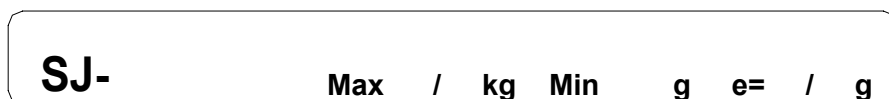

Figure 2 Display and buttons

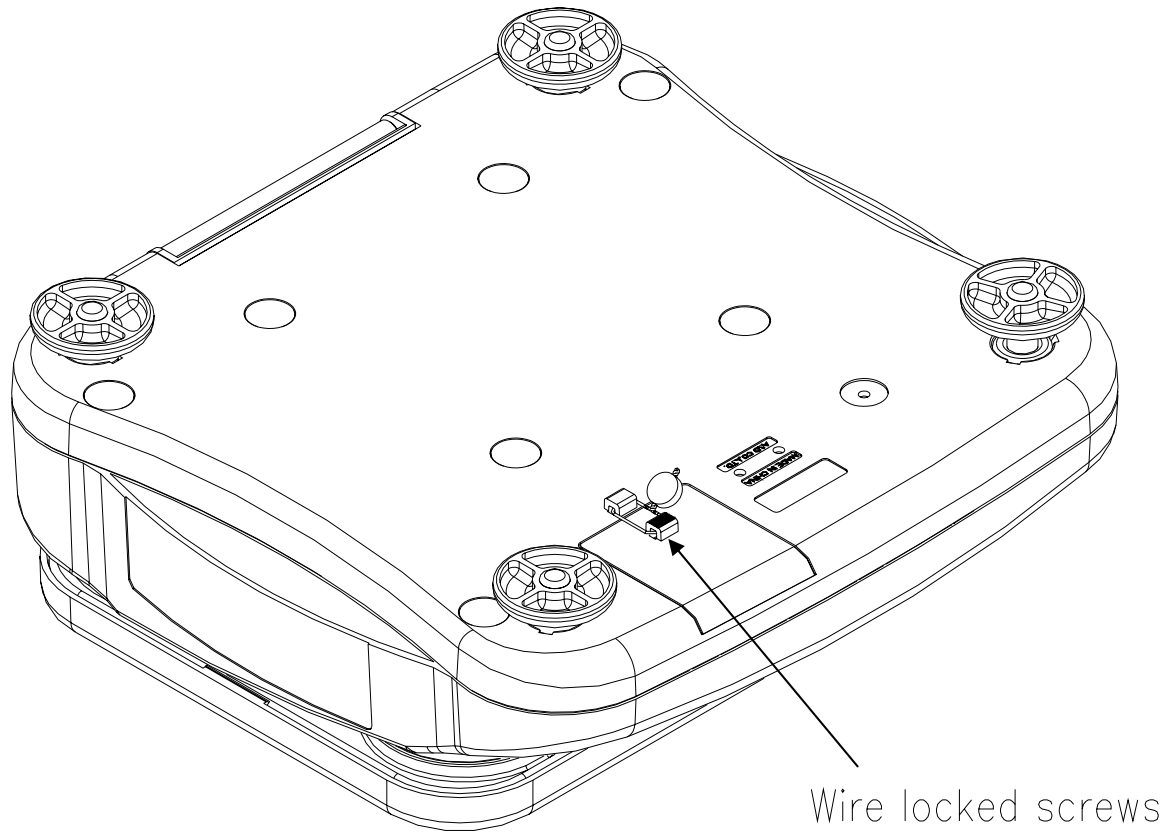

Figure 3 Sealing arrangements