

Instruction Manual

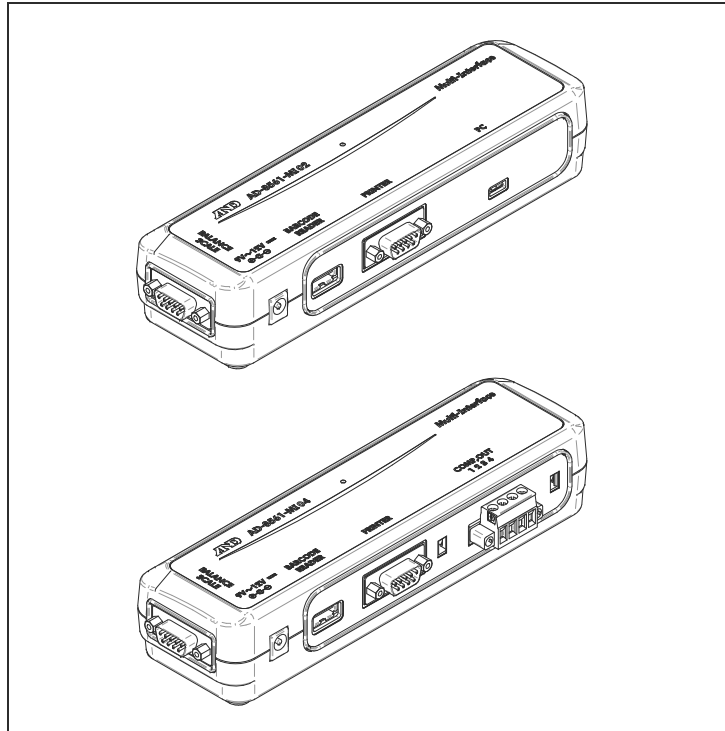

1WMPD4004599



Safety Precautions

To prevent accidents due to inappropriate handling, this manual contains the following warning signs and marks. The meanings of these warning signs and marks are as follows.

	A potentially hazardous situation that could result in death or serious injury, if not avoided.
	A potentially hazardous situation which, if not avoided, may result in personal injury or property damage.

- No parts of this manual may be reproduced without permission. This manual may not be copied, modified, or translated without the written permission of A&D Company, Limited.
- The contents of this manual are subject to change without notice.
- Please contact A&D if you notice any uncertainty, errors, omissions, etc. in this manual.
- A&D Company, Ltd. bears no liability for direct, indirect, special, or consequential damages due to the operation of this product, even if advised of the possibility of such damage. Furthermore, A&D assumes no liability for claims of rights from third parties. Concurrently, A&D assumes no liability whatsoever for data losses regardless of (3) above.

© 2022 A&D Company, Limited All rights reserved.

Caution

- Do not disassemble the interface. It may cause damage or malfunction, which is not included in the warranty.
- Immediately stop using the interface if an abnormality occurs.

1. Introduction

This manual describes how to handle the Multi-Interface AD8561. Read the instruction manual thoroughly before use. For the information on the AD-8561 and its related products, please refer to the A&D website (<https://www.aandd.co.jp/>).

2. About the AD-8561

2-1. Features

The following operations are enabled when the AD-8561 is connected to the RS-232C output on the GC-series (hereinafter called 'counting scale').

- Transmitting and receiving data from D-sub 9 pin (between the counting scale and a connected device such as a printer)
- Transmitting and receiving data from USB micro B: AD-8561-MI02 only (between the counting scale and a connected device such as PC)
- Comparator output: AD-8561-MI04 only (from the counting scale to a connected device such as a comparator lamp)
- Sending texts to the counting scale from USB Type-A with a barcode reader or keyboard (from a barcode reader/keyboard to the counting scale)

Each color of the LED lights shown below indicates different status.

LED color	AD-8561 status	
Blue	Activating	Communication available
White	A barcode reader or keyboard is connected (HID setting: key mode)	Communication available
Yellow	A barcode reader or keyboard is connected (HID setting: command mode)	Communication available
Yellow (blinking)	An input that exceeds 64 digits is received from a keyboard (Command mode/Refer to '5-2. USB Connector')	Restart the device.
Red (blinking)	Not-supported devices connected to USB Type-A	Immediately remove the USB drive
Red	Error	Restart the device.

(For how to restart the device, refer to '4-1. Connection to Power Supply')

2-2. Precautions for Use

- The power for the AD-8561 can be supplied from the counting scale with an accessory cable. When another cable is used, an AC adapter for power supply may be required. (Refer to '4-1. Connection to Power Supply')
- Make sure to check the rating of the AC adapter before attaching it. Inappropriate power supply may cause malfunction or damage to the internal circuitry.
- Magnets are used for simple fixation.
 - *When there is any magnetically sensitive device such as a balance nearby, they can affect the device. In this case, remove the magnets from the AD-8561.

<How to remove the magnets for attaching the interface>

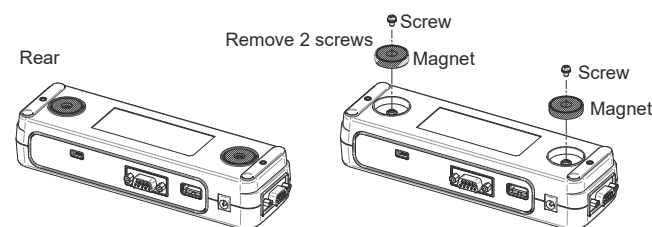

- Magnets are not strong enough to secure the interface to a wall. To attach to a wall, first attach the AD-8561 to a GC-14, an option for the counting scale, with screws, and then attach the GC-14 to a wall (with screws or by hanging it on a wall). For the details, refer to the instruction manual for the GC-14.

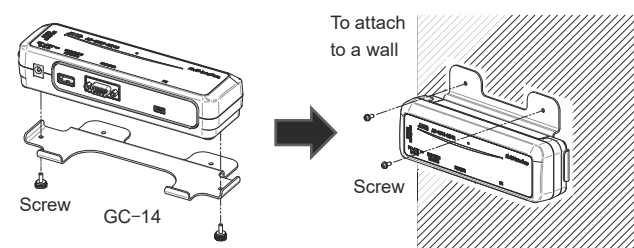

3. Part Names and Accessories

3-1. Main Unit

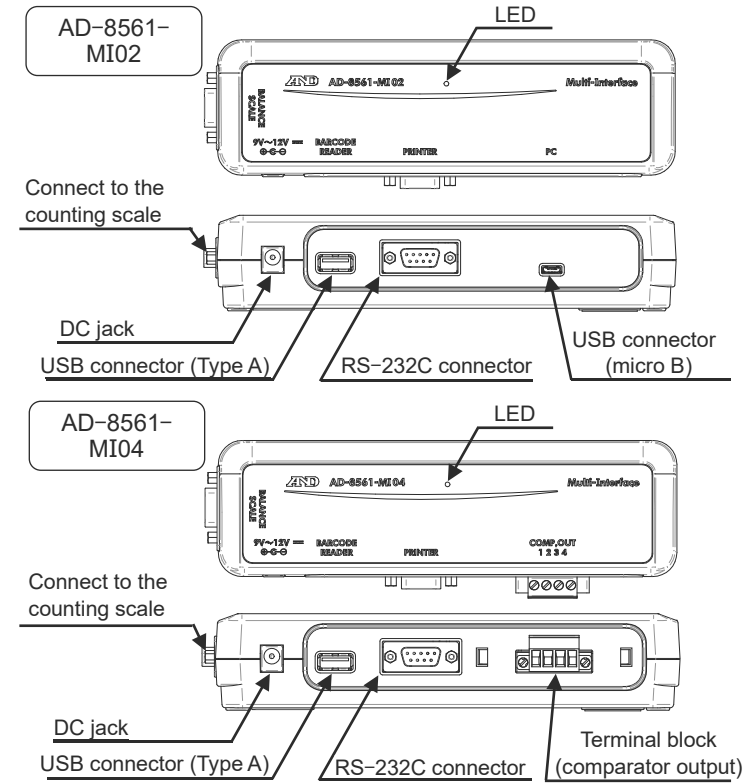

3-2. Accessories

- Instruction manual (This manual)
- Cable (1m, D-sub 9 pin, female-female, for connecting to the counting scale)

4. Connection to Other Devices

4-1. Connection to Power Supply

- Supply power from the counting scale by connecting an accessory cable to the connector on AD-8561 (use a D-sub 9 pin).

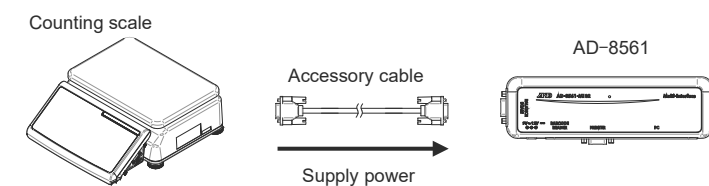

- When the accessory cable is not used, an AC adapter should be used to supply power from the DC jack.

- When using a commercially available cable to which the 9th pin of the connector is not connected
- When communicating between the counting scale and AD-8561 at a distance longer than 1m

*A cable longer than 1m, which is optionally available, is not connected to the 9th pin of the connector and therefore requires power supply from an AC adapter. (Refer to (3) in '8-3. Optional Devices')

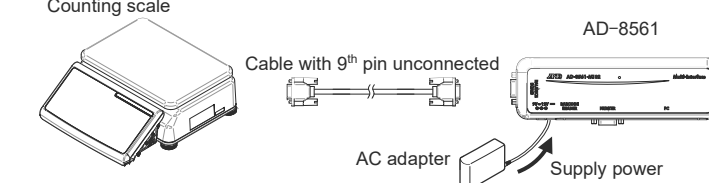

- Make sure to check the specifications when using an AC adapter. An AC adapter with a center negative plug that outputs DC 9 to 12V is usable.
- The main unit is activated when it is connected to the counting scale or when an AC adapter is inserted into the DC jack. Once it is activated, a blue LED light is turned on.
- To restart the interface, remove the cable or AC adapter and confirm that the LED light is turned off. Then, reconnect it to turn the power on.

4-2. Connected Devices

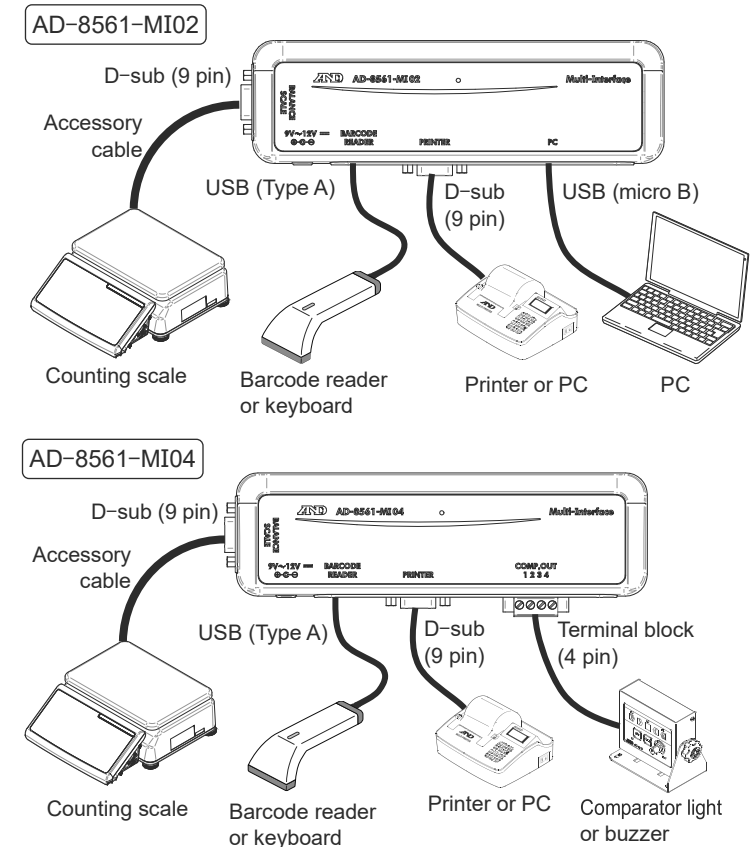

- Set the function F-06-03 of the counting scale to '1.'

5. Communication Specifications

5-1. RS-232C Connector (D-sub 9 pin): PRINTER

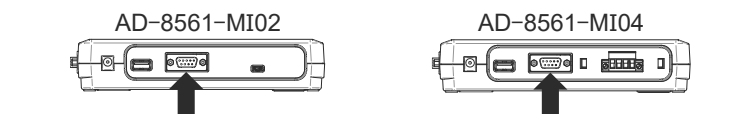

- Communication between the counting scale and a printer (or PC) is operable with an RS-232C interface.

- Transmission system: EIA RS-232C
- Transmission form: Asynchronous, bidirectional, half-duplex
- Data format:

Baud rate *	2400 bps
Bit length *	7 bit
Parity *	EVEN
Start bit	1 bit
Stop bit	1 bit
Code used	ASCII
Terminator	CRLF (CR: 0Dh, LF: 0Ah)

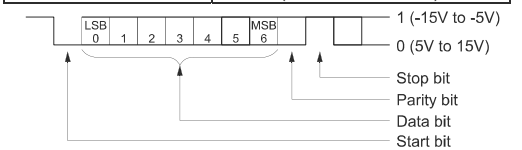

*The settings are changeable (Refer to '6. Functions')

- Pin layout

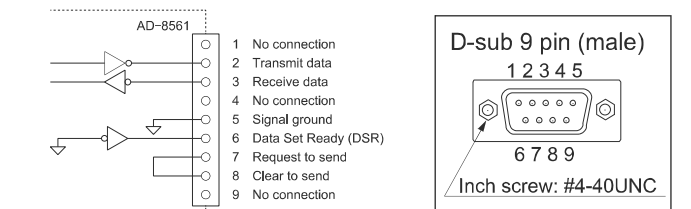

5-2. USB Connector (Type A): BARCODE READER

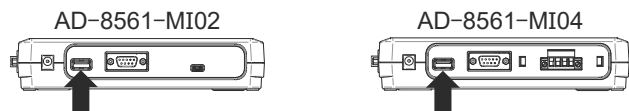

- Attach a barcode reader or keyboard to send entered text to the counting scale.
 - Transmission system : USB 2.0
 - Connector : Type A
 - Device class : HID
- Once the device is connected, the color of the LED light changes from blue to white or yellow.
 - The color does not change if the AD-8561 cannot recognize the connected device. In this case, restart the AD-8561 and reconnect the device.
 - Red LED light blinks when a device of not supported device class is connected. Note that data may be broken if a USB memory is mistakenly attached.
- Modes and data to transmit *Modes are selectable (Refer to '6. Functions').
 - Key mode: To be used when the counting scale searches/registers an ID or item.
 - For searching/registering ID: The last 6 digits of the input data are recognized as an ID.
 - For searching/registering item code: Up to 20 digits from the beginning of the input data are recognized as an item code and forward-matching searching can be done.
 - Command mode: To be used when sending commands to the counting scale
 - For commands, refer to the instruction manual for the counting scale.
 - Up to 64 digits in a string can be transmitted. (The data is deleted without being sent if more than 64 digits are input. Restart the AD-8561 to prevent errors in a subsequent communication data.)

- Caution
 - Barcode reader
 - Set your barcode reader to add a linefeed code 'Enter' to the suffix of data.
 - Keyboard
 - In command mode, the counting scale cannot recognize the input data until 'Enter' key is pressed. Make sure to press 'Enter' key at the end of each data entry. Characters are not shown while being entered.
 - Re-enter from the beginning if wrong characters are entered.
- Characters that can be entered
 - Numerical: 0 - 9
 - Alphabetical: A - Z (Disable caps lock to enter lower-case letters)
 - Symbols: Refer to the instruction manual of the counting scale for symbols that can be entered to the device. The keyboard entry is based on the US keyboard (101 / 104). For the details, please refer to the A&D website.

5-3. USB Connector (micro B): PC (* AD-8561-MI02 only)

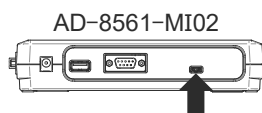

- Communication between the counting scale and a PC via USB interface.
 - Transmission system : USB 2.0
 - Connector : micro B
 - Device class : CDC
 - Transmission form: bidirectional communication with virtual COM port
 - Data format:

Baud rate	19200 bps
Bit length	8 bit
Parity	None

- Supported OS is Windows 7 or later. For the older OS than Windows 10, a USB driver needs to be installed.
- Install a communication tool such as the WinCT in a PC to connect. (Refer to '8-2. Related Software')

5-4. Comparator (Terminal Block): COMPARATOR (* AD-8561-MI04 only)

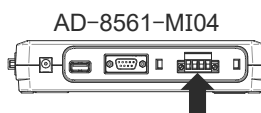

- Relay outputs the comparator result of the counting scale.
- Maximum rating of the relay output
 - Maximum voltage: 50V DC
 - Maximum current: 100mA DC
 - Maximum on-resistance: 8 Ω
- The upper/lower limit values cannot be set with the AD-8561. They should be set with the counting scale.
- Set the function F-06-10 for the counting scale to '1.'
- Pin layout

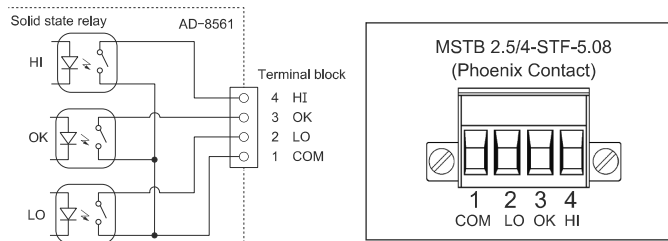

5-5. Connector for the Counting Scale (D-sub 9 pin): BALANCE / SCALE



- Performs communication with the counting scale via RS-232C interface
 - Transmission system and transmission form are same as those mentioned in '5-1. RS-232C Connector (D-sub 9 pin): PRINTER.'
 - Data format:

Baud rate	19200 bps
Bit length	8 bit
Parity	None
- Pin layout

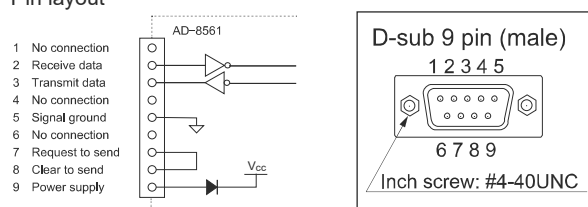

- Use the accessory cable (D-sub 9 pin, 1m) to connect it to the counting scale.
- Supply power to AD-8561 from the 9th pin of this connector. (Refer to '4-1. Connection to Power Supply')
- When operating the function setting for AD-8561 with this connector, supply power with an AC adapter by connecting to a PC instead of the counting scale with a crossover cable.

6. Functions

The function setting can be operated with commands.
1. Connect a PC to AD-8561 to send commands for the function list.



- '<AK>' is returned when the setting is saved.
- If there is no response, check the communication settings to send commands again.

Response	Meaning	Action to take
<AK>	Saved	Restart the device to apply the settings.
EC, E1	Undefined command	The command is not correct.
EC, E2	Failed	Restart the device and redo the procedures. If the problem persists, there may be a problem with the internal circuitry.

- Note: When a string that starts with '@MI,' is received, it is recognized as a command for the AD-8561 and the data is not sent to other channels.
- The communication settings are saved and applied after the AD-8561 is restarted.

Applicable connectors	Setting details		Commands
	◆: Factory settings		
[PRINTER] RS-232C connector (D-sub 9 pin)	Baud rate	2400 bps ◆	@MI024
		4800 bps	@MI048
		9600 bps	@MI096
		14400 bps	@MI144
		19200 bps	@MI192
		28800 bps	@MI288
Data length parity	7 bit, EVEN ◆	@MI7EV	
	7 bit, ODD	@MI7OD	
	8 bit, no parity	@MI8NO	
[BARCODE READER] USB connector (Type A)	HID mode	Key mode ◆ (when searching and registering ID/items with the counting scale)	@MICKM
		Command mode (when sending commands to the counting scale)	@MICCM

7. Troubleshooting

Phenomenon	Possible cause	Action to take
LED does not light blue when power is supplied.	Poor connection of power source	Turn on the power to the counting scale. If the problem persists, switch to an AC adapter for power supply. Check the output rating of AC adapter.
Red LED lights	Internal circuitry error	Restart the device.
LED does not light white or yellow.	Connection error	Check the specifications of the USB device.
When a barcode reader is connected, the device does not work.	Insufficient power supply	Switch to AC adapter for power supply.
Communication fails.	Connection Error	Check the wiring of connector.
	Communication settings	Reconfirm communication settings are different for each channel.
The comparator cannot be input.	Connection error	Check the wiring. The counting scale is not set to comparator output.

8. Specifications and Options

8-1. Specifications

Model	AD-8561-MI02	AD-8561-MI04
Power source	AC adapter (DC 9 V to 12 V / 500 mA or higher)	
Temperature range	-10°C to 40°C (No condensation should be observed)	
Display (LED)	Power on (blue), USB Type A connected (white/yellow), Error (red)	
Power consumption	Approximately 0.2 VA (when USB Type A is not connected)	
Size (W x D x H)	195 x 60 x 40 [mm]	
Weight	Approximately 190 [g]	
Materials	Case: ABS, magnets: ferrite, magnet support hole: iron	
Items included	D-sub 9 pin cable (for connecting the counting scale), instruction manual	
Connectable counting scale	GC series counting scale (refer to the A&D website)	
Connector form	Connector for the counting scale/RS-232C: D-sub 9 pin (male)	
	USB host: Type A	Comparator output: terminal (4-pin)

8-2. Related Software

- The following software can be downloaded from the A&D website (<https://www.aandd.co.jp/>).
- WinCT (data processing software for balances and scales)
 - Support > Software > WinCT.
 - USB driver for AD-8561-MI02 USB Function
 - From the products page on the A&D website.

8-3. Optional Devices

- AC adapter
 - Check for the latest adapter in the products page on the A&D website.
- D-sub 9 pin cable for connecting the counting scale
 - Same cable as the accessory
 - 1m: AX-KO2741-100
 - * If a longer cable is required, a 2-m/5-m cable listed in (3) is usable. However, when a cable listed in (3) is used, power cannot be supplied from the counting scale. A separate AC adapter should be connected for power supply.

- D-sub 9 pin cable for RS-232C
 - 2m: AX-KO2466-200
 - 5m: AX-KO2466-500
 - * If a 1-m cable is sufficient, the cable mentioned in (2) is usable.
- Discrete wire cable for connecting a terminal block
 - 2m: AX-KO8561-N200
- USB cable for the AD-8561-MI02 USB function (micro B - Type A)
 - 1.2m: AX-TB-AMB2A12BK
- GC-14 (mounting hardware exclusively for GC series counting scales)

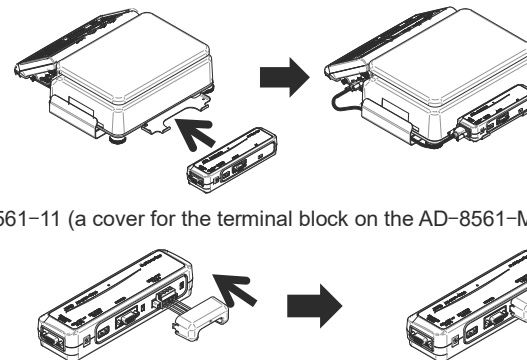

(7) AD8561-11 (a cover for the terminal block on the AD-8561-MI04)

A&D Company, Limited

3-23-14 Higashi-Ikebukuro, Toshima-ku, Tokyo 170-0013, JAPAN
Telephone: [81] (3) 5391-6132 Fax: [81] (3) 5391-1566

A&D ENGINEERING, INC.
4622 Runway Boulevard Ann Arbor, Michigan 48108, U.S.A.
Telephone: [1] (800) 726-3364

A&D INSTRUMENTS LIMITED
Unit 24/26 Blacklands Way, Abingdon Business Park, Abingdon, Oxfordshire OX14 1DY United Kingdom
Telephone: [44] (1235) 550420 Fax: [44] (1235) 550485

A&D AUSTRALASIA PTY LTD
32 Dew Street, Thebarton, South Australia 5031, AUSTRALIA
Telephone: [61] (8) 8301-8100 Fax: [61] (8) 8352-7409

A&D KOREA Limited 한국에이.엔.디(주)
서울특별시 영등포구 국제금융로6길33 (여의도동) 맨하탄빌딩 817 우편 번호 07331 (817, Manhattan Bldg., 33. Gukjegeumyung-ro 6-gil, Yeongdeungpo-gu, Seoul, 07331 Korea)
전화: [82] (2) 780-4101 팩스: [82] (2) 782-4264

ООО А&D RUS ООО "Эй энд Ди Рус"
Почтовый адрес: 121357, Российская Федерация, г. Москва, ул. Вереysкая, дом 17
Юридический адрес: 117545, Российская Федерация, г. Москва, ул. Дорожная, д.3, корп.6, комн. 86
(121357, Russian Federation, Moscow, Vereyskaya Street 17)
тел.: [7] (495) 937-33-44 факс: [7] (495) 937-55-66

A&D Instruments India Private Limited ऐ&डी इन्स्ट्रूमेन्ट्स इण्डिया प्राो लिमिटेड
509, उद्योग विहार, फेस -5, गुडगांव - 122016, हरियाणा, भारत
(509, Udyog Vihar, Phase-V, Gurgaon - 122016, Haryana, India)
फोन : [91] (124) 4715555 फैक्स : [91] (124) 4715599

A&D SCIENTECH TAIWAN LIMITED. A&D台灣分公司 艾安得股份有限公司
台灣台北市中正區青島東路5號4樓
(4F No.5 Ching Tao East Road, Taipei Taiwan R.O.C.)
Tel : [886](02) 2322-4722 Fax : [886](02) 2392-1794

A&D INSTRUMENTS (THAILAND) LIMITED บริษัท เอ แอนด์ ดี อินสตรูमेंท์ (ไทยแลนด์) จำกัด
168/16 หมู่ที่ 1 ตำบลศรีสวัสดิ์ อำเภออรัญชัย จังหวัดปทุมธานี 12110 ประเทศไทย
(168/16 Moo 1, Rangsit, Thanyaburi, Pathumthani 12110 Thailand)
Tel : [66] 20038911