

AD-4212C-300
AD-4212C-600
AD-4212C-3000
AD-4212C-6000
AD-4212C-301
AD-4212C-3100

Production Weighing Unit

INSTRUCTION MANUAL



A&D Company, Ltd.

1WMPD4001992I

© 2016 A&D Company, Limited. All rights reserved.

No part of this publication may be reproduced, transmitted, transcribed, or translated into any language in any form by any means without the written permission of A&D Company, Limited.

The contents of this manual and the specifications of the instrument covered by this manual are subject to change for improvement without notice.

Windows and Excel are registered trademarks of Microsoft Corporation.

Contents

1. Introduction	4
1.1. Features	4
1.2. Compliance.....	7
2. Unpacking the Balance.....	8
2.1. Unpacking.....	8
2.2. Installing the Balance	10
3. Precautions.....	12
3.1. About dustproof / waterproof performance.....	12
3.2. Before Use.....	12
3.3. When Building Into a System	13
3.4. During Use.....	17
3.5. After Use.....	17
3.6. Power Supply	17
4. Operation of WinCT-AD4212C.....	18
4.1. Changing the Weighing Speed Using WinCT-AD4212C	19
4.2. Sensitivity Adjustment.....	19
4.3. Changing the Baud Rate Using WinCT-AD4212C	21
5. Smart Range Function	22
6. Communication Specifications.....	23
7. Maintenance	31
8. Troubleshooting	32
8.1. Checking the Balance Performance and Environment	32
8.2. Asking For Repair.....	33
9. Specifications	34
10. External Dimensions.....	36
11. Options.....	37
12. Terms.....	39

1. Introduction

This manual describes how the AD-4212C series balance works and how to get the most out of it in terms of performance.

Read this manual thoroughly before using the balance and keep it at hand for future reference.

1.1. Features

- A Weighing Unit, suitable for building into a production line system. The weighing unit is compact, with a width of 59 mm.
- A Super Hybrid Sensor (SHS) is used to provide high resolution and high response speed.

Model	Weighing capacity	Readability	Stabilization time*1
AD-4212C-300	320 g	0.001 g	0.5 second (0 - 30 g), 1.0 second (30 - 320 g)
AD-4212C-600	620 g	0.001 g	0.5 second (0 - 30 g), 1.0 second (30 - 620 g)
AD-4212C-3000	3200 g	0.01 g	0.5 second (0 - 300 g), 1.0 second (300 - 3200 g)
AD-4212C-6000	6200 g	0.01 g	0.5 second (0 - 300 g), 1.0 second (300 - 6200 g)
AD-4212C-301	51 g*2	0.0001 g	1.3 seconds
	320 g	0.001 g	1.0 second
AD-4212C-3100	510 g*2	0.001 g	1.3 seconds
	3200 g	0.01 g	1.0 second

*1 With **FAST** selected under good environment

*2 Smart range (Refer to "5. Smart Range Function".)

- The AD-4212C series can output the weighing digital data directly. Therefore, the AD-4212C series (the weighing unit) can be connected to a personal computer or a PLC directly.
- Dust-protected and Protected Against Splashing Water (Complying with IP65). The AD-4212C series has a patented shock absorber under the weighing pan and can cope with movement in all directions, protecting the weighing unit from an actuator malfunction.
- Windows Communication Tools (WinCT-AD4212C), allows easy confirming of the weighing data by using a Windows-based personal computer.
Windows is a registered trademark of the Microsoft Corporation.
- When connected to an optional remote controller, an AD-8922A, AD-8923-BCD or AD-8923-CC, the remote controller can receive the weighing data and manually perform re-zero and sensitivity adjustment.
The AD-8922A can output the data using BCD, comparator or analog out by selection of the option installed in the AD-8922A.
The AD-8923-BCD outputs the data using BCD and the AD-8923-CC outputs the data using CC-Link.
Note: CC-Link is a high-speed field network able to simultaneously handle both control and information data.
- When connected to an optional AD-8526 Ethernet converter, it can convert the AD-4212C RS-232C data, for output to a local area network (LAN).

Example 1 (Connecting to a personal computer or an AD-8922A)

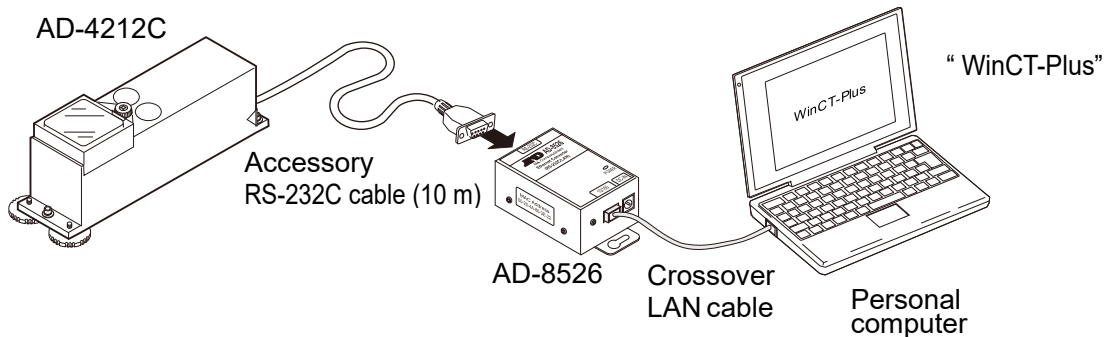
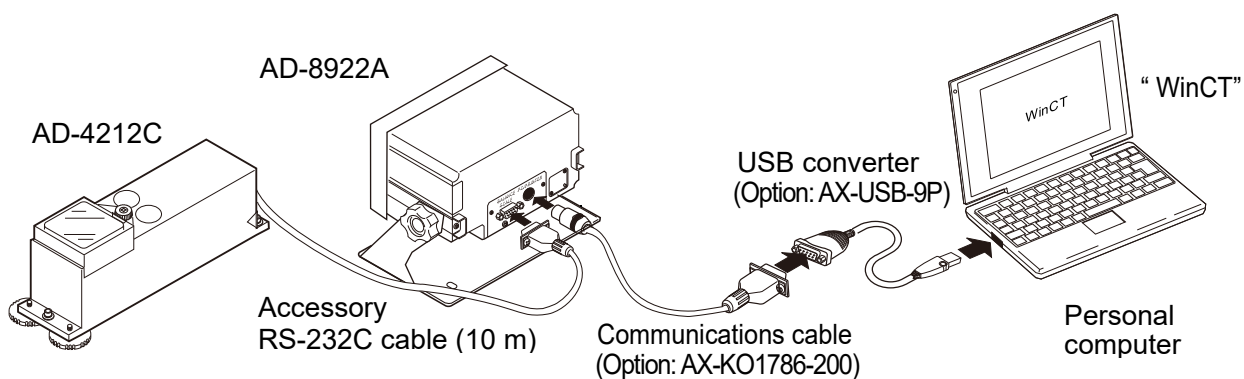
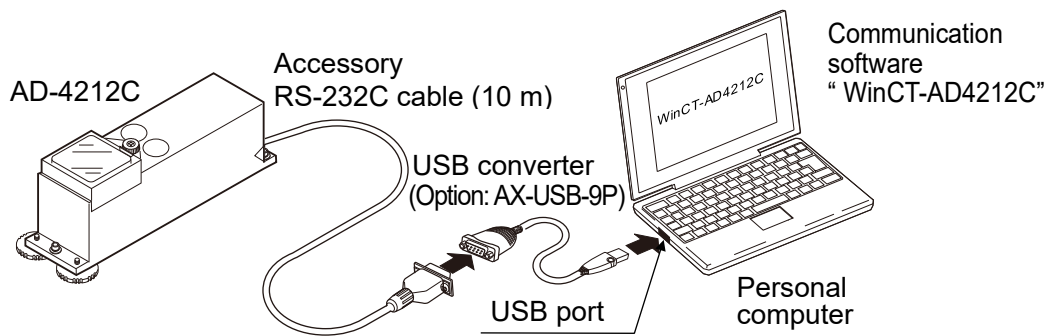

Example 2 (Connecting to a PLC)

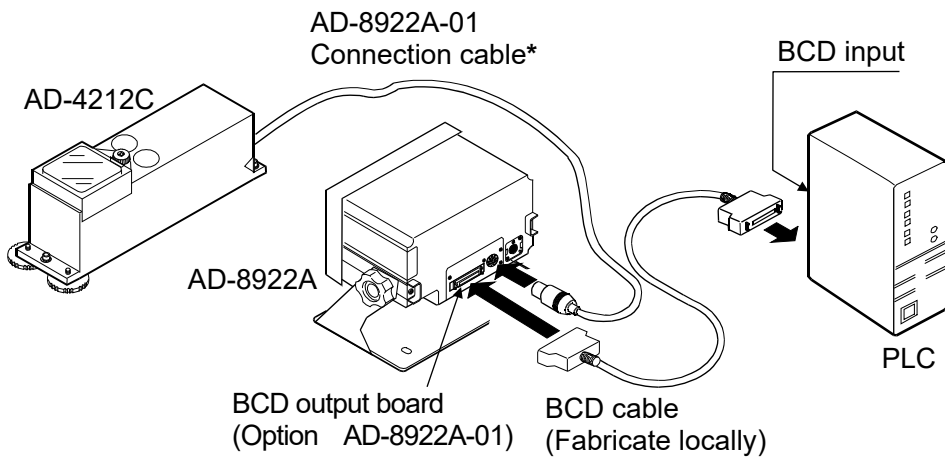
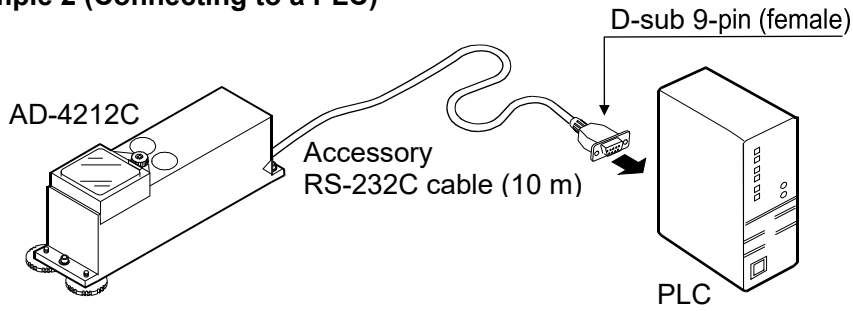

* Specify the AD-8922A-01 connection cable when ordering the AD-8922A-01.

AX-KO3705-200	2 m
AX-KO3705-500	5 m
AX-KO3705-1000	10 m

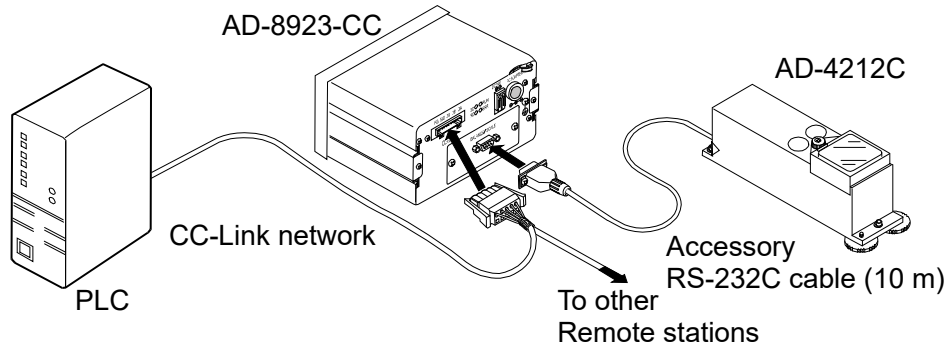

1.2. Compliance

Compliance with FCC Rules

Please note that this equipment generates, uses and can radiate radio frequency energy. This equipment has been tested and has been found to comply with the limits of Class A digital devices pursuant to Part 15 of FCC rules. These rules are designed to provide reasonable protection against interference when equipment is operated in a commercial environment. If this unit is operated in a residential area, it may cause some interference and under these circumstances the user would be required to take, at his own expense, whatever measures are necessary to eliminate the interference. (FCC = Federal Communications Commission in the U.S.A.)

2. Unpacking the Balance

2.1. Unpacking

- The balance is a precision instrument. Unpack the balance carefully. Keep the packing material to be used for transporting the balance in the future.
- When unpacking, see the illustration below to confirm that everything is included.

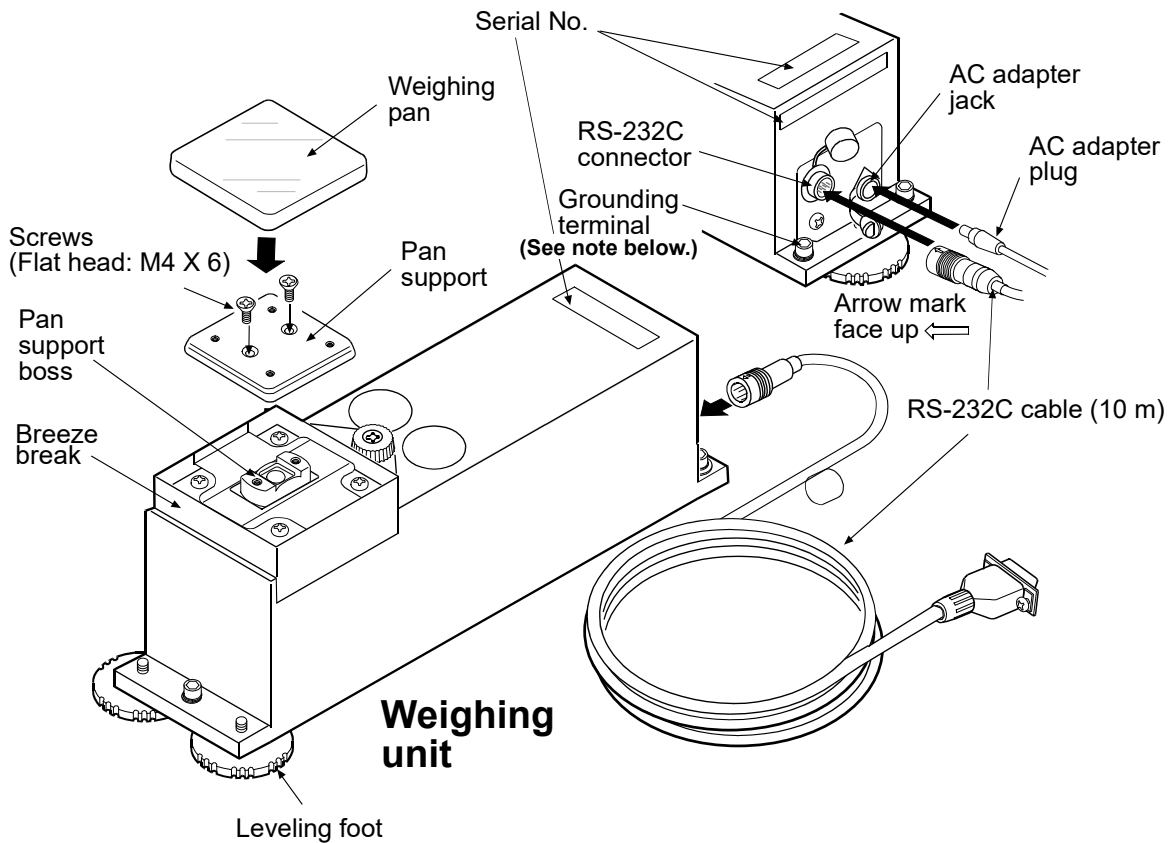

Accessories

AC adapter *1

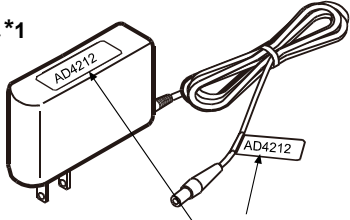

AC adapter ID label

- RS-232C cable (10 m)*2
- Weighing pan
- Pan support
- Screws (Flat head: M4 X 6)

*1 Please confirm that the AC adapter type is correct for your local voltage and receptacle type.

*2 2-m and 5-m cables are available as options. Refer to "11. Options".

Class F1 Calibration weight
(Accuracy : Class E2) 200 g

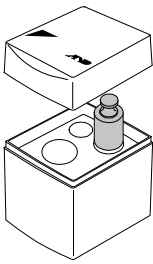

Identification labels
Attach to the AC adapter,
cable, etc.

AD4212	AD4212
AD4212	AD4212

AC adapter labels

Note

- When the AD-4212C series weighing unit is incorporated into a system, be sure to earth ground the weighing unit using the grounding terminal.

Caution

- Use the specified dedicated AC adapter for the balance.
- Use the included AC adapter, and do not connect an AC adapter that is not compatible.
- If using the wrong AC adapter, the balance and other equipment may not work properly.

Attaching the AD-4212C series weighing unit directly on the mounting base

When the AD-4212C series weighing unit is built into a system, remove the three leveling feet and use the screw holes to secure the weighing unit to the base.

Attachment Procedure

1. Remove the three leveling feet.

Caution

Do not remove any other screws from the bottom of the weighing unit. Doing so could damage the weighing sensor.

2. Secure the weighing unit from above. (Prepare appropriate screws with a size corresponding to an M5 screw. The screw hole diameter: 6 mm).

In case of securing the weighing unit from the under side, use M6 screws with 1-mm pitch.

Notes

- **The screws to secure the weighing unit to the mounting base are not provided.**
- **For the position of the holes, refer to “10. External Dimensions”.**

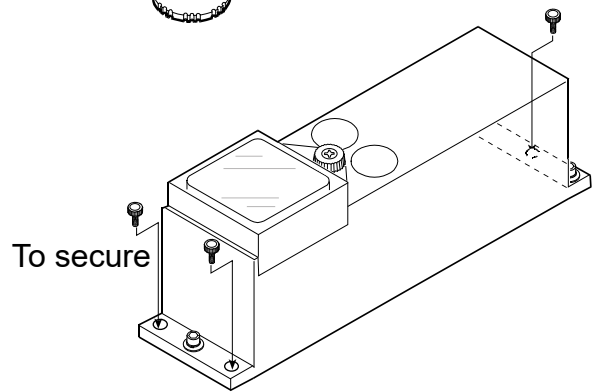
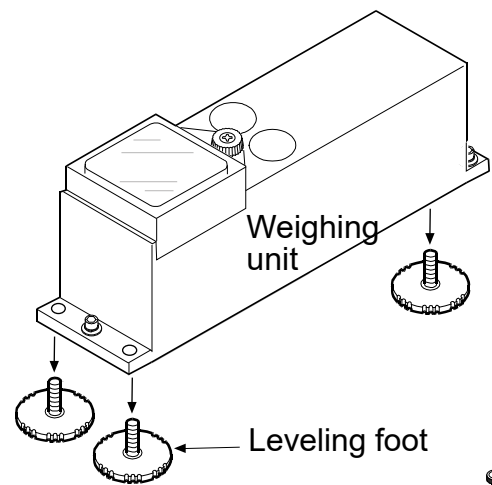

When the leveling adjustment is difficult to perform due to the installation conditions, place a shim between the lower surface of the weighing unit and the securing surface, or use two nuts. If the adjustment is still difficult to perform, perform sensitivity adjustment before use. Then, the balance will function normally.

2.2. Installing the Balance

Install the balance as follows:

1. Refer to "3. Precautions" for installing the balance.
2. Refer to "2.1. Unpacking", to attach the pan support and the weighing pan on the weighing unit.
3. Insert the RS-232C cable into the jack located on the rear of the weighing unit.

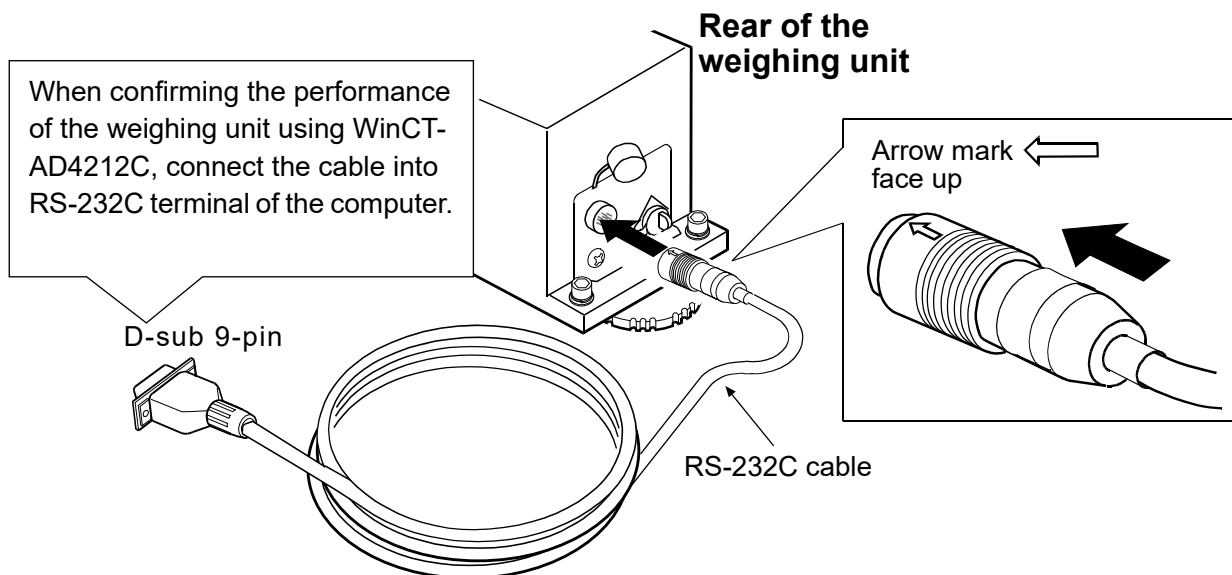

How to disconnect the cable from the weighing unit

Slide the connector sleeve in the direction of the arrow to unlock and gently pull the connector out.

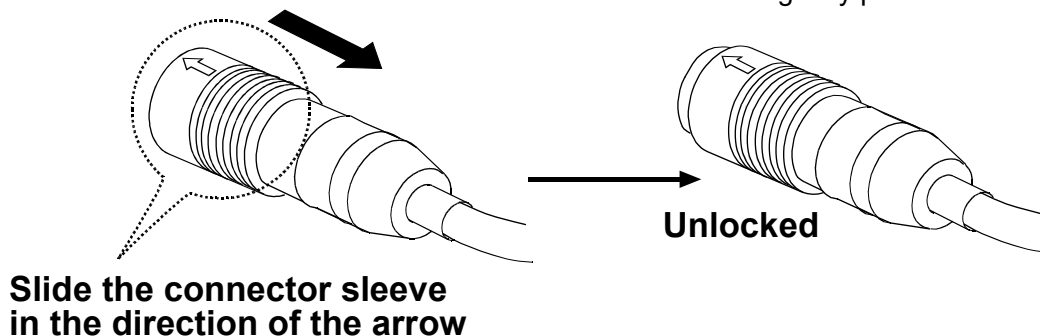

4. Confirm that the AC adapter type is correct for the local voltage and power receptacle type.
5. Plug the AC adapter plug into the AC adapter jack located on the rear of the weighing unit and plug the AC adapter into the electrical outlet. Warm up the balance for 30 minutes or more with nothing on the weighing pan.
6. Set the pan unit and I/O unit to adapt to the peripheral system. Set the following for the I/O unit.
 - RS-232C (Refer to "6. Communication Specifications")
Set the weighing speed to adapt to the ambient conditions.

Note

- **Make sure that the personal computer is in operation before connecting to the AD-4212C.**
7. After the balance has been installed, adjust the sensitivity of the balance using the 200 g calibration weight provided with the balance. For details, refer to "4.2. Sensitivity Adjustment".
(The AD-4212C-3000/6000/3100 can be adjust the sensitivity of the balance using the 200 g weight.)
 8. By removing the provided weighing pan, a locally fabricated weighing pan can be attached to the AD-4212C series by using the four screw holes (M4 screw x pitch 0.7 mm, screw length 6mm or less) on the pan support.

Mass of the locally fabricated weighing pan

Design the weighing pan so that the mass falls within the ranges shown in the table below:

Model	Status	Mass of the weighing pan (g)
AD-4212C-300/301	Pan support is used (with weighing pan removed)	20 to 130
	Pan support boss is used (with the weighing pan and pan support removed)	70 to 180
AD-4212C-600	Pan support is used (with weighing pan removed)	20 to 410
	Pan support boss is used (with the weighing pan and pan support removed)	70 to 460
AD-4212C-3000/3100	Pan support is used (with weighing pan removed)	20 to 3010
	Pan support boss is used (with the weighing pan and pan support removed)	70 to 3060
AD-4212C-6000	Pan support is used (with weighing pan removed)	20 to 6010
	Pan support boss is used (with the weighing pan and pan support removed)	70 to 6060

AD-4212C-300/301

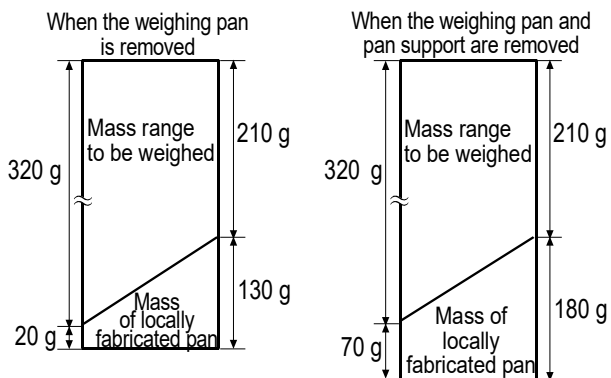

AD-4212C-600

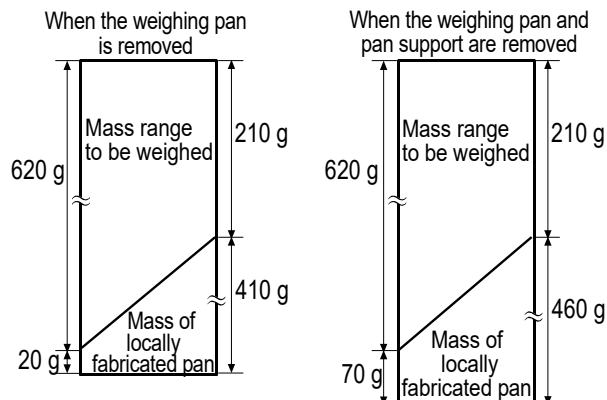

AD-4212C-3000/3100

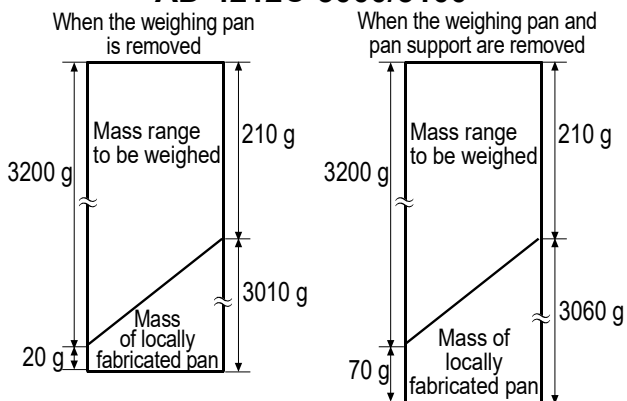

AD-4212C-6000

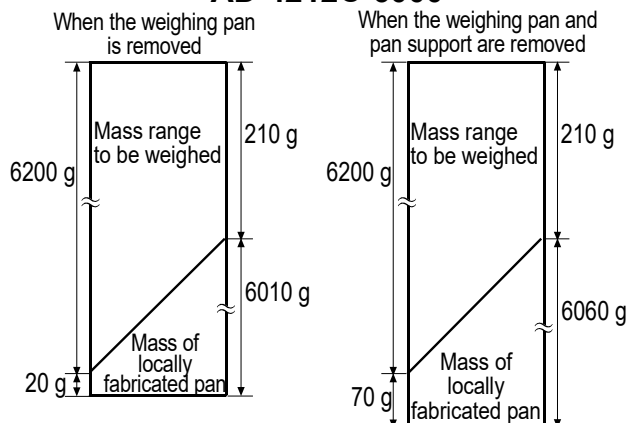

Notes

- If the balance is to be used in a range other than shown above, contact the local A&D dealer.
- To avoid the effects of static electricity or magnetism, use materials other than resin or magnetic materials when designing a weighing pan.
- When a locally fabricated weighing pan is used, the zero point may be shifted greatly right after the AC adapter is plugged in. Perform re-zero before weighing to cancel the amount of zero drift as necessary.

3. Precautions

To get the optimum performance from the balance and acquire accurate weighing data, note the following:

3.1. About dustproof / waterproof performance

- The dustproof / waterproof level IP65 of the balance means "not affected by direct jets of water". Washing with strong water pressure, submersion in water, etc. may cause water to enter the balance and cause a malfunction.
- When installing the balance in a dustproof / waterproof environment, make sure that the AC adapter plug is firmly inserted into the AC adapter input jack and that the RS-232C output cable is attached.
- When not using the AC adapter or RS-232C output cable, attach the rubber caps affixed to the packing rings.

Rear of the weighing unit

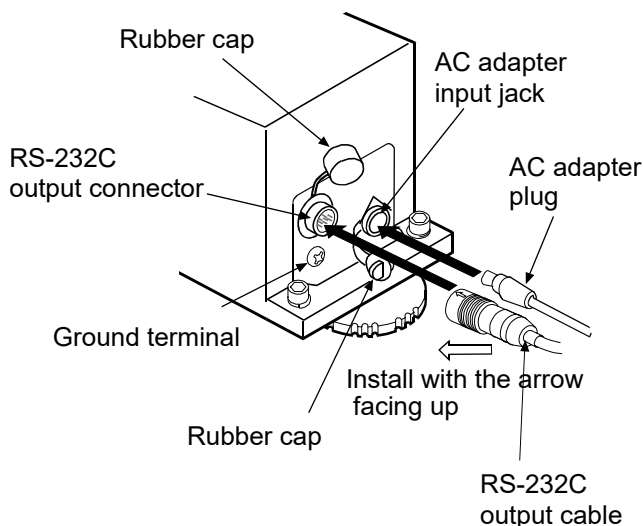

3.2. Before Use

- Install the weighing unit in an environment where the temperature and humidity are not excessive. The best operating temperature is about 20°C / 68°F at about 50% relative humidity.
- Install the weighing unit where it is not exposed to direct sunlight and it is not affected by heaters or air conditioners.
- Install the weighing unit where it is free of dust.
- Install the weighing unit away from equipment which produces magnetic fields.
- Install the weighing unit in a stable place avoiding vibration and shock. Corners of rooms on the first floor are best, as they are less prone to vibration.
- Ensure a stable power source when using the AC adapter.
- Plug in the AC adapter as usual, and warm up the balance for 30 minutes or more.
- Adjust the sensitivity of the balance before use or after having moved it to another location. In addition, adjust the sensitivity of it periodically to maintain the accuracy.

Caution

Do not install the balance where flammable or corrosive gas is present.

3.3. When Building Into a System

The AD-4212C is a precision balance. When it is built into a system, errors such as unstable weight values may occur due to static electricity, vibration, sample temperature and magnetism of the materials weighed or used for the devices near the balance.

When using the balance as part of a system, take the following precautions:

- **Precautions when not performing the weighing at the center of the weighing pan**

If not performing the weighing at the center of the weighing pan, design the weighing system so that the total moment of the support device and the object to be weighed will be the value specified in the table below. Even a load, with a moment of less than the specified value, when applied to the balance, may cause the overload protection mechanism to function slowly, to tilt the weighing pan.

Allowable eccentric load for each model

Model	Allowable eccentric load
AD-4212C-300/600/301	0.1 Nm or less
AD-4212C-3000/6000/3100	0.3 Nm or less

AD-4212C-300/600/301

Example of a system where the total moment of the device and the object is 0.1 Nm or less:

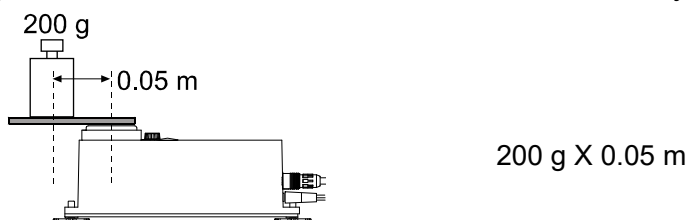

AD-4212C-3000/6000/3100

Example of a system where the total moment of the device and the object is 0.3 Nm or less:

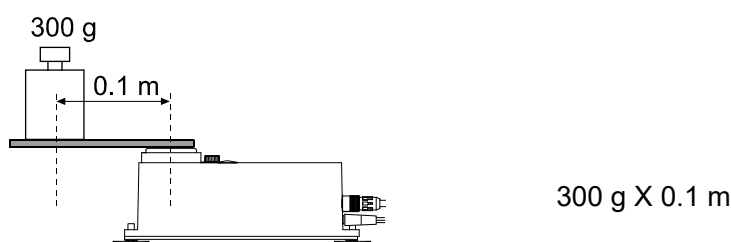

Note: The values above are for reference and may be different from actual specifications.

Although the overload protection mechanism is built in, please avoid giving impact shock to the weighing pan while weighing.

If a heavy weighing material is placed on the weighing pan, it may bend downward slightly. When you make a jig, consider it.

● **Errors due to a static charge and measures to take**

When the ambient humidity is less than 45% RH, insulators such as plastic or glass are prone to static electricity. When charged material comes close to the balance, a pulling force is generated by static induction between the charged material and the weighing pan. This causes an unstable weight value.

To protect the balance against a discharge generated by charged material when it comes close to the balance, be sure to earth ground the weighing unit and the display unit.

Note that static electricity generated by static induction will not be canceled by earth-grounding. Use a humidifier or the AD-1683 DC static eliminator,

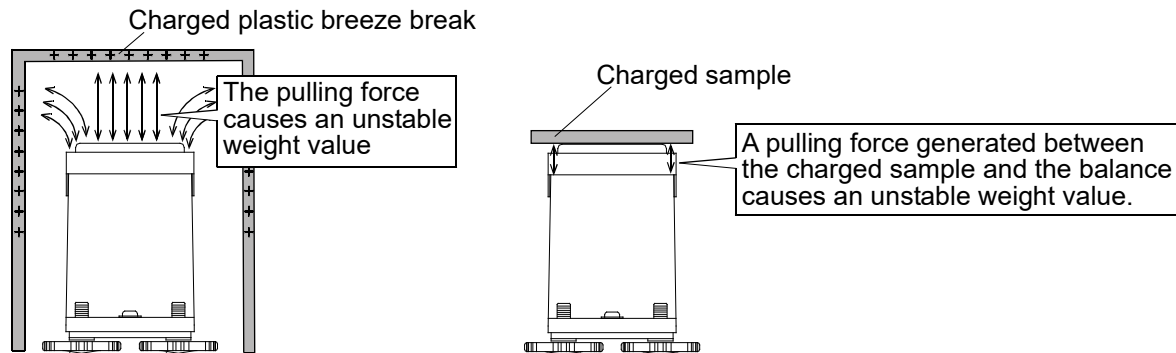

Measures to take (Plastic is used in the examples below. They can be applied to glass, too.)

- When the sample or devices are plastic
 - Use a static eliminator that generates no air blow such as the AD-1683, DC static eliminator, to remove static electricity.
 - Place the sample in a container that is made of a conductive material such as metal and that can be sealed, and then weigh it.
- When the sample is powdery
 - When the balance is used in combination with a feeder for batch weighing of powdery samples, samples may be charged by rubbing sample particles against each other. Use a static eliminator and perform weighing while removing static electricity.
- When the sample container is made of material that is prone to static electricity such as plastic
 - Cover the outside of the container with a metal such as aluminum foil.
 - Apply an anti-static agent onto the container.
- When making a breeze break using plastic
 - Apply an anti-static agent onto the breeze break.
 - Use a conductive acrylic fiber.
- When plastic exists in the balance installation site
 - Cover the plastic with a grounded conductive material.
 - Apply an anti-static agent onto the plastic.
- When an operator is static charged

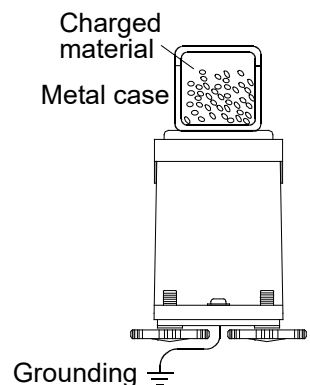

If an operator's clothes are static charged, especially in winter, it may be a cause for unstable weight values.

- Wear an anti-static wrist strap.

● **Errors due to airflow and measures to take**

- Where the influence of ambient airflow is great such as: close to an air conditioner, door or passage way. Even very subtle airflow that is hard to be detected may influence the weighing operation.
 - Avoid those areas as a weighing site.
 - If weighing is to be performed in such an area, use a breeze break or take other appropriate measures.

- Where the influence of heat or drafts is great
 - Eliminate temperature differences between a sample and the environment.
When a sample is warmer (cooler) than the ambient temperature, the sample will be lighter (heavier) than the true weight. This error is due to a rising (falling) draft around the sample.

- Do not touch the sample directly with your hand. Use tweezers or other tools.

If you touch the sample, the same type error described above will occur.

- Do not perform weighing where it is exposed to direct sunlight. Weighing errors may occur due to sudden temperature change or drafts.

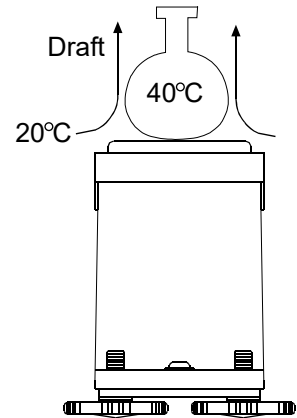

● **Errors due to vibration and measures to take**

- Where the influence of vibration is great, such as:
(1) Soft ground (2) Second or higher floor (3) Near center of a floor far from pillars (4) Seismic isolated structures (5) Near tall buildings.

In the areas listed above, the scale may yield unstable weight values on windy days or after an earthquake. Especially in case of (4) and (5), weight values may be unstable for a long period of time because of long lasting low-frequency vibration after strong winds or an earthquake.

- **Errors due to moving the weighing unit**

- The performance of this device is guaranteed when it is not moving.
When incorporating the weighing unit into a system that moves the main body, pay sufficient attention to the following and perform a thorough preliminary check.
 - If moving the weighing unit, it may be damaged by impact.
Also, the measured value will not be stable immediately after moving.
Avoid sudden movement, stopping, and impact, and provide a sufficient waiting time for the measurement value to stabilize when acquiring measurement data.
 - The moving device should have a structure where the weighing unit can be kept level.
 - In order to avoid the influence of vibration, the moving table should have a structure that is less susceptible to vibration, such as reducing the play of moving parts.

- **Errors due to other causes and measures to take**

- Change in temperature or humidity
A sudden change in temperature or humidity can generate a draft and cause the balance to absorb or exude moisture, which leads to unstable displays.
 - Avoid sudden change in temperature or humidity.
 - Use an air conditioner or humidifier to control the temperature or humidity.
- Magnetic material
The balance uses a strong magnet as part of the balance assembly, so use much care when weighing magnetic materials.
 - Place a non-magnetic object such as aluminum or brass between the sample and the balance to keep an appropriate distance between them while weighing.

3.4. During Use

- To minimize the affect by electrical noises, earth ground the weighing unit and the display unit (option).
- Do not drop things upon the weighing pan, or place a sample on the pan that is beyond the balance weighing capacity. Place a sample in the center of the weighing pan to minimize corner-load errors.
- To prevent possible errors, before each weighing, perform re-zero using the RS-232C command, or calculate the difference between the weight value before and after weighing.
- Take into consideration the affect of air buoyancy on a sample when measuring the absolute value with the Readability of 0.1 mg.
- Even though the scale is dust-protected and protected against splashing water, complying with IP65, be sure to clean the weighing pan and keep the conditions around the pan clean after weighing powdery, fluid samples or metallic strips.

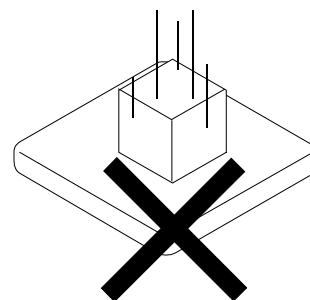

3.5. After Use

- Avoid mechanical shock to the weighing unit.
- Periodically adjust the sensitivity of the balance, using a calibration weight.
- Do not disassemble the weighing unit. Contact the local A&D dealer if the balance needs service or repair.
- Do not use organic solvents to clean the weighing unit. Clean the weighing unit with a lint free cloth that is moistened with warm water and a mild detergent.
- Avoid dust and water so that the weighing unit weighs correctly. Protect the internal parts from liquid spills and excessive dust.

3.6. Power Supply

- When the AC adapter is connected, the balance is in the standby mode if the standby indicator is on (refer to “[4. Operation of WinCT-AD4212C](#)”). This is a normal state and does not harm the balance. For accurate weighing, plug in the AC adapter and warm up the balance for the appropriate duration before use.

4. Operation of WinCT-AD4212C

The software has the following functions:

- Set the weighing speed
- Set the readability value
- Sensitivity Adjustment
- Set the baud rate
 - The parameters set using these functions, are stored in non-volatile memory, and maintained, even if the AC adapter is removed.
- A data logging function, allows confirmation of the weighing data after weighing

Before use

Download the software from the A&D website noted below.

Software download:

<https://www.aandd.jp/products/software/software.html>

(This URL is subject to change. If it has changed, please access Support from <https://www.aandd.jp/>)

1. Install WinCT-AD4212C on the computer. For details, refer to Readme of WinCT-AD4212C.
2. Connect one end of the RS-232C cable to the weighing unit RS-232C connector and connect the other end of the RS-232C cable (D-sub 9-pin) to the personal computer RS-232C terminal.
3. Set the COM port of WinCT-AD4212C on the personal computer, and then press the **START** button. The personal computer will display the weight value.

Function of display symbols and buttons

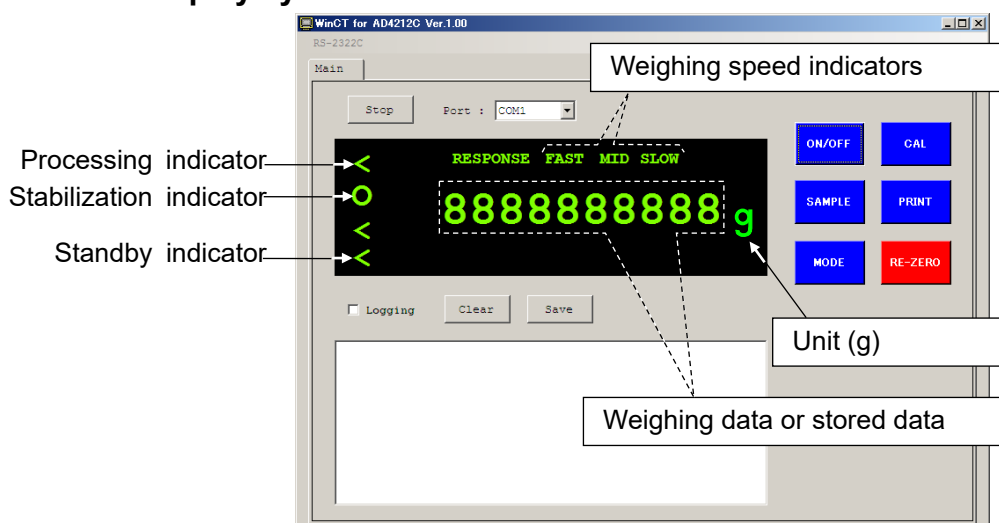

Button	When pressed
ON/OFF	Switches between the weighing mode and the standby mode. With the standby mode, only the standby indicator is displayed. The ON/OFF button is available anytime. Therefore, if you press the ON/OFF button when operating, the balance switches to the standby mode.
SAMPLE	In the weighing mode, switches the Readability.
MODE	Changes the weighing speed.
CAL	Enters the sensitivity adjustment mode.
PRINT	(Usually no function. Used in the sensitivity adjustment mode.)
RE-ZERO	Sets the display to zero.

4.1. Changing the Weighing Speed Using WinCT-AD4212C

The weighing speed can be selected from the following three rates to minimize the influence on weighing that is caused by drafts and/or vibration at the place where the balance is installed.

Indicator	Speed	Stability
FAST	Fast	Sensitive value
MID.	↑	↓
SLOW	Slow	Stable value



Operation

1. Press the **MODE** button.

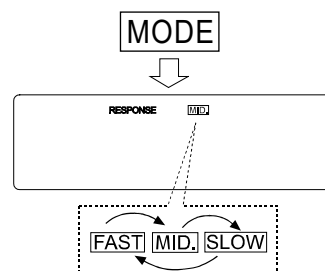

2. Press the **MODE** button to select a weighing speed.
Either **FAST**, **MID.** or **SLOW** can be selected.

MODE Each pressing switches the indicators

4.2. Sensitivity Adjustment

Sensitivity adjustment

Adjust the sensitivity of the balance using a calibration weight.

Sensitivity adjustment is possible without removing the special plate or jig attached to the measuring plate.

(However, the total of the special plate and jig and the calibration weight used must not exceed the capacity of the balance.)

Caution

- Do not allow vibration or drafts to affect the balance during sensitivity adjustment.

Caution on using an external calibration weight

- The accuracy of the weight can influence the accuracy of weighing. Select an appropriate weight as listed below. A calibration weight (conforming to OIML, Class E2 or equivalent) is provided with the balance as a standard accessory.

Model	Usable calibration weight	Calibration weight provided
AD-4212C-300	50g, 100g, 200 g , 300g	200 g
AD-4212C-600	50g, 100g, 200 g , 300g, 400 g, 500 g, 600 g	
AD-4212C-3000	50g, 100g, 200 g , 300g, 500 g, 1000 g, 2000g, 3000g	
AD-4212C-6000	200 g , 500 g, 1000 g, 2000g, 3000g, 4000 g, 5000 g, 6000 g	
AD-4212C-301	50g, 100g, 200 g , 300g	
AD-4212C-3100	50g, 100g, 200 g , 300g, 500 g, 1000 g, 2000g, 3000g	

The calibration weight in bold type: factory setting

Display



- This indicator means “the balance is measuring sensitivity adjustment data”. Do not allow vibration or drafts to affect the balance while this indicator is displayed.

Sensitivity adjustment procedure

This function adjust the sensitivity of the balance using the calibration weight.
(Display example: AD-4212C-300)

Operation

1. Plug in the AC adapter and warm up the balance for 30 minutes or more with nothing on the pan.
2. Press the **CAL** button. **CAL 0** is displayed.
 - If you want to cancel sensitivity adjustment, press the **CAL** button. The balance will return to the weighing mode.
 - If you want to change the calibration mass value, press the **SAMPLE** button. Press the **RE-ZERO** button to select the mass value, and press the **PRINT** button to store it. **CAL 0** is displayed.
3. Confirm that there is nothing on the pan and press the **PRINT** button. The balance measures the zero point. Do not allow vibration or drafts to affect the balance. The balance displays the calibration weight value.
4. Place a calibration weight, of the weight value displayed, on the pan and press the **PRINT** button. The balance measures the calibration weight. Do not allow vibration or drafts to affect the balance.
5. The balance displays **End**. Remove the weight from the pan.
6. The balance will automatically return to the weighing mode.
7. Place the calibration weight on the pan and confirm that sensitivity adjustment was performed correctly. If not, check the ambient conditions such as drafts or vibration, and repeat steps 2 through 7.

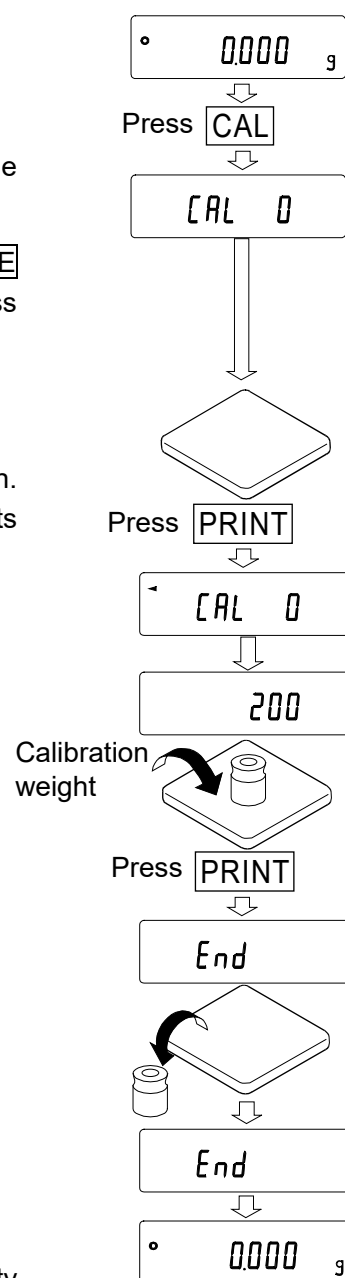

4.3. Changing the Baud Rate Using WinCT-AD4212C

Operation

1. Click the [Settings] tab.
2. Select the baud rate to be used and click the button. (Factory setting: 2400)

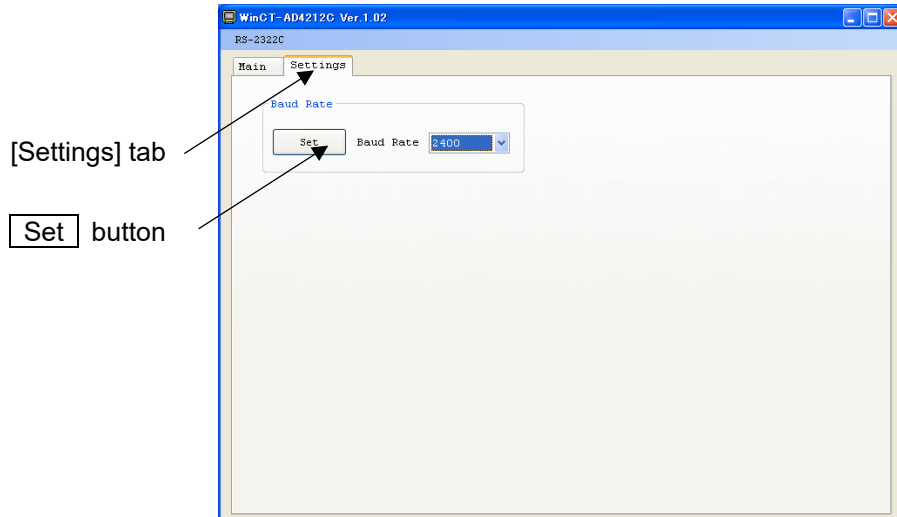

5. Smart Range Function

The AD-4212C-301/3100 are equipped with two ranges. The precision range has a higher resolution. The standard range has a normal resolution.

The range switches automatically, depending on the value displayed. Sending the R command allows weighing in the precision range, regardless of the tare value.

The range can be fixed to the standard range by changing the Readability using the SMP command.

- 1 Send the R command
The balance will start weighing, using the precision range.
- 2 Place a container on the weighing pan.
The weight value exceeds the precision range value and the balance will switch to the standard range.
- 3 Send the R command
The balance will switch to the precision range.
- 4 Place a sample in the container.
The weight value is within the precision range value and the balance will perform a weighing, using the precision range.

Display example: AD-4212C-301

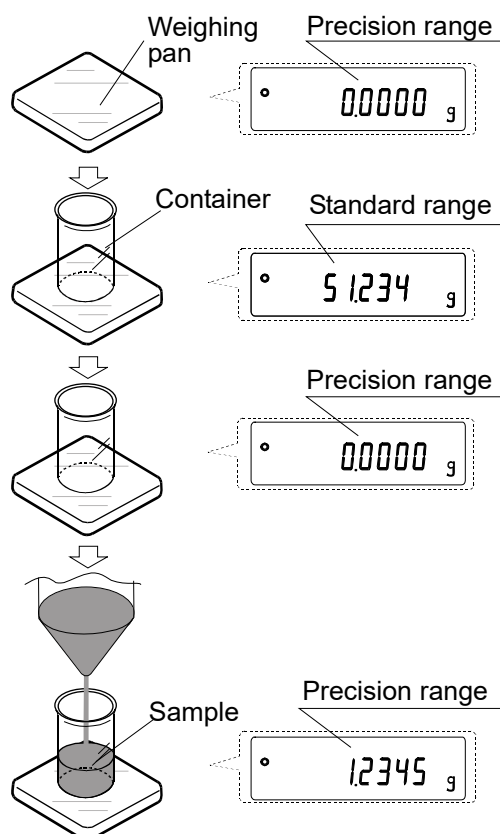

Precision range/standard range

Model	Range used	Weighing range	Readability
AD-4212C-301	Precision range* ¹	0 g to 51 g	0.0001 g
	Standard range	51 g to 320 g	0.001 g
AD-4212C-3100	Precision range* ²	0 g to 510 g	0.001 g
	Standard range	510 g to 3200 g	0.01 g

- The factory setting is the precision range.

*¹ When the weight value exceeds 51 g while the Readability of 0.0001 g (precision range) is used, the balance will switch to the Readability of 0.001 g (standard range). By sending the R command, the balance can weigh from that point up to 51 g, using the Readability of 0.0001 g (precision range).

*² When the weight value exceeds 510 g while the Readability of 0.001 g (precision range) is used, the balance will switch to the Readability of 0.01 g (standard range). By sending the R command, the balance can weigh from that point up to 510 g, using the Readability of 0.001 g (precision range).

6. Communication Specifications

The AD-4212C series can communicate interactively using RS-232C.

The AD-4212C series can continuously transmit the weighing data. (Approx.10 times/second* to 50 times/second)

The AD-4212C series is DCE. The AD-4212C series can connect directly to the RS-232C terminal of a personal computer by using the accessory RS-232C cable.

* Factory setting

1. RS-232C specification

Transmission system	EIA RS-232C	
Transmission form	Asynchronous, bi-directional, half duplex	
Transmission rate	Approx.10 times/second* to 50 times/second	
Data format	Baud rate	2400bps* to 19200bps
	Data bits	7 bits
	Parity	EVEN
	Stop bit	1 bits
	Code	ASCII
	Terminator	<CR><LF>

* Factory setting

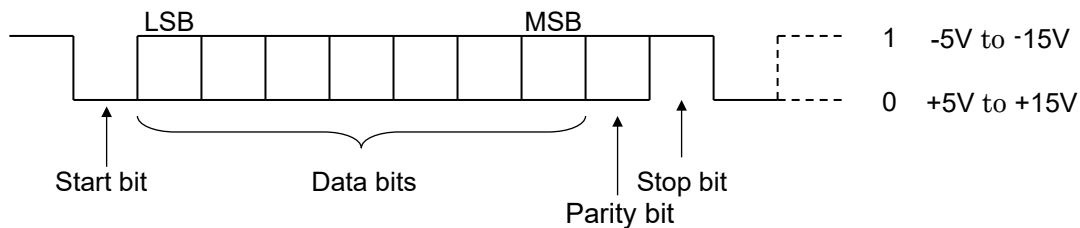

Relation between baud rate and transmission rate of weighing data

Baud rate	Transmission rate of weighing data
2400bps	12.5 times/second
4800bps	25.0 times/second
9600bps	50.0 times/second
19200bps	50.0 times/second

2. Pin position

Pin position of the RS-232C cable (D-Sub 9-pin side, female)

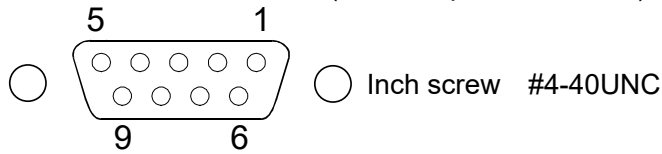

Pin No.	Signal name	Direction	Description
1	(Vs)	-	Internally used* (Power supply GND terminal for external equipment)
2	TXD	Output	Transmit data
3	RXD	Input	Receive data
4	-	-	N.C.
5	SG	-	Signal ground
6	-	-	Internally used*
7	RTS	Input	Request to send
8	CTS	Output	Clear to send
9	(Va)	-	Internally used* (Power supply output terminal for external equipment)

CTS and RTS are internally connected in the balance.

The AD-4212C can communicate by connecting TXD, RXD and SG.

* When connecting to a PLC such as the external equipment, do not connect to the internally used signal line.

3. Data output format

- This format consists of fifteen characters excluding the terminator<CR><LF>.
- A header of two characters indicates the balance condition.
- The polarity sign is placed before the data with the leading zeros. If the data is zero, the plus sign is applied.

Example of output

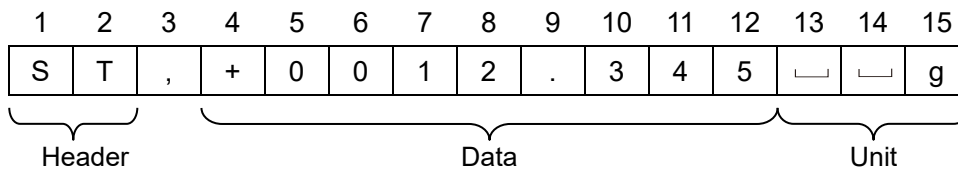

When stable

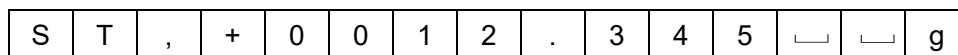

When unstable

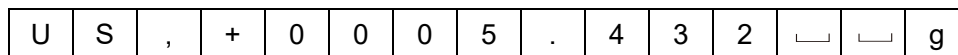

When over state (plus over)

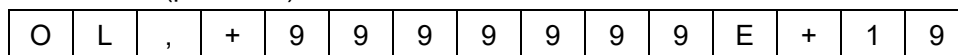

When over state (minus over)

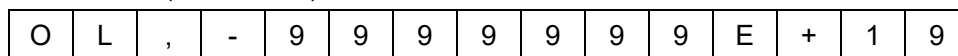

 means "space"

4. Command

The balance can be controlled by the following commands.

When transmitting, add the terminator <CR><LF> to each command.

Commands to query weighing data

When the display is turned on, the AD-4212C series outputs the weighing data continuously.

To use the Q or S command, send the C command to stop the continuous data output, then request the weighing data using the Q or S command.

Command	Description
C	Cancels the SIR command.
Q	Requests the weighing data immediately. (Outputs data regardless of the display condition, stable or unstable. Use this command while the continuous output is stopped.)
S	Requests the weighing data when stabilized. (After the weighing data has stabilized, outputs the data. Use this command while the continuous output is stopped.)
SIR	Requests the weighing data continuously. Starts the continuous output of the weighing data. (The C command stops the continuous output.)

Commands to control the balance

Command	Description
CAL	Enters the sensitivity adjustment mode. *1
OFF	Turns the display off. The weighing unit is in the standby mode.
ON	Turns the display on. The weighing unit is in the weighing mode.
P	Switches between the weighing mode and the standby mode.
PRT	Confirms the sensitivity adjustment value.
R	Sets the display to zero (tare). *2
SMP	Changes the readability.
U	Changes the weighing speed. *1

*1 When changing the weighing speed or in the sensitivity adjustment mode, the balance outputs the control character starting with “@”.

*2 When setting the display to zero, the command waits for the weight value to become stable. When the command waits for the weight value to become stable, the balance stops sending the weighing data.

Example of the R command

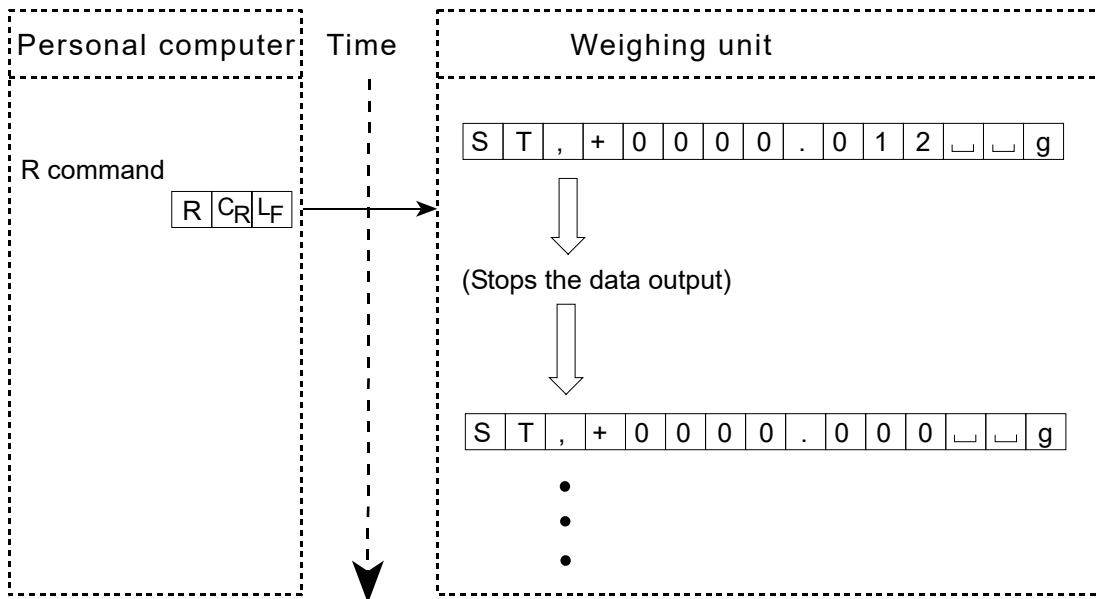

□ means "space"

Example of the CAL command

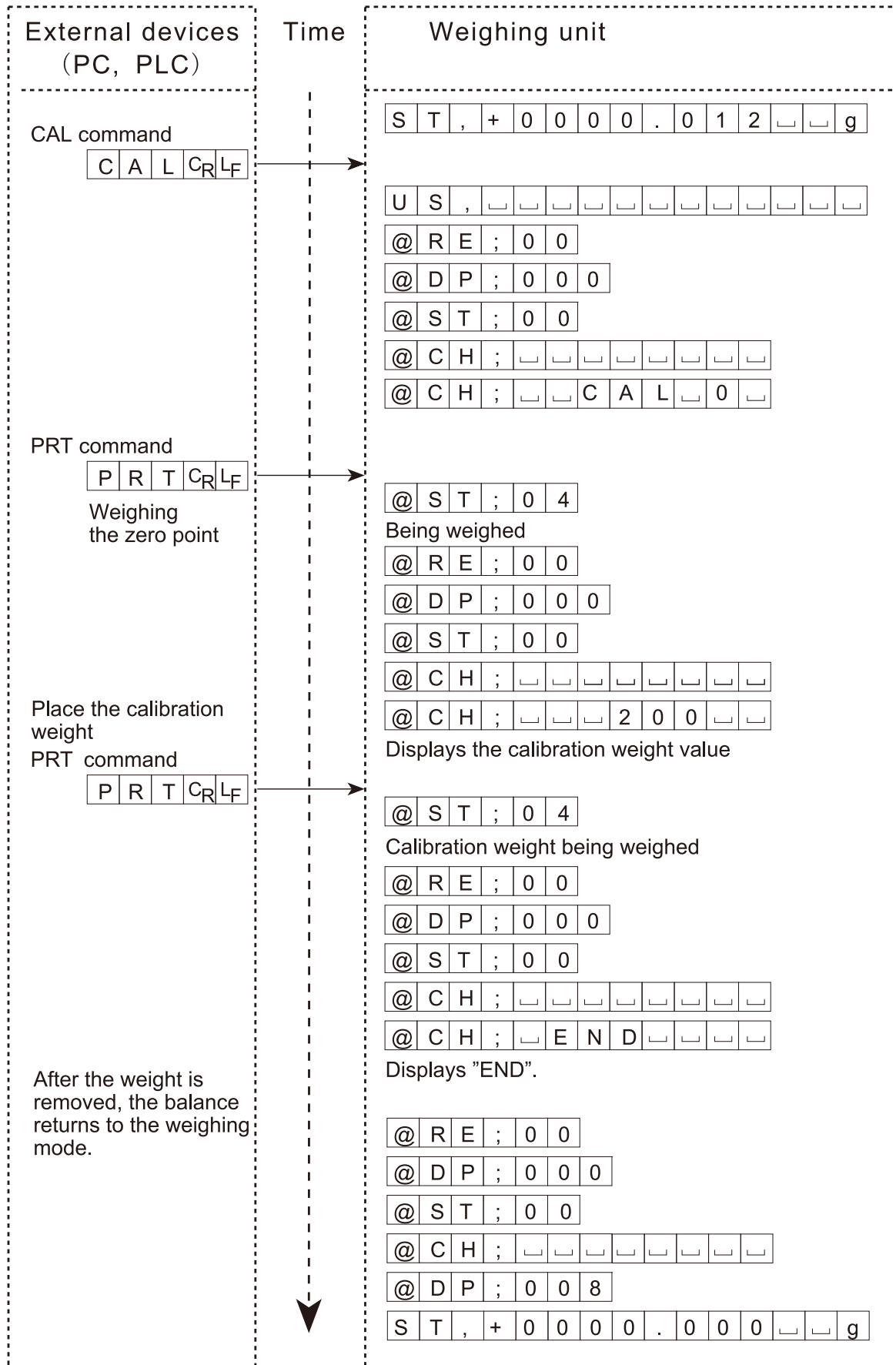

□ means "space"

Example of the SMP command

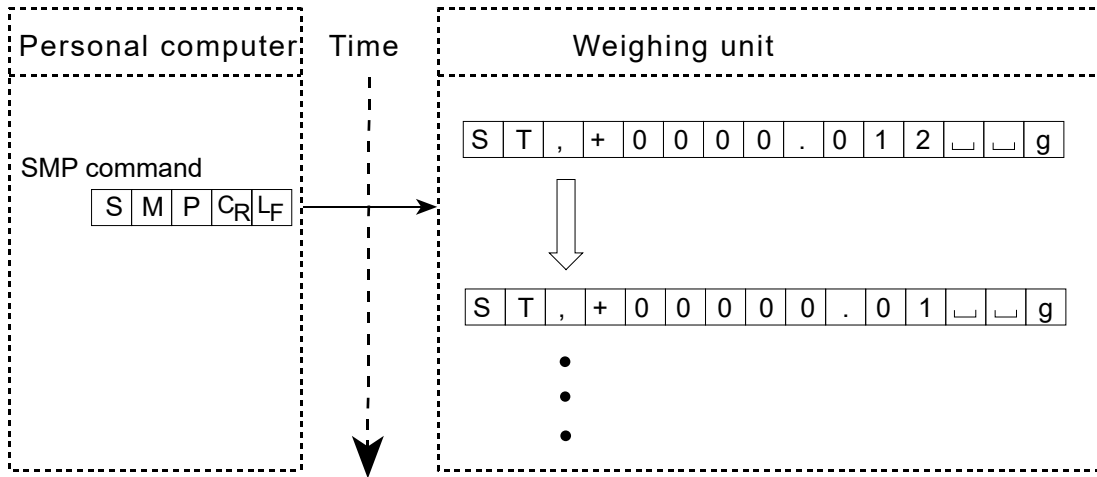

Example of the R command when the precision range is used

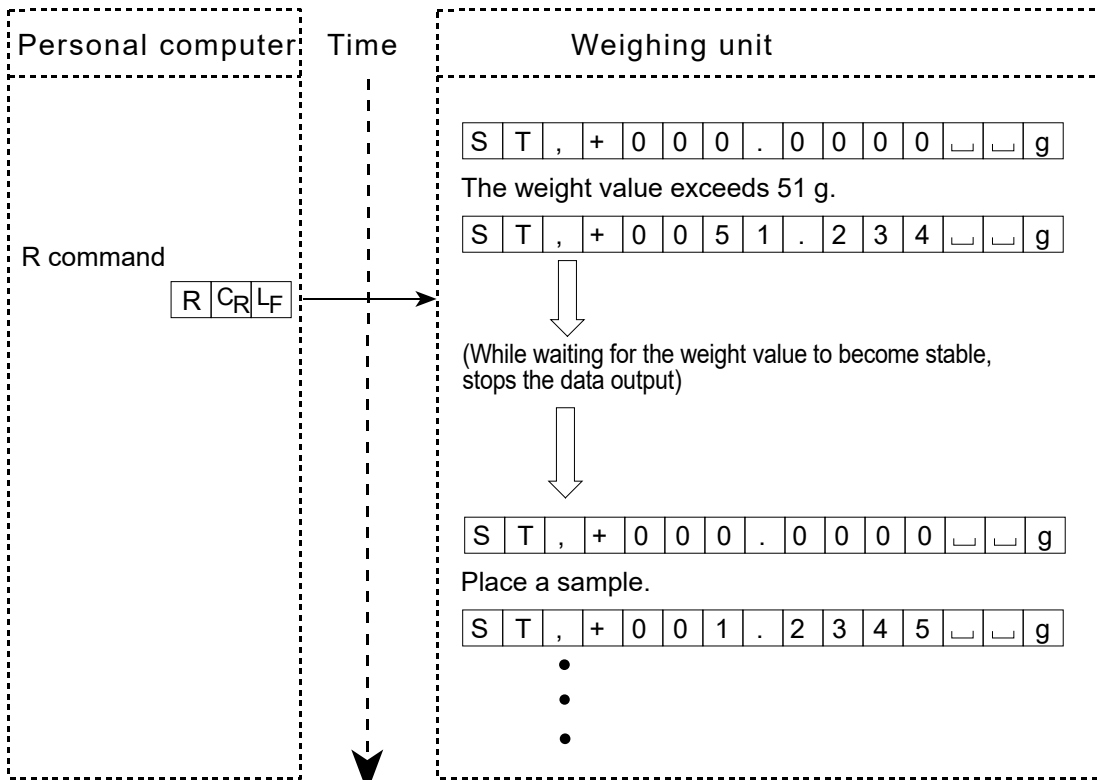

means "space"

S command when old versions of the AD-4212C series balances are used

For AD-4212C balances with a software version 1.40 or earlier, the S command must be enabled using the procedure described below.

For AD-4212C balances with a software version 1.41 or later, the S command is enabled by sending the C command to stop the continuous data output.

Enabling the S command

Download the “WinCT” software on our website, <https://www.aandd.co.jp/>.

Carry out the following procedure using the “RsCom” software in the “WinCT”.

1. Send the C command to stop the continuous data output.

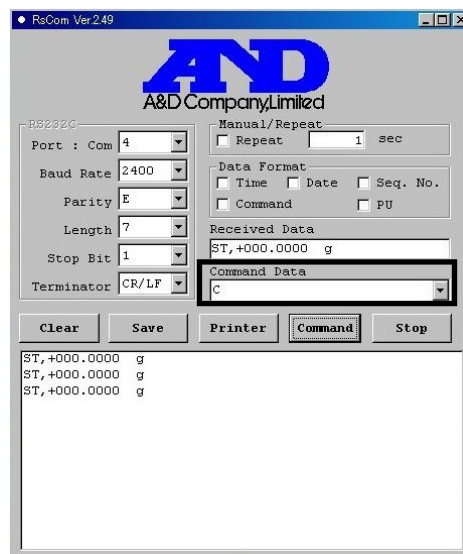

2. Changing the setting

Send the PR:00 command to the balance.

The balance enters the command mode. This enables the S command. This setting is maintained in memory even if the AC adapter is removed.

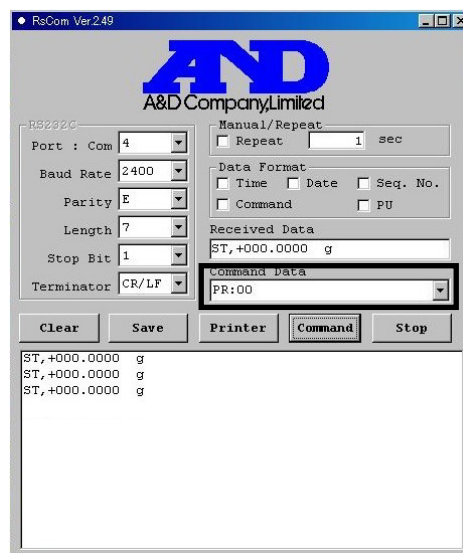

- Confirming whether the PR:00 command has been carried out correctly.
Send the “?PRT” command.
When the response is “Pr,00”, the setting is correct.
Because the setting is in the command mode, the balance does not output the weighing data continuously.

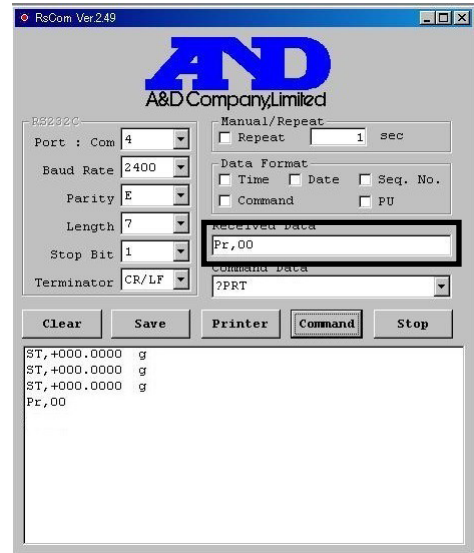

- Returning the setting value to the default value
Send the “PR:03” command to the balance.
The balance enters the continuous output mode.
When the “SIR” command is sent to the balance, the balance outputs the weighing data continuously.

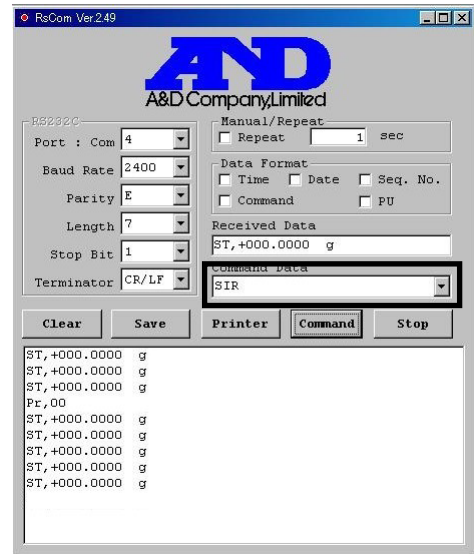
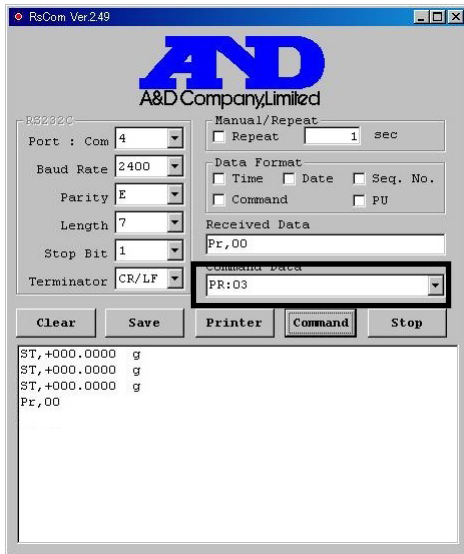

7. Maintenance

- If the balance becomes dirty, wipe it clean with a lint free cloth that is moistened with warm water and a mild detergent.
- Do not use organic solvents or chemical wipes to clean the balance.
- Do not disassemble the balance.
- Use the original packing material for transport.
- The dustproof and waterproof specifications of the AD4212C series indicate waterproof performance in ordinary use, which allows you to wash the weighing pan with water while it is installed.

Note that if the balance is submerged in water or if water pressure is applied to the bottom of the balance body, water may get inside.

- When installing the balance in a dustproof / waterproof environment, make sure that the AC adapter plug is firmly inserted into the AC adapter input jack and that the RS-232C output cable is attached.
- When not using the AC adapter or RS-232C output cable, attach the rubber caps affixed to the packing rings.
- If you wash the balance with hot water, condensation may form inside the balance. Be careful not to allow water vapor to enter inside.

Rear of the weighing unit

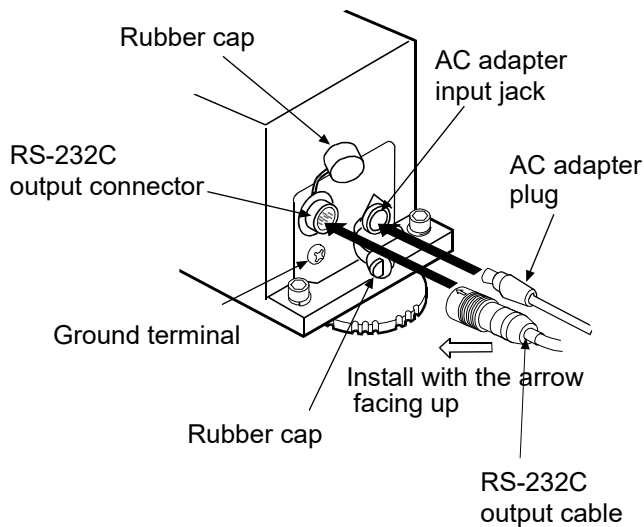

8. Troubleshooting

8.1. Checking the Balance Performance and Environment

The balance is a precision instrument. When the operating environment or the operating method is inadequate, performing accurate weighing will not be possible. If the balance seems to have a problem with repeatability or to perform improperly, check as described below.

Also, visit our website, <https://www.aandd.jp/>, for “Information Library” and “FAQ”.

If improper performance persists, contact the local A&D dealer for repair.

Checking that the balance performs properly

- Check the balance repeatability using the calibration weight. Be sure to place the weight in the center of the weighing pan. Pay attention to the airflow. Use the breeze break, or cover the balance if necessary.
- Check the balance repeatability, linearity and weighing value using external weights with a known value.
- When the balance is built into a system, remove the balance from the system. Place it on a solid table and perform checking.

When the balance proper performance is confirmed, refer to “[3.3. When Building Into a System](#)” to set up the installation site.

Checking that the operating environment or weighing method is proper

Check each item below. Refer also to “[3.3. When Building Into a System](#)”.

Operating environment

- Is the weighing table solid enough?
- Is the operating environment free from vibration and drafts? Has the breeze break been installed?
- Is there a strong electrical or magnetic noise source such as a motor near the balance?
- Is there a heat source near the balance?

Weighing method

- Does the weighing pan touch the breeze break or anything? Is the weighing pan installed correctly?
- Has the weight value been set to zero by using an RS-232C command (R command) before placing a sample on the weighing pan?
- Is the sample placed in the center of the weighing pan?
- Has the balance been warmed up for 30 minutes or more before weighing?
- Are the leveling feet of the weighing unit placed flat to the installation surface?

If not, the weight value will be unstable or the specified repeatability cannot be obtained.

Improve the installation condition, by securing the weighing unit or reducing the vibration that is conveyed to the weighing unit.

Sample and container

- Has the sample absorbed or lost moisture?
- Has the temperature of the sample, and the container if used, been allowed to equalize to the ambient temperature? Refer to “[3.3. When Building Into a System](#)”.
- Is the sample charged with static electricity? Refer to “[3.3. When Building Into a System](#)”.
- Is the sample of magnetic material such as iron? Use much care when weighing magnetic materials. Refer to “[3.3. When Building Into a System](#)”.

8.2. Asking For Repair

If the balance needs service or repair, contact the local A&D dealer.

The balance is a precision instrument. Use much care when handling the balance and observe the following when transporting the balance.

- Use the original packing material.
- Remove the weighing pan from the weighing unit.

9. Specifications

		AD-4212C-300	AD-4212C-600	AD-4212C-301			
Weighing capacity		320 g	620 g	320 g / 51 g ^{*1}			
Maximum display		320.084 g	620.084 g	320.084 g / 51.0009 g			
Readability (1 digit)		0.001 g	0.001 g	0.001 g / 0.0001 g			
Repeatability (Standard deviation)		0.001 g	0.001 g	0.001 g / 0.0002 g			
Linearity		±0.002 g	±0.005 g	±0.002 g			
Stabilization time in seconds (typical at FAST under good environment)		0-30 g	0.5 s	0-30 g	0.5 s	When the Readability of 0.0001 g is selected	1.3 s ^{*2}
		30-320 g	1.0 s	30-620 g	1.0 s	When the Readability of 0.001 g is selected	1.0 s
Display refresh rate		Approx. 10 times/second* to 50 times/second					
I/O unit	RS-232C	Bi-directional, 2400 bps* to 19200 bps (WinCT-AD4212C communication software provided)					
Sensitivity drift		±2 ppm/°C (10°C to 30°C/50°F to 86°F)					
Operating environment		5°C to 40°C (41°F to 104°F), 85% RH or less (No condensation)					
Allowable eccentric load		0.1 Nm or less (With the center of the weighing pan as a reference)					
Calibration weight provided		200g (Conforming to OIML Class E2)					
External sensitivity adjustment weight		50 g, 100 g, 200 g*, 300 g	50 g, 100 g, 200 g*, 300 g, 400 g, 500 g, 600 g	50 g, 100 g, 200 g*, 300g			
Weighing unit	Dimensions	59 (W) × 231 (D) × 91 (H) mm					
	Weighing pan	50 × 50 mm					
	Mass	Approx. 1.6 kg					
Connection cable		Approx. 10 m					
Unit display mode		g					
AC adapter		Output voltage 12 V (Confirm that the adapter type is correct for the local voltage and power receptacle type)					
Power consumption		Approx. 10 VA (supplied to the AC adapter)					

*1 Smart range (Refer to “5. Smart Range Function”).

*2 When the precision range is used

* Factory setting

		AD-4212C-3000		AD-4212C-6000		AD-4212C-3100	
Weighing capacity		3200 g		6200 g		3200 g / 510 g ^{*1}	
Maximum display		3200.84 g		6200.84 g		3200.84 g / 510.009 g	
Readability (1 digit)		0.01 g		0.01 g		0.01 g / 0.001 g	
Repeatability (Standard deviation)		0.01 g		0.01 g		0.01 g / 0.002 g	
Linearity		±0.02 g		±0.04 g		±0.02 g	
Stabilization time in seconds (typical at FAST under good environment)		0-300 g	0.5 s	0-300 g	0.5 s	When the Readability of 0.001 g is selected	1.3 s ^{*2}
		300-3200 g	1.0 s	300-6200 g	1.0 s	When the Readability of 0.01 g is selected	1.0 s
Display refresh rate		Approx. 10 times/second* to 50 times/second					
I/O unit	RS-232C	Bi-directional, 2400 bps* to 19200 bps (WinCT-AD4212C communication software provided)					
Sensitivity drift		±2 ppm/°C (10°C to 30°C/50°F to 86°F)					
Operating environment		5°C to 40°C (41°F to 104°F), 85% RH or less (No condensation)					
Allowable eccentric load		0.3 Nm or less (With the center of the weighing pan as a reference)					
Calibration weight provided		200g (Conforming to OIML Class E2)					
External sensitivity adjustment weight		50 g, 100 g, 200 g*, 300 g, 500 g, 1000 g, 2000 g, 3000 g		200 g*, 500 g, 1000 g, 2000 g, 3000 g, 4000 g, 5000 g, 6000 g		50 g, 100 g, 200 g*, 300 g, 500 g, 1000 g, 2000 g, 3000 g	
Weighing unit	Dimensions	59 (W) × 231 (D) × 91 (H) mm					
	Weighing pan	50 × 50 mm					
	Mass	Approx. 1.6 kg					
Connection cable		Approx. 10 m					
Unit display mode		g					
AC adapter		Output voltage 12 V (Confirm that the adapter type is correct for the local voltage and power receptacle type)					
Power consumption		Approx. 10 VA (supplied to the AC adapter)					

*1 Smart range (Refer to “5. Smart Range Function”.)

*2 When the precision range is used

* Factory setting

10. External Dimensions

- AD-4212C-300 / 600 / 3000 / 6000 / 301 / 3100

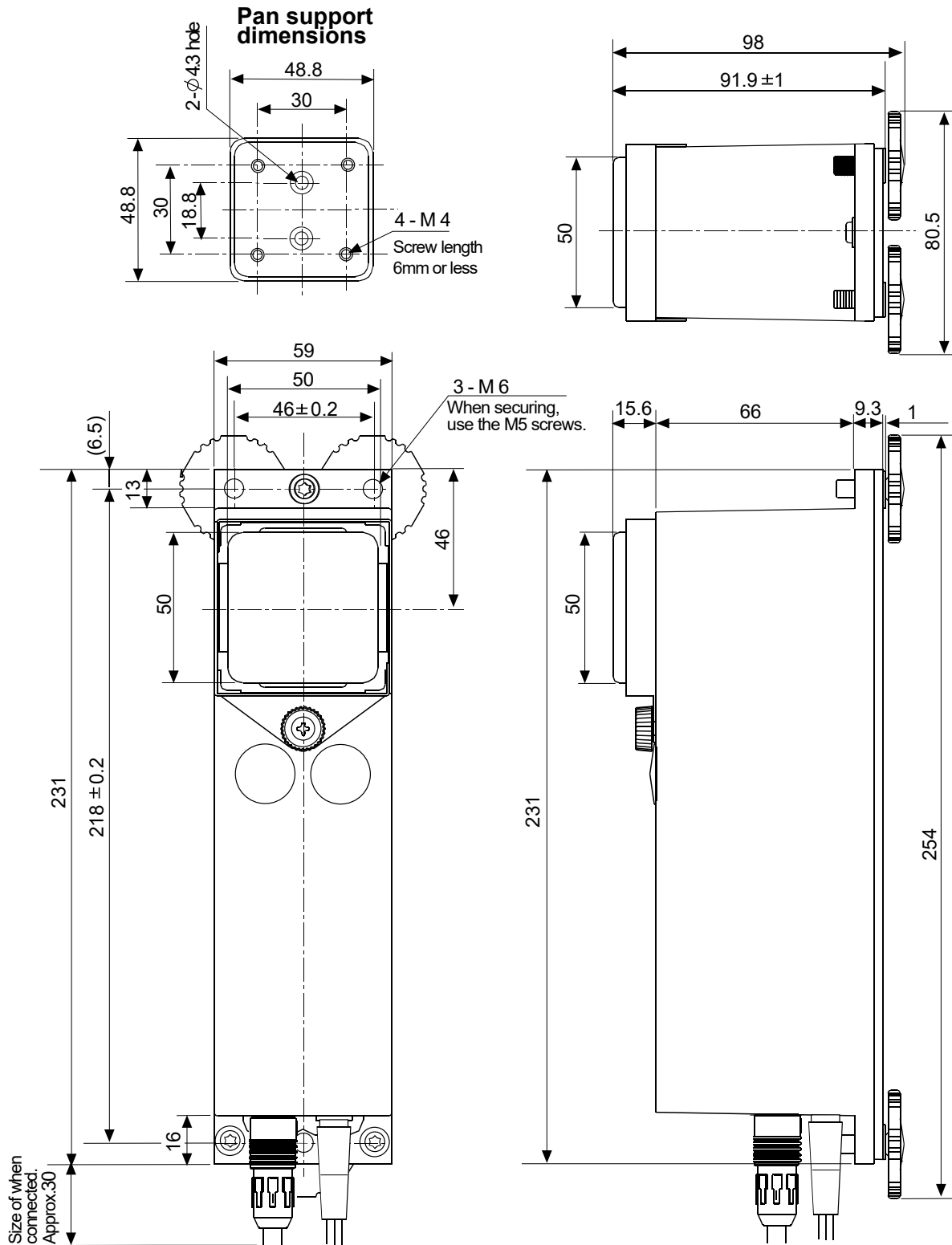

Unit: mm

11. Options

- AX-KO7796-200 RS-232C cable 2 m**
AX-KO7796-500 RS-232C cable 5 m
AX-KO7796-1000 RS-232C cable 10 m (provided with the balance as a standard accessory.)

AX-USB-9P: USB converter/Cable set

- USB converter (D-Sub 9 pin - USB)
 - RS-232C cable (D-Sub 9 pin - D-Sub 9-pin)
- * This RS-232C cable is not used with the AD-4212C series.

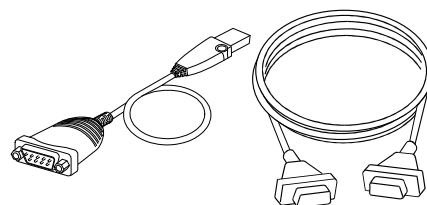

AD-8922A: Remote controller

- The AD-8922A can receive the weighing data, and performs re-zero and sensitivity adjustment manually.
- The AD-8922A can output the data using BCD (AD-8922A-01), comparator (AD-8922A-04), or analog out (AD-8922A-06), by selection of the option installed in the AD-8922A.

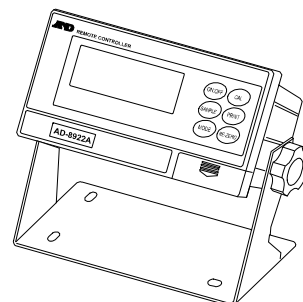

AD-8923-BCD/CC: Remote controller

- The AD-8923-BCD or AD-8923-CC can receive the weighing data, and performs re-zero and sensitivity adjustment manually.
- The AD-8923-BCD can output the data using BCD. The AD-8923-CC can output the data using CC-Link.

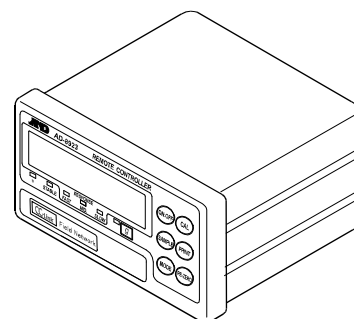

AD-8526: Ethernet converter

- The AD-8526 can convert the AD-4212C RS-232C data, for output to a local area network (LAN).

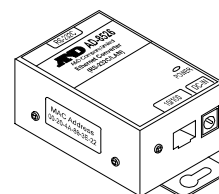

AD-8551R: Modbus RTU converter

- RS-232C output from the weighing unit can be converted to Modbus RTU.

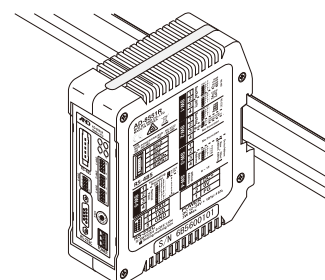

AD-8552EIP: EtherNet/IP converter

- RS-232C output from the weighing unit can be converted to EtherNet/IP.

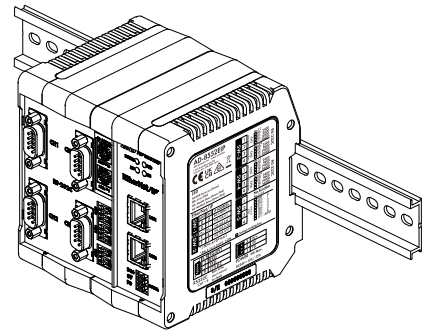

AD-1683: DC static eliminator

- A compact design with efficient static elimination
- No air blowing from a fan allows precision weighing

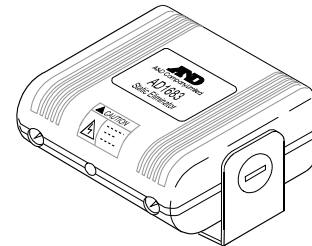

AD-1684A: Electrostatic field meter

- This option measures the amount of the static charge on the sample, tare or peripheral equipment and displays the result.
- If those are found to be charged, discharge them using the AD-1683 DC static eliminator.

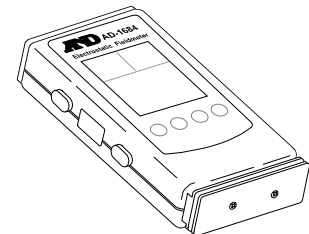

12. Terms

Stable value	The weight value when the stabilization indicator appears.
Environment	Ambient conditions such as vibration, drafts, temperature, static electricity or magnetic fields which affect the weighing operation.
Sensitivity adjustment	Adjustment of the balance using the calibration weight so that it can weigh accurately.
Output	To output the weighing data using the RS-232C interface.
Zero point	A weighing reference point or the zero display. Usually refers to the value displayed when nothing is on the weighing pan.
Digit	Unit of readability. Used for the balance, the minimum displayable weighing value.
Tare	To cancel the weight of a container which is not included in the weighing data.
Re-zero	To set the display to zero.
GLP	Good Laboratory Practice.
Repeatability	Variation in measured values obtained when the same weight is placed and removed repetitively. Usually expressed as a standard deviation. e.g. Standard deviation=1 digit: This means that the measured values fall within ± 1 digit at a probability of about 68%.
Stabilization time	Time required after a sample being placed, until the stabilization indicator illuminates and the weighing data is displayed.
Sensitivity drift	An affect that a change in temperature causes to the weighing data. Expressed as temperature coefficient. e.g. Temperature coefficient = 2 ppm/ $^{\circ}\text{C}$: If a load is 100 g and the temperature changes by 10°C , the value displayed changes by the following value. $0.0002\%/^{\circ}\text{C} \times 10^{\circ}\text{C} \times 100 \text{ g} = 2 \text{ mg}$

THIS PAGE INTENTIONALLY LEFT BLANK.



A&D Company, Limited

3-23-14 Higashi-Ikebukuro, Toshima-ku, Tokyo 170-0013, JAPAN
Telephone: [81] (3) 5391-6132 Fax: [81] (3) 5391-1566

A&D ENGINEERING, INC.

47747 Warm Springs Blvd, Fremont, California 94539, U.S.A.
Tel: [1] (800) 726-3364 Weighing Support:[1] (888) 726-5931 Inspection Support:[1] (855) 332-8815

A&D INSTRUMENTS LIMITED

Unit 24/26 Blacklands Way, Abingdon Business Park, Abingdon, Oxfordshire OX14 1DY
United Kingdom
Telephone: [44] (1235) 550420 Fax: [44] (1235) 550485

A&D AUSTRALASIA PTY LTD

32 Dew Street, Thebarton, South Australia 5031, AUSTRALIA
Telephone: [61] (8) 8301-8100 Fax: [61] (8) 8352-7409

A&D KOREA Limited

한국에이.엔.디(주)
서울특별시 영등포구 국제금융로6길33 (여의도동) 맨하탄빌딩 817 우편 번호 07331
(817, Manhattan Bldg., 33. Gukjegeumyung-ro 6-gil, Yeongdeungpo-gu, Seoul, 07331 Korea)
전화: [82] (2) 780-4101 팩스: [82] (2) 782-4264

OOO A&D RUS

ООО "ЭЙ энд ДИ РУС"
Почтовый адрес:121357, Российская Федерация, г.Москва, ул. Верейская, дом 17
Юридический адрес: 117545, Российская Федерация, г. Москва, ул. Дорожная, д.3, корп.6,
комн. 86
(121357, Russian Federation, Moscow, Vereyskaya Street 17)
тел.: [7] (495) 937-33-44 факс: [7] (495) 937-55-66

A&D Instruments India Private Limited

ऐ&डी इन्स्ट्रुमेंट्स इण्डिया प्रा० लिमिटेड
D-48, उद्योग विहार , फेस -5, गुडगांव - 122016, हरियाणा , भारत
(D-48, Udyog Vihar, Phase-V, Gurgaon - 122016, Haryana, India)
फोन : [91] (124) 4715555 फैक्स : [91] (124) 4715599

A&D SCIENTECH TAIWAN LIMITED.

艾安得股份有限公司
台灣台北市中山區南京東路2段206號11樓之2
(11F-2, No.206, Sec.2, Nanjing E.Rd., Zhongshan Dist., Taipei City 10489, Taiwan, R.O.C.)
Tel : [886](02) 2322-4722 Fax : [886](02) 2392-1794

A&D INSTRUMENTS (THAILAND) LIMITED

บริษัท เอ แอนด์ ดี อินสตรูमेंท์ (ไทยแลนด์)
จำกัด
168/16 หมู่ที่ 1 ตำบลรังสิต อำเภอธัญบุรี จังหวัดปทุมธานี 12110 ประเทศไทย
(168/16 Moo 1, Rangsit, Thanyaburi, Pathumthani 12110 Thailand)
Tel : [66] 20038911