

# MS-74AT / MX-53AT

## INSTRUCTION MANUAL

---

### Heat Drying Moisture Analyzer

MS-74AT



MX-53AT

Please see the materials  
(incl. samples)[here](#)





# Notation for Precautions

## Meaning of Warning Signs

 <b>WARNING</b>	Indicates information where incorrectly handling the product may lead to death or serious injury.
 <b>CAUTION</b>	Indicates information where incorrectly handling the product may lead to injury or damage to property.

## Meaning of Symbols

	The  symbol indicates an action that is required. Details on the action are indicated inside the  or in nearby documents or pictures.
---	---

## Other

<b>CAUTION</b>	Indicates cautionary information regarding the correct use of the product.
<b>ADVICE</b>	Indicates general advice regarding the use of the product and what to do when a mistake is made.
	Indicates a high temperature caution.

## CAUTION

- (1) This instruction manual (hereinafter "this manual") may not be copied, duplicated, modified, or translated, in full or in part, without the written permission of A&D Company, Limited (hereinafter "A&D").
- (2) The content of this manual is subject to change without notice.
- (3) If you have any questions regarding the content of this manual or notice any errors or missing information, please contact A&D.
- (4) A&D shall assume no responsibility for any direct, indirect, special, or consequential damages arising due to flaws in the product or damages or loss of profit caused by the use of the product, even if it is notified of the possibility of those damages occurring in advance. A&D shall also assume no responsibility for claims of rights by third parties. A&D shall assume no responsibility for the loss of any software or data.

©2025 A&D Company, Limited

Microsoft®, Windows®, Word®, and Excel® are trademarks of the Microsoft Group.

The Bluetooth® word mark and logos are registered trademarks owned by Bluetooth SIG, Inc. and any use of such marks by A&D is under license.

Other product names and company names in this manual are trademarks or registered trademarks of their respective owners in Japan and other countries.

# Contents

1.	Cautions Regarding Handling .....	7
1.1.	Cautions Regarding Installation .....	8
1.2.	Precautions During Use .....	9
1.3.	Precautions After Use and For Storage .....	12
2.	Product Overview/Features .....	13
3.	Content of Package and Names of Parts .....	15
4.	Screens and Operations .....	17
4.1.	Standby Screen.....	17
4.2.	Home Screen .....	18
4.3.	Menu Screen .....	19
4.4.	Measurement Screen .....	20
4.5.	Screen Operation Buttons.....	21
4.6.	Input Screens .....	21
4.6.1.	Numeric Value Input Screen .....	21
4.6.2.	Character Input Screen.....	22
5.	Requirements for Preparing to Measure (Installation, Initial Configuration, and Measurement).....	23
5.1.	Installing the Moisture Analyzer .....	23
5.2.	Requirements for Ensuring Correct Measurement .....	26
5.2.1.	Handling Samples .....	26
5.2.2.	Requirements for the Operation Procedure.....	27
5.2.3.	How to Use the Preheat Function .....	28
5.2.4.	Using a Glass Fiber Sheet .....	28
6.	Measurement.....	30
6.1.	Simple Measurement .....	30
6.2.	Programmed Measurement .....	30
6.2.1.	Program Selection Screen .....	31
6.2.2.	Program Search Function .....	32
6.2.3.	Program Copy Function .....	32
6.3.	Preset Programs .....	32
6.4.	Shortcut .....	33
6.5.	Thermal Analysis Mode .....	33
6.6.	Procedure for Measuring the Moisture Content (Simple Measurement with Automatic Measurement Start Enabled) .....	34
6.7.	Weighing.....	37
7.	Measurement Conditions .....	38
7.1.	Overview of Measurement Conditions .....	38
7.1.1.	List of Measurement Conditions .....	38
7.1.2.	How to Change the Measurement Conditions .....	39
7.1.3.	Default setting .....	41
7.2.	Detailed Description of Measurement Conditions .....	42
7.2.1.	Program ID.....	42
7.2.2.	Program name .....	42

7.2.3.	Image .....	42
7.2.4.	Measurement Modes .....	43
7.2.5.	Heating pattern.....	43
7.2.6.	Drying Temperature, Temperature 1, Temperature 2, Drying Time, Ramp Time, and Drying Time for Temperature 1 .....	43
7.2.7.	Measurement accuracy.....	44
7.2.8.	Termination value .....	45
7.2.9.	Configuring the Sample Mass.....	46
7.2.10.	Lower limit and upper limit of sample mass .....	47
7.2.11.	Measurement basis.....	47
7.2.12.	Minimum display during measurement: Minimum display in grams .....	48
7.2.13.	Comparator Upper Limit/Lower Limit .....	48
7.2.14.	Preheating.....	48
7.2.15.	Automatically Starting Measurement .....	49
7.2.16.	Glass Fiber Sheet .....	49
7.2.17.	Sample Pretreatment .....	49
7.2.18.	Correction of measurement results.....	50
8.	Measurement Guide .....	51
8.1.	Automatic Drying Temperature Judgment (RsTemp).....	51
8.2.	Sample mass calculation tool.....	52
8.3.	Sample Pretreatment Guide.....	54
8.4.	Determination of Drying Time.....	55
8.5.	Measurement Examples .....	56
9.	Plastic Measurement Guide .....	57
9.1.	Plastic Drying Temperature Judgment (PITemp).....	58
9.2.	Determination of Drying Time (for the Plastic Measurement Guide).....	58
10.	Check/Adjustment.....	59
10.1.	Function Tests and Adjustment Modes .....	59
10.2.	Daily Check .....	59
10.3.	Test Sample Measurement .....	60
10.3.1.	Performing a Function Check with Sodium Tartrate Dihydrate .....	60
10.3.2.	Test Sample Measurement History .....	60
10.4.	Self-Check Function .....	61
10.5.	Weight Sensor Sensitivity Adjustment.....	61
10.6.	Heater Temperature Adjustment .....	62
11.	Internal Settings .....	63
11.1.	List of Items .....	63
11.2.	Description of Clock Adjustment .....	68
11.3.	Description of Common Settings.....	69
11.4.	Description of Display Settings .....	69
11.5.	Description of Data Output.....	69
11.5.1.	Data output mode .....	69
11.5.2.	Data Format .....	70
11.5.3.	Example Output for Data Format .....	71
11.6.	Backing Up Settings .....	72

12. GLP Output .....	73
12.1. Main Uses .....	73
12.2. Example Measurement Result Output .....	74
12.3. Description of Printed Information .....	79
12.4. Weight Sensor Output for Sensitivity Adjustment .....	82
12.5. Output for Heater Temperature Adjustment .....	83
12.6. Output for Daily Check .....	84
12.7. Output for Test Sample Measurement .....	85
12.8. Output for Automatic Drying Temperature Judgment (RsTemp) .....	86
12.9. Output for Plastic Drying Temperature Judgment (PITemp).....	87
12.10. Output for Determination of Drying Time.....	88
12.11. Output for Thermal Analysis Mode .....	89
13. PDF Report .....	90
13.1. Programmed Measurement Report.....	91
13.2. Test Sample Measurement Report.....	92
13.3. Automatic Drying Temperature Judgment (RsTemp) Report.....	93
14. Measurement History .....	94
14.1. Information Recorded in Measurement History .....	94
14.2. Output of Recorded Results .....	95
15. Password Function .....	96
16. Interface Specifications .....	98
16.1. USB .....	98
16.1.1. USB Type-C (USB device: quick USB, virtual COM).....	98
16.1.2. USB Type-A (USB host: USB flash drive).....	99
16.2. RS-232C.....	100
16.3. Wired LAN .....	101
16.3.1. Network Settings .....	101
16.3.2. Computer IP Address Settings.....	102
16.4. Bluetooth .....	102
17. Connecting to a Peripheral .....	103
17.1. Cables Used for Connecting to a Peripheral.....	103
17.2. Printing Mass and Moisture Content Values to a Printer .....	104
17.2.1. For the AD-8129TH or AD-8127.....	104
17.3. Connecting to a Computer .....	105
17.3.1. Virtual COM Mode.....	105
17.3.2. Quick USB Mode.....	105
17.3.3. RS-232C .....	106
17.3.4. Wired LAN .....	106
17.3.5. Bluetooth .....	106
17.4. Connecting to a USB Flash Drive .....	106
17.5. WinCT-Moisture Communication Software .....	107
17.5.1. RsFig Graph Software for Moisture Content Measurement .....	107
17.5.2. RsTemp Software for Automatic Drying Temperature Detection .....	108
17.5.3. RsSetup Software for Moisture Analyzer Settings .....	109

17.6. WinCT/WinCT-Plus Data Communication Software .....	110
17.6.1. WinCT .....	110
17.6.2. WinCT-Plus .....	110
17.7. Commands .....	111
18. Help and Device Information.....	112
18.1. Help .....	112
18.2. Information .....	113
19. Maintenance.....	114
19.1. Cleaning the Heater .....	114
19.2. How to Replace the Halogen Lamp .....	115
19.3. How to Replace the Power Fuse.....	117
19.4. Factory Settings .....	118
19.5. Troubleshooting.....	118
19.6. Errors Displayed.....	120
20. Disposal .....	121
21. Specifications.....	122
21.1. External Dimensions .....	124
22. Accessories (Sold Separately).....	125
23. Precautions Regarding Electromagnetism .....	127

# 1. Cautions Regarding Handling

## Safety Information

This product is a moisture analyzer based on the principles of thermal mass analysis. It measures properties such as the moisture content and solid content in a sample based on changes in mass caused by heating and drying the sample with a halogen lamp to vaporize the moisture. Do not use it for other purposes.

This manual contains basic information on handling the product. Read it thoroughly before using the product.

The product is designed to be used by an experienced operator.

Using the product in a manner not described in this manual and the separate Quick Start Guide, such as modifying, disassembling, or misusing the product, may be dangerous.

A&D shall not be held responsible for this in any way.

## 1.1. Cautions Regarding Installation

### **⚠️ WARNING**

#### Danger of death due to fire or explosion

- Perform measurement in an appropriate environment.
  - ❑ Do not use the product in a dangerous environment, such as in an atmosphere of flammable gas.
  - ❑ Ensure that the product is installed in an environment with the following temperature and humidity.  
Temperature: 5 to 40°C; Humidity: 85% or lower RH (without condensation)
  - ❑ Do not use the product in a poorly ventilated environment. Using the product in an environment that hinders the dissipation of heat from the moisture analyzer, such as a sealed environment, may cause unexpected rises in temperature or symptoms of poisoning.
- **⚠️** Do not place flammable objects in the vicinity of the product.
  - ❑ The various parts of the moisture analyzer will be at a high temperature during measurement and immediately after measurement, and this can cause objects to catch fire.
  - ❑ Never place objects on the heater cover.
  - ❑ Do not operate the product with any cables or other objects on it.

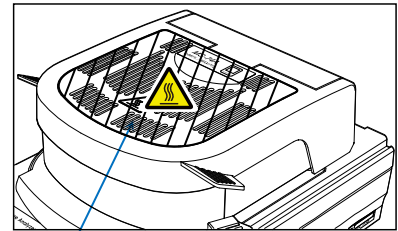

Heater cover

### **⚠️ WARNING**

#### Danger of death or failure due to electrocution

- Check the power supply voltage.  
The compatible power supply voltage is indicated on the rear of the moisture analyzer.  
Confirm that it matches the power supply voltage you are using.
- When connecting the moisture analyzer to the power supply, use the included power cable.
- Ground the moisture analyzer.
- Beware of water leaks. The moisture analyzer is not waterproof.  
Electrocution or failure may occur if water enters the inside of the moisture analyzer.

#### Grounding Method

Grounding with the power outlet

Ground terminal

Power cable

Power outlet with ground terminal

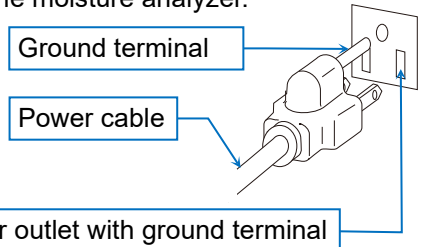

### **⚠️ CAUTION**

#### To ensure correct measurement

- Note the following regarding the high-accuracy electromagnetic balance type weight sensor used by the product.
  - ❑ Install the product on a robust platform (table).
  - ❑ Avoid vibrations.
  - ❑ Install the product in a location where it will not be exposed to air from an air conditioner, etc.

## 1.2. Precautions During Use

### **⚠ WARNING**

#### Danger of death due to fire, explosion, or poisoning

- Do not measure dangerous samples.
- ❑ Do not heat samples that are prone to explosion or combustion or heat samples that emit hazardous substances, as doing so is extremely dangerous. Samples with unknown properties are just as dangerous.
- ❑ If the internal pressure of the sample rises because the surface dries first, the sample may rupture. Do not perform measurement in this case, as it is dangerous.
- ❑ If the sample catches fire, immediately remove the power cable from the power outlet, and perform the appropriate procedures.  
The case of the moisture analyzer uses flame-retardant material (UL94 V-0).
- ❑ Do not place flammable objects in the vicinity of the product.
- ❑ The various parts of the moisture analyzer will be at a high temperature during measurement and immediately after measurement.  
Do not place flammable objects in the vicinity of the product, as doing so may cause a fire.
- ❑ Never place objects on the heater cover.

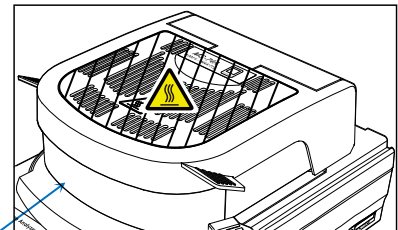

Heater cover

### **⚠ WARNING**

#### Danger of blindness

- Do not look directly at the halogen lamp during heating. Doing so may cause eye pain or vision problems.
- When performing measurement, wear appropriate protective gear, such as goggles and gloves.
- Do not modify or disassemble the moisture analyzer. Doing so may cause failure, electrocution, or fire.  
If you suspect that the product has failed, contact your place of purchase.
- Do not expose the moisture analyzer, power cable, or accessories to extreme temperatures, intense chemical vapors, humidity, impacts, vibrations, or strong magnetic fields. Follow the operating conditions listed in "[21. Specifications](#)".

## ⚠ CAUTION

### ⚠ Danger of burns caused by high temperature surfaces

- Make sure to follow the correct operation methods and procedures.
- ❑ Make sure to place the breeze break, pan holder, sample pan, and sample pan handle correctly.
- ❑ Make sure to hold the heater cover handle when opening or closing the heater cover.

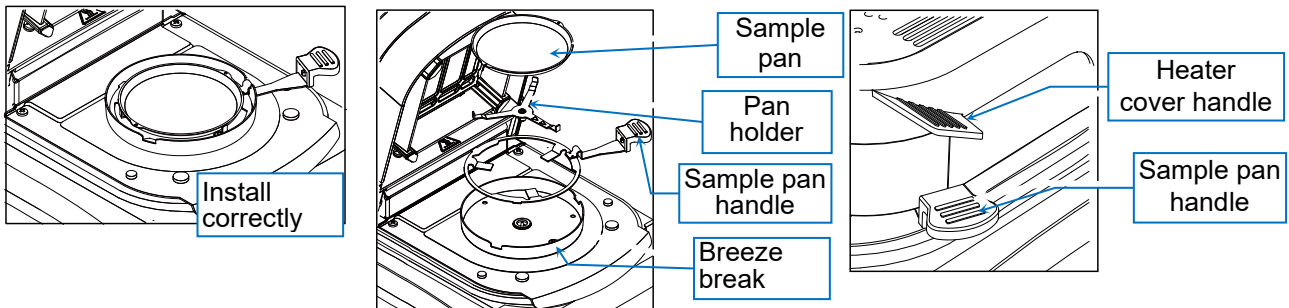

- ❑ The areas with diagonal lines will be at a high temperature during measurement. Only touch the heater cover handle and sample pan handle when operating the product.

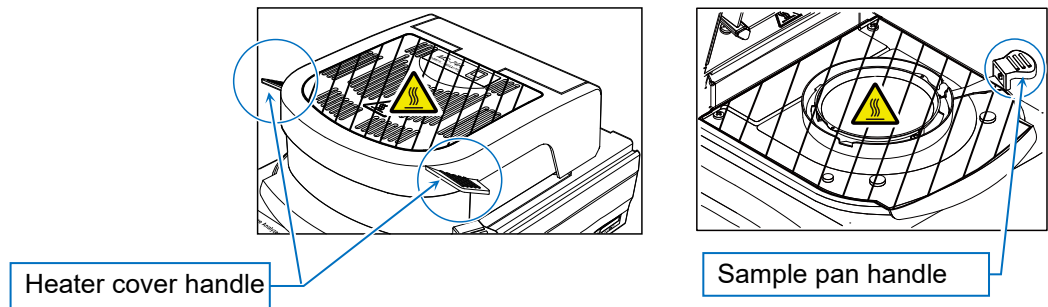

- ❑ Do not touch the high temperature parts such as the inside of the heater cover or sample pan with your hands immediately after heating. Doing so may cause burns. The product will be at a high temperature during measurement and immediately after measurement. When touching the moisture analyzer, make sure to use the specified handle and included tool, and avoid touching the glass housing and the glass and metal (aluminum) parts near the halogen lamp (heater).

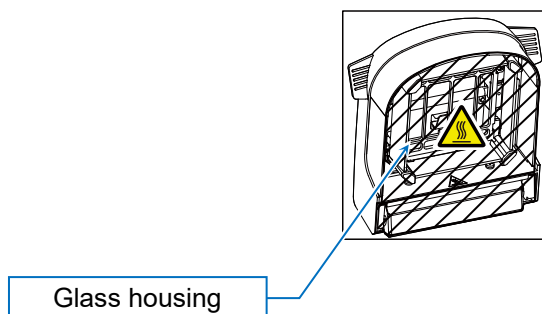

- ❑ The aforementioned glass housing is at a particularly high temperature and can cause burns if you touch it directly.
- ❑ The sample pan and sample pan handle will be at a high temperature immediately after measurement. Cool them in an appropriate location. Use tweezers, etc. when grasping the sample pan.

## CAUTION

### Danger of injury due to inappropriate handling

- Dispose of the used halogen lamp as-is.  
Breaking the halogen lamp can cause glass shards to scatter, which may result in injury.
- Do not drop, strike, or damage glass parts including the halogen lamp.  
Doing so may cause them to break and result in injury.
- The edges of the sample pan are sharp. Take care not to cut your hands.
- Make sure to hold the heater cover handle when opening or closing the heater cover, and take care not to get your hands caught.
- When moving the moisture analyzer, make sure it has cooled down and lift it directly up without tilting it.  
Moving it tilted may cause the heater cover to unexpectedly open and result in injury.

## CAUTION

### Danger of device failure due to inappropriate handling

- It is recommended that you replace the halogen lamp once it has reached its rated life (approx. 5,000 hours), as it may break.
- Do not drop, strike, or damage glass parts including the halogen lamp.  
Doing so may cause them to break.
- Do not allow dust or water to enter the inside of the moisture analyzer.
- Only use accessories and parts manufactured by A&D.
- If the moisture analyzer behaves in an unexpected manner, try removing the power cable from the power outlet and reconnecting it.  
If the product still does not operate normally, request a repair.

## CAUTION

- Caution regarding high temperature heating
  - Do not perform continuous heating for 30 minutes or longer with the product set to 200°C, as the safety mechanism may cut the power supply to the halogen lamp.
  - For safety purposes, the high temperature setting is automatically lowered to 160 °C if one hour elapses after heating starts.
  - The  button on the touch panel is always available during measurement. If you suspect any problem or danger, immediately press the  button to stop measurement.

## 1.3. Precautions After Use and For Storage

### CAUTION

#### Danger of burns caused by high temperature surfaces

- Perform operations after confirming that the various parts of the moisture analyzer have cooled down.
  - In particular, confirm that the area around the glass housing has cooled down before replacing the lamp.

### Device Failure

- Do not allow dust or water to enter the inside of the moisture analyzer.
- When cleaning the product, use a cloth dampened with diluted neutral detergent. Do not use organic solvents or chemical wipes. Doing so may cause product failure.
- Make sure to remove the power plug from the power outlet before performing maintenance.
- When transporting the product, use the dedicated packaging box.
- This unit features software-based temperature monitoring with automatic heating shutdown, as well as an independent non-resettable thermal fuse for final overtemperature protection. If the fuse operates, the lamp will no longer heat. Please request repair service.

### CAUTION

- Clean the glass housing if it gets dirty, or it may not be able to heat properly. For information on handling, refer to "[19.1. Cleaning the Heater](#)".
- Clean the halogen lamp if it has any fingerprints on it, or its life may be shortened. For information on handling, refer to the separate instruction manual.
- Do not subject the moisture analyzer to impacts or drop it, as doing so may damage the halogen lamp or weight sensor.
- Make sure to remove the power plug from the power outlet if the product will not be used for an extended period of time.

## 2. Product Overview/Features

- The display of the product adopts a 5-inch touch panel to enable intuitive operations.
- The product adopts an SHS (Super Hybrid Sensor), the weight sensor used in analytical scales, to enable measurement with high accuracy and high reproducibility.
- Because of its high measurement sensitivity, it only requires a small amount of sample, and this contributes to reduced measurement time.
- The product adopts a 400 W halogen lamp as its heater, which allows the pan temperature to reach 200°C within two minutes.
- The product has the following three measurement modes.
  - Standard mode .....This mode automatically measures moisture content by specifying the measurement accuracy.
  - Timer mode .....This mode measures moisture content by heating for a certain period of time.
  - Custom mode .....This mode enables the user to configure detailed measurement conditions.
- The product has the following four heating patterns.
  - Standard heating .....This mode maintains a constant drying temperature.
  - Ramp heating .....This mode gradually raises the drying temperature.
  - Step heating .....This mode uses two drying temperatures.
  - Quick heating .....This mode reduces the measurement time by heating at high temperature for a certain period of time after measurement starts.
- 300 sets of optimal measurement conditions for various samples can be configured and recalled when performing measurement.
- More than 100 preset programs are registered by default.
- The moisture analyzer can store up to 3000 measurement results.
- The realtime moisture content (%) is displayed in a graph during measurement and the drying rate over time (%/min) is displayed as a numeric value. This can be used to help determine the measurement termination value.
- The product has the following five measurement guide functions to refer to when deciding the measurement conditions.
  - Refer to the mode for measuring the recommended value for the drying temperature ("[8.1. Automatic Drying Temperature Judgment \(RsTemp\)](#)").
  - Refer to the mode for calculating the recommended sample mass ("[8.2. Sample mass calculation tool](#)").
  - Refer to the mode for setting the recommended pre-treatment according to the sample properties ("[8.3. Sample Pretreatment Guide](#)").
  - Refer to the mode for measuring the drying time for the timer mode ("[8.4. Determination of Drying Time](#)").
  - Refer to the mode for displaying an example of actually measuring a sample ("[8.5. Measurement Examples](#)").
- The product has a plastic measurement guide function that configures the sample mass, drying temperature, and drying time for measuring resin (plastic) with a low moisture content of 1% or less. This enables you to easily configure the optimal settings for accurate measurement.

- The product enables sensitivity adjustment of the weight sensor (use of the AD1603-20F1 dedicated weight is recommended) and adjustment of the heater temperature (requires the AX-MXA-43 dedicated temperature adjustment kit). When performing adjustment, data can be output in response to GLP/GMP/ISO requests.
- The product has a self-check function for checking for electrical circuit and temperature control problems. It also has a function for measuring a test sample in order to check the performance of the moisture analyzer.
- The password function enables the use of the moisture analyzer and setting changes to be restricted.
- The product is equipped with USB, RS-232C, USB host, wired LAN, and *Bluetooth*<sup>®</sup> interfaces as standard for easily connecting to a computer or printer.
- The dedicated WinCT-Moisture software has a function for the real-time graphing of the drying rate and a function for determining the appropriate drying temperature.
- You can also download the WinCT data communication software from the A&D website for easily importing data to a Windows computer.
- The included sample pan is reusable. Disposable aluminum pans are also included as standard.
- The product includes test samples for checking the accuracy of measurement.
- The product has glass fiber sheets for precisely measuring liquid samples in a short time.

## Principle and Intended Use

- The moisture analyzer is based on the principle of thermal mass analysis. It measures properties such as the moisture content and solid content in a sample based on changes in mass by heating and drying the sample with a halogen lamp to vaporize the moisture.

### 3. Content of Package and Names of Parts

- Confirm that all the parts are included.
- Retain the packaging to use for transporting or repairing the product.

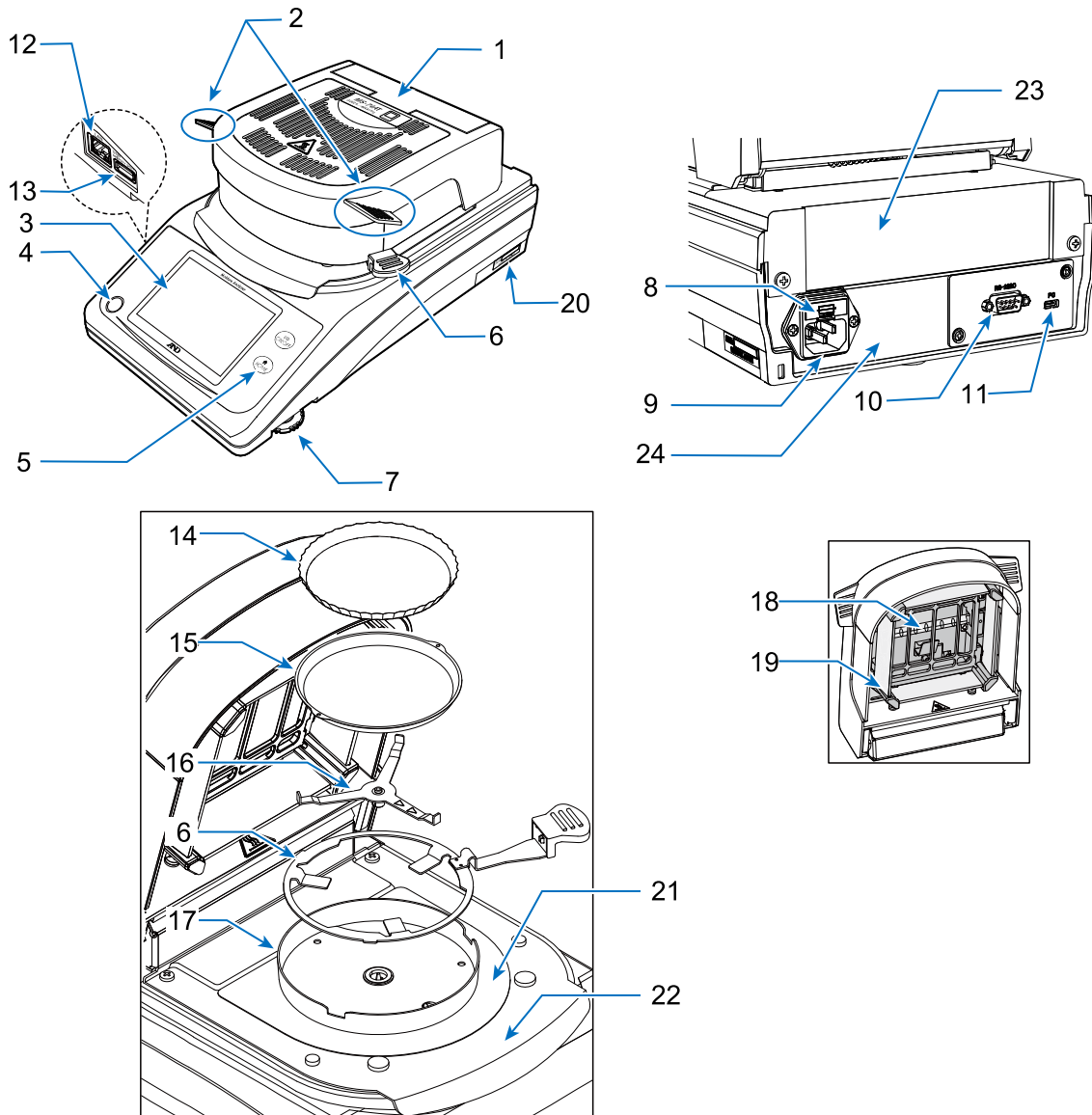

No.	Name	Material
1	Heater cover	
2	Heater cover handle	PBT
3	Display	
4	Leveler	
5	Keys	
6	Sample pan handle	SUS316, ABS
7	Foot adjuster	Elastomer, SUS

No.	Name	Material
13	Memory dedicated USB Type-A connector	
14	Disposable aluminum pan	
15	Sample pan	Aluminum
16	Pan holder	SUS304, SUS316
17	Breeze break	SUS304 (galvanized)
18	Halogen lamp	
19	Glass housing	Glass, aluminum die-cast
20	Serial number	
21	Floor panel for insulation	SUS304
22	Floor panel	PBT
23	Main unit upper case	ABS
24	Main unit lower case	Aluminum die-cast (coated)

## Accessories

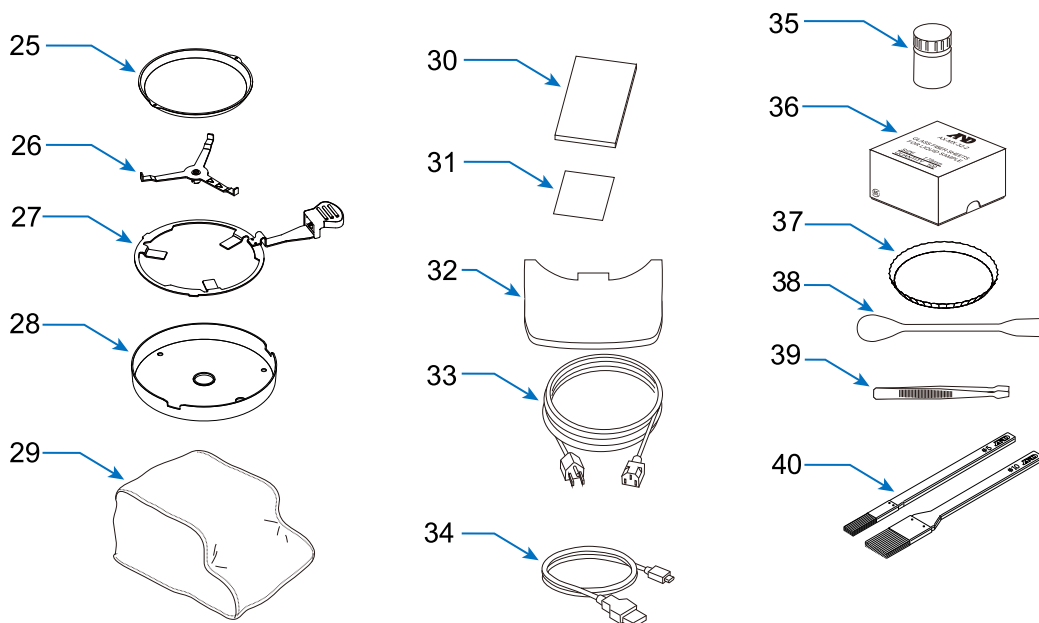

No.	Name	MS-74AT	MX-53AT	Accessory number
25	Sample pan		× 20	AX-MXA-31
26	Pan holder		Yes	
27	Sample pan handle		× 2	AX-MXA-35
28	Breeze break		Yes	
29	Body cover		Yes	AX-MXA-39
30	Quick Start Guide		Yes	
31	Warranty card		Yes	
32	Display protective cover		Yes	AX-MXA-38
33	Power cable		Yes	
34	USB cable (2 m)*2 (Type-A — Type-C)		Yes	AX-KO7919-200
35	Test sample*1		Yes	AX-MX-33
36	Glass fiber sheet		× 100	AX-MXA-32-2
37	Disposable aluminum pan		× 100	AX-MXA-30
38	Spoon		Yes	AX-MX-37
39	Tweezers		Yes	AX-MX-36
40	Cleaning brushes (large/small)		Yes	AX-CLEANING-SET

Yes: Included; -: Not included

\*1 30 g of sodium tartrate dihydrate

\*2 UL certified products do not include a USB cable.

## 4. Screens and Operations

### 4.1. Standby Screen

- Press the **ON:OFF** key or **HOME** key or touch the screen to switch to the home screen. However, if [Notification when display is on] is enabled for the daily check function, the display switches to the daily check start screen when you press the **ON:OFF** key or touch the screen.

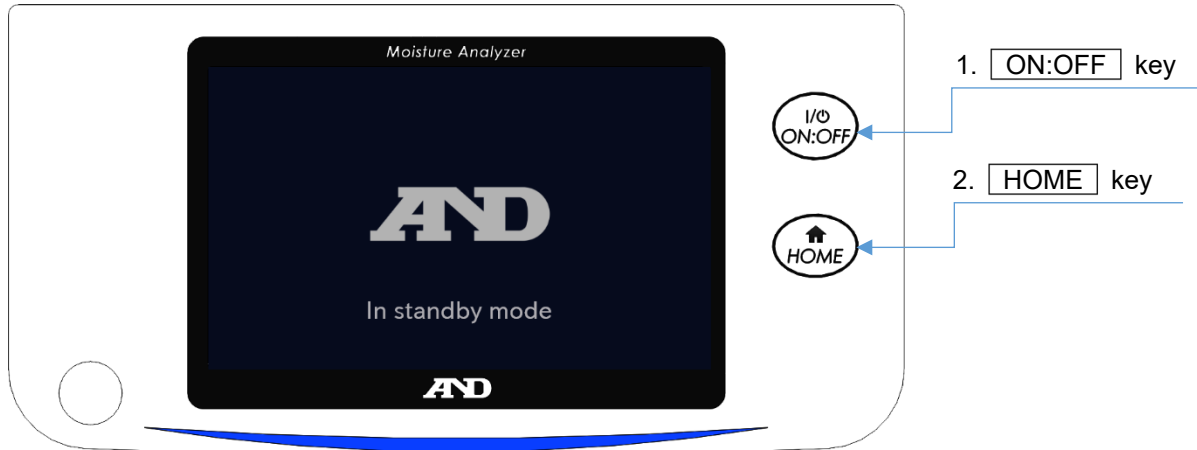

1	<b>ON:OFF</b> key	When on the standby screen, switches to the home screen. When on a screen other than the standby screen, switches to the standby screen.
2	<b>HOME</b> key	Switches to the home screen.

## 4.2. Home Screen

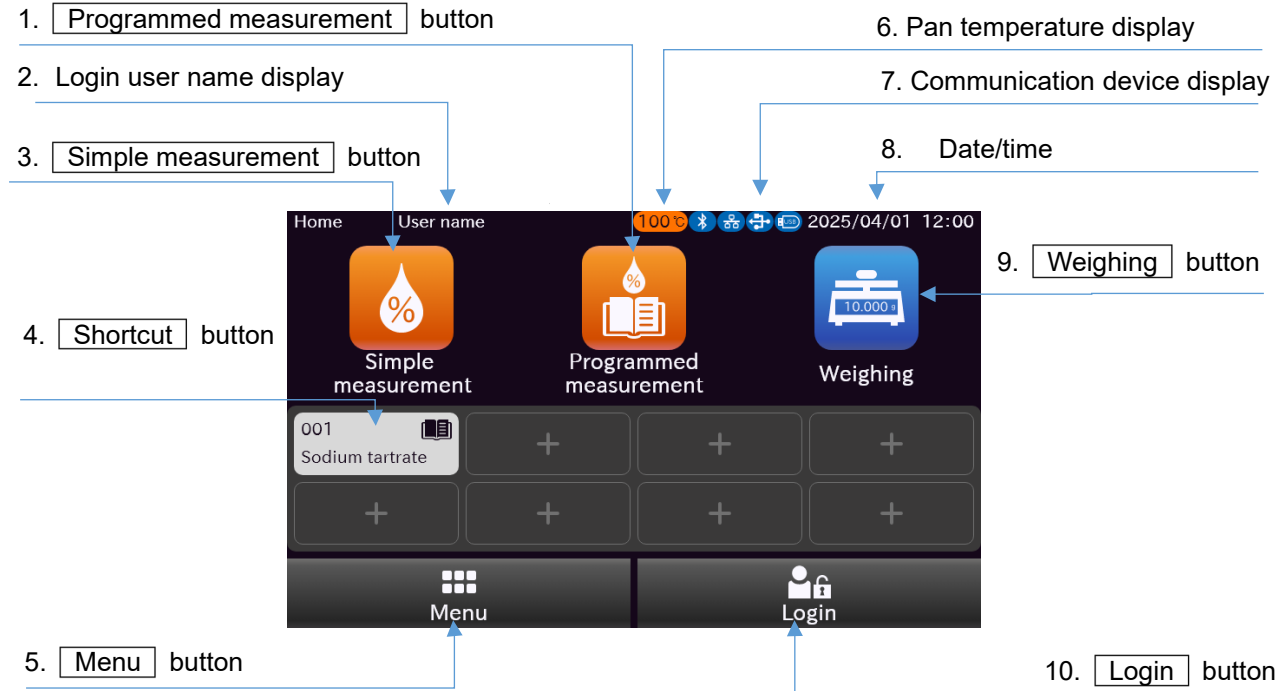

1	Programmed measurement button	Selects the program and starts measurement.
2	Login user name display	Displays the name of the user that is logged in.
3	Simple measurement button	Starts measurement using only the pan temperature and measurement accuracy settings.
4	Shortcut button	Starts measurement using a program registered to the shortcuts.
5	Menu button	Displays the menu screen.
6	Pan temperature display	Displays the temperature when the pan is at a high temperature.
7	Communication device display	Displays the communication device that is connected.
8	Date/time display	Displays the current date and time.
9	Weighing button	Displays the weighing screen.
10	Login button	Displays the login screen.

## 4.3. Menu Screen

1. Measurement history button

2. Check/adjustment button

3. Measurement guide

4. Back button

5. Settings button



6. Help button

7. Additional functions

8. Plastic measurement guide button

9. Information button

1	Measurement history button	Displays the measurement history screen.
2	Check/adjustment button	Displays the check/adjustment screen.
3	Measurement guide button	Displays the measurement guide screen.
4	Back button	Displays the home screen.
5	Settings button	Displays the settings screen.
6	Help button	Displays the help screen.
7	Additional functions button	Displays the additional functions screen.
8	Plastic measurement guide button	Displays the plastic measurement guide screen.
9	Information button	Displays the information screen.

## 4.4. Measurement Screen

- You can start measurement using the **Simple measurement** button and **Programmed measurement** button on the home screen.

1. Message display

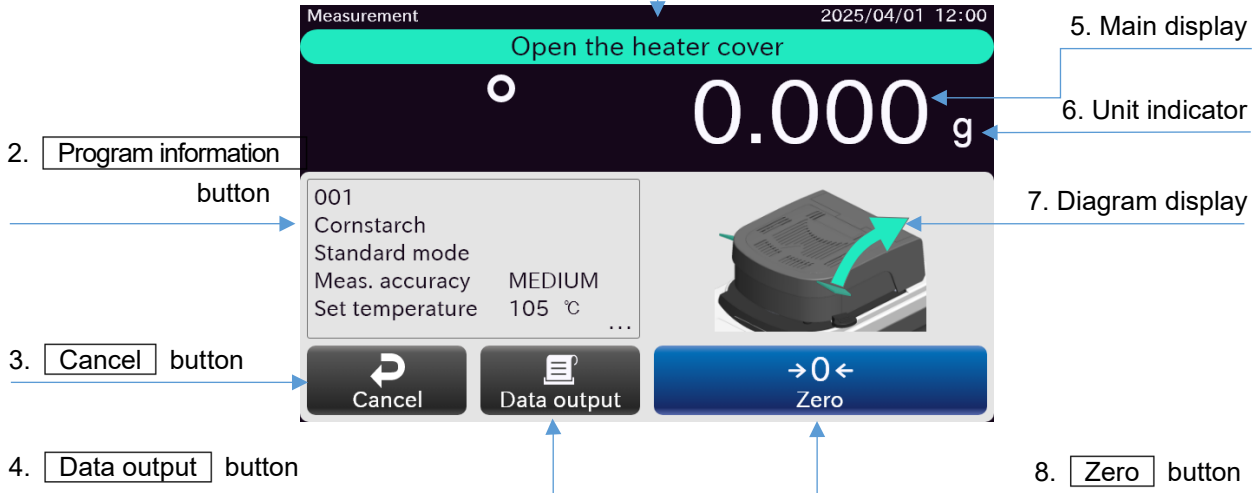

1	Message display	Displays the measurement procedure.
2	<b>Program information</b> button	Displays the program information screen.
3	<b>Cancel</b> button	Ends measurement and returns to the home screen.
4	<b>Data output</b> button	Outputs (prints) the mass value and moisture content.
5	Main display	Displays the mass value and moisture content.
6	Unit indicator	Displays the unit of the mass value and moisture content.
7	Diagram display	Displays diagrams indicating the measurement procedure and graphs.
8	<b>Zero</b> button	Resets the displayed mass to zero.

## 4.5. Screen Operation Buttons

- The main operations of the moisture analyzer are performed on the touch panel of the display unit. Perform operations by touching buttons, indicator buttons, and selection buttons on the screen.

### CAUTION

- Operations such as double-click, drag, and flip are not available. Do not perform such operations, as they may cause malfunction.
- Use your finger to perform touch operations, and do not use any hard objects.

### Example Operations

- Touch the **Back** button to return to the previous screen.
- Touch an indicator button to perform entry or execute an operation, depending on the displayed screen.
- Touch a selection button to display options.

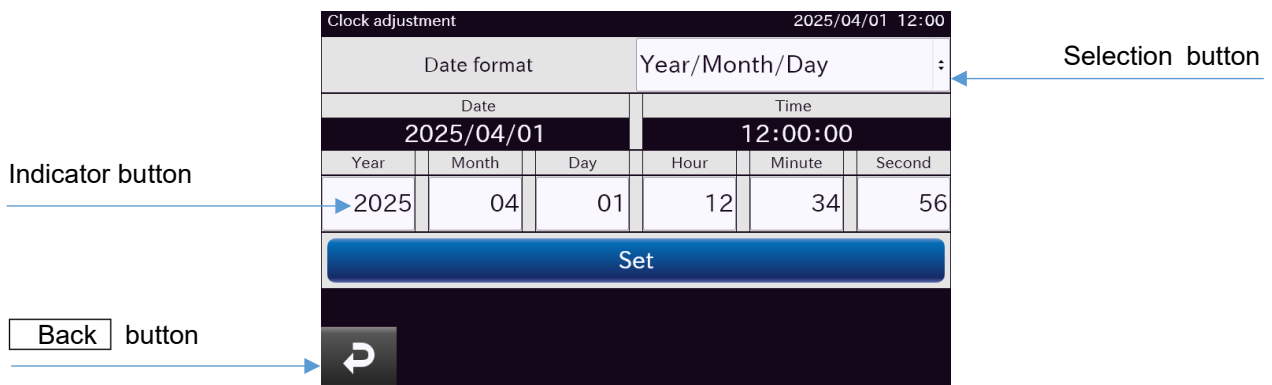

## 4.6. Input Screens

### 4.6.1. Numeric Value Input Screen

- The numeric value input screen is displayed when inputting a numeric value.

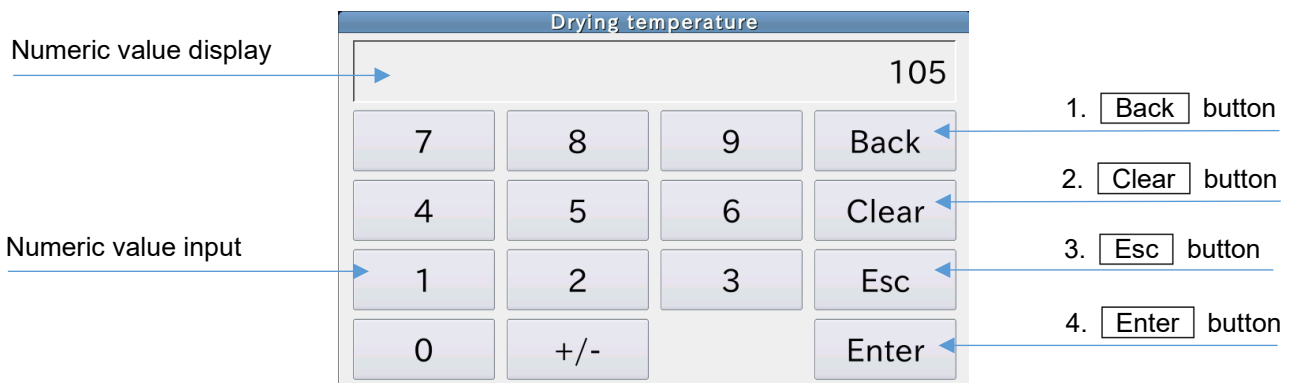

1	<b>Back</b> button	Deletes the value before the cursor.
2	<b>Clear</b> button	Deletes all the values that are input.
3	<b>Esc</b> button	Returns to the previous screen without reflecting the input values.
4	<b>Enter</b> button	Touch this after inputting a value to apply the value and return to the previous screen. However, if the value is outside the valid range, it will not be applied before returning to the previous screen.

## 4.6.2. Character Input Screen

- The character input screen is displayed when inputting characters.
- On the character input screen, you can input single-byte alphanumeric characters and single-byte symbols.

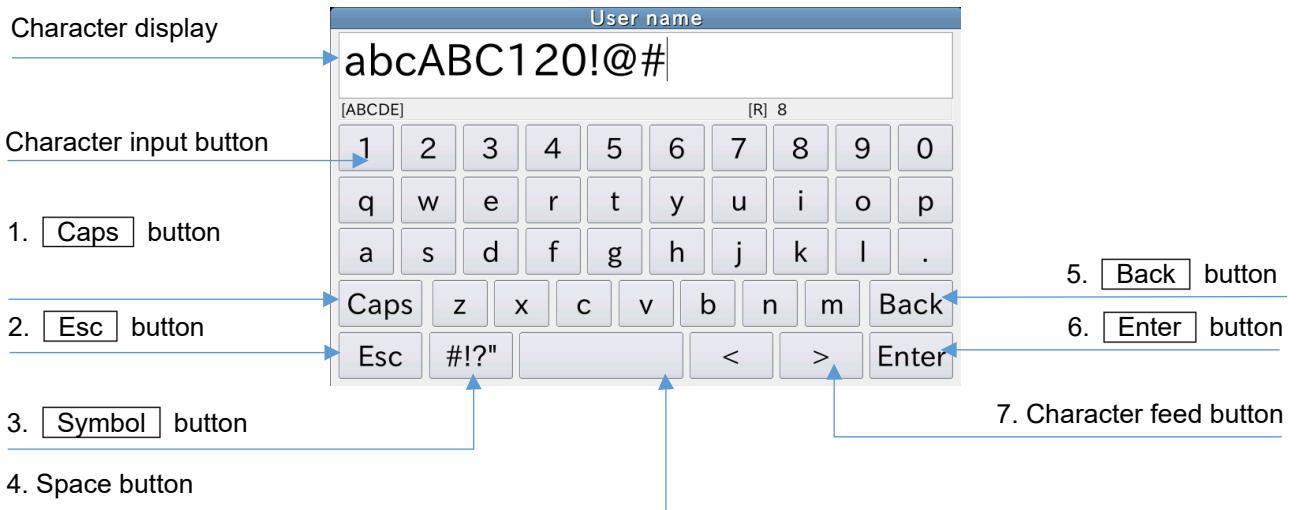

1	Caps button	Switches between lower case and upper case characters. Available when inputting single-byte alphanumeric characters.
2	Esc button	Returns to the previous screen without reflecting the input values.
3	Symbol button	Switches the displayed characters to single-byte symbols. When inputting double-byte kana, switches the displayed characters to double-byte symbols.
4	Space button	When inputting single-byte alphanumeric characters or single-byte symbols, inputs a space (ASCII code 20h). In other cases, inputs a double-byte space.
5	Back button	Deletes the value before the cursor.
6	Enter button	Touch this after inputting a value to apply the value and return to the previous screen.
7	Character feed button	Moves the input cursor.

# 5. Requirements for Preparing to Measure (Installation, Initial Configuration, and Measurement)

## 5.1. Installing the Moisture Analyzer

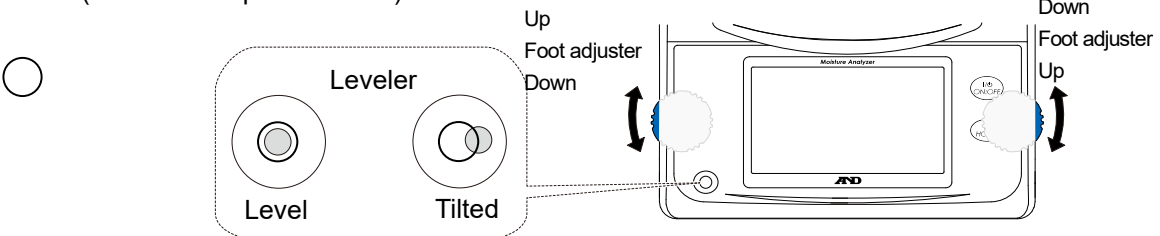
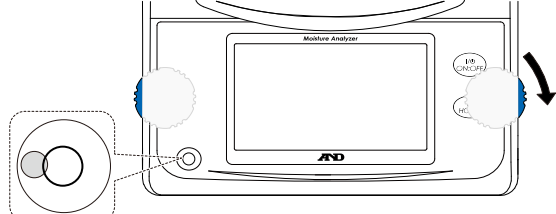
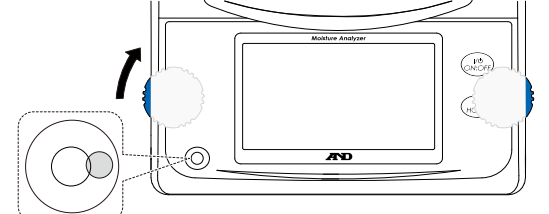
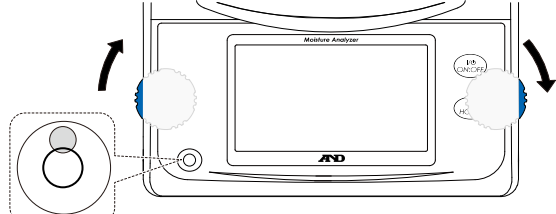
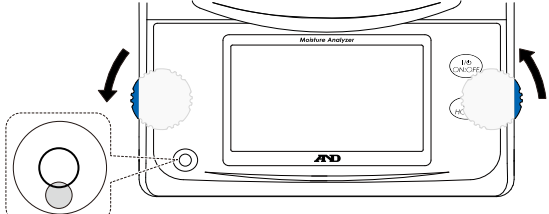
Step	Description
1.	Refer to "1.1. Cautions Regarding Installation" to select the installation location.
2.	<p>Turn the left and right adjustable feet until the air bubble of the leveler is in the center of the black circle. (To make the product level)</p> 
<p>When the air bubble is too far left Turn the foot adjuster on the front right clockwise.</p> 	<p>When the air bubble is too far right Turn the foot adjuster on the front left clockwise.</p> 
<p>When the air bubble is too far backward Turn the two foot adjusters on the front clockwise.</p> 	<p>When the air bubble is too far forward Turn the two foot adjusters on the front counterclockwise.</p> 

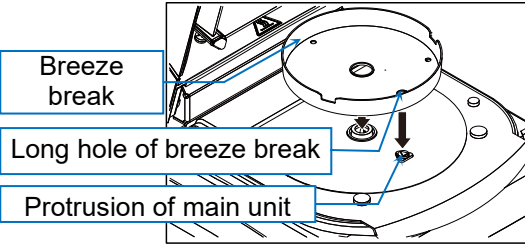
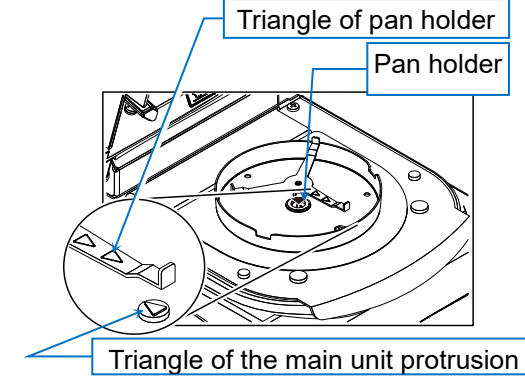
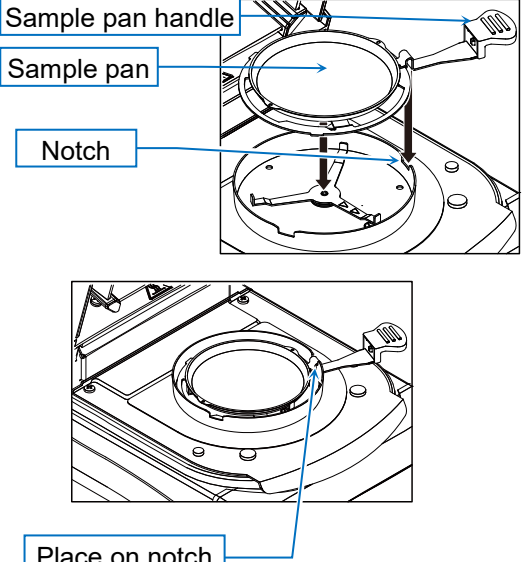
Step	Description	Diagram
3.	Align the long hole of the breeze break with the protrusion of the main unit.	
4.	Align the triangle of the pan holder with the triangle of the main unit.	
5.	<p>Place the sample pan on the sample pan handle, then align the sample pan handle with the notch of the breeze break.</p> <p><b>CAUTION</b></p> <ul style="list-style-type: none"> <li>When using a disposable aluminum pan, make sure to place it on the sample pan.</li> </ul>	

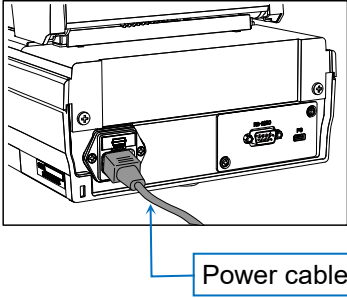
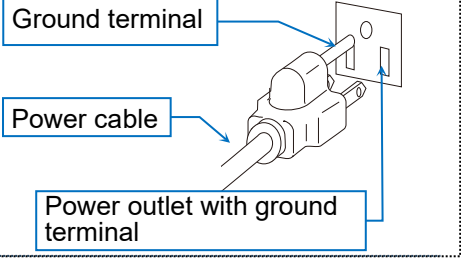
Step	Description	Diagram
6.	<p>Connect the power cable and ground the moisture analyzer.</p> <p><b>ADVICE</b></p> <ul style="list-style-type: none"> <li>When measuring low moisture content less than 1%, it is recommended that you power the product for 30 minutes or more before performing measurement.</li> </ul>	 <p>Power cable</p> <p><b>Grounding Method</b></p> <p>Grounding with the power outlet</p>  <p>Ground terminal</p> <p>Power cable</p> <p>Power outlet with ground terminal</p>

## 5.2. Requirements for Ensuring Correct Measurement

### 5.2.1. Handling Samples



- Perform measurement with an appropriate amount of sample. If the amount of sample is small, the accuracy of calculating the moisture content may be adversely affected, which can also affect the reproducibility of the measurement results.
- When measuring samples with an expected moisture content of 1% or less (for example, plastic), the moisture content will be unable to be accurately measured if the amount of sample is small, because the change in mass before and after heating will also be small because the moisture mass is small. Refer to the table below for the estimated sample mass required for measurement.

Expected moisture content	0.5 to 1%	0.1 to 0.5%	Less than 0.1%
Required sample mass	2 g or more	5 g or more	20 g or more

- If the moisture content is less than 1% and the sample mass is insufficient to ensure accuracy, a “To improve accuracy” button appears on the result screen. Pressing this button allows you to check the recommended sample mass. In addition, when the measurement mode is Custom mode or Timer mode, you can set the recommended sample mass as the “Upper limit of sample mass” and “Lower limit of sample mass” in the measurement program.
- When measuring materials such as plastic that are prone to static electricity, we recommend that the AD-1683A is used to eliminate static.

Example	Sample	Expected moisture content	Required sample mass	Drying temperature	Termination value
	PBT	0.08%	20 g	160°C	0.005%/min
	ABS	0.43%	10 g	140°C	0.005%/min

- When repeatedly measuring the same sample, it is recommended that you measure the same amount of sample each time.
 



- For a sample with large granules, crush the sample before measurement to make it easier for the moisture to vaporize.
- Spread the sample out evenly on the pan to ensure that it will be evenly heated.
- A heat drying moisture analyzer is suitable for measuring the moisture content of samples where mainly only water will vaporize. Mass changes due to the vaporization or degradation of substances other than water will also be measured as moisture.
- For a liquid sample or sample that forms a film on its surface, the use of a glass fiber sheet (AX-MXA-32-2) is recommended. Refer to "[5.2.4. Using a Glass Fiber Sheet](#)".

---

## 5.2.2. Requirements for the Operation Procedure

---

- Before performing measurement, press the  key and confirm that the displayed mass stabilizes at zero.
- Before starting measurement, confirm that the sample mass is sufficiently stable.
- Configure an appropriate measurement termination value. Use the drying rate over time (displayed as %/min) when measurement stops as a guide.
- When repeating measurement, there may be a difference between the first measurement result and the subsequent measurement results, due to the heat distribution of the various parts of the moisture analyzer. Ignore the first measurement result or perform preheating. (Refer to "[5.2.3. How to Use the Preheat Function](#)".)
- If you place a sample on the sample pan while the pan is hot, moisture will vaporize before measurement, and the moisture content will not be measured accurately. Recommended methods for preventing this include alternating between two sample pans when performing consecutive measurements and waiting about 10 minutes after measurement before performing the next measurement to improve reproducibility.
- Do not stack sample pans when performing measurement.
- Avoid air conditioner convection and vibrations in the installation location. Otherwise measurement errors may occur or the measured value may not stabilize. The MS-74AT in particular is susceptible to such disturbance, as it is high resolution.
- Accurate temperature control may not be possible if there is only a small difference between the sample pan temperature and the surrounding temperature.  
(Example) When the sample pan temperature is set to around 30°C to 50°C, the product will be more susceptible to the surrounding temperature.
- Use the [Heating in progress] indicator to check the operation of the halogen lamp.  
(Example) When the sample pan temperature is set to a low temperature, the halogen lamp will light weaker.

### 5.2.3. How to Use the Preheat Function

- The preheat function raises the temperature around the sample pan before performing moisture content measurement.
- The preheat function is effective for increasing the accuracy of moisture content measurement.
- The preheat function is effective when repeatedly measuring the same sample.  
(Because the heating conditions vary if the starting temperature differs between the first time and the second and subsequent times, the result of measuring the moisture content may also vary.)
- The preheat temperature is automatically determined according to the set measurement conditions.
- Stop preheating at a time of your choice and start measuring the moisture content.

If 30 minutes elapse since preheating started, it will automatically stop.

[Heating pattern] <sup>*1</sup> setting	Preheat temperature	Time
Standard heating	[Drying temperature] <sup>*2</sup> setting	Maximum 30 min
Ramp heating	[Drying temperature] <sup>*2</sup> setting	
Step heating	[Temp Step 2] <sup>*2</sup> setting value	
Quick heating	[Drying temperature] <sup>*2</sup> setting	

\*1 Refer to "7.2.5. Heating pattern"

\*2 Refer to "7.2.6. Drying Temperature, Temperature 1, Temperature 2, Drying Time, Ramp Time, and Drying Time for Temperature 1"

## CAUTION

- If the sample pan is pre-heated, make sure to replace it with a pan at room temperature before performing measurement. If you use a heated pan, moisture will vaporize when the sample is placed on the pan and prevent accurate measurement.

### 5.2.4. Using a Glass Fiber Sheet

- A glass fiber sheet is used for liquid samples, samples that melt when heated, and samples with a surface that is prone to carbonization. Using a glass fiber sheet promotes moisture vaporization and enables faster and more accurate moisture measurement.
- 100 glass fiber sheets are included in a box (AX-MXA-32-2).  
A box is included with the MS-74AT/MX-53AT as standard.
- By setting the [Glass fiber sheet] measurement conditions for the measurement program, instructions for using a glass fiber sheet or filter paper are displayed on the screen when performing measurement.

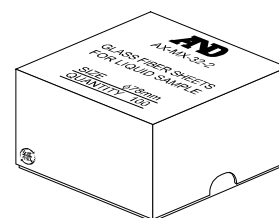

Set value	Instruction when placing the sample pan	Instruction when placing the sample
None	None	None
Use one sheet: Cover the sample	Place one glass fiber sheet	Cover the sample with a glass fiber sheet
Use one sheet: Soak the sample	Place one glass fiber sheet	Soak a glass fiber sheet with the sample
Use two sheets: Sandwich the sample	Place two glass fiber sheets	Sandwich the sample with glass fiber sheets
Use one filter paper: Soak the sample	Place one filter paper	Soak a filter paper with the sample
Use two filter papers: Sandwich the sample	Place two filter papers	Sandwich the sample with filter papers

### Example use 1: Liquid sample or sample that melts when heated

- Soak the glass fiber sheet with the sample to increase the surface area and space required for moisture vaporization to make it easier for the moisture to vaporize. The glass fiber sheet will also help prevent a hard film from forming on the surface of the sample due to heating.
- For liquid samples with high surface tension or high viscosity that do not spread easily, using filter paper (AX-MX-32-1) helps the sample spread more evenly.
- Liquid samples with high moisture content  
Examples: Milk, yogurt, liquid glue, hand soap, etc.
- Samples that melt when heated and stick to the pan  
Examples: Gum, caramel, etc.
- Samples with high surface tension or high viscosity  
Examples: Honey, condensed milk, resin paint, etc.

### Example use 2: Sample with a surface prone to carbonization

Cover the sample with the glass fiber sheet to reduce the sample surface carbonization due to heating.

Preventing sample carbonization enables stable measurement of the moisture content.

- Samples including a lot of sugar, protein, or oil  
Examples: Honey, soy bean powder, tea leaves, cookies, etc.
- Samples with a black surface that are prone to burning  
Examples: Coffee, peanuts, etc.

## 6. Measurement

Measure the moisture content.

The following five measurement applications are available.

Measurement application	Access method
Simple measurement	[Home] > [Simple measurement]
Programmed measurement	[Home] > [Programmed measurement]
Preset programs	[Home] > [Programmed measurement] > [Preset programs]
Shortcut	[Home] > [Shortcut]
Thermal analysis mode	[Home] > [Menu] > [Additional functions] > [Thermal analysis mode]

### 6.1. Simple Measurement

Access method: [Home] > [Simple measurement]

- Performs simple measurement of moisture content by setting the drying temperature and measurement accuracy only. This is useful for finding the appropriate conditions when measuring the moisture content for the first time.
- You can also touch the **Open detailed settings** button to change the other measurement conditions. For information on measurement conditions, refer to "[7.2. Detailed Description of Measurement Conditions](#)".
- You can touch the **Copy** button to copy the measurement conditions for simple measurement to a program for programmed measurement.
- By enabling GLP output in the settings, you can touch the **Data output** button on the result screen to output the results.  
For an example of the output result, refer to "[12.2. Example Measurement Result Output](#)".
- You can also touch the **Export file** button to output a PDF file to a USB flash drive.  
For an example of the output result, refer to "[13.1. Programmed Measurement Report](#)".

### 6.2. Programmed Measurement

Access method: [Home] > [Programmed measurement]

- Performs measurement using sample measurement conditions registered in advance.
- 300 sets of programs can be registered.
- You can touch the **Copy** button on the program editing screen to copy the measurement conditions of the selected program to another program.
- You can touch the **Delete** button on the program editing screen to restore the default values for the measurement conditions of the selected program.
- By enabling GLP output in the settings, you can touch the **Data output** button on the result screen to output the results.  
For an example of the output result, refer to "[12.2. Example Measurement Result Output](#)".
- You can also touch the **Export file** button to output a PDF file to a USB flash drive.  
For an example of the output result, refer to "[13.1. Programmed Measurement Report](#)".

## 6.2.1. Program Selection Screen

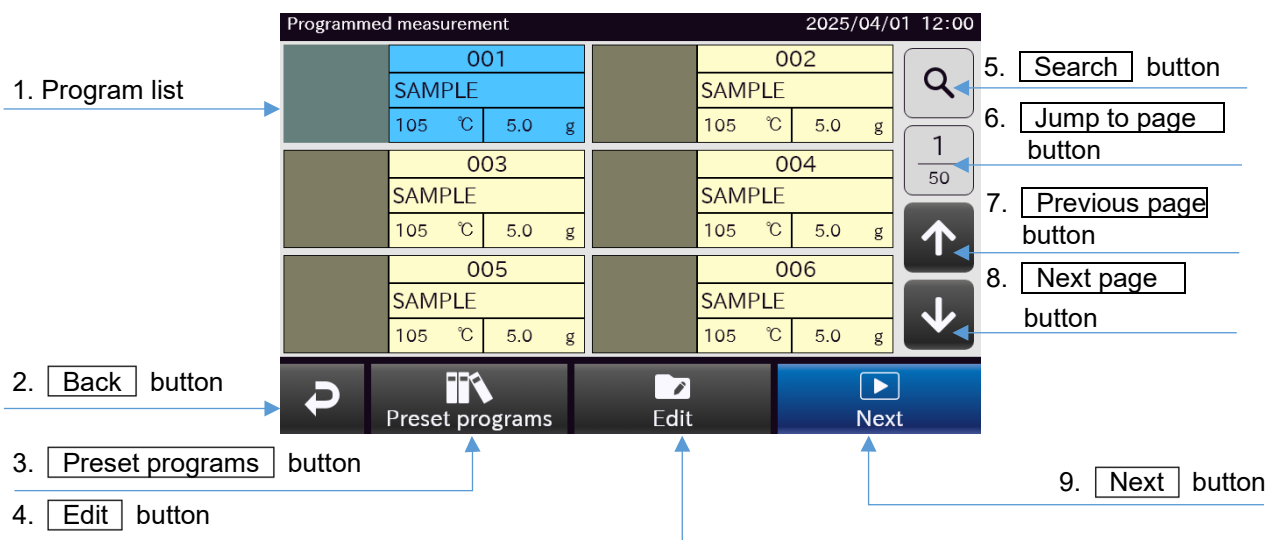

1	Program list	Displays the list of programs. Touch a program to switch the program and display the selected program in blue. An image, program number, program name, drying temperature, and sample mass (median of upper limit and lower limit) are displayed for each program.
2	Back button	Displays the home screen.
3	Preset programs button	Displays the preset programs screen.
4	Edit button	Displays the program editing screen. You can set the measurement conditions for the selected program. For information on measurement conditions, refer to "7.2. Detailed Description of Measurement Conditions".
5	Search button	Displays the program search screen. For information on the search function, refer to "6.2.2. Program Search Function".
6	Jump to page button	Displays the current page number. Touch this and enter a page number to jump to that page.
7	Previous page button	Displays the previous page.
8	Next page button	Displays the next page.
9	Next button	Starts measurement with the selected program.

## 6.2.2. Program Search Function

- You can use the program search function to quickly find a specific program from among the 300 sets of available programs.
- The search function is available from the magnifying glass button on the program selection screen for programmed measurement.
- Two search methods are available.

Search method	Description
Search by program number	Search for a number from 001 to 300. Enter a number to display the corresponding program. You can then start measurement or edit the measurement conditions.
Search by program name	Search for a phrase included in the program name. Enter a phrase to display a list of programs including that phrase. You can then select a program from the list to start measurement or edit the measurement conditions.

## 6.2.3. Program Copy Function

- You can use the program copy function to duplicate the measurement conditions of the selected program.
- The following combinations of copy source and copy destination are available.

Copy source	Copy destination
Simple measurement	Programmed measurement
Programmed measurement	
Preset programs	

- Touch the  button on the start screen or edit screen of the above copy source measurement application to display the screen for selecting the copy destination program. Select the copy destination program and touch the  button to duplicate the measurement conditions.

## 6.3. Preset Programs

Access method: [Home] > [Programmed measurement] > [Preset programs]

- You can perform measurement with more than 100 sample measurement conditions registered in the moisture analyzer.
- Seven categories of samples are registered.



Category	
Household goods	Pharmaceuticals
Food A	Food B
Industrial goods	Plastics
Others	

- The measurement conditions cannot be changed.
- Program numbers are assigned to the preset programs from number 301.
- You can touch the  button to copy the measurement conditions for the preset program to a program for programmed measurement.

## 6.4. Shortcut

Access method: [Home] > [Shortcut]

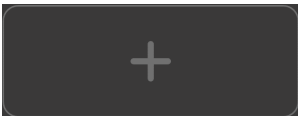
- You can recall frequently used programmed measurement or preset programs from the home screen.
- You can register a maximum of eight shortcuts.
- If the programmed measurement is registered in a shortcut, you can touch the **Edit** button of the shortcut to change the measurement conditions.
- You can touch the **Measurement history** button for a shortcut to check the measurement results that are saved.
- The appearance of shortcuts change as indicated below.

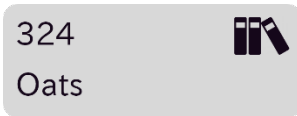
Not registered	Measurement program registered	Preset program registered
		

## 6.5. Thermal Analysis Mode

Access method: [Home] > [Menu] > [Additional functions] > [Thermal analysis mode]

- The drying temperature and drying time can be programmed. Five levels of settings are available.

Setting	Available range	Default setting
Drying temperature 1 to 5	30 to 200°C (1°C increments)	100°C
Drying time 1 to 5	1 to 96 min (1 min increments)	5 min

- You can change the following settings.

Setting	Available range		Default setting	
	MS-74AT	MX-53AT	MS-74AT	MX-53AT
Measurement basis	Moisture content (wet basis)		Moisture content (wet basis)	
	Moisture content (dry basis, Atro)			
	Solid content			
	Ratio			
	Grams			
Minimum display during measurement	0.001~0.1 %	0.01~0.1 %	0.001 %	0.01 %
Minimum display in grams	0.0001~0.1 g	0.001~0.1 g	0.001 g	0.001 g

## CAUTION

- The measurement results of the thermal analysis mode are not recorded to the main unit and not displayed in the measurement history.
- For safety purposes, the high temperature setting is automatically lowered to 160°C if one hour elapses after heating starts.

## 6.6. Procedure for Measuring the Moisture Content (Simple Measurement with Automatic Measurement Start Enabled)

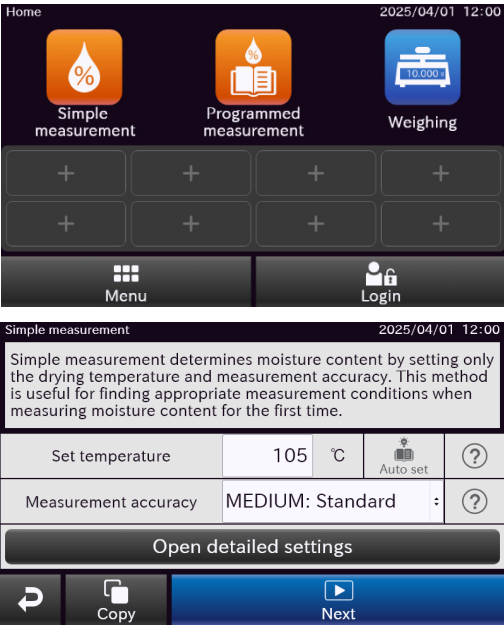
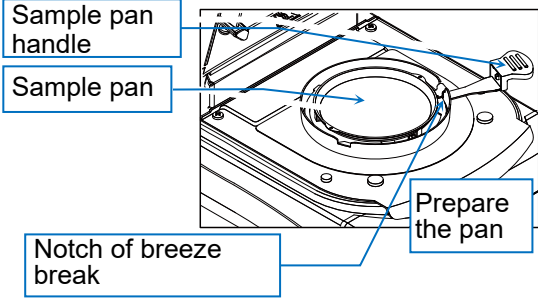

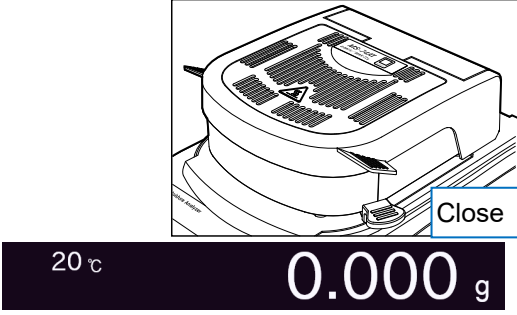
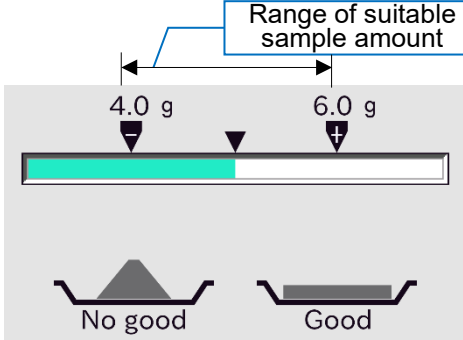
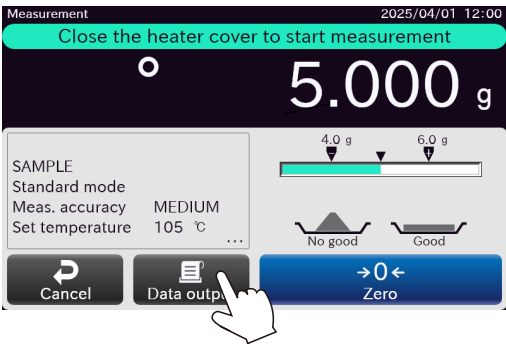
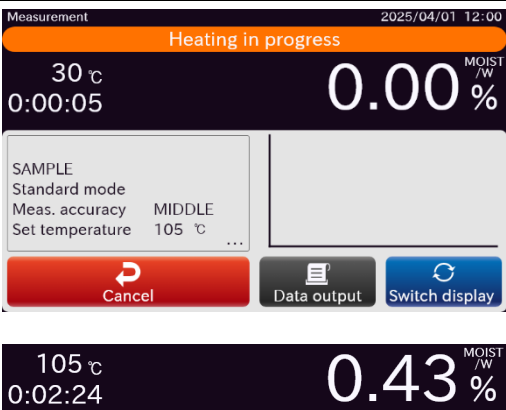
Step	Description	Operation
1.	Turn the power of the main unit on, then when the standby screen is displayed, press the <b>ON:OFF</b> key to display the home screen.	
2.	Touch the <b>Simple measurement</b> button to display the simple measurement screen. Set the drying temperature and measurement accuracy, then touch the <b>Next</b> button.	
3.	<p>Place the sample pan on the sample pan handle and load them on the pan holder.</p> <p><b>CAUTION</b></p> <ul style="list-style-type: none"> <li>Place the sample pan handle in the notch of the breeze break.</li> </ul>	

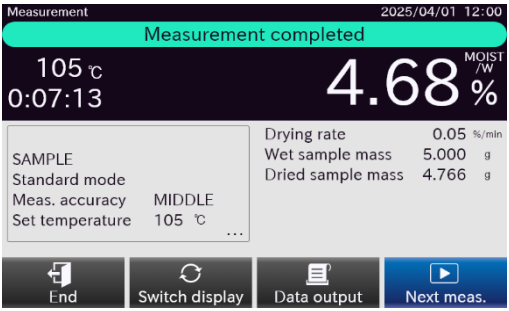
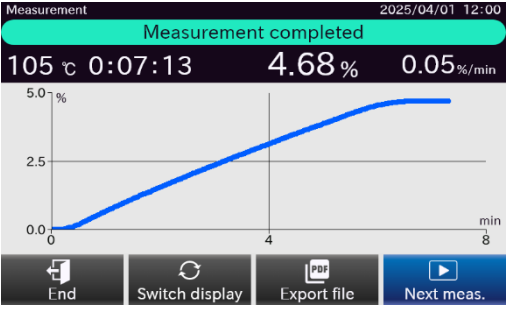
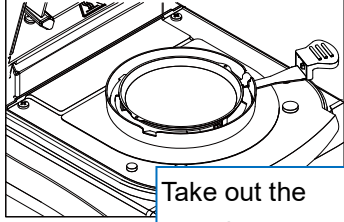
Step	Description	Operation
4.	<p>Close the heater cover.</p> <p>When the cover is closed, the mass display automatically resets to zero. (Avoid disturbance such as vibrations during measurement.)</p> <p>If the displayed mass deviates from zero, press the <b>Zero</b> button to reset it to zero.</p>	
5.	<p>Open the heater cover and load an appropriate amount of sample, using the level meter as a guide.</p> <p><b>CAUTION</b></p> <ul style="list-style-type: none"> <li>At least 0.1 g of sample is required.</li> <li>Make the sample as flat as possible.</li> </ul>	
Remarks	<p>You can press the <b>Data output</b> button to output (print) the displayed mass.</p>	 <p>Example output: ST,+0005.000 g</p>
6.	<p>Wait until the displayed mass stabilizes, then close the heater cover.</p> <p>Heating automatically starts when the cover is closed.</p> <p>The measured value changes according to the vaporization of the moisture in the sample.</p>	

Step	Description	Operation
7.	When the termination value is met (either the moisture content going below a certain value or heating continuing for a certain time), a buzzer sounds and measurement stops.	
Remarks	<p>You can perform the following operations on the result screen.</p> <p><b>Switch display</b> button Switches to the graph display.</p> <p><b>Data output</b> button Outputs (prints) the data. *Refer to "<a href="#">12.2. Example Measurement Result Output</a>"</p> <p><b>Export file</b> button Outputs a PDF report to a USB flash drive.</p> <p><b>Next meas.</b> button Starts measurement with the same program.</p> <p><b>End</b> button Returns to the home screen.</p>	 <p>Example output: ST,+00004.68 %</p>
8.	<p>Open the heater cover, hold the sample pan, then take out the sample.</p> <p><b>ADVICE</b></p> <ul style="list-style-type: none"> <li>The sample pan can be washed and reused.</li> </ul>	 <p>Take out the sample</p>

## 6.7. Weighing

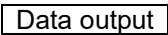
Access method: [Home] > [Weighing]

- This mode uses the moisture analyzer as a scale. It is useful for weighing entire samples before measurement.
- Weights are displayed in grams (g).
- You can press the  button to output the displayed value.
- You can press the  button to display the dedicated screen for this function. The available settings are as follows.

Setting	Available range		Description
	MS-74AT	MX-53AT	
Minimum display in grams	0.0001 g 0.001 g* 0.01 g 0.1 g	0.001 g* 0.01 g 0.1 g	Selects the smallest digit to display for weighing.
Comparator	Off* On		Enables/disables the comparator function. When enabled, the level meter is displayed on the weighing screen.
Upper limit value	0.0 g to 71.0 g (5.5 g*)	0.0 g to 51.0 g (5.5 g*)	Sets an upper limit for the comparator (in 0.1 g increments). Available when the comparator is on. A value that is lower than the lower limit cannot be set.
Lower limit value	0.0 g to 71.0 g (4.5 g*)	0.0 g to 51.0 g (4.5 g*)	Sets a lower limit for the comparator (in 0.1 g increments). Available when the comparator is on. A value that exceeds the upper limit cannot be set.

\*Default setting



## 7. Measurement Conditions

With simple measurement and programmed measurement, you can configure and save measurement conditions of your choice. By selecting a program, you can recall the saved measurement conditions. To perform moisture content measurement with the recalled measurement conditions, refer to "6. Measurement" to start measurement.

### 7.1. Overview of Measurement Conditions

#### 7.1.1. List of Measurement Conditions

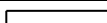
- The following list indicates the items that can be configured in the measurement conditions.
- For details on each item, refer to "7.2. Detailed Description of Measurement Conditions".

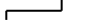
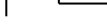
Measurement conditions	Setting value (available range)	
Program number	(1 to 300)	
Program ID	(maximum 16 characters)	Single-byte alphanumeric characters and symbols only
Program name	(maximum 20 characters)	Single-byte alphanumeric characters and symbols only
Image	Displayed when selecting the program	
Measurement mode	Standard mode Timer mode Custom mode	
Heating pattern	Standard	
	Ramp	
	Step	
	Quick	
Drying temperature	Temp	(30 to 200°C)
Temperature 1	Temp Step 1 <sup>*1</sup>	(30 to 200°C)
Temperature 2	Temp Step 2 <sup>*1</sup>	(30 to 200°C)
Drying time	Overall measurement time <sup>*1</sup>	(1 to 480 min)
Ramp time	Ramp time for ramp heating <sup>*1</sup>	(1 to 480 min)
Drying time for Temperature 1	Time for Temp Step 1 <sup>*1</sup>	(1 to 480 min)
Measurement accuracy <sup>*1</sup>	HIGH: Priority on accuracy MEDIUM: Standard LOW: Priority on measurement time	
Termination value <sup>*1</sup>	Termination value for the custom mode	(0.001 to 2%/min) <sup>*2</sup>
Sample mass setting <sup>*1</sup>	Measurement possible from 0.1 g Measurement possible within the range	
Upper limit of sample mass <sup>*1</sup>	(0 to 51 or 71 g) <sup>*2</sup>	
Lower limit of sample mass <sup>*1</sup>	(0 to 51 or 71 g) <sup>*2</sup>	
Measurement basis	Moisture content (wet basis) Moisture content (dry basis, Atro) Solid content Ratio Grams	

Measurement conditions	Setting value (available range)
Minimum display during measurement	Percentage (0.001 to 0.1%) <sup>*2</sup>
Minimum display in grams	Grams (0.0001 to 0.1 g) <sup>*2</sup>
Comparator	Off On
Upper limit value	Comparator upper limit value <sup>*1</sup> (0.0 to 999.9%)
Lower limit value	Comparator lower limit value <sup>*1</sup> (0.0 to 999.9%)
Preheating	Off On
Automatic measurement start	Off On
Glass fiber sheet	None Use one sheet: Cover the sample Use one sheet: Soak the sample Use two sheets: Sandwich the sample Use one filter paper: Soak the sample Use two filter papers: Sandwich the sample
Sample pretreatment	None Spread evenly Cut into small pieces Crush
Correction of measurement results	Off On
Correction value	(-9.999% to 9.999%) <sup>*2</sup>

<sup>\*1</sup> May not be able to be set, depending on the other settings. Refer to "[Available Measurement Conditions](#)" for details.

<sup>\*2</sup> The range of available values depends on the model.

---

## 7.1.2. How to Change the Measurement Conditions

---

- The applications that measurement conditions can be configured for and the configuration screens are indicated below.

For simple measurement                      Access method: [Home] > [Simple measurement] > [Open detailed settings]

For programmed measurement              Access method: [Home] > [Programmed measurement] > (select program)> [Edit]

## Available Measurement Conditions

- The available measurement conditions depend on the selected measurement mode.

Measurement condition	Measurement mode		
	Standard mode	Timer mode	Custom mode
Program ID	Yes		
Program name	Yes		
Image	Yes		
Heating pattern	Yes		
Drying temperature	The available items differ for each measurement mode and heating pattern. Refer to " <a href="#">7.2.6. Drying Temperature, Temperature 1, Temperature 2, Drying Time, Ramp Time, and Drying Time for Temperature 1</a> ".		
Temperature 1			
Temperature 2			
Drying time			
Ramp time			
Drying time for Temperature 1			
Measurement accuracy	Yes	No	No
Termination value	No	No	Yes
Sample mass setting	No	Yes	Yes
Upper limit of sample mass	No	Yes <sup>*1</sup>	Yes <sup>*1</sup>
Lower limit of sample mass	No	Yes <sup>*1</sup>	Yes <sup>*1</sup>
Measurement basis	Yes		
Minimum display during measurement	No	Yes	Yes
Minimum display in grams	No	Yes	Yes
Comparator	Yes		
Upper limit value	Yes <sup>*2</sup>		
Lower limit value	Yes <sup>*2</sup>		
Preheating	Yes		
Automatic measurement start	Yes		
Glass fiber sheet	Yes		
Sample pretreatment	Yes		
Correction of measurement results	Yes		
Correction value	Yes <sup>*3</sup>		

<sup>\*1</sup> Only available when [Sample mass setting] is set to [Measurement possible within the range].

<sup>\*2</sup> Only available when [Comparator] is set to [On].

<sup>\*3</sup> Only available when [Correction of measurement results] is set to [On].

### 7.1.3. Default setting

- The default measurement conditions are set as follows.

Measurement condition	Model	
	MS-74AT	MX-53AT
Program ID	SAMPLE	
Program name	SAMPLE	
Image	None	
Measurement mode	Standard mode	
Heating pattern	Standard	
Drying temperature	105°C	
Temperature 1	105°C	
Temperature 2	105°C	
Drying time	10 min	
Ramp time	5 min	
Drying time for Temperature 1	5 min	
Measurement accuracy	MEDIUM: Standard	
Termination value	0.02%/min	0.05%/min
Sample mass setting	Measurement possible from 0.1 g	
Upper limit of sample mass	6 g	
Lower limit of sample mass	4 g	
Measurement basis	Moisture content (wet basis)	
Minimum display during measurement	0.001%	0.01%
Minimum display in grams	0.001 g	0.001 g
Comparator	Off	
Upper limit value	10%	
Lower limit value	9%	
Preheating	Off	
Automatic measurement start	On	
Glass fiber sheet	None	
Sample pretreatment	None	
Correction of measurement results	Off	
Correction value	0.000%	0.00%

## 7.2. Detailed Description of Measurement Conditions

- This section describes details of the measurement conditions.

---

### 7.2.1. Program ID

---

- The string used for identification when sending data to a printer or computer.
- A 16 character name can be set for the parameter.
- The available characters are as follows.  
Single-byte letters, single-byte numbers, and single-byte symbols

---

### 7.2.2. Program name

---

- A 20 character name can be set for the parameter.
- The available characters are as follows.
- Single-byte letters, single-byte numbers, and single-byte symbols

---

### 7.2.3. Image

---

- This function displays an image to enable intuitive program selection.
- You can import an image file from a USB flash drive and display it on the program selection screen.

#### How to Use

- Save the image file you want to display to a USB flash drive. The supported file formats are JPEG, PNG, and BMP.
- Connect the USB flash drive to the USB port of the moisture analyzer.
- You can press the  button to display a list of the image files on the USB flash drive. Select the image to import, then press the  button.

#### CAUTION

- Take care with the size and resolution of the image file. It may take a long time to import a file that is too large.
- If the imported image is not displayed with the correct orientation, you can press the rotation button () to rotate the image by 90 degrees.
- Confirm that the USB flash drive is formatted correctly.
- An image cannot be set with simple measurement.

## 7.2.4. Measurement Modes



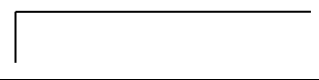
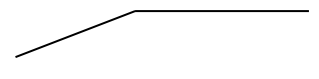
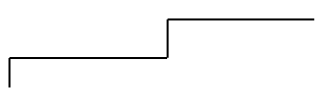
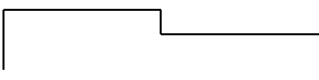

Mode name	Description of operation
Standard mode	The standard mode for configuring the main parameters only. The [Measurement accuracy] setting automatically sets [Upper limit of sample mass] and [Lower limit of sample mass], [Termination value], [Minimum display during measurement], and [Minimum display in grams]. (Refer to "7.2.7. Measurement accuracy".)
Timer mode	The mode for configuring the drying time. (1 to 480 min)
Custom mode	Enables the user to configure detailed measurement conditions such as the measurement termination value.

## 7.2.5. Heating pattern

Heating pattern name	Temperature change	Description
Standard		Maintains the set temperature.
Ramp		Gradually raises the temperature over time until the set temperature is reached. Then maintains the set temperature.
Step		Enables you to set two temperatures. Set the two temperatures and the time to maintain the first temperature.
Quick		Performs heating for approx. three minutes at 200°C. Then maintains the set temperature.

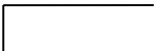
## 7.2.6. Drying Temperature, Temperature 1, Temperature 2, Drying Time, Ramp Time, and Drying Time for Temperature 1

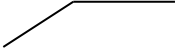
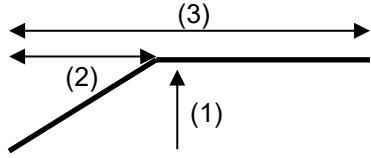
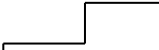
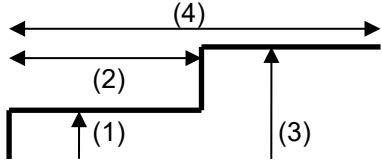
- Arbitrary values can be set for the drying temperature and time.  
Temperature: 30 to 200°C (1°C increments)  
Time: 1 to 480 min (1 min increments)
- The available and required temperature and time values differ according to the measurement mode and heating pattern. The table below indicates the available temperatures and times for each condition.

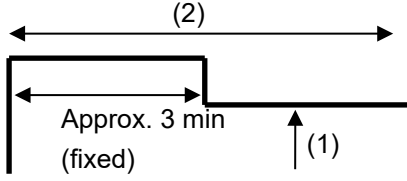
Heating pattern	Available temperature and time
Standard heating 	(1) Drying temperature (2) Drying time*1 
Ramp heating 	(1) Drying temperature (2) Ramp time (3) Drying time*1 
Step heating 	(1) Temperature 1 (2) Drying time for Temperature 1*2 (3) Temperature 2 (4) Drying time*1 
Quick heating 	(1) Drying temperature (2) Drying time*1 

\*1 Only available when the measurement mode is set to the timer mode.

\*2 If the (2) Drying time for Temperature 1 exceeds the (4) Drying time, measurement ends at the (4) Drying time.

### 7.2.7. Measurement accuracy

- This can only be selected with the standard measurement mode.
- One of three levels (HIGH: Priority on accuracy, MEDIUM: Standard, or LOW: Priority on measurement time) can be selected for the measurement accuracy of the moisture analyzer.
- [Termination value], [Upper limit of sample mass], [Lower limit of sample mass], [Minimum display during measurement], and [Minimum display in grams] are automatically set according to the measurement accuracy.
- The selected values are as follows.

Model	Measurement conditions	Measurement accuracy		
		Priority on accuracy	Standard	Priority on measurement time
		HIGH	MEDIUM	LOW
MS-74AT	Termination value	0.01%/min	0.02%/min	0.10%/min
	Upper limit of sample mass	11.0 g	6.0 g	1.5 g
	Lower limit of sample mass	9.0 g	4.0 g	0.5 g
	Minimum display during measurement	0.001%	0.001%	0.01%
	Minimum display in grams	0.001 g		
MX-53AT	Termination value	0.02 %/min	0.05 %/min	0.50 %/min
	Upper limit of sample mass	11.0 g	6.0 g	1.5 g
	Lower limit of sample mass	9.0 g	4.0 g	0.5 g
	Minimum display during measurement	0.01%	0.01%	0.1%
	Minimum display in grams	0.001 g		

### 7.2.8. Termination value

- This can only be selected with the custom mode.
- Because the moisture decreases as the sample dries, the drying rate per unit time decreases.
- If the drying rate over one minute is lower than the set value, heating is deemed to have ended and measurement finishes.
- The available settings are as follows.

		Available range of settings	
		MS-74AT	MX-53AT
2.00	%/min	↑	↑
1.00	%/min		
0.50	%/min		
0.20	%/min		
0.10	%/min		
0.05	%/min		Default setting
0.02	%/min	Default setting	↓
0.01	%/min		
0.005	%/min		
0.002	%/min		
0.001	%/min	↓	

---

## 7.2.9. Configuring the Sample Mass

---

Sample mass setting	Description
Measurement possible from 0.1 g	Measurement is possible when a sample mass of at least 0.1 g is loaded.
Measurement possible within the range	Measurement cannot be performed unless the sample mass is within the range set in " <a href="#">7.2.10. Lower limit and upper limit of sample mass</a> ".

## 7.2.10. Lower limit and upper limit of sample mass

- The sample mass can only be configured with the timer mode or custom mode.
- Set the upper limit value and lower limit value for loading the sample. The amount to load can be adjusted according to the displayed level meter.
- When [Sample mass setting] is set to [Measurement possible within the range], heating cannot be started if the sample mass is outside the range of setting values.
- The upper limit cannot be set to a value lower than the lower limit. The lower limit also cannot be set to a value higher than the upper limit.

Example level meter display when the upper limit is set to 6 g and the lower limit is set to 4 g

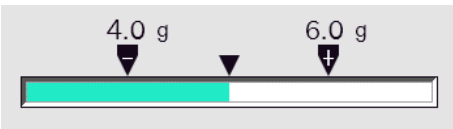
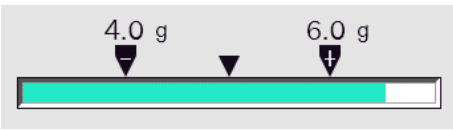
Sample amount	Level meter display
Lower than the set lower limit Approx. 2 g	
Within range of set values Approx. 5 g	
Higher than the set upper limit Approx. 7 g	

## 7.2.11. Measurement basis

Unit	Calculation formula of displayed value	Display
Moisture content (wet basis) <sup>*1</sup>	$\frac{W - D}{W} \times 100$	% MOIST /W
Moisture content (Atro) (dry basis, Atro) <sup>*2</sup>	$\frac{W - D}{D} \times 100$	% MOIST /D
Solid content	$\frac{D}{W} \times 100$	% RATIO D/W
Ratio <sup>*2</sup>	$\frac{W}{D} \times 100$	% RATIO W/D
Grams <sup>*3</sup>	-	g

W: Wet sample mass    D: Dried sample mass

\*1 Default setting

\*2 If the dried sample mass decreases and the measured value exceeds 999%, operation automatically stops because the measurement results cannot be calculated correctly.

\*3 The drying rate (%/min) and graph display are the moisture content (wet basis).

## 7.2.12. Minimum display during measurement: Minimum display in grams

- The available minimum selectable for each model is indicated in the table below.

Model	Minimum displayed	
	% (percentage)	g (grams)
MS-74AT	0.001 %	0.0001 g
	0.01 %	0.001 g
	0.1 %	0.01 g
		0.1 g
MX-53AT	0.01 %	0.001 g
	0.1 %	0.01 g
		0.1 g

## 7.2.13. Comparator Upper Limit/Lower Limit

- By enabling the comparator function, the moisture content can be compared at three levels.
- You can set an upper limit and lower limit for the comparator that are between 0.0 to 999.9 %.
- The comparator result is displayed during measurement and on the screen when measurement stops, and is appended to the measurement result that is output externally.
- To display the level meter during measurement, press the Switch display button.

### Example judgment formulas and indicators

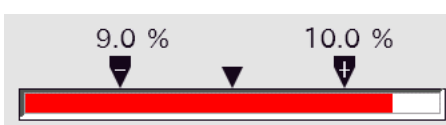
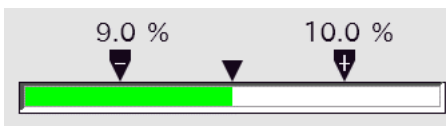
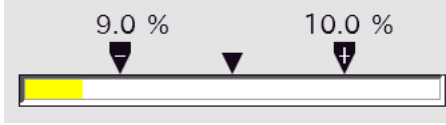
Judgment formula	Judgment result	Example level meter display
Upper limit < moisture content	HI	
Lower limit ≤ moisture content ≤ upper limit	OK	
Moisture content < lower limit	LO	

## CAUTION

- The level meter is displayed only when the comparator is enabled, by pressing the Switch display button.

## 7.2.14. Preheating

Refer to "[5.2.3. How to Use the Preheat Function](#)".

---

## 7.2.15. Automatically Starting Measurement

---

- By enabling the automatic measurement start function, the tare deduction and start operations for measurement can be performed simply by operating the heater cover. This enables efficient measurement without the need to perform touch operations on the screen.
- Disable the function to manually perform tare deduction and start operations.

---

## 7.2.16. Glass Fiber Sheet

---

- By enabling this function, instructions for using a glass fiber sheet or filter paper are displayed on the screen when performing measurement.
- For information on using and configuring glass fiber sheets and filter paper, refer to "[5.2.4. Using a Glass Fiber Sheet](#)".
- The "[8.3. Sample Pretreatment Guide](#)" in the measurement guide is a function that proposes the optimal glass fiber sheet usage method based on the sample properties.

---

## 7.2.17. Sample Pretreatment

---

- By enabling this function, instructions for pretreating the sample are displayed on the screen when performing measurement.
- The "[8.3. Sample Pretreatment Guide](#)" in the measurement guide is a function that proposes the optimal pretreatment method based on the sample properties.
- The instructions that are actually displayed are as follows.

Sample pretreatment	Instruction when placing the sample	Use
None	None	Used for a sample that does not require special pretreatment.
Spread evenly	Spread the sample evenly	Suitable for powder or paste samples. By spreading the sample evenly, heating is performed evenly.
Cut into small pieces	Cut the sample into small pieces	Suitable for sheet-like or fiber-like samples. By cutting the sample into small pieces, heating is performed evenly.
Crush	Crush the sample	Suitable for samples such as large clumps, beans, or seeds. Samples such as these are prone to temperature differences between the surface and interior, so crushing them to increase the surface area enables heating to be performed evenly.

---

## 7.2.18. Correction of measurement results

---

- The result of measuring the moisture content can be corrected.
- This function is intended for use when a moisture analyzer made by another manufacturer is replaced by this instrument and the measurement results do not match previous values due to differences in model or measurement method, even when the measurement conditions and sample conditions are the same.
- This function is used to correct measurement results when it is necessary to maintain consistency with past measurement results.

Model	Result correction value
MS-74AT	-9.999% to 9.999%
MX-53AT	-9.99% to 9.99%
Default setting (no correction)	0%

### Calculation formula

The displayed moisture content equals the moisture content that is actually measured plus the correction value.

## **CAUTION**

- If the measured value is negative, 0% is displayed for the moisture content.
- Correction is not performed if the correction value is 0% or moisture content correction is disabled.
- The correction value is appended to the GLP output and measurement history output.

## 8. Measurement Guide

Access method: [Home] > [Menu] > [Measurement guide]

The measurement guide includes functions useful when deciding the measurement conditions of a program. The functions determine the recommended measurement conditions. The judgment result can be set as the measurement conditions for simple measurement and programmed measurement.

The measurement conditions that can be configured from each function are indicated below.

Measurement guide function	Overview	Available measurement conditions
Automatic Drying Temperature Judgment (RsTemp)	This function performs test heating to automatically determine the estimated drying temperature.	Drying temperature <sup>*1*2</sup>
Sample mass calculation tool	Enter the expected moisture content of the sample to calculate the required sample mass. You can also measure the actual moisture content and calculate the sample mass from the result.	Upper limit of sample mass Lower limit of sample mass <sup>*3</sup>
Sample Pretreatment Guide	Proposes whether to use a glass fiber sheet and perform sample pretreatment according to the sample properties.	Glass fiber sheet Sample pretreatment
Determination of Drying Time	This function performs test heating to determine the estimated drying time for the timer mode.	Drying time <sup>*2*4*5</sup>
Measurement examples	Displays a list of the moisture content and measurement conditions of the samples measured with the unit.	

\*1 [Temperature 1] and [Temperature 2] are also set in the same manner.

\*2 [Heating pattern] is automatically set to [Standard].

\*3 [Measurement mode] is automatically set to [Custom mode].

\*4 [Measurement mode] is automatically set to [Timer mode].

\*5 [Drying temperature], [Temperature 1], and [Temperature 2] are set to the determined temperature.

### 8.1. Automatic Drying Temperature Judgment (RsTemp)

Access method 1: [Home] > [Menu] > [Measurement guide] > [Optimum temperature search (RsTemp)]

Access method 2: [Home] > [Simple measurement] > [Drying temperature] > [Auto set]

Access method 3: [Home] > [Programmed measurement] > [Edit] > [Drying temperature] > [Auto set]

- This function automatically determines the recommended drying temperature based on the drying rate when performing test heating at multiple temperatures on a sample for which the appropriate drying temperature is unknown.
- The moisture content and drying rate of the sample are graphed in real-time.
- After test heating, the drying temperature is rated on a six-level scale, from A to F. A temperature rated A can be set as the drying temperature for the measurement program (to save the set temperature, press the  button on the results screen).
- By default, it takes about 30 minutes for the temperature to be determined. Test heating is performed for five minutes a time at 100°C, 120°C, 140°C, 160°C, 180°C, and 200°C.
- The starting drying temperature, temperature increase per step, and measurement time per step can be configured.

Setting	Available range	Default setting <sup>*1</sup>
Starting temperature	30 to 200°C (1°C increments) <sup>*2</sup>	100°C
Step temperature	1 to 34°C (1°C increments) <sup>*2</sup>	20°C
Step time	1 to 80 min (1 min increments)	5 min

- \*1 You can press the  button to restore the default setting values.
  - \*2 The final temperature cannot be set to exceed 200°C. The available range for the starting temperature and step temperature differ according to the settings.
- You can press the  button on the results screen to output the results. For an example of the output result, refer to "[12.8. Output for Automatic Drying Temperature Judgment \(RsTemp\)](#)".
  - You can also touch the  button to output a PDF report to a USB flash drive. For an example of the output result, refer to "[13.3. Automatic Drying Temperature Judgment \(RsTemp\) Report](#)".
  - You can connect to a computer and use the RsTemp function of the WinCT-Moisture software to perform test heating in the same manner. (Refer to "[17.5.2. RsTemp Software for Automatic Drying Temperature Detection](#)".)

## CAUTION

- The product determines the recommended drying temperature based on the measurement and calculated result, but the recommended temperature may not be able to be appropriately determined, depending on the sample type and amount.
- When deciding the drying temperature of the sample, also observe the state of the sample over time (whether it melts, burns, smells, or disintegrates) and use that information to ultimately help decide the optimal drying temperature.
- The measurement conditions are fixed to the default values and cannot be changed.
- For safety purposes, the high temperature setting is automatically lowered to 160°C if one hour elapses after heating starts.

## 8.2. Sample mass calculation tool

Access method 1: [Home] > [Menu] > [Measurement guide] > [Sample mass calculation tool]

Access method 2: [Home] > [Simple measurement] > [Open detailed settings] > [Upper limit of sample mass] or [Lower limit of sample mass] > [Auto set]<sup>\*1</sup>

Access method 3: [Home] > [Programmed measurement] > [Edit] > [Upper limit of sample mass] or [Lower limit of sample mass] > [Auto set]<sup>\*1</sup>

- \*1 Only displayed when the timer mode or custom mode is set for the measurement mode.
- Enter the expected moisture content of the sample to calculate the required sample mass for accurately measuring the sample.
  - You can also measure the actual moisture content and calculate it from the result.
  - The calculated sample mass can be set in the measurement conditions (upper limit of sample mass and lower limit of sample mass) for the measurement program (to save the set temperature, press the  button on the results screen).
  - You can change the following settings.

Setting	Available range	Description
Sample mass calculation method	Enter the expected moisture content	From the range of expected moisture content that is selected, display the required sample mass. Press the <b>Next</b> button to switch to the screen for entering the expected moisture content.
	Measure the moisture content	You can also measure the actual moisture content and display the required sample mass from the result. Press the <b>Next</b> button to switch to the screen for configuring the drying temperature and start measurement.
Expected moisture content	$M \leq 0.1\%$ $0.1\% < M \leq 0.2\%$ $0.2\% < M \leq 0.5\%$ $0.5\% < M \leq 1.0\%$ $1.0\% < M$ Unknown	When [Enter the expected moisture content] is selected as the sample mass calculation method, select the range of expected moisture content (where M is the moisture content). If you are not sure of the expected moisture content, select [Unknown].
Set temperature	30°C to 200°C	When [Measure the moisture content] is selected as the sample mass calculation method, configure the drying temperature.

- For information on handling the sample, refer to "5.2.1. Handling Samples".
- The required sample mass is usually that where the moisture content included in the sample will become about 20 mg.
- When saving to the measurement program, the upper limit of sample mass and lower limit of sample mass are set to the calculated sample mass +1 g and -1 g, respectively.

Available range (where M is the moisture content)	Required sample mass	Upper limit of sample mass	Lower limit of sample mass
$M \leq 0.1\%$	25.0 g	26.0 g	24.0 g
$0.1\% < M \leq 0.2\%$	20.0 g	21.0 g	19.0 g
$0.2\% < M \leq 0.5\%$	10.0 g	11.0 g	9.0 g
$0.5\% < M \leq 1.0\%$	5.0 g	6.0 g	4.0 g
$1.0\% < M$	2.0 g	3.0 g	1.0 g
Unknown	25.0 g	26.0 g	24.0 g

## CAUTION

- These values are for reference purposes only. They do not guarantee accurate measurement.
- Information may differ depending on the sample to measure.
- When the upper limit of sample mass and lower limit of sample mass are set in the measurement program, the measurement mode is automatically set to the custom mode.
- When measuring the moisture content, the measurement conditions other than the set temperature are fixed to the default values and cannot be changed.

## 8.3. Sample Pretreatment Guide

Access method 1: [Home] > [Menu] > [Measurement guide] > [Sample pretreatment guide]

Access method 2: [Home] > [Simple measurement] > [Open detailed settings] > [Glass fiber sheet] or [Sample pretreatment] > [Auto set]

Access method 3: [Home] > [Programmed measurement] > [Edit] > [Glass fiber sheet] or [Sample pretreatment] > [Auto set]

- Proposes whether to use a glass fiber sheet and perform sample pretreatment according to the sample properties.
- The proposed result can be set in the measurement conditions (glass fiber sheet and sample pretreatment) for the measurement program (to save the set temperature, press the  button on the results screen).
- For information on glass fiber sheets, refer to "[5.2.4. Using a Glass Fiber Sheet](#)".
- For information on sample pretreatment, refer to "[7.2.17. Sample Pretreatment](#)".

### Operation Method

- Three questions are displayed regarding the sample properties. Select the properties that correspond to the sample. Examples of typical samples are indicated below.

		Coffee beans	Milk	Toothpaste
Question	Property 1	Solid	Liquid	Paste
	Property 2	Lumpy	Forms a film on the surface when heated	Does not denature when heated
	Property 3	Dark in color and easily scorched	Not easily scorched	Not easily scorched
Suggestion	Glass fiber sheet	Use one sheet: Cover the sample	Use one filter paper: Soak the sample	None
	Sample pretreatment	Crush	None	Spread evenly

### CAUTION

- This information is for reference purposes only. It does not guarantee accurate measurement.
- Not all sample properties are covered here.
- Information may differ depending on the sample to measure.

## 8.4. Determination of Drying Time

Access method 1: [Home] > [Menu] > [Measurement guide] > [Determination of drying time]

Access method 2: [Home] > [Simple measurement] > [Open detailed settings] > [Drying time] > [Auto set]<sup>\*1</sup>

Access method 3: [Home] > [Programmed measurement] > [Edit] > [Drying time] > [Auto set]<sup>\*1</sup>

<sup>\*1</sup> Only displayed when the timer mode is set for the measurement mode.

- This function determines the recommended drying time based on the drying rate when performing test heating on a sample for which the appropriate drying time is unknown.
- The moisture content and drying rate of the sample are graphed in real-time.
- After test heating, the optimal drying time is displayed as a three-level measurement accuracy. The drying time selected according to the required accuracy can be set for the measurement program (to set it, press the **Set** button on the results screen).
- By default, it takes a maximum of 30 minutes for the temperature to be determined.
- During test heating, the product automatically checks the drying rate (%/min). The times where the drying rate reaches three levels of measurement accuracy are deemed to the optimal drying times.
- The drying rate (%/min) corresponding to the three levels of measurement accuracy are as follows.

Measurement accuracy	Drying rate	Description
★	0.100%/min	Corresponds to the "LOW: Priority on measurement time" measurement accuracy termination value of the MS-74AT
★★	0.020%/min	Corresponds to the "MEDIUM: Standard" measurement accuracy termination value of the MS-74AT
★★★	0.010%/min	Corresponds to the "HIGH: Priority on accuracy" measurement accuracy termination value of the MS-74AT

- You can change the following settings.

Setting	Available range	Default setting
Drying temperature	30 to 200°C (1°C increments)	105°C
Maximum measurement time	10/30/60/120 min	30 min

### CAUTION

- The product determines the recommended drying temperature based on the measurement and calculated result, but the recommended temperature may not be able to be appropriately determined, depending on the sample type and amount.
- When deciding the drying time of the sample, also observe the state of the sample over time (whether it melts, burns, smells, or disintegrates) and use that information to ultimately help decide the optimal drying time.
- The measurement conditions are fixed to the default values and cannot be changed.
- If the drying rate (%/min) does not reach a measurement accuracy by the maximum measurement time, the optimal drying time is not displayed on the results screen and also not set for the measurement program.
- For safety purposes, the high temperature setting is automatically lowered to 160°C if one hour elapses after heating starts.

## 8.5. Measurement Examples

Access method: [Home] > [Menu] > [Measurement guide] > [Measurement examples]

- A list of the moisture content and measurement conditions of the samples actually measured with the unit are displayed.
- More than 100 samples equivalent to the preset programs are displayed.
- The items of the table are described below.

Item	Description
Category	The sample category. Such as household goods, food, pharmaceuticals, or plastics.
Sample name	The sample name.
Sample mass	The mass of the sample used for measurement.
Measurement mode	The measurement mode set when measuring.
Termination value	The termination value set for measurement.
Set temperature	The temperature set when measuring.
Meas. time	The time taken to perform measurement.
Moisture content (average value)	The average value of the measurement result.
Moisture content (reproducibility)	The reproducibility of the measurement result. (Standard deviation: $\sigma$ )
Moisture content (variation coefficient)	The variation coefficient of the measurement result. (Reproducibility / average value) $\times 100$
Remarks	Sample pretreatment, use of glass fiber sheet, and other information.

### CAUTION

- These values are for reference purposes only. Even when performing measurement with the same conditions, results may vary.
- Information may differ depending on the sample to measure.

## 9. Plastic Measurement Guide

Access method: [Home] > [Menu] > [Plastic measurement guide]

The plastic measurement guide configures the sample mass, drying temperature, and drying time for measuring resin (plastic) with a low moisture content of 1% or less. This function uses the functions of the measurement guide ("8. Measurement Guide") to determine the recommended measurement conditions. The judgment result can be set as the measurement conditions for programmed measurement.

The plastic measurement guide involves three steps.

Step	Measurement guide function	Overview	Available measurement conditions
1	Sample mass calculation tool	Enter the expected moisture content of the sample to calculate the required sample mass. You can also measure the actual moisture content and calculate the sample mass from the result.	Upper limit of sample mass Lower limit of sample mass <sup>*1</sup>
2	Plastic Drying Temperature Judgment (PITemp)	This function performs test heating to automatically determine the estimated drying temperature.	Drying temperature <sup>*2*3</sup>
3	Determination of Drying Time	This function performs test heating to determine the estimated drying time for the timer mode.	Drying time <sup>*4</sup>

\*1 [Measurement mode] is automatically set to [Custom mode].

\*2 [Temperature 1] and [Temperature 2] are also set in the same manner.

\*3 [Heating pattern] is automatically set to [Standard].

\*4 [Measurement mode] is automatically set to [Timer mode].

### Operation Method

- Press the  button, then start the operation from step 1.
- Refer to the next page and beyond for details on each step. Refer to the following items for details on each step.
  - Step 1: "8.2. Sample mass calculation tool"
  - Step 2: "9.1. Plastic Drying Temperature Judgment (PITemp)"
  - Step 3: "9.2. Determination of Drying Time (for the Plastic Measurement Guide)"
- Each step can be omitted by pressing the  button.
- The drying temperature in step 3 is the temperature determined in step 2 (if step 2 is skipped, the value is not changed).
- When step 3 is completed or skipped, the  button is displayed. To save the judgment result to the measurement conditions, select the program to save on the program selection screen.

### CAUTION

- These values are for reference purposes only. They do not guarantee accurate measurement.
- The judgment result can only be set for programmed measurement and cannot be set for simple measurement.
- The measurement conditions of skipped steps are not saved.

## 9.1. Plastic Drying Temperature Judgment (PITemp)

- Plastic drying temperature judgment (PITemp) can only be executed with the plastic measurement guide function.
- It involves test heating of resin pellets with an unknown appropriate drying temperature at multiple temperatures, visually checking for state changes such as melting, and determining the drying temperature where there is no change.
- The moisture content and drying rate of the sample are graphed in real-time.
- After test heating, the determined temperature can be set as the drying temperature for the measurement program (to save the set temperature, press the **Set** button on the results screen).
- By default, it takes about 30 minutes for the temperature to be determined. Test heating is performed for five minutes a time at 100°C, 120°C, 140°C, 160°C, 180°C, and 200°C.
- The starting drying temperature, temperature increase per step, and measurement time per step can be configured.

Setting	Available range	Default setting <sup>*1</sup>
Starting temperature	30 to 200°C (1°C increments) <sup>*2</sup>	100°C
Step temperature	1 to 34°C (1°C increments) <sup>*2</sup>	20°C
Step time	1 to 80 min (1 min increments)	5 min

\*1 You can press the **Initialization** button to restore the default setting values.

\*2 The final temperature cannot be set to exceed 200°C. The available range for the starting temperature and step temperature differ according to the settings.

You can press the **Data output** button on the results screen to output the results. For an example of the output result, refer to "[12.9. Output for Plastic Drying Temperature Judgment \(PITemp\)](#)".

## 9.2. Determination of Drying Time (for the Plastic Measurement Guide)

- The basic operations are the same as for "[8.4. Determination of Drying Time](#)".
- The drying rate (%/min) corresponding to the three levels of measurement accuracy changes as follows.

Measurement accuracy	Drying rate
★	MS-74AT: 0.010%/min MX-53AT: 0.050%/min
★★	MS-74AT: 0.005%/min MX-53AT: 0.010%/min
★★★	MS-74AT: 0.001%/min MX-53AT: 0.005%/min

## 10. Check/Adjustment

This section describes the function tests included in the product for checking operation and the sensitivity adjustment for the weight sensor and drying temperature.

### 10.1. Function Tests and Adjustment Modes

- The product contains the following function tests and sensitivity adjustment modes.

Name	Description
Daily check	When using the moisture analyzer, check the required minimums and confirm that there are no problems.
Test sample measurement	Uses a test sample (sodium tartrate dihydrate and substances for moisture analyzer inspection) to check whether moisture content measurement is performed correctly.
Test sample measurement history	Displays the measurement results of the test sample.
Self-check function	Confirms that the heater is operating.
Weight sensor sensitivity adjustment	Adjusts the sensitivity of the weight sensor.
Heater temperature adjustment	Adjusts the drying temperature.

### 10.2. Daily Check

Access method: [Home] > [Menu] > [Check/adjustment] > [Daily check]

- The daily check involves checking the required minimums and confirming that there are no problems, when using the moisture analyzer. Although this depends on the management level of the moisture analyzer, we recommend that this check is performed every day before starting work.
- The items to check are as follows.

Item to check	Description
Checking the surrounding environment	Confirm that there are no flammable objects in the vicinity of the product and no objects on the heater cover.
Checking the exterior and heater section	Confirm that the moisture analyzer main unit is not damaged and that the halogen lamp and glass housing are not dirty. If the glass housing is dirty, it may not be able to heat properly. For information on cleaning, refer to " <a href="#">19.1. Cleaning the Heater</a> ".
Checking the sample pan	Make sure to place the breeze break, pan holder, sample pan, and sample pan handle are positioned correctly.
Checking the weight and temperature sensors	The moisture analyzer automatically checks the state of the weight sensor and temperature sensor. Avoid disturbance such as vibrations or wind during the check.

- Check the items, and press the **Confirmed** button if there is no problem.
- If you did not check the items or there was a problem, press the skip button.
- Press the **Show results** button on the last item to display a list of the test results.
- The results can be output at the end of the daily check. For an example of the output result, refer to "[12.6. Output for Daily Check](#)".
- However, if [Notification when display is on] is enabled, the display switches to the daily check start screen when you press the **ON:OFF** key or touch the screen on the standby screen.

## 10.3. Test Sample Measurement

Access method: [Home] > [Menu] > [Check/adjustment] > [Test sample measurement]

- Uses a test sample (sodium tartrate dihydrate) to check whether moisture content measurement is performed correctly.
- The measurement conditions are set in advance and cannot be changed.
- By enabling GLP output in the settings, you can touch the **Data output** button on the result screen to output the results. For an example of the output result, refer to "[12.7. Output for Test Sample Measurement](#)".
- You can also touch the **Export file** button to output a PDF file to a USB flash drive. For an example of the output result, refer to "[13.2. Test Sample Measurement Report](#)".

### 10.3.1. Performing a Function Check with Sodium Tartrate Dihydrate

- Sodium tartrate dihydrate ( $\text{Na}_2\text{C}_4\text{H}_4\text{O}_6 \cdot 2\text{H}_2\text{O}$ ) can be used for checking the performance of the moisture analyzer. Sodium tartrate includes 15.66% moisture in theory but this value differs according to how the substance is stored.
- The measurement conditions are fixed to the following values.

Measurement conditions	Set value
Measurement mode	Standard mode
Heating pattern	Standard
Temp	160°C
Lower limit and upper limit of sample mass	4.0 to 6.0 g
Measurement basis	Moisture content (wet basis)
Minimum displayed (%)	Minimum displayed for each model
Minimum displayed (g)	Minimum displayed for each model
Comparator upper limit and lower limit	15.4 to 16.0%

## CAUTION

- Sodium tartrate is also used as a food additive, but may irritate the eyes and nose. If it gets on your skin, wash it away with water.
- Dispose of the sodium tartrate after measurement as burnable waste. It cannot be reused.
- If the sample pan is hot before measurement starts, measurement error may occur.
- Sodium tartrate is included with the MS-74AT/MX-53AT.

### 10.3.2. Test Sample Measurement History

Access method: [Home] > [Menu] > [Check/adjustment] > [Test sample measurement history]

- Displays the measurement results of the test sample.
- Up to 3,000 sets of data can be recorded along with "[14. Measurement History](#)". If the number of sets exceeds 3,000, the oldest data is deleted.

## 10.4. Self-Check Function

Access method: [Home] > [Menu] > [Check/adjustment] > [Self-check function]

- The self-check function is used to check the operation of the moisture analyzer. This inspection checks the moisture analyzer for problems when the correct measurement results are not obtained or an operation error is expected.
- A light is turned on while the function is operating, and temperature control is also checked.
- The check normally finishes in about one minute.

### CAUTION

- Do not place flammable objects in the vicinity of the product, as with regular measurement.
- Do not place objects on the heater cover.

## 10.5. Weight Sensor Sensitivity Adjustment

Access method: [Home] > [Menu] > [Check/adjustment] > [Weight sensor sensitivity adjustment]

- You can use the 20 g or 50 g weight.
- It is recommended that you use the 20 g weight for sensitivity adjustment (AD1603-20F1).
- You can press the  button to output the sensitivity adjustment record. For information on the output result, refer to "[12.4. Weight Sensor Output for Sensitivity Adjustment](#)".

### CAUTION

- Avoid disturbance such as vibrations or wind during sensitivity adjustment. Sensitivity adjustment may not be able to be performed if there is disturbance.
- Because a tall weight may touch the top glass of the heater, use a short weight (20 g weight) where possible. When you have no choice but to use a tall weight, perform sensitivity adjustment with the heater cover open. Ensure that there is no disturbance such as wind.

## 10.6. Heater Temperature Adjustment

Access method: [Home] > [Menu] > [Check/adjustment] > [Heater temperature adjustment]

- Place the sensor of the optional temperature adjustment kit (AX-MXA-43) on the pan holder, measure the temperature of the sample pan part, then input the measurement result to the moisture analyzer. This process is performed at 100°C and 160°C.
- Heating is performed at both temperatures for 20 minutes. A buzzer sounds when 20 minutes have elapsed.
- Enter the actual temperature displayed on the thermometer in [Temperature measured by the thermometer].
- If five minutes elapse without a temperature input since the buzzer sounded, the process times out and is canceled. You can press the **OK** button to return to the home screen.
- When you input the temperature, if measurement temperature 1 has just finished, press the **Start** button to start the measurement for measurement temperature 2. If measurement temperature 2 has just finished, press the **Confirm** button to switch to the result screen.
- You can press the **Data output** button to output the heater temperature adjustment record. For information on the output result, refer to "12.5. Output for Heater Temperature Adjustment".
- For information on operating the temperature display, refer to the instruction manual that came with the temperature adjustment kit.

### CAUTION

- When installing the temperature adjustment kit, ensure that the wire of the temperature sensor is not pushed by the glass inside the heater unit, as it can cause the sensor of the temperature adjustment kit to lift up. Fold back the cable protruding from the sensor as required.

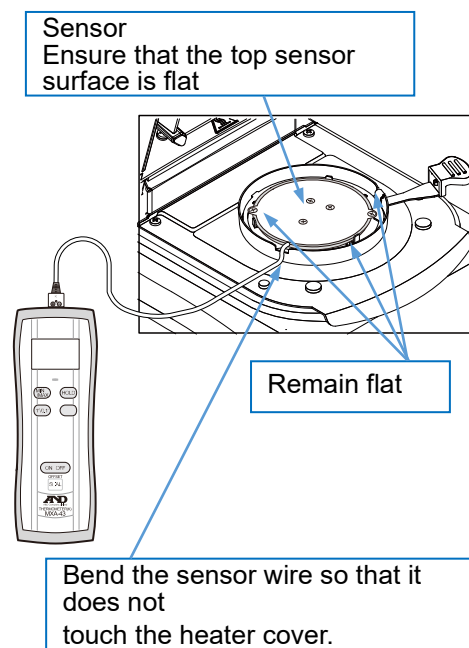
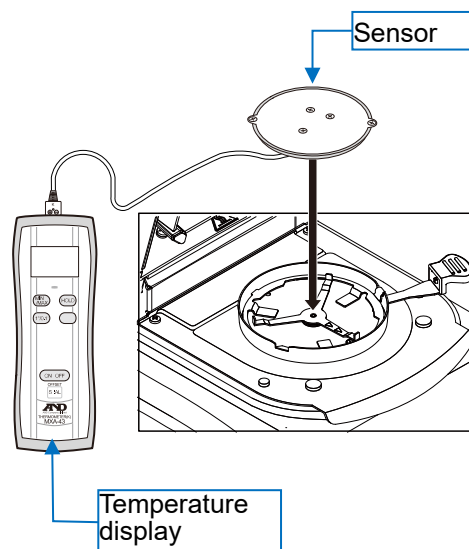

# 11. Internal Settings

Access method: [Home] > [Menu] > [Settings]

In [Settings], you can configure and change the operation and communication of the moisture analyzer. The setting values are retained even when the power cable is removed.

## 11.1. List of Items

Category	Setting (displayed item)	Set value (displayed value)	Description/purpose	
Clock adjustment	Date format	■ Year/Month/Day	Sets the date format to the year/month/day order.	
		Month/Day/Year		
		Day/Month/Year		
	Date/time display	Displays the current date and time.		
Date/time input	Inputs the date and time to set.			
	<input type="button" value="Set"/> button	Changes the date and time to those that are input.		
Common settings	Calculation data	■ Calculation with internal resolution	Perform calculations with priority given to the accuracy of the moisture content. The moisture content is calculated with more digits than the displayed mass.	
		Calculation with gram display resolution	The moisture content is calculated with the number of digits for the displayed mass.	
Display settings	Decimal separator	■ Point [.]	Selects the symbol to display and output for the decimal point.	
		Comma [,]		
	Backlight brightness	Level 1 }	Selects the brightness of the backlight.	
		Level 7		
Auto power off		■ Level 7	Default setting	
		■ Off	When no operations are performed for 10 minutes, the display automatically switches to the standby screen.	
		On (10 minutes)		
Language	Language	■ Japanese	Japanese	Selects the display language.
		English	English	
		Korean	Korean	
		Chinese	Chinese	
		Spanish	Spanish	
		German	German	
		French	French	
		Italian	Italian	
		Dutch	Dutch	

Category	Setting (displayed item)	Set value (displayed value)	Description/purpose	
Language	Language	Portuguese	Portuguese	
		Russian	Russian	

- indicates a default setting.

Category	Setting (displayed item)	Set value (displayed value)	Description/purpose
Data output	Data output mode  *1	▪ Key mode	Press the <input type="button" value="Data output"/> button to output data.
		Auto print mode	When measurement finishes, the data is automatically output.
		Stream mode	The data is continuously output during measurement.
	Output data selection	▪ Measurement results only	Output the measurement results only.
		Measurement results and temperature data	Output the measurement results and the temperature data.
	Data output interval	▪ No interval 1.6-second interval	Select the interval for data output.
GLP output	GLP output	▪ Off	The device information, measurement conditions, and signature space are not output.
		Output measurement results all at once	The device information, measurement conditions, and signature space are output together.
		Output measurement results separately	The measurement results, device information, measurement conditions, and signature space are output separately.
	Clock to use	▪ Internal clock External device clock	Select the clock to use for GLP output.
USB flash drive	Connection status	Displays the connection status of the USB flash drive.	
	Memory capacity	Displays the total capacity of the connected USB flash drive in MB.	
	Available memory	Displays the available capacity of the connected USB flash drive in MB.	
	<input type="button" value="Remove USB flash drive"/> button	Removes the connected USB flash drive.	
	<input type="button" value="Format USB flash drive"/> button	Formats the connected USB flash drive.	
USB communication	Connection status	Displays the connection status of the USB device.	
	USB device mode	Quick USB ▪ Virtual COM	Selects the connection method for using a USB cable.
Bluetooth  *2	Connection status	Displays the Bluetooth connection status.	
	Bluetooth	Off ▪ On	This setting enables or disables Bluetooth communication.
	Bluetooth mode	▪ Keyboard input (HID connection) Bidirectional communication	Selects the Bluetooth connection method.

Category	Setting (displayed item)	Set value (displayed value)	Description/purpose
Bluetooth	<input type="checkbox"/> Reset Bluetooth <input type="checkbox"/> device button		Resets the Bluetooth connection.

■ indicates a default setting.

\*1 Commands can be used in all modes.

\*2 The Bluetooth function is currently enabled for the US, Canada, Australia and Japan only.

Category	Setting (displayed item)	Set value (displayed value)	Description/purpose
Wired LAN	Connection status	Displays the connection status of the wired LAN.	
	IP address	0.0.0.0 }	Sets the IP address of the product.
		▪ 192.168.0.1	Default setting
	Subnet mask	0.0.0.0 }	Sets the subnet mask of the product.
		▪ 255.255.255.0	Default setting
	Default gateway	0.0.0.0 }	Sets the default gateway address.
▪ 0.0.0.0		Default setting	
For information on the value to set, ask your LAN administrator.			
Device identification number	Device identification number	Set a device identification number of your choice using single-byte alphanumeric characters or symbols.	
		▪ 0000000	Default setting
Backup settings	Backup of internal settings	<input type="button" value="Import"/> button	Imports moisture analyzer settings from the connected USB flash drive.
		<input type="button" value="Export"/> button	Exports moisture analyzer settings to the connected USB flash drive.
	Backup of measurement programs	<input type="button" value="Import"/> button	Imports moisture analyzer measurement programs from the connected USB flash drive.
		<input type="button" value="Export"/> button	Exports moisture analyzer measurement programs to the connected USB flash drive.
Factory settings	<input type="button" value="Initialize all"/> button	Restores the factory settings. Refer to " <a href="#">19.4. Factory Settings</a> ".	
	<input type="button" value="Initialize measurement programs only"/> button	Restores the factory settings for the measurement programs only. Refer to " <a href="#">19.4. Factory Settings</a> ".	
	<input type="button" value="Initialize internal settings only"/> button	Restores the factory settings for the settings only. Refer to " <a href="#">19.4. Factory Settings</a> ".	

▪ indicates a default setting.

## 11.2. Description of Clock Adjustment

Access method: [Home] > [Menu] > [Settings] > [Clock adjustment]

- The moisture analyzer contains a date/time function. This mode enables you to check and configure the date and time.
- If you set [GLP output] to [Output measurement results all at once] or [Output measurement results separately], GLP is output when outputting the moisture content measurement result and when performing weight sensor sensitivity adjustment and heater temperature adjustment.
- If you set [Clock to use] to [External device clock], the clock data of an external device is used.

### CAUTION

- Do not configure an invalid value (such as a date that does not exist).
- When the backup battery of the clock expires, "rtc PF" will be displayed.  
Battery replacement requires a repair at the place of purchase, but functions other than the clock will continue to operate even if the backup battery has expired. The clock function will also operate normally, as long as power is supplied to the moisture analyzer.
- Press the  button to configure the date and time.

## 11.3. Description of Common Settings

Access method: [Home] > [Menu] > [Settings] > [Common settings]

### Description of Calculation Data

- You can select whether to use the internal mass value (with more digits than the displayed mass) to improve the accuracy of calculating the moisture content, or use the number of digits for the displayed mass.
- If the internal mass value is used, the accuracy of the moisture content will be higher, but there may be a difference between the measurement result of the moisture analyzer and the moisture content separately calculated from the mass values output after drying and before drying.

## 11.4. Description of Display Settings

Access method: [Home] > [Menu] > [Settings] > [Display settings]

### Description of Auto Power Off

- With this function, the display switches to the standby screen if no operations are performed for a certain period of time (approx. 10 minutes).
- If you are logged in with the password function, you are automatically logged out before the display switches to the standby screen.

## CAUTION

- The display does not switch to the standby screen while heating or while the result is displayed.
- If you are logged in and no operations are performed for a certain period of time while the result is displayed, the display will switch to the standby screen when the product transitions to the mass display from the result display.

## 11.5. Description of Data Output

Access method: [Home] > [Menu] > [Settings] > [Data output]

---

### 11.5.1. Data output mode

---

#### Key mode

- You can press the Data output button to output the displayed mass value and moisture content once.

#### Auto print mode

- When moisture content measurement finishes, the measurement results are automatically output.
- You can also press the Data output button to output the displayed mass value and moisture content once.

## Stream mode

- The data is continuously output during measurement.
- You can also press the Data output button while the mass or result is displayed to output the displayed mass value and moisture content once.

### 11.5.2. Data Format

#### Standard A&D format

- This format is used when outputting data with USB communication (virtual COM), RS-232C, wired LAN, or Bluetooth (bidirectional communication). (Set [Output data selection] to [Measurement results only] and [GLP output] to [Off]<sup>\*1</sup>)
- Each item of data includes 15 characters. (Not including the terminator)
- The state of the data is indicated in a two character header.
- The data is signed and is zero-padded (leading spaces are filled with zeros).
- When the data is zero, it is deemed positive.
- Each item of data includes 3 characters.

USB communication (virtual COM),  
RS-232C, wired LAN,  
Bluetooth (bidirectional communication)

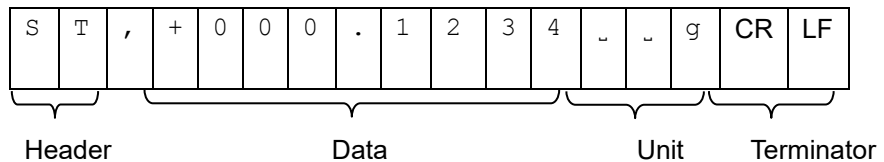

↓	S	T	When stable	CR	: Carriage return	ASCII code 0Dh
	U	S	When unstable	LF	: Line feed	ASCII code 0Ah
	O	L	When overloaded	_	: Space	ASCII code 20h

#### NU2 format

- This format is used when outputting data with USB communication (quick USB) or Bluetooth (keyboard input).  
(Set [Output data selection] to [Measurement results only] and [GLP output] to [Off]<sup>\*1</sup>)
- Only values are output.
- When the data is zero or a positive value, it is not signed.

USB communication (quick USB),  
Bluetooth (keyboard input)

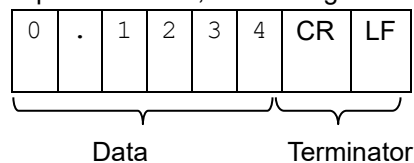

<sup>\*1</sup> Even when GLP output is enabled, data is output with this format while the mass is displayed and during measurement.

### 11.5.3. Example Output for Data Format

Sample mass value (data format output when performing measurement with the mass display or "g" for the unit)

20 °C 0.123 g

A&D	S	T	,		+	0	0	0	.	1	2	3	4	_	_	g	CR	LF
NU2	0	.	1		2	3	4	CR	LF									

When over (positive)

23 °C E g

A&D	0	L	,	+	9	9	9	9	9	9	9	E	+	1	9	CR	LF	
NU2	+	9	9	9	9	9	9	9	9	CR	LF							

When over (negative)

23 °C -E g

A&D	0	L	,	-	9	9	9	9	9	9	9	E	+	1	9	CR	LF	
NU2	-	9	9	9	9	9	9	9	9	CR	LF							

Moisture content (data format output during measurement or after measurement is finished)

\*The position of the decimal point in the data depends on the model and the minimum displayed.

(Set [Output data selection] to [Measurement results only] and [GLP output] to [Off])

105 °C 0:07:13 23.45<sup>MOIST</sup>/<sub>W</sub> %

A&D	S	T	,	+	0	0	0	2	3	.	4	5	_	_	%	CR	LF	
NU2	2	3	.	4	5	CR	LF											

When adding temperature data to the moisture content data

\*With Bluetooth (keyboard input), temperature data is not added.

(Set [Output data selection] to [Measurement results and temperature data] and [GLP output] to [Off])

105 °C 0:07:13 23.45<sup>MOIST</sup>/<sub>W</sub> %

A&D	1	0	5	,	S	T	,	+	0	0	0	2	3	.	4	5	_	_	%	CR	LF
NU2	1	0	5	TAB	2	3	.	4	5	CR	LF										

ASCII code 09h

TAB: Horizontal tab,

## 11.6. Backing Up Settings

- You can export moisture analyzer settings and program measurement conditions to the connected USB flash drive and then import those settings to another moisture analyzer to apply the same settings.
- A USB flash drive must be connected to execute the import or export process.
- When settings are exported, the file name is "Moisture\_Settings".
- When programs are exported, the file name is "Moisture\_Program".
- The exported file is saved to the root directory of the USB flash drive.
- When importing data, if the above file does not exist on the USB flash drive or the content of the file is invalid, an error message will be displayed.
- A "Moisture\_Program" file exported from a different model cannot be imported.

## 12. GLP Output

Access method: [Home] > [Menu] > [Settings] > [GLP output]

### 12.1. Main Uses

- If you set [GLP output] to [Output measurement results all at once] or [Output measurement results separately], data supporting GLP or GMP can be output from the moisture analyzer to a printer or computer.
- GLP refers to "Good Laboratory Practice".
- GMP refers to "Good Manufacturing Practice".
- The data output supporting GLP or GMP includes the moisture analyzer manufacturer name (A&D), model name, serial number, device identification number, date, time, and signature.
- With weight sensor sensitivity adjustment, the weight used and result are included in addition to the above.
- With heater temperature adjustment, the set temperature and result are included in addition to the above.
- The differences between each setting for GLP output are as follows.
- Measurement result output  
[Output measurement results all at once]: The device information, measurement conditions, and signature space are output together.  
[Output measurement results separately]: The device information, measurement conditions, and signature space are output separately.
- For information on checking/adjusting the date and time, refer to "[11.2. Description of Clock Adjustment](#)".
- When connecting the AD-8127 (multi printer) or AD-8129TH (thermal printer) to the moisture analyzer to print the GLP output, the clock function of the printer can be used to print the date and time (set [Settings] > [GLP output] > [Clock to use] to [External device clock]).
- Useful for the centralized management of date/time modification prevention using the password lock function of the AD-8127 or AD-8129TH.

### ADVICE

- When outputting data supporting GLP/GMP, set the print mode of the AD-8127 or AD-8129TH to the dump print mode (DUMP). If the external key print mode (EXT.KEY) was used to print the mass value and moisture content, you can press and hold (for approx. two seconds) the  button of the AD-8127 or AD-8129TH to switch between the external print mode and dump print mode.

### CAUTION

- The function for outputting external device clock data supports devices that can output a date and time when they receive <ESC>D and <ESC>T (such as AD-8127, AD-8129TH, and RsCom data communication software of WinCT, etc.)\*1
- \*1 <ESC> refers to an escape code (ASCII code 1Bh).
- The clock data saved to the measurement history is always the internal data. External device clock data cannot be used.

## 12.2. Example Measurement Result Output

### Example with All Data Output

- This method outputs the measurement results together with the device information, measurement conditions, measurement data, and signature space.
- Refer to "[11. Internal Settings](#)" to set [GLP output] to [Output measurement results all at once].



## Example Output (2)

When [GLP output] is set to [Output measurement results all at once] and [Clock to use] is set to [External device clock]

Printer output		Computer output (RsCom of WinCT)
A & D	← Manufacturer name	→ .....A_&_D<TERM>
MODEL MX-53AT	← Model name	→ MODEL.....MX-53AT<TERM>
S/N P1234567	← Serial number	→ S/N.....P1234567<TERM>
ID LAB-123	← ID	→ ID.....LAB-123<TERM>
PROGRAM No. 1	← Program number	→ PROGRAM...No...1<TERM>
PROGRAM ID	← Program ID	→ PROGRAM_ID<TERM>
SAMPLE		→ .....SAMPLE<TERM>
MODE STANDARD	← Measurement conditions*2	→ MODE.....STANDARD<TERM>
MEDIUM		→ .....MEDIUM<TERM>
DRYING STANDARD	← Heating pattern*2	→ DRYING...STANDARD<TERM>
105 C		→ .....105...C<TERM>
UNIT MOIST /W	← Measurement basis	→ UNIT.....MOIST_/W<TERM>
CP HI 20.0 %	← Comparator setting*4	→ CP...HI...20.0...%<TERM>
LO 19.0 %		→ ...LO...19.0...%<TERM>
OFFSET 1.23 %	← Correction value*3	→ OFFSET...1.23...%<TERM>
- - - - -		→ _ _ _ _ _<TERM>
INITIAL WEIGHT	← Wet sample mass	→ INITIAL_WEIGHT<TERM>
5.678 g		→ .....5.678...g<TERM>
FINAL WEIGHT	← Dried sample mass	→ FINAL_WEIGHT<TERM>
4.637 g		→ .....4.637...g<TERM>
RESULT MOIST /W	← Measurement result	→ RESULT...MOIST_/W<TERM>
19.57 %		→ .....19.57...%<TERM>
JUDGMENT OK	← Comparator result*4	→ JUDGMENT.....OK<TERM>
ANALYSIS TIME	← Measurement time*2	→ ANALYSIS_TIME<TERM>
6.7min		→ .....6.7min<TERM>
DATE 2024/08/01	← Measurement date/time	→ 2024-08-01<TERM>
TIME 12:34:56		→ 12:34:56<TERM>
USER NAME	← User name*5	→ USER_NAME<TERM>
Admin		→ Admin<TERM>
REMARKS	← Remarks space*2	→ REMARKS<TERM>
		→ <TERM>
		→ <TERM>
- - - - -		→ _ _ _ _ _<TERM>
SIGNATURE	← Signature space*2	→ SIGNATURE<TERM>
		→ <TERM>
		→ <TERM>
- - - - -		→ _ _ _ _ _<TERM>
		→ <TERM>

- \*1 The order and notation used for the year, month, and day depend on the version of WinCT and the configuration of the computer.
- \*2 Refer to "12.3. Description of Printed Information"
- \*3 Only printed when correction of measurement results is enabled and the setting value is not 0%.
- \*4 Only printed when the comparator is on
- \*5 Only printed when a user is logged in

- \_ : Space: ASCII 20h
- <TERM> : Terminator: CR LF
- CR : Carriage return: ASCII 0Dh
- LF : Line feed: ASCII 0Ah

## When Outputting Data Separately

- In this example, the device information, measurement conditions, and signature space are printed at a different time to the measurement data.
- This enables you to save paper when the measurement conditions are the same.
- Set [GLP output] to [Output measurement results separately].
- The method for printing the data depends on the internal settings of the moisture analyzer. (For details, refer to "[11.5.1. Data output mode](#)".)

Data output mode setting	Output method
Key mode	Press the <input type="button" value="Data output"/> button with the measurement result displayed.
Auto print mode	When measurement finishes, the measurement data is automatically printed.
Stream mode	Press the <input type="button" value="Data output"/> button with the measurement result displayed. (This mode is not suitable for only outputting the measurement data, because the moisture content is continuously output.)

# Example Output

When [GLP output] is set to [Output measurement results separately] and [Clock to use] is set to [Internal clock]

Printer output		Computer output (RsCom of Win-Ct)
A & D	←	A & D<TERM>
MODEL MX-53AT	←	MODEL_____MX-53AT<TERM>
S/N P1234567	←	S/N_____P1234567<TERM>
ID LAB-123	←	ID_____LAB-123<TERM>
PROGRAM No. 1	←	PROGRAM___No. ___1<TERM>
PROGRAM ID	←	PROGRAM_ID<TERM>
SAMPLE		_____SAMPLE<TERM>
MODE STANDARD	←	MODE_____STANDARD<TERM>
MEDIUM		_____MEDIUM<TERM>
DRYING STANDARD	←	DRYING___STANDARD<TERM>
105 C		_____105___C<TERM>
UNIT MOIST /W	←	UNIT_____MOIST_/W<TERM>
CP HI 20.0 %	←	CP___HI___20.0__%<TERM>
LO 19.0 %		_____LO___19.0__%<TERM>
OFFSET 1.23 %	←	OFFSET____1.23__%<TERM>
-----		-----<TERM>
INITIAL WEIGHT	←	INITIAL_WEIGHT<TERM>
5.678 g		_____5.678__g<TERM>
FINAL WEIGHT	←	FINAL_WEIGHT<TERM>
4.637 g		_____4.637__g<TERM>
RESULT MOIST /W	←	RESULT___MOIST_/W<TERM>
19.57 %		_____19.57__%<TERM>
JUDGMENT OK	←	JUDGMENT_____OK<TERM>
ANALYSIS TIME	←	ANALYSIS_TIME<TERM>
6.7min		_____6.7min<TERM>
DATE 2024/08/01	←	DATE___2024/08/01<TERM>
TIME 12:34:56	←	TIME_____12:34:56<TERM>
USER NAME	←	USER_NAME<TERM>
Admin		Admin<TERM>
REMARKS	←	REMARKS<TERM>
		<TERM>
		<TERM>
-----		-----<TERM>
INITIAL WEIGHT	←	INITIAL_WEIGHT<TERM>
5.791 g		_____5.791__g<TERM>
FINAL WEIGHT	←	FINAL_WEIGHT<TERM>
4.752 g		_____4.752__g<TERM>
RESULT MOIST /W	←	RESULT___MOIST_/W<TERM>
19.18 %		_____19.18__%<TERM>
JUDGMENT OK	←	JUDGMENT_____OK<TERM>
ANALYSIS TIME	←	ANALYSIS_TIME<TERM>
6.7min		_____6.7min<TERM>
DATE 2024/08/01	←	DATE___2024/08/01<TERM>
TIME 12:57:12	←	TIME_____12:57:12<TERM>
USER NAME	←	USER_NAME<TERM>
Admin		Admin<TERM>
REMARKS	←	REMARKS<TERM>
		<TERM>
		<TERM>
-----		-----<TERM>
SIGNATURE	←	SIGNATURE<TERM>
		<TERM>
		<TERM>
-----		-----<TERM>
		<TERM>
		<TERM>

\*1 Refer to "12.3. Description of Printed Information"  
 \*2 Only printed when correction of measurement results is enabled and the setting value is not 0%  
 \*3 Only printed when the comparator is on  
 \*4 Only printed when a user is logged in





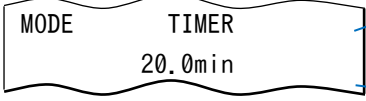
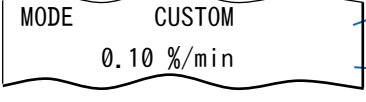

  : Space: ASCII 20h  
 <TERM> : Terminator: CR LF  
 CR : Carriage return: ASCII 0Dh  
 LF : Line feed: ASCII 0Ah

## 12.3. Description of Printed Information

### Measurement mode and measurement conditions

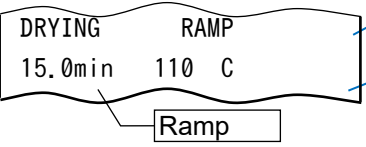
Measurement mode	Printed part and description
Standard mode	 <p>Standard</p> <p>Measurement accuracy setting HIGH, MEDIUM, or LOW is printed.</p>
Timer mode	 <p>Timer mode</p> <p>Measurement time</p>
Custom mode	 <p>Custom mode</p> <p>Measurement</p>

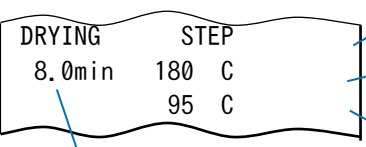
### Heating pattern

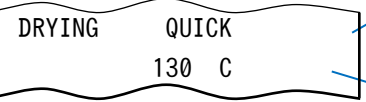
Heating pattern	Printed part and description
Standard 	 <p>Standard heating</p> <p>Sample pan temperature</p>
Ramp 	 <p>Ramp heating</p> <p>Target sample pan temperature</p> <p>Ramp</p>
Step 	 <p>Step heating</p> <p>Step 1 sample pan</p> <p>Step 2 sample pan</p> <p>Step 1 drying time</p>
Quick 	 <p>Quick heating</p> <p>Sample pan temperature</p>

## Measurement basis

Measurement basis	Printed part	Calculation formula of displayed value	Display
Moisture content (wet basis) <sup>*1</sup>		$\frac{W - D}{W} \times 100$	% MOIST /W
Moisture content (Atró) (dry basis, Atró) <sup>*2</sup>		$\frac{W - D}{D} \times 100$	% MOIST /D
Solid content		$\frac{D}{W} \times 100$	% RATIO D/W
Ratio <sup>*2</sup>		$\frac{W}{D} \times 100$	% RATIO W/D
Grams		— <sup>*3</sup>	g

W: Wet sample mass

D: Dried sample mass

\*1 Default setting

\*2 If the dried sample mass decreases and the measured value exceeds 999%, operation automatically stops because the measurement results cannot be calculated correctly.

\*3 The moisture content result is derived from the moisture content (wet basis).

## Comparator

- Only output when the comparator is on.

Item	Printed part and description
Set value	

Judgment formula	Judgment result	Printed part
Upper limit < moisture content	HI	
Lower limit ≤ moisture content ≤ upper limit	OK	
Moisture content < lower limit	LO	

## Correction value

- Only output when correction of measurement results is enabled.

--

## Measurement date/time

- The measurement date/time outputs the date/time of the clock in the moisture analyzer.
- The date order (YYYYMMDD, MMDDYYYY, or DDMMYYYY) follows the setting in [Settings] > [Clock adjustment] > [Date format].

DATE	2024/08/01
TIME	13:24:57

## Remarks space

- Enables you to enter a comment such as the name of the measured sample.

REMARKS
---------

## Signature space

- Enables you to write your signature.

SIGNATURE
-----------

## 12.4. Weight Sensor Output for Sensitivity Adjustment

- The GLP output when performing weight sensor sensitivity adjustment is indicated below.

### Example Output

When [Clock to use] is set to [Internal clock]

Printer output		Computer output (RsCom of WinCT)
A & D	← Manufacturer name →	_____A_&_D<TERM>
MODEL MX-53AT	← Model name →	MODEL_____MX-53AT<TERM>
S/N P1234567	← Serial number →	S/N_____P1234567<TERM>
ID LAB-123	← ID →	ID_____LAB-123<TERM>
DATE 2024/08/01	← Date →	DATE__2024/08/01<TERM>
TIME 12:34:56	← Time →	TIME_____12:34:56<TERM>
ADJUSTED	← Sensitivity adjustment (weight sensor) →	ADJUSTED<TERM>
WEIGHT		_____WEIGHT<TERM>
CAL. WEIGHT	← Weight value →	CAL.WEIGHT<TERM>
20.000 g		_____20.000__g<TERM>
USER NAME	← User name*1 →	USER_NAME<TERM>
Admin		Admin<TERM>
REMARKS	← Remarks space →	REMARKS<TERM>
		<TERM>
		<TERM>
-----		_____<TERM>
SIGNATURE	← Signature space →	SIGNATURE<TERM>
		<TERM>
		<TERM>
-----		_____<TERM>
		<TERM>
		<TERM>

\*1 Only printed when a user is logged in

\_ : Space: ASCII 20h  
 <TERM> : Terminator: C<sub>R</sub> L<sub>F</sub>  
 C<sub>R</sub> : Carriage return: ASCII 0Dh  
 L<sub>F</sub> : Line feed: ASCII 0Ah

## 12.5. Output for Heater Temperature Adjustment

- The GLP output when performing heater temperature adjustment is indicated below.

### Example Output

When [Clock to use] is set to [Internal clock]

Printer output		Computer output (RsCom of WinCT)
A & D	←	Manufacturer name →
MODEL MX-53AT	←	Model name →
S/N P1234567	←	Serial number →
ID LAB-123	←	ID →
DATE 2024/08/01	←	Date →
TIME 12:34:56	←	Time →
ADJUSTED	←	Sensitivity adjustment (heater temperature) →
TEMPERATURE		TEMPERATURE →
TARGET ACTUAL		TARGET ACTUAL →
100 C 97 C	←	Target temperature 100°C, actual temperature →
160 C 162 C	←	Target temperature 160°C, actual temperature →
USER NAME	←	User name*1 →
Admin		
REMARKS	←	Remarks space →
-----		
SIGNATURE	←	Signature space →
-----		

\*1 Only printed when a user is logged in

\_ : Space: ASCII 20h  
 <TERM> : Terminator: C<sub>R</sub> L<sub>F</sub>  
 C<sub>R</sub> : Carriage return: ASCII 0Dh  
 L<sub>F</sub> : Line feed: ASCII 0Ah

## 12.6. Output for Daily Check

- The GLP output when performing a daily check is indicated below.

### Example Output

When [Clock to use] is set to [Internal clock]

Printer output		Computer output (RsCom of WinCT)
--DAILY CHECK--		--DAILY_CHECK--<TERM>
A & D	← Manufacturer name →	A_&_D<TERM>
MODEL MX-53AT	← Model name →	MODEL_____MX-53AT<TERM>
S/N P1234567	← Serial number →	S/N_____P1234567<TERM>
ID LAB-123	← ID →	ID_____LAB-123<TERM>
DATE 2024/08/01	← Date →	DATE__2024/08/01<TERM>
TIME 12:34:56	← Time →	TIME_____12:34:56<TERM>
WARM UP 001h	← Warm-up time →	WARM_UP_____001h<TERM>
		<TERM>
ENVIRONMENT	← Surrounding environment →	ENVIRONMENT<TERM>
OK		OK<TERM>
EXT. CONDITION	← Exterior and heater section →	EXT.CONDITION<TERM>
OK		OK<TERM>
SAMPLE PAN	← Sample pan →	SAMPLE PAN<TERM>
OK		OK<TERM>
WEIGHT SENSOR	← Weight sensor →	WEIGHT SENSOR<TERM>
OK		OK<TERM>
TEMP SENSOR	← Temperature sensor →	TEMP SENSOR<TERM>
OK		OK<TERM>
USER NAME	← User name*1 →	USER_NAME<TERM>
Admin		Admin<TERM>
REMARKS	← Remarks space →	REMARKS<TERM>
		<TERM>
- - - - -		- - - - -<TERM>
SIGNATURE	← Signature space →	SIGNATURE<TERM>
		<TERM>
		<TERM>
- - - - -		- - - - -<TERM>
		<TERM>
		<TERM>

\*1 Only printed when a user is logged in

\_ : Space: ASCII 20h  
 <TERM> : Terminator: C<sub>R</sub> L<sub>F</sub>  
 C<sub>R</sub> : Carriage return: ASCII 0Dh  
 L<sub>F</sub> : Line feed: ASCII 0Ah

## 12.7. Output for Test Sample Measurement

- The GLP output when performing test sample measurement is indicated below.

### Example Output

When [Clock to use] is set to [Internal clock]

Printer output		Computer output (RsCom of WinCT)
A & D	←	Manufacturer name →
MODEL MX-53AT	←	Model name →
S/N P1234567	←	Serial number →
ID LAB-123	←	ID →
---TEST MODE---		---TEST__MODE---<TERM>
TEST SAMPLE	←	Test sample name →
C4H4Na2O6 2H2O		__C4H4Na2O6_2H2O<TERM>
CP HI 16.0 %	←	Comparator setting →
LO 15.4 %		____LO____15.4__%<TERM>
-----		____-<TERM>
INITIAL WEIGHT	←	Wet sample mass →
5.039 g		INITIAL_WEIGHT<TERM>
FINAL WEIGHT	←	Dried sample mass →
4.242 g		FINAL_WEIGHT<TERM>
RESULT MOIST /W	←	Measurement result →
15.80 %		RESULT__MOIST_/W<TERM>
JUDGEMENT OK	←	Test result →
ANALYSIS TIME	←	Measurement time →
10.3min		____10.3min<TERM>
DATE 2024/08/01	←	Date →
TIME 12:34:56	←	Time →
USER NAME	←	User name*1 →
Admin		USER_NAME<TERM>
REMARKS	←	Remarks space →
		REMARKS<TERM>
		<TERM>
		<TERM>
-----		____-<TERM>
SIGNATURE	←	Signature space →
		SIGNATURE<TERM>
		<TERM>
		<TERM>
-----		____-<TERM>
		<TERM>
		<TERM>

\*1 Only printed when a user is logged in

\_ : Space: ASCII 0h  
 <TERM> : Terminator: CR LF  
 CR : Carriage return: ASCII 0Dh  
 LF : Line feed: ASCII 0Ah

## 12.8. Output for Automatic Drying Temperature Judgment (RsTemp)

- The GLP output for when performing automatic drying temperature judgment (RsTemp) is indicated below.

### Example Output

When [Clock to use] is set to [Internal clock]

Printer output		Computer output (RsCom of WinCT)
A & D	←	A & D<TERM>
MODEL MX-53AT	←	MODEL_____MX-53AT<TERM>
S/N P1234567	←	S/N_____P1234567<TERM>
ID LAB-123	←	ID_____LAB-123<TERM>
DATE 2024/08/01	←	DATE___2024/08/01<TERM>
TIME 12:34:56	←	TIME_____12:34:56<TERM>
START TEMP 100C	←	START_TEMP__100C<TERM>
STEP TEMP 20C	←	STEP_TEMP____20C<TERM>
STEP TIME 5min	←	STEP_TIME____5min<TERM>
-----<TERM>		-----<TERM>
TEMP1 100C	←	TEMP1_____100C<TERM>
MOIST 3.26 %	←	MOIST_____3.26__%<TERM>
RATE 0.41%/min	←	RATE____0.41%/min<TERM>
JUDGEMENT E	←	JUDGEMENT_____E<TERM>
		<TERM>
TEMP2 120C	←	TEMP2_____120C<TERM>
MOIST 11.05 %	←	MOIST_____11.05__%<TERM>
RATE 1.66%/min	←	RATE____1.66%/min<TERM>
JUDGEMENT F	←	JUDGEMENT_____F<TERM>
		<TERM>
TEMP3 140C	←	TEMP3_____140C<TERM>
MOIST 15.68 %	←	MOIST_____15.68__%<TERM>
RATE 0.10%/min	←	RATE____0.10%/min<TERM>
JUDGEMENT D	←	JUDGEMENT_____D<TERM>
		<TERM>
TEMP4 160C	←	TEMP4_____160C<TERM>
MOIST 15.72 %	←	MOIST_____15.72__%<TERM>
RATE 0.00%/min	←	RATE____0.00%/min<TERM>
JUDGEMENT B	←	JUDGEMENT_____B<TERM>
		<TERM>
TEMP5 180C	←	TEMP5_____180C<TERM>
MOIST 15.72 %	←	MOIST_____15.72__%<TERM>
RATE 0.00%/min	←	RATE____0.00%/min<TERM>
JUDGEMENT A	←	JUDGEMENT_____A<TERM>
		<TERM>
TEMP6 200C	←	TEMP6_____200C<TERM>
MOIST 15.72 %	←	MOIST_____15.72__%<TERM>
RATE -0.02%/min	←	RATE___-0.02%/min<TERM>
JUDGEMENT C	←	JUDGEMENT_____C<TERM>
		<TERM>
USER NAME	←	USER_NAME<TERM>
Admin		Admin<TERM>
REMARKS	←	REMARKS<TERM>
		<TERM>
-----<TERM>		-----<TERM>
SIGNATURE	←	SIGNATURE<TERM>
		<TERM>
-----<TERM>		-----<TERM>
		<TERM>
		<TERM>

\*1 Only printed when a user is logged in

\_ : Space: ASCII 20h  
 <TERM> : Terminator: C<sub>R</sub> L<sub>F</sub>  
 C<sub>R</sub> : Carriage return: ASCII 0Dh  
 L<sub>F</sub> : Line feed: ASCII 0Ah

## 12.9. Output for Plastic Drying Temperature Judgment (PITemp)

- The GLP output for when performing plastic drying temperature judgment (PITemp) is indicated below.

### Example Output

When [Clock to use] is set to [Internal clock]

Printer output		Computer output (RsCom of WinCT)
A & D	←	Manufacturer name →
MODEL MS-74AT	←	Model name →
S/N P1234567	←	Serial number →
ID LAB-123	←	ID →
DATE 2024/08/01	←	Date →
TIME 12:34:56	←	Time →
START TEMP 100C	←	Starting temperature →
STEP TEMP 20C	←	Step temperature →
STEP TIME 5min	←	Step time →
-----		-----
TEMP1 100C	←	Set temperature →
MOIST 0.745 %	←	Measurement result →
RATE 0.807%/min	←	Drying rate →
JUDGEMENT OK	←	Judgment result →
		<TERM>
TEMP2 120C	←	Set temperature →
MOIST 1.742 %	←	Measurement result →
RATE 0.499%/min	←	Drying rate →
JUDGEMENT OK	←	Judgment result →
		<TERM>
TEMP3 140C	←	Set temperature →
MOIST 1.994 %	←	Measurement result →
RATE 0.250%/min	←	Drying rate →
JUDGEMENT OK	←	Judgment result →
		<TERM>
TEMP4 160C	←	Set temperature →
MOIST 2.254 %	←	Measurement result →
RATE 0.203%/min	←	Drying rate →
JUDGEMENT NOT OK	←	Judgment result →
		<TERM>
TEMP5 180C	←	Set temperature →
MOIST ----- %	←	Measurement result →
RATE -----%/min	←	Drying rate →
JUDGEMENT --	←	Judgment result →
		<TERM>
TEMP6 200C	←	Set temperature →
MOIST ----- %	←	Measurement result →
RATE -----%/min	←	Drying rate →
JUDGEMENT --	←	Judgment result →
		<TERM>
USER NAME	←	User name*1 →
Admin		Admin<TERM>
REMARKS	←	Remarks space →
		REMARKS<TERM>
		<TERM>
-----		-----<TERM>
SIGNATURE	←	Signature space →
		SIGNATURE<TERM>
		<TERM>
-----		-----<TERM>
		<TERM>

\*1 Only printed when a user is logged in

- \_ : Space: ASCII 20h
- <TERM> : Terminator: C<sub>R</sub> L<sub>F</sub>
- C<sub>R</sub> : Carriage return: ASCII 0Dh
- L<sub>F</sub> : Line feed: ASCII 0Ah

## 12.10. Output for Determination of Drying Time

- The GLP output when determining the drying time is indicated below.

### Example Output

When [Clock to use] is set to [Internal clock]

Printer output		Computer output (RsCom of WinCT)
A & D	← Manufacturer name →	.....A_&_D<TERM>
MODEL MS-74AT	← Model name →	MODEL.....MS-74AT<TERM>
S/N P1234567	← Serial number →	S/N.....P1234567<TERM>
ID LAB-123	← ID →	ID.....LAB-123<TERM>
DATE 2025/04/01	← Date →	DATE__2025/04/01<TERM>
TIME 12:34:56	← Time →	TIME.....12:34:56<TERM>
SET TEMP 120C	← Set temperature →	SET_TEMP.....120C<TERM>
MAX TIME 30min	← Maximum measurement time →	MAX_TIME.....30min<TERM>
-----		.....<TERM>
HI 0.010%/min		HI.....0.010%/min<TERM>
1.229 %	← Measurement result →	.....1.229_<TERM>
JUDGEMENT 20min	← Judgment result →	JUDGEMENT__20min<TERM>
		<TERM>
MID. 0.020%/min		MID._.0.020%/min<TERM>
1.265 %	← Measurement result →	.....1.265_<TERM>
JUDGEMENT 16min	← Judgment result →	JUDGEMENT__16min<TERM>
		<TERM>
LO 0.100%/min		LO.....0.100%/min<TERM>
0.682 %	← Measurement result →	.....0.682_<TERM>
JUDGEMENT 5min	← Judgment result →	JUDGEMENT__5min<TERM>
USER NAME	← User name*1 →	USER_NAME<TERM>
Admin		Admin<TERM>
REMARKS	← Remarks space →	REMARKS<TERM>
		<TERM>
		<TERM>
-----		.....<TERM>
SIGNATURE	← Signature space →	SIGNATURE<TERM>
		<TERM>
		<TERM>
-----		.....<TERM>
		<TERM>
		<TERM>

\*1 Only printed when a user is logged in

\_ : Space: ASCII 20h  
 <TERM> : Terminator: C<sub>R</sub> L<sub>F</sub>  
 C<sub>R</sub> : Carriage return: ASCII 0Dh  
 L<sub>F</sub> : Line feed: ASCII 0Ah

## 12.11. Output for Thermal Analysis Mode

- The GLP output when using the thermal analysis mode is indicated below.

### Example Output

When [Clock to use] is set to [Internal clock]

Printer output		Computer output (RsCom of WinCT)
A & D	← Manufacturer name →	.....A_&_D<TERM>
MODEL MX-53AT	← Model name →	MODEL_...MX-53AT<TERM>
S/N P1234567	← Serial number →	S/N_...P1234567<TERM>
ID LAB-123	← ID →	ID_...LAB-123<TERM>
DATE 2024/08/01	← Date →	DATE_..2024/08/01<TERM>
TIME 12:34:56	← Time →	TIME_...12:34:56<TERM>
THERMAL ANALYSIS		THERMAL_ANALYSIS<TERM>
1 130C 5min	← Temperature and time of each step →	1_...130C_...5min<TERM>
2 130C 5min	← Temperature and time of each step →	2_...130C_...5min<TERM>
3 130C 5min	← Temperature and time of each step →	3_...130C_...5min<TERM>
4 130C 5min	← Temperature and time of each step →	4_...130C_...5min<TERM>
5 130C 5min	← Temperature and time of each step →	5_...130C_...5min<TERM>
-----		.....<TERM>
INITIAL WEIGHT	← Wet sample mass →	INITIAL_WEIGHT<TERM>
5.678 g		.....5.678_g<TERM>
FINAL WEIGHT	← Dried sample mass →	FINAL_WEIGHT<TERM>
4.637 g		.....4.637_g<TERM>
RESULT MOIST /W	← Measurement result →	RESULT_..MOIST_/W<TERM>
19.57 %		.....19.57_%%<TERM>
USER NAME	← User name*1 →	USER_NAME<TERM>
Admin		Admin<TERM>
REMARKS	← Remarks space →	REMARKS<TERM>
		<TERM>
		<TERM>
-----		.....<TERM>
SIGNATURE	← Signature space →	SIGNATURE<TERM>
		<TERM>
		<TERM>
-----		.....<TERM>
		<TERM>
		<TERM>

\*1 Only printed when a user is logged in

\_ : Space: ASCII 20h  
 <TERM> : Terminator: C<sub>R</sub> L<sub>F</sub>  
 C<sub>R</sub> : Carriage return: ASCII 0Dh  
 L<sub>F</sub> : Line feed: ASCII 0Ah

## 13. PDF Report

You can export the measurement results to a USB flash drive as a PDF file.

The applications that can export PDF reports are indicated below.

Category	Application	PDF file name <sup>*1</sup>
Measurement	Programmed measurement Simple measurement	MEASUREMENT_*****.pdf
Check/Adjustment	Test sample measurement	TESTSAMPLE_*****.pdf
Measurement Guide	Automatic Drying Temperature Judgment (RsTemp)	RS-TEMP_*****.pdf

\*1 \*\*\*\*\* refers to the date and time. Example: 20250102123456 for 12:34:56 on January 2, 2025

### Operation Method

- Connect a USB flash drive to the USB Type-A connector on the side of the main unit.
- Perform measurement in the above application and display the results.
- Press the  button on the result screen to zoom in the graph.
- You can press the  button to output a PDF report to a USB flash drive.

### CAUTION

- The  button is not available unless a USB flash drive is connected.

# 13.1. Programmed Measurement Report

- This PDF report is for programmed measurement.

## Example Output

### Measurement results

Start time : 2025/05/14 11:47                      End time : 2025/05/14 11:54  
 Model name : MS-74AT    Serial number : 00000000    ID number : 00000000

Program name : SAMPLE \_\_\_\_\_

Program No : 1                      Program ID : SAMPLE

### Measurement conditions

Measurement mode : Standard mode	
Measurement accuracy : MEDIUM	Drying temp : 105°C
Heating pattern : Standard	
Unit : Moisture content (wet basis)	
Comparator : Off	
Preheating : Off	Automatic measurement start : On
Fiberglass sheet : None	
Pretreatment : None	
Correction : Off	

### Results

Moisture percentage : 2.583 %	Measurement : Completed
Measurement Time : 0:07:05	Comparator : Off
Wet sample mass : 5.148 g	Dried sample mass : 5.015 g

**105°C    0:07:05    2.583%    0.014%/min**

Remark	Measurer name
	Approver name

## 13.2. Test Sample Measurement Report

- This PDF report is for test sample measurement.

### Example Output

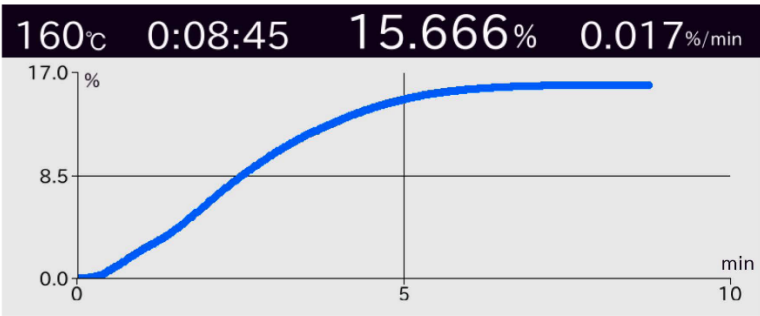
<h3>Test sample measurement results</h3>																										
Start time : 2025/05/14 12:03	End time : 2025/05/14 12:12																									
Model name : MS-74AT	Serial number : 00000000	ID number : 0000000																								
Test Sample : Sodium tartrate dihydrate																										
Target moisture content (passing range) : 15.66%(15.4 - 16.0%)																										
<u>Measurement conditions</u>																										
Measurement mode : Standard mode																										
Heating pattern : Standard																										
Measurement accuracy : MEDIUM																										
Sample mass : 5.000 g	Temperature : 160 C	Preheating : Off																								
Unit : Moisture content (wet basis)																										
Preset termination value : 0.02 %/min																										
<u>Results</u>																										
Judgement : OK																										
Moisture percentage : 15.666 %	Measurement time : 0:08:45																									
Wet sample mass : 5.000 g	Dried sample mass : 4.217g																									
 <table border="1" data-bbox="414 1265 1177 1579"><tr><td>160°C</td><td>0:08:45</td><td>15.666%</td><td>0.017%/min</td></tr><tr><td>17.0 %</td><td></td><td></td><td></td></tr><tr><td>8.5</td><td></td><td></td><td></td></tr><tr><td>0.0</td><td></td><td></td><td></td></tr><tr><td>0</td><td>5</td><td></td><td>10</td></tr><tr><td></td><td></td><td></td><td>min</td></tr></table>			160°C	0:08:45	15.666%	0.017%/min	17.0 %				8.5				0.0				0	5		10				min
160°C	0:08:45	15.666%	0.017%/min																							
17.0 %																										
8.5																										
0.0																										
0	5		10																							
			min																							
Remark	Measurer name																									
	Approver name																									

# 13.3. Automatic Drying Temperature Judgment (RsTemp) Report

- This PDF report is for automatic drying temperature judgment (RsTemp).

## Example Output

### RS-TEMP

Start time : 2025/05/14 13:15                      End time : 2025/05/14 13:45

Model data

Model name : MS-74AT    ID number : 00000000  
 Serial number : 00000000

Measurement conditions

Set temp : 100 C  
 Step temperature : 20 C  
 Step time : 5 min

Results

Temp[C]	100	120	140	160	180	200
Moisture percentage[%]	5.398	14.268	15.949	15.988	16.016	16.036
Amount of change[%/min]	0.865	1.063	0.006	0.003	0.004	0.004
Judgement	E	F	D	A	B	B

Remark	Measurer name
	Approver name

## 14. Measurement History

Access method: [Home] > [Menu] > [Measurement history]

The measurement history automatically records the measurement results when measurement is complete. Up to 3,000 sets of data can be recorded. If this number is exceeded, the oldest data is deleted.

The recorded measurement results can be output to the multi-printer (AD-8127) or thermal printer (AD-8129TH) or imported to a computer using the communication software (WinCT).

The following applications are recorded to the measurement history.

- Simple measurement
- Programmed measurement
- Preset programs
- Test sample measurement (the access method differs, as described in "[10.3.2. Test Sample Measurement History](#)").

You can press the trend button to display a trend graph of the past 10 measurement results.

### CAUTION

- Data can be deleted with the  button, but the trend graph will not be deleted.

### 14.1. Information Recorded in Measurement History

- With measurement history, the following information is recorded.

Information recorded in measurement history
Program name for measurement
Program ID for measurement
Measurement conditions for measurement
Date
Time
Measurement result
Drying rate when measurement ends
Measurement time
Wet sample mass
Dried sample mass

## 14.2. Output of Recorded Results

- With measurement history output, the data is output in a format like the following.

### Example Output

Printer output

A & D	←	Manufacturer name
MODEL MX-53AT	←	Model name
S/N P1234567	←	Serial number
ID LAB-123	←	ID
PROGRAM No. 1	←	Program number
PROGRAM ID	←	Program ID
SAMPLE		
MODE STANDARD	←	Measurement conditions <sup>*1</sup>
MEDIUM		
DRYING STANDARD	←	Heating pattern <sup>*1</sup>
105 C		
UNIT MOIST /W	←	Measurement basis
CP HI 20.0 %	←	Comparator setting <sup>*3</sup>
LO 19.0 %		
OFFSET 1.23 %	←	Correction value <sup>*2</sup>
-----		
INITIAL WEIGHT	←	Wet sample mass
5.678 g		
FINAL WEIGHT	←	Dried sample mass
4.637 g		
RESULT MOIST /W	←	Measurement result
19.57 %		
JUDGMENT OK	←	Comparator result <sup>*3</sup>
ANALYSIS TIME	←	Measurement time <sup>*1</sup>
6.7min		
DATE 2024/08/01	←	Measurement date/time
TIME 12:34:56		
REMARKS		
-----		
SIGNATURE		
-----		

<sup>\*1</sup> Refer to "12.3. Description of Printed Information"

<sup>\*2</sup> Only printed when correction of measurement results is enabled and the setting value is not 0%

<sup>\*3</sup> Only printed when the comparator is on

## CAUTION

- In the default internal settings, [Data output interval] is set to [No interval]. When it is necessary to have an interval because the output destination is a printer, etc., refer to "11. Internal Settings" to change it to [1.6-second interval].

## 15. Password Function

The password function enables the use of the moisture analyzer and its functions to be restricted. This is useful for preventing modifications to the date and time settings and changes to the internal settings by non-administrator users.

To log in, enter the user name and password in [Home] > [Login], then press the  button.

To log out, press the  button or press the  key to turn the display off.

### User level

- Functions can be restricted by user level.
- By default, all functions are allowed for all user levels.
- There are four user levels: [Administrator], [Lab manager], [Supervisor], and [Operator].
- The [Lab manager] and [Supervisor] user levels can be selected by users.
- Users that are not logged in are at the [Operator] user level (for users that do not use the password function).

### Admin (administrator)

- User management (registering, editing, and deleting users) and user permissions (for limiting functions) are only available for Admin. The  and  buttons are only displayed on the login screen when you are logged in as Admin.
- Admin is registered by default and cannot be deleted or changed to another user level.
- The default Admin password is "0000". When using the password function, make sure to change the Admin password. If the Admin password is forgotten, you will not be able to perform user management or change user permissions. To cancel the password, contact your place of purchase.

### User management settings

- You can register, edit, and delete users.
- The items displayed in the user management settings are as follows.

Displayed item	Description
User list	Displays the registered users. By default, only Admin is registered, but a maximum of 100 users can be registered.
<input type="button" value="Add"/> button	Registers a user. To register a new user, configure the user name, password, and user level, then press the <input type="button" value="Register this user"/> button. <sup>*1</sup>
<input type="button" value="Delete"/> button	Deletes a user. To delete a user, select the user in the user list, then press the <input type="button" value="Delete"/> button. When the dialog is displayed, press <input type="button" value="YES"/> . <sup>*2</sup>
<input type="button" value="Edit"/> button	Edits the user. To edit a user, select the user in the user list, then press the <input type="button" value="Edit"/> button. Change the password and user level, then press the <input type="button" value="Apply changes"/> button. <sup>*3</sup>
User name	Displayed when registering a user. You can input up to 20 characters for a user name. <sup>*4</sup>
Password	Displayed when registering or changing a user. The password is fixed to four characters. <sup>*4</sup>
User level	Displayed when registering or changing a user. Select [Supervisor] or [Lab manager].

<sup>\*1</sup> A user name with the same name as an existing user name cannot be registered.

<sup>\*2</sup> Admin cannot be deleted.

<sup>\*3</sup> The user level of Admin cannot be changed. The user name cannot be changed.

<sup>\*4</sup> The available characters are as follows.

Single-byte letters, single-byte numbers, and single-byte symbols

## User permission settings

- The functions and usage of the moisture analyzer can be restricted by user level.
- When a function is restricted, the corresponding buttons and setting changes are disabled and grayed out.
- The functions that can be restricted by user level are indicated below.

Item	Description	Function disabled when not allowed
Measurement	All moisture content measurement	• All buttons for starting measurement
Program editing	Changing measurement conditions	<ul style="list-style-type: none"> <li>• Changing measurement conditions for simple measurement and programmed measurement <sup>*2</sup></li> <li>• Changing measurement conditions for the measurement guide and plastic measurement guide</li> <li>• Changing the weighing settings</li> <li>• Changing measurement conditions for the thermal analysis mode</li> <li>• Deleting measurement history</li> </ul>
Sensitivity adjustment	Weight sensor sensitivity adjustment and heater temperature adjustment	<ul style="list-style-type: none"> <li>• Executing weight sensor sensitivity adjustment</li> <li>• Executing heater temperature adjustment</li> </ul>
Change to settings	All setting items	• Changing and initializing settings other than measurement conditions
Changing the date and time	Main unit clock adjustment	• Clock adjustment <sup>*1</sup>

<sup>\*1</sup> When changes to settings are not allowed, changes to the date and time are also restricted.

<sup>\*2</sup> Changes from the Measurement Guide and the Plastic Measurement Guide are also restricted.

## 16. Interface Specifications

### 16.1. USB

Connector	Type-C (female)
Standard	USB 2.0
Device class	HID (human interface device): Quick USB CDC (communication device class): Virtual COM

Connector	Type-A (USB flash drive only)
Standard	USB 2.0
Device class	MSC (mass storage class)

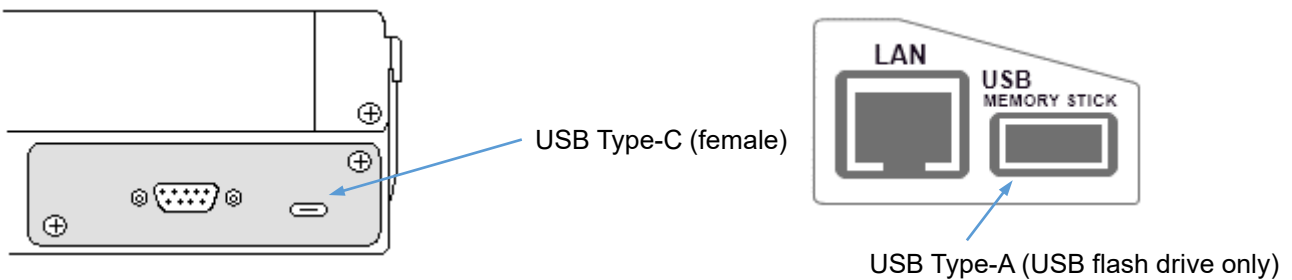

- To use USB, it must be selected in [Settings] > [USB flash drive] and [USB communication].

#### 16.1.1. USB Type-C (USB device: quick USB, virtual COM)

- Communication can be performed with a computer by connecting the included USB cable to the USB Type-C connector.
- Two communication modes are available: The virtual COM mode that enables bidirectional communication and the quick USB mode that is specialized for unidirectional communication.
- For details on the modes and the method for connecting to a computer, refer to "[17.3.1. Virtual COM Mode](#)" and "[17.3.2. Quick USB Mode](#)".

### CAUTION

- Power cannot be supplied from a USB AC adapter or mobile battery. Do not connect a USB AC adapter or mobile battery, as doing so may cause product failure.
- USB Type-C USB flash drives cannot be used.
- Power cannot be supplied to external devices from the moisture analyzer.

---

## 16.1.2. USB Type-A (USB host: USB flash drive)

---

- You can connect a USB flash drive to the USB Type-A connector. By saving measurement data, etc. to a USB flash drive, data can be easily imported to a computer running Windows or Mac OS. (A driver is also not required.)
- You can save measurement results and other data to the USB flash drive in the PDF format.

### CAUTION

- Do not connect a device other than a USB flash drive to the USB Type-A connector.
- Before removing a USB flash drive from the moisture analyzer, press the Remove USB flash drive button. Data may not be written unless operations are performed correctly.
- To prevent any potential data loss, only use the USB flash drive with this product, and avoid using it in conjunction with other devices.
- If other data is saved, the data may become damaged. A&D will not be held responsible for any data loss. Before using a USB flash drive with this product, make sure to format it on a computer.
- A USB flash drive with security functions (such as anti-virus software) cannot be used.
- A USB flash drive formatted with NTFS or exFAT cannot be used. Use a USB flash drive formatted with FAT (FAT 16) or FAT 32.
- Even if the above requirements are met, some USB flash drives may not operate correctly. Operation is not guaranteed with all USB flash drives.
- A USB hub cannot be used.
- If the moisture analyzer stops operating normally when a USB flash drive is connected or removed, turn the power of the moisture analyzer on and then off again.

## 16.2. RS-232C

Connector	9-pin D-Sub (male)	
Communication method	EIA RS-232C	
Communication format	Bidirectional asynchronous communication method	
Data transfer rate	Approx. 5 times/second	
Signal format	Baud rate	2400 bps
	Data bits	7 bits
	Parity	Even (when the data bit length is 7 bits)
	Stop bits	1 bit
	Encoding	ASCII encoding

One character format

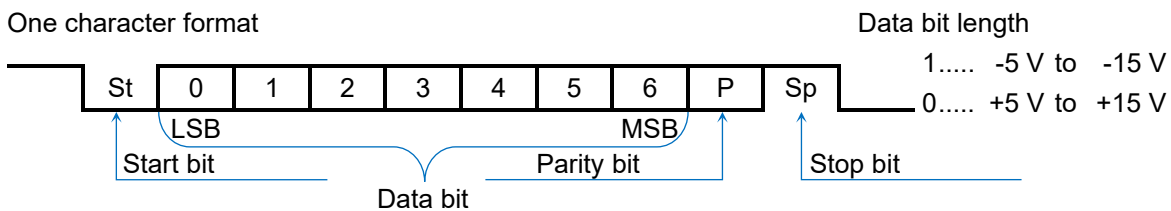

9-pin D-Sub pin layout

Pin no.	Signal name	Direction	Description/Remarks
1	-	-	Same potential as SG <sup>*1</sup>
2	TXD	Output	Sent data
3	RXD	Input	Received data
4	-	-	N.C.
5	SG	-	Signal ground
6	DSR	Output	Data set ready
7	RTS	Input	Request transmission
8	CTS	Output	Allow transmission
9	-	Output	12 V output <sup>*1</sup>

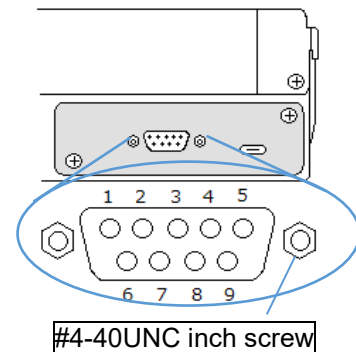

Signal names other than TXD and RXD are the names on the DTE side.

Wiring diagram

(for computer connection)

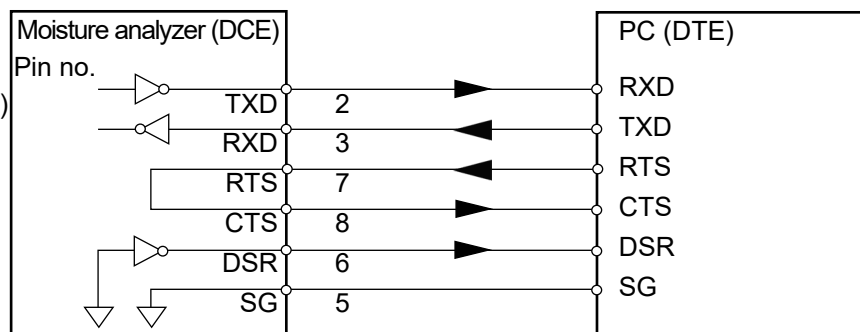

<sup>\*1</sup> Used for some A&D peripherals. Do not wire these pins when connecting to a device from another manufacturer where power is output. Make sure to use a compliant cable, as using an incorrect connection cable may damage the device.

## 16.3. Wired LAN

Connector RJ45  
Protocol TCP/IP

Wired LAN  
terminal

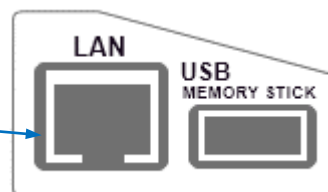

- To use the wired LAN terminal, it must be enabled in [Settings] > [Wired LAN].

### CAUTION

- When connecting the product to a local area network (LAN), contact your system administrator.
- When connecting to a computer directly, use a cross cable. When connecting via a hub, use a straight cable.
- The WinCT-Plus data communication software can be used to collect data. For details on WinCT-Plus, refer to "[17.6.2. WinCT-Plus](#)".

---

### 16.3.1. Network Settings

---

- To connect to a LAN, it is necessary to configure settings such as the IP address and subnet mask of the computer and moisture analyzer.
- When assigning an IP address to the computer and moisture analyzer, contact your network administrator.
- The moisture analyzer is configured as indicated below by default (the port number is fixed).

IP address	Subnet mask	Default gateway	Port number
192.168.0.1	255.255.255.0	00 0.0.0	10001

### CAUTION

- When connecting to an existing network, the moisture analyzer may cause network trouble, so check with your network administrator in advance. Note that A&D will not be held responsible for any network trouble that may occur.

---

## 16.3.2. Computer IP Address Settings

---

- Set the IP address and subnet mask of the computer.
- Open the TCP/IP properties screen, then select the [Use the following IP address] check box and input the IP address and subnet mask.
- For information on the setting values, ask your network administrator.

Example) When directly connecting a computer to one Moisture analyzer, use a cross cable for the LAN cable.

	IP address	Subnet mask
Computer	192.168.0. 12	255.255. 255. 0
Moisture analyzer	192.168.0. 1	255.255. 255. 0

- ✘ Opening the TCP/IP properties screen  
For Windows 10/11  
[Control Panel] > [Network and Internet] > [Network and Sharing Center]  
> [Ethernet] > [Properties] > [Internet Protocol Version 4 (TCP/IPv4)]

## 16.4. Bluetooth

Version	Bluetooth 5.0 (Bluetooth Low Energy)
Profile	HID: Keyboard input (HID connection) GATT: Bidirectional communication
Communication distance	Up to 10 m (line of sight distance)
Frequency band	2.4 GHz

- To use Bluetooth, it must be enabled in [Settings] > [Bluetooth].

### CAUTION

- For keyboard input (HID connection)
  - Perform pairing on the Bluetooth device (such as computer, smartphone, or tablet).
  - Keyboard input (HID connection) is unidirectional communication from the moisture analyzer to the Bluetooth device.
  - Only the numeric values of the displayed values are output.
  - Set the input of the Bluetooth device to single-byte alphanumeric characters.
- For bidirectional communication:
  - The AD8541-PC computer connection dongle (sold separately) can be used to perform bidirectional communication that enables commands to be sent from a computer. It also enables communication with software such as WinCT.
  - For information on how to connect, refer to the instruction manual for AD8541-PC.

## 17. Connecting to a Peripheral

You can use the RS-232C connector, USB Type-C connector, wired LAN connector, or Bluetooth standard-equipped in the moisture analyzer to communicate with peripherals and a computer or PLC, etc.

### 17.1. Cables Used for Connecting to a Peripheral

- "[Peripheral and connection cable compatibility chart](#)" indicates the connection cables compliant with the interfaces used with peripherals.

Peripheral and connection cable compatibility chart

Peripheral		Communication interface used	Connection cable		Remarks
Product name	Product code		Standard/optional	Cable product code	
Multi printer	AD-8127	RS-232C	[Included as standard] RS-232C cable included with printer	AX-KO2741-100	
Thermal printer	AD-8129TH		[Sold separately] RS-232C cable	AX-KO2741-180	*1
Computer		USB Type-C	[Included as standard] USB cable included with moisture analyzer	AX-KO7919-200	
		Wired LAN	[Commercially-available parts] Commercially-available LAN cable		*2

\*1 Uses AX-USB-9P, AD-8541-SCALE, and AD-1688 to connect with the computer.  
When exchanging data, the connection cable included with these products can be used.

\*2 When connecting to a computer directly, use a cross cable.  
When connecting via a hub, use a straight cable.

## 17.2. Printing Mass and Moisture Content Values to a Printer

- The table below indicates internal settings of the moisture analyzer and example printer settings for printing data such as the moisture content.

### 17.2.1. For the AD-8129TH or AD-8127

- The standard RS-232C interface can be used to print measurement results and sensitivity adjustment records supporting GLP/GMP/ISO to a thermal printer (AD-8129TH) or multi printer (AD-8127).
- The functions of the AD-8129TH or AD-8127 can be used to print the drying rate over a fixed period of time and the results of processing statistics about the measurement results.
- Use the cable included with the AD-8129TH or AD-8127 to connect.
- For details on the settings, refer to "[11. Internal Settings](#)" and the instruction manual of the printer.

Setting Correspondence Chart

How to Use	Internal settings of moisture analyzer				AD-8129TH/AD-8127 setting PRN MODE
	Data output mode	Output data selection	Data output interval	GLP output	
Print measurement results including measurement conditions (non-statistical computation)	Key mode Auto print mode	Measurement results only	No interval	Output measurement results all at once Output measurement results separately	DUMP Dump print mode
Print measurement results (statistical computation)	Key mode Auto print mode	Measurement results only	No interval	Off	EXT.KEY External key print mode
Output the drying rate	Stream mode	Measurement results only	No interval	Off	TIMER Interval print mode
GLP/GMP/ISO compatible printing	Key mode Auto print mode	Measurement results only	No interval	Output measurement results all at once Output measurement results separately	DUMP Dump print mode
Output of Results Recorded in Measurement History	Key mode Auto print mode	Measurement results only	No interval	Off Output measurement results all at once Output measurement results separately	DUMP Dump print mode

## 17.3. Connecting to a Computer

### 17.3.1. Virtual COM Mode

---

- The virtual COM mode function enables you to use the included USB cable to connect the moisture analyzer to a computer and create a COM port on the computer to perform bidirectional communication. Operating systems from Windows 7 and later are supported. With Windows 10 and Windows 11, the driver is automatically installed. If the driver is not automatically installed, refer to the PDF file in "Driver for Virtual COM Mode" on the A&D website (<https://www.aandd.jp>).
- By selecting the COM port in software such as the WinCT-Moisture data communication software, you can perform communication equivalent to RS-232C.
- With the virtual COM mode, it is not necessary to configure the baud rate, data bit, parity, and stop bit of the data communication software.

#### Procedure

- Switch [Settings] > [USB communication] > [USB device mode] to [Virtual COM].

#### How to Use

- The  button or a data request command from a computer is used to output the mass value and moisture content from the moisture analyzer.

### CAUTION

- It may take some time to install the driver for the virtual COM mode for the first time.
- The output format is fixed to the standard A&D format.

---

### 17.3.2. Quick USB Mode

---

- The Quick USB mode enables you to connect the moisture analyzer to a computer via a USB cable to directly input the output of the moisture analyzer to computer software such as Excel or Word. Operating systems from Windows 7 and later are supported.
- Because the standard Windows driver (HID) is used, a dedicated driver does not need to be installed and communication can be performed simply by connecting the USB cable.

#### Procedure

- Switch [Settings] > [USB communication] > [USB device mode] to [Quick USB].

#### How to Use

The  button is used to output the mass value and moisture content from the moisture analyzer.

### CAUTION

- The quick USB mode performs one-way communication from the moisture analyzer to the computer. Commands cannot be sent from the computer to the moisture analyzer.
- The output format is fixed to the NU2 format.
- Make sure to disable the screen saver and standby mode of the computer.
- Do not use the quick USB mode when the data output mode of the moisture analyzer is set to the stream mode.

Because the stream mode continuously outputs the mass value from the moisture analyzer to the computer, it may cause the computer to operate in an unexpected manner.

---

### 17.3.3. RS-232C

---

- The RS-232C interface of the moisture analyzer is DCE (Data Communication Equipment) that can connect to a computer. A straight-type RS-232C cable is used to connect.
- If the computer does not have an RS-232C connector, connect it via the virtual COM mode of a USB connector.

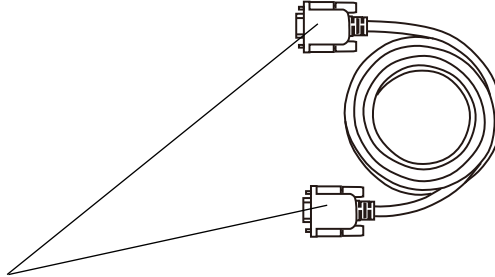

9-pin D-Sub (female), inch screws

---

### 17.3.4. Wired LAN

---

- Refer to "[16.3. Wired LAN](#)".

---

### 17.3.5. Bluetooth

---

- Refer to "[16.4. Bluetooth](#)".

## 17.4. Connecting to a USB Flash Drive

- Refer to "[16.1.2. USB Type-A \(USB host: USB flash drive\)](#)".

## 17.5. WinCT-Moisture Communication Software

- WinCT-Moisture is data communication software for Windows that enables the data of the moisture analyzer to be imported to a computer for saving or data analysis.
- WinCT-Moisture can be downloaded from "Software Downloads" on the A&D website (<https://www.aandd.jp>).
- WinCT-Moisture includes two programs: RsFig and RsTemp.

### 17.5.1. RsFig Graph Software for Moisture Content Measurement

- RsFig is Windows software that enables the data received from the moisture analyzer to be graphed in real-time.
- This enables you to check the drying rate being measured to understand the process by which the moisture content stops changing (the convergence process).
- Graphs can also be overlaid on each other, so when measurement is repeated with different drying temperature conditions, the measurement process can be overlaid on the same graph.
- The measured data can be exported to a CSV file.
- For information on how to change and restrict the settings, refer to the instruction manual for RsTemp (RsFig\_ReadMe).

#### Example Display with RsFig

- The figure below is an example of overlaying the measurement results for sodium tartrate dihydrate on the graph when the drying temperature is changed by 20°C each time (100 to 200°C).
- The horizontal axis is the time elapsed (in minutes) since measurement started and the vertical axis is the moisture content (%).
- The mass of the sample will decrease as the water evaporates due to heating, and that decrease in mass is calculated and displayed as the moisture content. When the moisture content stops changing (when the graph becomes flat), that is the moisture content of the sample.



## CAUTION

- Set [Automatic measurement start] to [Off] in the measurement conditions, because heating will be controlled from the computer.

## 17.5.2. RsTemp Software for Automatic Drying Temperature Detection

- RsTemp is drying temperature detection software that automatically detects the recommended drying temperature when measuring the moisture content of a sample using an A&D moisture analyzer.
- The drying temperature is determined by gradually changing the temperature for heating the sample (in steps) and measuring the moisture content.
- The figure below is an example of measuring a sodium tartrate dihydrate sample with RsTemp.
- The horizontal axis indicates the elapsed time, the red curve in the figure indicates the moisture content, which is the left vertical axis. The green curve in the figure indicates the drying rate (%/min), which is the right vertical axis.
- The moisture content is measured with the drying temperature automatically increased by 20°C every five minutes.
- The starting drying temperature, temperature increase per step, and measurement time per step can be adjusted. (In the figure, the starting drying temperature is set to 100°C, the temperature increase per step is set to 20°C, and the measurement time per step is set to 5 minutes.)
- The table below the graph indicates the drying temperature of each step and the moisture content, drying rate, and recommended temperature level at the end. Recommended temperatures are given in six levels of A to F, where A is the temperature deemed to be the most recommended.



- For information on how to change and restrict the settings, refer to the instruction manual for RsTemp (RsTemp\_ReadMe).

### CAUTION

- Set [Automatic measurement start] to [Off] in the measurement conditions, because heating will be controlled from the computer.
- RsTemp determines the recommended drying temperature based on the measurement and calculated result, but the recommended temperature may not be able to be appropriately determined, depending on the sample type and amount.
- When deciding the drying temperature of the sample, also observe the state of the sample over time (whether it melts, burns, smells, or disintegrates) and use that information to ultimately help decide the optimal drying temperature.



### 17.5.3. RsSetup Software for Moisture Analyzer Settings

- RsSetup is Windows-based setting software that allows the ID number, internal settings, and measurement programs of the moisture analyzer to be changed from a PC.
- The identification information (ID number) of the moisture analyzer can be read, checked, and changed.
- The internal setting data of the moisture analyzer can be read and changed in a batch. The read internal setting data can be saved in CSV file format.
- Internal setting data can be batch read and batch changed, and can also be saved and loaded in CSV format.
- The measurement programs of the moisture analyzer can be read out in a batch and changed in a batch. The read measurement programs can be saved in TSV file format. Copying and pasting by program number is also possible.
- For details on how to change each setting item and the applicable restrictions, refer to the RsSetup instruction manual (RsSetup\_Readme).

### Caution

- This software cannot be used if changing settings is prohibited by the password function of the moisture analyzer.
- Internal settings cannot be applied between different models (for example, writing the settings of the MS-74AT to the MX-53AT).
- Measurement programs can be applied even between different models.

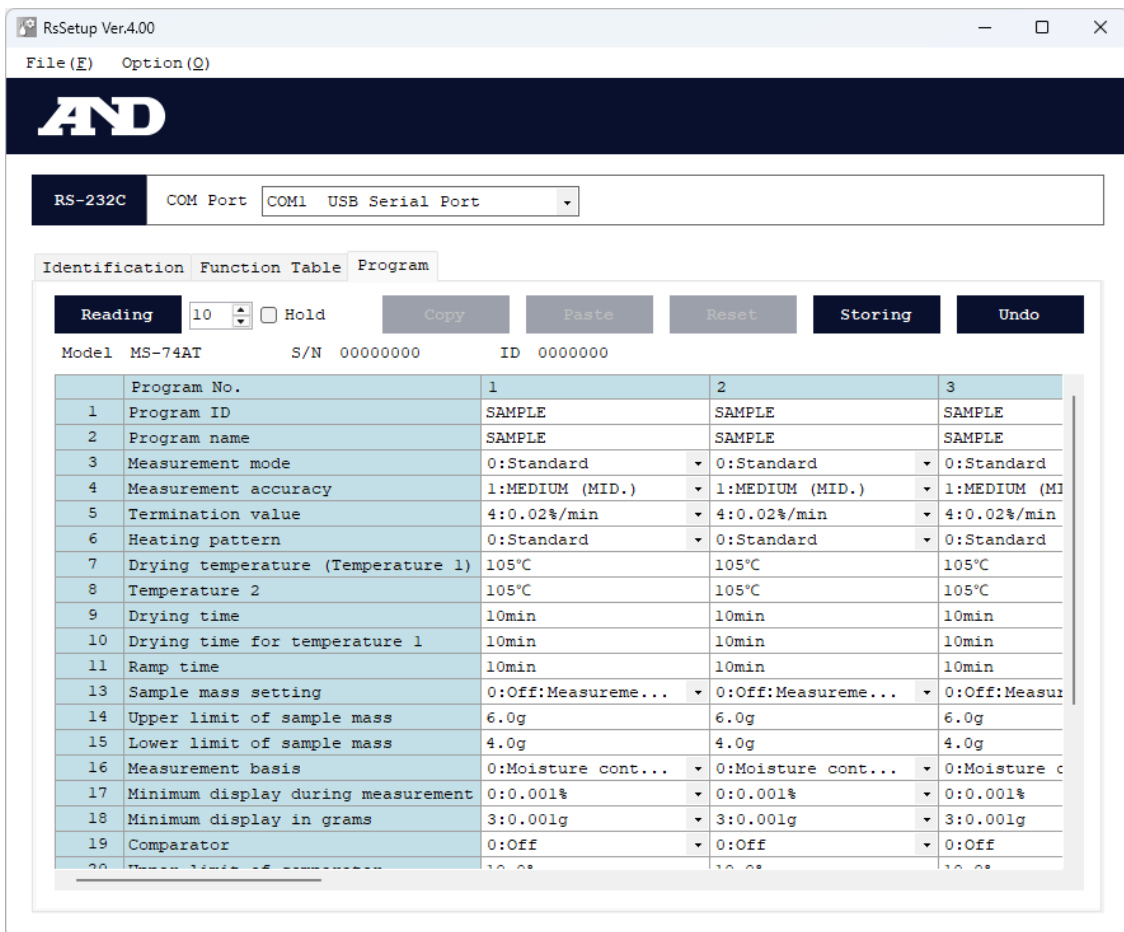

## 17.6. WinCT/WinCT-Plus Data Communication Software

### 17.6.1. WinCT

---

- WinCT is data communication software for Windows that enables the mass and moisture content values of the moisture analyzer to be easily imported to a computer. It uses RS-232C for communication.
- WinCT can be downloaded from "[Software Downloads](https://www.aandd.jp)" on the A&D website (<https://www.aandd.jp>).
- For information on installing and setting up WinCT, see "Setting Up WinCT" and "WinCT Instruction Manual".
- WinCT includes three programs: RsCom, RsKey, and RsWeight.

#### RsCom

- Enables the moisture analyzer to be controlled by sending commands.
- Displays the received data and saves it as a text file (.txt).
- Multiple instances can be executed to communicate with multiple moisture analyzers.
- Can be executed at the same time as other applications. (Does not monopolize the computer.)
- Can also receive the GLP output data of the moisture analyzer.

#### RsKey

- Enables the mass and moisture content values of the moisture analyzer to be directly input to another application.
- Any application such as Word or Excel can be used, as long as it allows keyboard input.
- Can also input the GLP output of the moisture analyzer.
- Enables the test display function to be used to use a computer as an external display for the moisture analyzer. (With the moisture analyzer in the stream mode.)

#### RsWeight

- Graphs received data in real-time.
- Enables the maximum, minimum, average, standard deviation, and coefficient of variation of the received data to be calculated and displayed.

---

### 17.6.2. WinCT-Plus

---

- WinCT-Plus is data communication software for Windows that enables the measurement data of the moisture analyzer to be easily imported to a computer. To communicate with a computer, use a wired LAN connection, virtual COM mode of a USB connection, or bidirectional communication of a Bluetooth connection (using AD-8541-PC), or RS-232C.
- WinCT-Plus can be downloaded from "[Software Downloads](https://www.aandd.jp)" on the A&D website (<https://www.aandd.jp>).
- For information on installing and setting up WinCT-Plus, see "WinCT-Plus" on the A&D website.
- WinCT-Plus includes an application called "RsMulti".

#### RsMulti

- Sends data from multiple moisture analyzers connected to an Ethernet (LAN) to a single computer. You can connect up to 100 moisture analyzers. However, this number may be lower depending on the performance of the computer and the frequency of importing data.
- You can press the  button of the moisture analyzer to send data to a computer.

## 17.7. Commands

- The following commands can be sent from a computer to control the moisture analyzer.
- Add a terminator   (0Dh, 0Ah) to the command before sending it to the moisture analyzer.

List of Commands

Command	Description
Q	Sends one measurement value.
SIR	Continuously sends measurement values.
C	Stops continuously outputting measurement values with the SIR command.
QM	Outputs one measurement value during measurement. QM can only be used during measurement.
START	Starts heating. Performs the same function as the <input type="text" value="Start"/> button.
STOP	Stops heating. Performs the same function as the <input type="text" value="Cancel"/> button.
ZERO	Resets the displayed mass to zero. Performs the same function as the <input type="text" value="Zero"/> button.

## 18. Help and Device Information

### 18.1. Help

Access method: [Home] > [Menu] > [Help]

- The moisture analyzer contains a help function that enables you to check simple operation methods and troubleshooting.
- Detailed help is also provided regarding the program measurement conditions and settings.

#### Help

- Describes the basic operation procedures and configuration methods.

Item	Description
Help: Getting started guide	Contains the following three sections. Handling precautions: Describes precautions for using the product safely. Moisture analyzer installation: Describes how to correctly install the moisture analyzer. Starting the measurement: Describes how to start measurement.
Help: Measurement program	Displays a description of each measurement condition.
Help: Settings	Displays a description of some internal settings.

#### FAQ

- This section includes frequent problems and how to resolve them, as well as frequently asked customer questions and their answers.
- The FAQ includes the following four items.

Item	Description
FAQ: Samples	Displays questions and answers regarding samples.
FAQ: Measurement conditions	Displays questions and answers regarding appropriate measurement conditions.
FAQ: Measurement results	Displays questions and answers regarding the interpretation of measurement results and how to solve problems.
FAQ: Moisture analyzer specifications	Displays questions and answers regarding the technical specifications of the moisture analyzer.

## 18.2. Information

Access method: [Home] > [Menu] > [Information]

Category	Displayed item	Description
Moisture analyzer data	Model name	Displays the model name of the moisture analyzer.
	Serial number	Displays the serial number of the moisture analyzer.
Software version	Touch screen	Displays the software version of the functions operating in the moisture analyzer.
	Weight sensor	
	Bluetooth control CPU	
	Bluetooth module	
Adjustment history		Displays the date/time, user name, and details of heater temperature adjustment and weight sensor sensitivity adjustment. * 1*2
Operation history		The operation history includes the date and time, user name, and settings when the power was turned on and when settings were changed. * 1*2
Login/logout history		Displays the date/time and user name when a login or logout operation was performed. 1*2
License documents		Displays documents describing the rights and terms of use for the software, fonts, and other components used in this product.

\*1 The information is displayed in English.

\*2 The history displays only the most recent 100 items. Up to 1,000 items are saved and can be exported to a USB flash drive as a CSV file (the export button is only available when a USB flash drive is connected). If the number of items exceeds 1,000, the oldest data is deleted and overwritten with the latest data.

## 19. Maintenance

Make sure to remove the power plug from the power outlet before performing maintenance.

Perform operations after confirming that the various parts of the moisture analyzer have cooled down.

The sample pan, pan holder, and breeze break can be removed.

Remove any dirt by wiping it away with a cloth that has been immersed in water or water containing a neutral detergent then wrung out.

Do not use organic solvents or chemical wipes.

Perform assembly as described in "5.1. Installing the Moisture Analyzer" and

"1. Cautions Regarding Handling" after the parts are completely dry.

When transporting the product, use the dedicated packaging box.

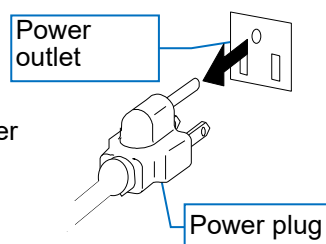

### 19.1. Cleaning the Heater

- Clean the glass housing if it gets dirty, or it may not be able to heat properly. The glass housing can be easily detached by removing the two screws.
- Clean the halogen lamp if it has any fingerprints on it, or its life may be shortened.
- Do not touch the metal plate for reflection on the rear of the halogen lamp. Doing so may cause the set temperature of the sample pan and the actual drying temperature to deviate.
- Do not touch the temperature sensor adjacent to the halogen lamp. Doing so may cause the set temperature of the sample pan and the actual drying temperature to deviate.

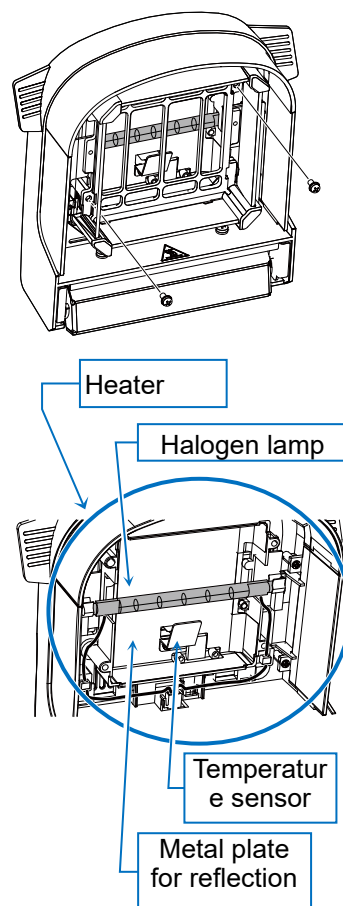
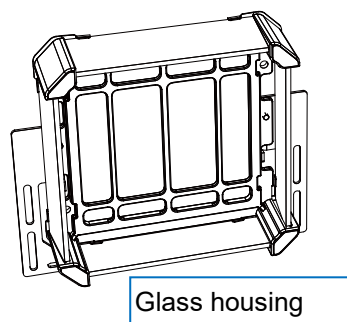

## 19.2. How to Replace the Halogen Lamp

- If heating takes time because the halogen lamp output has decreased due to lamp degradation or the halogen lamp has stopped lighting, replace the halogen lamp. Use the separately-sold halogen lamp that supports your local voltage (AX-MX-34-120V \*1 or AX-MX-34-240V). The rated lifespan of the halogen lamp is approx. 5,000 hours.

### CAUTION

- Performing this procedure without removing the power cable can result in electrocution.
- Read the power supply voltage label on the back of the heater cover and confirm that the rated voltage of the halogen lamp is correct for your power supply voltage.

Voltage	Rated voltage of halogen lamp	Accessory number *1
100 to 120 V	AC120V	AX-MX-34-120V
200 to 240 V	AC240V	AX-MX-34-240V

- Confirm that the area around the glass housing has cooled down before performing work.
- Do not drop, strike, or damage glass parts including the halogen lamp. Doing so may cause it to break and lead to injury due to glass shards.
- The halogen lamp degrades due to contamination on its surface. Do not directly touch the glass of the halogen lamp.
- Dispose of the used halogen lamp as-is. Breaking a halogen lamp can cause glass shards to scatter, which may result in injury.
- It is recommended that you replace the halogen lamp once it has reached its rated life. Continuing to use it may cause damage to the product.

\*1 UL certified products are 120 V only.

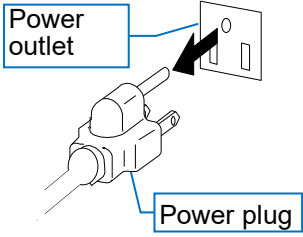
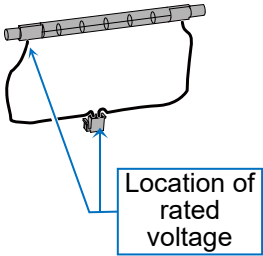
Step	Description	Diagram
1.	Remove the power cable from the power outlet.	
2.	Check the rated voltage of the new halogen lamp. The rated voltage is indicated on the edge of the connector and the halogen lamp.	
3.	Confirm that the heater has sufficiently cooled.	

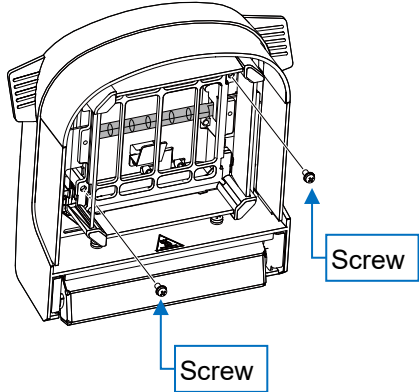
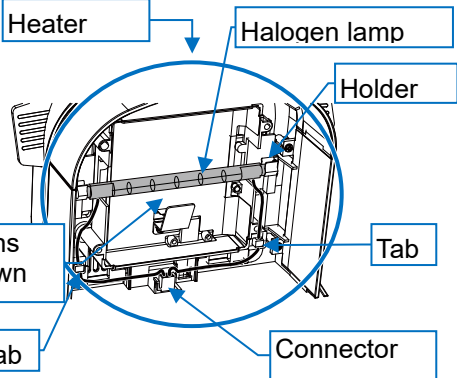
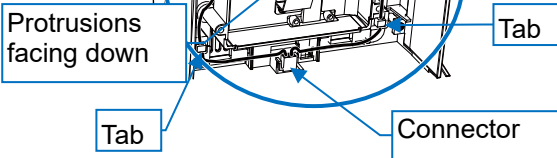
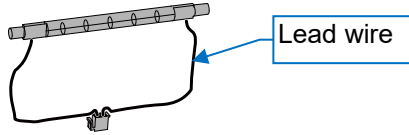
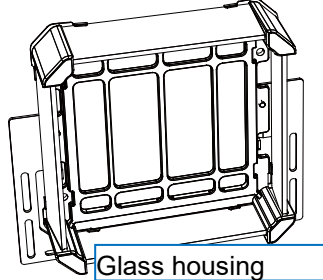
Step	Description	Diagram
4.	Remove the two screws of the glass housing.	 <p>The diagram shows a perspective view of the glass housing assembly. Two screws are indicated with blue arrows and labeled 'Screw' in blue boxes. One screw is located at the bottom center, and the other is on the right side.</p>
5.	Disconnect the connector of the halogen lamp, then remove it from the holder.	 <p>The diagram shows a perspective view of the assembly with a blue circle highlighting the lamp area. Labels include 'Heater' at the top, 'Halogen lamp' in the center, 'Holder' on the right, 'Protrusions facing down' on the left, and 'Connector' at the bottom right. A 'Tab' is also labeled on the right side.</p>
6.	Load the halogen lamp with the protrusions facing down, as indicated in the figure, then connect the connector.	 <p>The diagram shows the halogen lamp being inserted into the holder. The 'Protrusions facing down' are clearly visible. Labels include 'Tab' on the left and 'Connector' on the right.</p>
7.	Hook the lead wire of the halogen lamp on the two tabs (on the left and right).	 <p>The diagram shows a close-up of the lead wire being hooked onto two tabs. The label 'Lead wire' is on the right.</p>
8.	Secure the glass housing with screws so that it does not pinch the lead wire of the lamp.	 <p>The diagram shows the final assembly with the glass housing secured. The label 'Glass housing' is at the bottom.</p>

## 19.3. How to Replace the Power Fuse

The fuse inside the power supply may blow to protect the moisture analyzer main unit in cases such as when a power supply with the wrong voltage is connected. If the fuse blows, replace it with a new fuse (AX-FST6.3A250V; sold separately).

### CAUTION

- Performing this procedure without removing the power cable can result in electrocution.

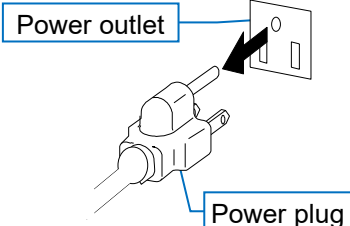
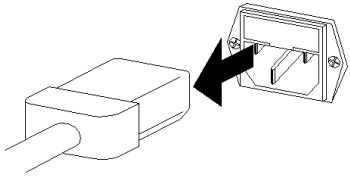
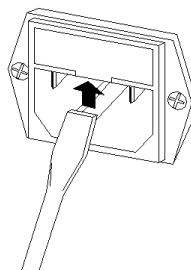
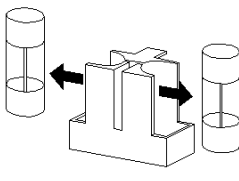
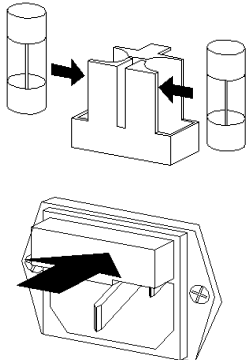
Step	Description	Diagram
1.	Remove the power cable from the power outlet.	
2.	Remove the power cable from the power inlet of the moisture analyzer.	
3.	Use a flat-head screwdriver to remove the fuse cover on the top of the power inlet. (Insert the flat-head screwdriver under the tab on the bottom of the fuse cover, then pries it open to remove the fuse cover.)	
4.	Remove the fuse from the fuse cover, then visually check whether the fuse has blown, or use a multimeter. If the fuse has blown, replace it with a new fuse (sold separately).	
5.	Place the fuse in the fuse cover, then place the fuse cover together with the fuse into the power inlet.	

## 19.4. Factory Settings

- You can initialize the settings of the product to restore the factory defaults.
- There are three initialization methods, which initialize different settings.
- The initialized settings are as follows.

Item	Initialize all	Initialize measurement programs only	Initialize internal settings only
Weight sensor sensitivity adjustment data	Yes	No	No
Heater temperature adjustment data	Yes	No	No
Measurement conditions	Yes	Yes	No
Shortcut	Yes	Yes	No
Internal settings (excluding the password function)	Yes	No	Yes
Device identification number	Yes	No	Yes
Measurement history	Yes	No	No
Adjustment history	No	No	No
Operation history	No	No	No
Login/logout history	No	No	No

Yes: Initialized

No: Not initialized

## 19.5. Troubleshooting

If the measurement results seem incorrect

- Refer to "[10.4. Self-Check Function](#)" to try a self-check.
- With the product switched to the mass display, load and unload the weight to check the repeatability of the mass value. Because a tall weight may touch the heater, use as short a weight as possible. When you have no choice but to use a 50 g weight, perform measurement with the heater cover open. Avoid disturbance such as wind when doing so.
- The maximum height of the weight that can be placed on the sample pan (the height from the sample pan to the glass housing) is approx. 26 mm.
- Check whether the moisture content of the included test samples can be correctly measured (refer to "[10.3. Test Sample Measurement](#)").
- Is the moisture analyzer subject to any (air conditioner) wind or vibrations?  
Place the product on a stable surface and ensure it is not subject to any wind or vibrations.
- Has the measurement sample been appropriately processed?  
For information on cutting samples with large granules or using a glass fiber sheet, refer to "[5.2. Requirements for Ensuring Correct Measurement](#)".
- Has measurement been performed properly?  
For information on preheating before measurement and replacing the pan during continuous measurement, refer to "[5.2. Requirements for Ensuring Correct Measurement](#)".

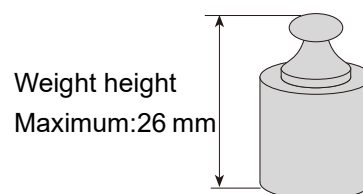

## If the lamp does not light when measurement starts or it takes time to reach the set temperature

- When automatic measurement start is enabled, it normally takes approx. 16 seconds until the lamp lights after the heater cover is closed. This is for waiting for the mass value to stabilize.
- When automatic measurement start is disabled, it normally takes approx. 6 seconds until the lamp lights after the  button is pressed.
- If the heater cover is open, power is not supplied to the halogen lamp.
- The connector of the halogen lamp indicates the compatible voltage. Check the rated voltage.
- Has the fuse blown? Remove the power plug from the power outlet, then check the fuse of the power inlet on the rear of the main unit (see "[19.3. How to Replace the Power Fuse](#)").
- Was measurement performed at a low temperature after performing measurement at a high temperature? The lamp will not light if the temperature of the pan is higher than the set temperature.
- Confirm that the pan has sufficiently cooled before performing measurement.
- Otherwise, the halogen lamp may have expired. Check the filament of the lamp, and replace the lamp if necessary. Refer to "[19.2. How to Replace the Halogen Lamp](#)".
- If a replacement power cable is required, contact the retailer where the product was originally purchased.
- This unit features software-based temperature monitoring with automatic heating shutdown, as well as an independent non-resettable thermal fuse for final overtemperature protection. If the fuse operates, the lamp will no longer heat. Please request repair service.

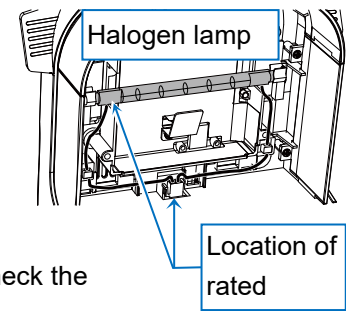

## 19.6. Errors Displayed

Errors Displayed	Description and Example Remedy
E	<p>Overload</p> <p>The sample mass exceeded the allowed range. Reduce the sample.</p> <p>If this error occurs when only the sample pan is loaded, contact A&amp;D for a repair.</p>
-E	<p>Underload</p> <p>The sample is too light. (The output from the weight sensor is too low.)</p> <p>Place the pan holder and sample pan on the product correctly, then press the <b>Zero</b> button.</p> <p>Perform weight sensor sensitivity adjustment.</p> <p>If the problem persists, contact A&amp;D for a repair.</p>
CH no	<p>Self-check error</p> <p>An error occurred during the self-check. Request a repair.</p>
CAL E	<p>Weight sensor sensitivity adjustment weight problem (positive)</p> <p>The weight for weight sensor sensitivity adjustment is too heavy. Check the condition around the sample pan. Confirm that the weight for weight sensor sensitivity adjustment is not touching the glass housing of the heater cover and that the mass of the weight for weight sensor sensitivity adjustment is appropriate. Press any key or wait 15 seconds to return to the mass display.</p>
-CALE	<p>Weight sensor sensitivity adjustment weight problem (negative)</p> <p>The weight for weight sensor sensitivity adjustment is too light. Check the condition around the sample pan. Confirm that the mass of the weight for weight sensor sensitivity adjustment is appropriate. Press any key or wait 15 seconds to return to the mass display.</p>
Error1	<p>Unstable mass value</p> <p>Weight sensor sensitivity adjustment cannot be executed because the mass value is unstable. Inspect the area around the pan.</p> <p>Improve the installation environment (vibrations, wind, temperature changes, electrostatic, magnetism, etc.) so that it does not affect the moisture analyzer.</p> <p>The error will automatically clear in 10 seconds.</p>
t-UP	<p>Heater temperature adjustment data input timeout</p> <p>Indicates that there was no temperature input after waiting for five minutes when adjusting the heater temperature.</p> <p>Press the OK button to clear the error. To adjust the heater temperature, repeat the procedure from the start.</p>
rtc PF	<p>Internal clock battery error</p> <p>Press any key, then enter the date and time.</p> <p>Refer to "<a href="#">11.2. Description of Clock Adjustment</a>".</p> <p>If the problem persists, request a repair.</p>
rtc Err	<p>Internal clock malfunction</p> <p>Request a repair.</p>
Error0	<p>Internal error</p> <p>Turn the power OFF then ON again.</p> <p>If the error occurs again, request a repair.</p>
Error3 Error8 Error9	<p>IC error</p> <p>Request a repair.</p>
Ht Err	<p>Temperature control error</p> <p>Try again after turning the power OFF and waiting for at least 30 minutes. If the error occurs again, request a repair.</p>

Errors Displayed	Description and Example Remedy
LoWVoLt	AC power voltage error Check the power supply voltage. The voltage may drop if a power strip is used to share the power supply with other devices.
FrEQErr	AC power frequency error Check if the power supply being used is appropriate.

## 20. Disposal

Due to the requirements of the European Directive on Waste Electrical and Electronic Equipment (WEEE) 2012/19/EU, the product must not be disposed of as general waste. Follow the local laws when disposing of the product.

Dispose of the product according to the local regulations on recycling electrical and electronic devices. If you have any questions, contact the relevant local government office. Make sure to convey these disposal requirements if transferring the product to a new owner.

## 21. Specifications

		MS-74AT	MX-53AT
Heating method		400 W halogen lamp	
Range of sample pan temperature settings		30°C to 200°C (1°C increments)	
Sample pan heating patterns		Standard heating, ramp heating, step heating, quick heating	
Heater temperature adjustment		Available with separate temperature adjustment kit (AX-MXA-43; sold separately)	
Measurable sample mass		0.1 g to 71 g	0.1 g to 51 g
Minimum displayed	Moisture content	0.001 %, 0.01 %, 0.1 %	0.01 %, 0.1 %
	Weight	0.0001 g	0.001 g
Measurement accuracy Reproducibility Standard deviation	Moisture content <sup>*1</sup>	Sample mass 5 g or more	0.01 %
		Sample mass 1 g or more	0.05 %
	Weight	0.0002 g	0.001 g
Measurement conditions	Measurement mode	Standard mode	The sample mass and termination value <sup>*2</sup> are automatically determined according to the measurement accuracy, then measurement stops when the termination value is reached.
		Timer mode	Measures moisture content by heating for a certain period of time. (1 to 480 min)
		Custom mode	Enables the user to configure detailed measurement conditions. Measurement ends when the set termination value <sup>*2</sup> is reached.
	Measurement basis	Moisture content (standard before heating), moisture content (Atro, standard after heating), solid content, ratio, grams	
	Recordable measurement conditions	300 sets	
Recordable measurement results (data memory function)		3000	
Display		5-inch WVGA TFT color LCD display	
Interfaces	RS-232C	9-pin D-Sub (male) EIA RS-232C	
	USB(Device)	Type-C (female) USB 2.0 HID CDC	
	USB(Host)	Type-A(female) USB flash drive only	
	Wired LAN	RJ45 TCP/IP port number: 10001 (fixed)	
	Bluetooth	Bluetooth 5.0 (Bluetooth Low Energy) <sup>*5</sup>	
Sample pan dimensions		φ90 mm	
Operating temperature and humidity		5°C to 40°C; Humidity: 85 % or lower RH (without condensation)	
Usage range		Indoor use only	
Elevation		Maximum: 2000 m	
Power supply		120 V AC version: 100 V to 120V, 50/60 Hz, 3A 240 V AC version: 200 V to 240V, 50/60 Hz, 1.5A <sup>*4</sup> Voltage fluctuations: -15%, +10% Power load: Approximately 500 W <sup>*3</sup>	
Overvoltage category		II	
Pollution level		2	
Maximum power consumption		500 W	

	MS-74AT	MX-53AT
External Dimensions	215 (W) × 380 (D) × 176 (H)	
Main unit weight	Approx. 6 kg (excluding accessories)	

- \*1 The result of performing preheating then measuring the included test sample (approx. 5 g of sodium tartrate dihydrate) at 160°C with standard heating and the standard mode ( **MEDIUM.** ) and cooling for 15 minutes at room temperature with the heater cover raised after each measurement.
- \*2 Measurement stops when the drying rate over time is at or below the set value.
- \*3 Confirm that the moisture analyzer is compatible with your local voltage, outlet type, and power cable.
- \*4 UL certified products are 120 V only.
- \*5 The Bluetooth function is currently enabled for the US, Canada, Australia and Japan only.

## List of Included Accessories

Yes Included as standard; -

Available for purchase

	MS-74AT	MX-53AT
Pan holder	Yes	Yes
Breeze break	Yes	Yes
Display protective cover	Yes	Yes
Power cable	Yes	Yes
Quick Start Guide	Yes	Yes
Warranty	Yes	Yes
Main unit cover	Yes	Yes
Test sample *1	Yes	Yes
Glass fiber sheet	×100	×100
Spoon	Yes	Yes
Tweezers	Yes	Yes
USB cable	Yes *2	Yes *2
Sample pan	× 20	× 20
Sample pan handle	× 2	× 2
Disposable aluminum pan	× 100	× 100

Yes: Included; -: Not included

\*1 30 g of sodium tartrate dihydrate

\*2 UL certified products do not include a USB cable.

## 21.1. External Dimensions

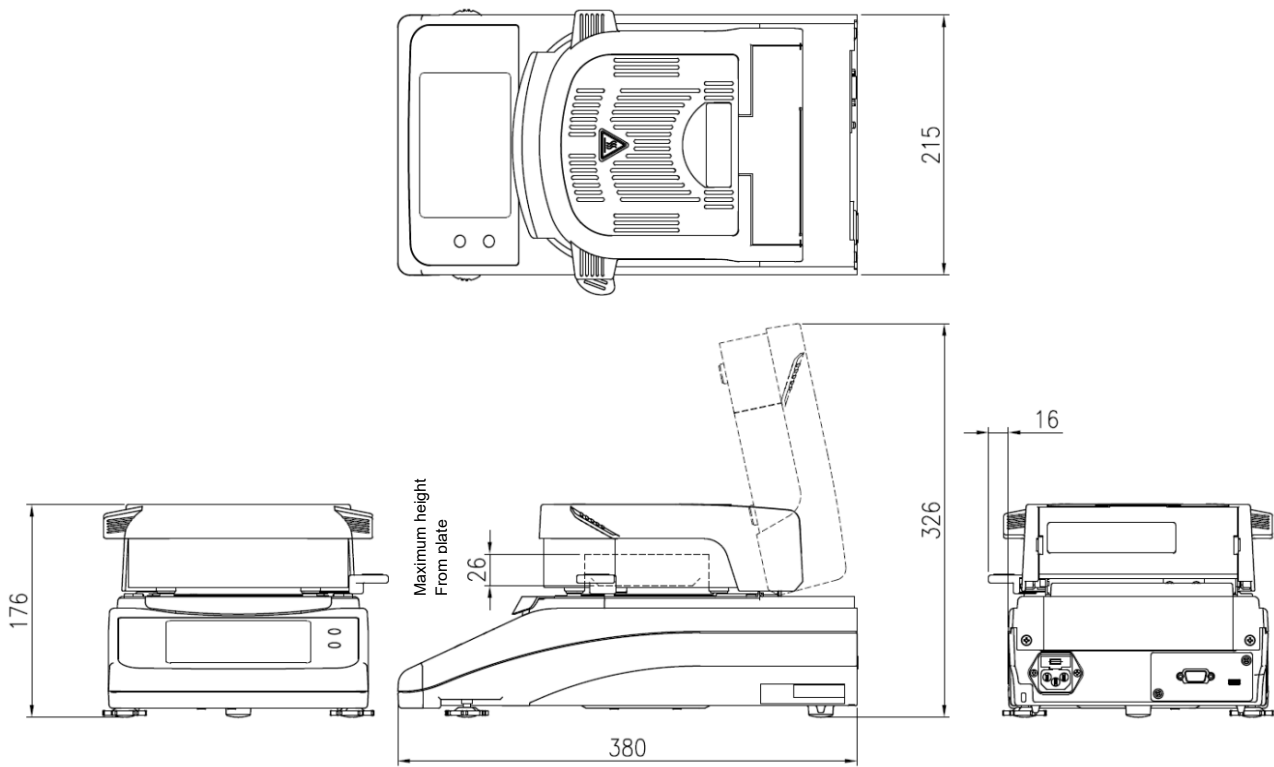

Unit: mm

## 22. Accessories (Sold Separately)

### Accessory

Name	Number
Disposable aluminum pan (φ90 mm, set of 100)	AX-MXA-30
Sample pan (φ90 mm, set of 100)	AX-MXA-31
Glass fiber sheet φ70 mm (filter paper, set of 100) Use for liquid samples with high surface tension.	AX-MX-32-1
Glass fiber sheet φ86 mm (glass paper, set of 100) The same as that included with the MS-74A and MX-53A. Use for liquid samples.	AX-MXA-32-2
Test samples (sodium tartrate dihydrate; 30 g × 12 sets)	AX-MX-33
Halogen lamp (100 V to 120 V)	AX-MX-34-120V
Halogen lamp (200 V to 240 V)	AX-MX-34-240V *1
Sample pan handle (set of two)	AX-MXA-35
Tweezers (set of two)	AX-MX-36
Spoon (set of two)	AX-MX-37
Display protective cover for touch panel (set of five)	AX-MXAT-38
Main unit cover	AX-MXA-39
Weight sensor sensitivity adjustment weight (20 g; OIML F1 class accuracy)	AD1603-20F1
Temperature adjustment kit (with calibration certificate)	AX-MXA-43
Fuse (T6.3 A 250 V)	AX-FST6.3A250V

\*1 UL certified products are 120 V only.

### List of Accessories Available Separately

#### AD-8129TH: Thermal printer

- Multifunctional
- Statistical computation, calendar/clock function, interval print function (prints at a certain interval from 5 sec to 30 min), chart print function (prints the specified two digits in graph format), dump print mode
- 13 × 28 dots; 24 characters per line
- Thermal paper AX-PP147-S (57.5 mm (W) × approx. 30 m)  
Dust-free thermal paper AX-PP183-S (57 mm (W) × approx. 25 m)

#### AD-1687: Environment logger

- Four environment sensors (temperature, humidity, air pressure, and vibration) are included to enable simultaneous measurement and recording with standalone operation. By connecting with the RS-232C output of the moisture analyzer, the mass value can be recorded together with the environment data. Dedicated data importing software is not required.

**AD-1688: Weighing data logger**

- Enables data output from the RS-232C port to be recorded. This enables mass and moisture content values to be saved in environments where a computer cannot be used. Dedicated data importing software is not required.

**AD-8526: Ethernet converter**

- Enables management of weight values using an Ethernet network, via a LAN port and the RS-232C port of a weighing device.
- Includes the WinCT-Plus data communication software

**AX-USB-9P: USB converter**

- Enables serial communication software such as WinCT to be used with a USB connection, even on a computer without a COM port. Bidirectional communication can be performed after the driver is installed.

**AX-KO2741-180: 1.8 m RS-232C cable (9-pin D-Sub (female) to 9-pin D-Sub (female))**

- A cable for connecting the moisture analyzer to a computer/PLC, etc.

**AD-1683A: Ionizer**

- Prevents weighing error caused by static electricity during measurement via static elimination. Optimal for precise weighing of samples such as powders because it is a direct flow-type ionizer that does not emit wind.
- It is compact and lightweight.

**AD-1684A: Non-contact electrostatic measuring instrument**

- Displays the result of measuring the charge (of an automatic measurement line, etc.) of moisture analyzer peripherals such as the measured sample, tare, or breeze break. AD-1683A (static eliminator) can be used to remove an electrostatic charge from the product.

**AD-1689: Tweezers for analysis operations**

- Tweezers for retaining the 1 g to 500 g weight used for the weight sensor sensitivity adjustment of the moisture analyzer.
- The tweezers are 210 mm long and feature a cap on the end.

**AX-TWEEZERS-25: Tweezers for analysis operations**

- Tweezers for retaining the 1 g to 500 g weight used for the weight sensor sensitivity adjustment of the moisture analyzer.
- The end features a cap made of polycarbonate + 10% carbon + 10% glass fiber materials, which makes it less susceptible to electrostatic.

**AD-1603-20F1: Weight sensor sensitivity adjustment weight**

- A 20 g OIML shape F1 class weight.

**AD-8541-PC: Bluetooth® dongle for connecting a computer**

- Enables bidirectional communication between the AD-8541-SCALE and a computer via the COM port using Bluetooth.  
Maximum communication distance: Approx. 10 m  
(For details, refer to "[AD-8541-PC Instruction Manual](#)".)

## AD-8541-SCALE: Bluetooth® converter for connecting a scale

- ❑ Enables wireless communication via Bluetooth with a Bluetooth device such as a smartphone/tablet, computer, external Bluetooth display, or the AD-8931-JA or AD-8541-PC.  
Maximum communication distance: Approx. 10 m  
(For details, refer to "[AD-8541-SCALE- Instruction Manual](#)".)

## 23. Precautions Regarding Electromagnetism

- Wireless communication uses EC2832 (Kaga FEI)/Bluetooth 5.0 (Bluetooth Low Energy).
- This product contains radio equipment that has received construction design certification under the Radio Law as a low-power data communication system radio station.  EC2832 : 005-103090
- The frequency band used by this product is shared with on-premises radio stations for mobile identification, specified low-power radio stations, and amateur radio stations.
- Before using the product, confirm that no on-premises radio stations for mobile identification or other stations are being operated in the vicinity.
- If the product happens to adversely affect an on-premises radio stations for mobile identification, swiftly change the frequency used or stop the product from emitting electromagnetism and implement measures to prevent interference.
- Types of electromagnetism and distance of interference

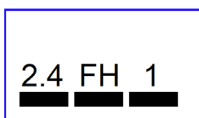

2.4: Indicates radio equipment that uses the 2.4 GHz band.

FH: Indicates that FH-SS is used as the modulation method.

1: Indicates that the expected interference distance is 10 m or less.

 : Indicates that all bands are used and that the band used for mobile identification cannot be avoided.

- When using the product, perform communication with a line-of-sight distance of 10 m or less.
- The communication distance will be shorter in some usage environments, such as those with walls or other obstructions.
- Using the device near the following devices that use the same 2.4 GHz band as Bluetooth may cause interference.
  - Wireless LAN
  - Bluetooth devices (such as mobile phones)
  - Household appliances such as microwaves
- The communication of this product may not be able to maintained, depending on the surrounding environment and device environment. Therefore, it is not suitable for use that requires reliability.







[This page intentionally left blank]



### **A&D Company, Limited**

3-23-14 Higashi-Ikebukuro, Toshima-ku, Tokyo 170-0013, JAPAN  
Telephone: [81] (3) 5391-6132 Fax: [81] (3) 5391-1566

### **A&D ENGINEERING, INC.**

Headquarters Office: 4622 Runway Boulevard, Ann Arbor, Michigan 48108, U.S.A.  
Sales Office: 47747 Warm Springs Boulevard, Fremont, California 94539, U.S.A.  
Tel: [1] (800) 726-3364 Weighing Support: [1] (888) 726-5931 Inspection Support: [1] (855) 332-8815

### **A&D INSTRUMENTS LIMITED**

Unit 24/26 Blacklands Way, Abingdon Business Park, Abingdon, Oxfordshire OX14 1DY United Kingdom  
Telephone: [44] (1235) 550420 Fax: [44] (1235) 550485

### **A&D AUSTRALASIA PTY LTD**

32 Dew Street, Thebarton, South Australia 5031, AUSTRALIA  
Telephone: [61] (8) 8301-8100 Fax: [61] (8) 8352-7409

### **A&D KOREA Limited**

한국에이.엔.디(주)  
서울특별시 영등포구 국제금융로6길33 (여의도동) 맨하탄빌딩 817 우편 번호 07331  
( 817, Manhattan Bldg., 33. Gukjegeumyung-ro 6-gil, Yeongdeungpo-gu, Seoul, 07331 Korea )  
전화: [82] (2) 780-4101 팩스: [82] (2) 782-4264

### **ООО A&D RUS**

ООО "ЭЙ энд ДИ РУС"  
Почтовый адрес: 121357, Российская Федерация, г.Москва, ул. Вере́йская, дом 17  
Юридический адрес: 117556 г. Москва, Варшавское шоссе, д. 95, корп. 1.  
тел.: [7] (495) 937-33-44 факс: [7] (495) 937-55-66

### **A&D Instruments India Private Limited**

ऐ&डी इन्स्ट्रुमेंट्स इण्डिया प्रा० लिमिटेड  
D-48, उद्योग विहार , फेस -5, गूडगांव - 122016, हरियाणा , भारत  
( D-48, Udyog Vihar, Phase-V, Gurgaon - 122016, Haryana, India )  
फोन : [91] (124) 4715555 फैक्स : [91] (124) 4715599

### **A&D SCIENTECH TAIWAN LIMITED.**

艾安得股份有限公司  
台湾台北市中山區南京東路 2 段 206 號 11 樓之 2  
( 11F-2, No.206, Sec.2, Nanjing E.Rd., Zhongshan Dist., Taipei City 10489, Taiwan, R.O.C. )  
Tel : [886](02) 2322-4722 Fax : [886](02) 2392-1794

### **A&D INSTRUMENTS (THAILAND) LIMITED**

บริษัท เอ แอนด์ ดี อินสตรูमेंท์ (ไทยแลนด์) จำกัด  
168/16 หมู่ที่ 1 ตำบลรังสิต อำเภอธัญบุรี จังหวัดปทุมธานี 12110 ประเทศไทย  
( 168/16 Moo 1, Rangsit, Thanyaburi, Pathumthani 12110 Thailand )  
Tel : [66] 20038911