

MS-74A / MX-53A / MF-53A / ML-53A

INSTRUCTION MANUAL

Heat Drying Moisture Analyzer

MS-74A

MX-53A

MF-53A

ML-53A



Please see the materials
(incl. samples) [here](#)





AND
A&D Company, Ltd.

Notation for Precautions

Meaning of Warning Signs

 WARNING	Indicates information where incorrectly handling the product may lead to death or serious injury.
 CAUTION	Indicates information where incorrectly handling the product may lead to injury or damage to property.

Meaning of Symbols

	The  symbol indicates an action that is required. Details on the action are indicated inside the  or in nearby documents or pictures.
---	---

Other

CAUTION	Indicates cautionary information regarding the correct use of the product.
ADVICE	Indicates general advice regarding the use of the product and what to do when a mistake is made.
	Indicates a high temperature caution.

CAUTION

- (1) This instruction manual (hereinafter "this manual") may not be copied, duplicated, modified, or translated, in full or in part, without the written permission of A&D Company, Limited (hereinafter "A&D").
- (2) The content of this manual is subject to change without notice.
- (3) If you have any questions regarding the content of this manual or notice any errors or missing information, please contact A&D.
- (4) A&D shall assume no responsibility for any direct, indirect, special, or consequential damages arising due to flaws in the product or damages or loss of profit caused by the use of the product, even if it is notified of the possibility of those damages occurring in advance. A&D shall also assume no responsibility for claims of rights by third parties. A&D shall assume no responsibility for the loss of any software or data.

©2025 A&D Company, Limited

- Microsoft®, Windows®, Word®, and Excel® are trademarks of the Microsoft Group.
- The Bluetooth® word mark and logos are registered trademarks owned by Bluetooth SIG, Inc. and any use of such marks by A&D is under license.
- Other product names and company names in this manual are trademarks or registered trademarks of their respective owners in Japan and other countries.

Contents

1. Cautions Regarding Handling	6
1.1. Cautions Regarding Installation	7
1.2. Cautions Regarding Use	8
1.3. Cautions After Use and Cautions Regarding Storage.....	11
2. Product Overview/Features	12
3. Content of Package and Names of Parts	14
3.1. Key Switches and Indicators	16
4. Requirements for Preparing to Measure (Installation, Initial Configuration, and Measurement)	18
4.1. Installing the Moisture Analyzer	18
4.2. Requirements for Ensuring Correct Measurement	21
4.2.1. Handling Samples	21
4.2.2. Requirements for the Operation Procedure	21
4.2.3. How to Use the Preheat Function	22
4.2.4. Using a Glass Fiber Sheet	24
5. Measurement	28
5.1. Procedure for Measuring the Moisture Content	28
6. Measurement Conditions	32
6.1. How to Select a Program Number	33
6.2. Example Measurement Conditions	34
6.2.1. List of Example Measurement Conditions and Actual Measurement Results	34
6.2.2. How to Use Example Measurement Conditions	48
6.3. Overview of Measurement Conditions	49
6.3.1. List of Measurement Conditions	49
6.3.2. Available Measurement Conditions	50
6.3.3. Default Setting.....	50
6.4. Detailed Description of Measurement Conditions	51
6.4.1. How to Select Measurement Conditions.....	51
6.4.2. Measurement Modes	52
6.4.3. Heating Pattern	53
6.4.4. Temperature and Time	54
6.4.5. Measurement Accuracy	56
6.4.6. Termination value	57
6.4.7. Configuring the Sample Mass.....	58
6.4.8. Measurement Basis	60
6.4.9. Minimum Displayed (Percentage/Grams).....	61
6.4.10. Comparator Values	62
6.4.11. Correction of measurement results.....	65
6.4.12. Program ID.....	67
6.5. Examples of Changing the Measurement Conditions	68
6.5.1. Example 1 (Standard Conditions).....	68
6.5.2. Example 2 (Complex Conditions)	72

7.	Function Tests and Adjustment	81
7.1.	Function Tests and Adjustment Modes	81
7.2.	Test Sample Function Check	82
7.3.	RS TEMP (Heating Temperature Detection Function)	84
7.4.	Self-Inspection.....	88
7.5.	Adjusting the Sensitivity of the Mass Sensor	90
7.6.	Adjusting the Heating Temperature	92
8.	Internal Settings	96
8.1.	Procedure	96
8.2.	List of Items	99
8.3.	Description of Environment/Display Settings	101
8.4.	Checking and Configuring the Date/Time	102
8.5.	Additional Functions for Measurement Conditions	107
8.6.	Description of Data Output.....	108
8.6.1.	Data Output Mode.....	108
8.6.2.	Data Format	109
8.6.3.	Example Output for Data Format	110
9.	GLP and ID Numbers.....	112
9.1.	Main Uses	112
9.2.	Configuring the ID Number	113
9.3.	GLP output	115
9.3.1.	Example Measurement Result Output.....	117
9.3.2.	Description of Printed Information.....	124
9.3.3.	Test Sample Output for Function Check	127
9.3.4.	Mass Sensor Output for Sensitivity Adjustment.....	128
9.3.5.	Output for Heating Temperature Adjustment	129
10.	Data Memory Function.....	130
10.1.	Preparations	130
10.2.	Batch Output of Recorded Results.....	132
10.3.	Batch Erasure of Recorded Results.....	134
11.	Password Function	136
11.1.	Preparing the Password Function	138
11.2.	Registering (Changing) the Password	140
11.3.	How to Log In	143
11.4.	How to Log Out	146
11.5.	How to Delete a User (USER) Password.....	146
11.6.	If the Administrator (ADMIN) Password Is Forgotten	148
12.	Interface Specifications.....	149
12.1.	USB	149
12.2.	RS-232C.....	150
13.	Connecting to a Peripheral	151
13.1.	Cables Used for Connecting to a Peripheral.....	151
13.2.	Printing Mass and Moisture Content Values to a Printer	152

13.2.1.	For the AD-8127 or AD-8129TH.....	152
13.3.	Connecting to a Computer	153
13.3.1.	Virtual COM Mode.....	153
13.3.2.	Quick USB Mode.....	158
13.3.3.	RS-232C	162
13.4.	WinCT-Moisture Communication Software	163
13.4.1.	RsFig Graph Software for Moisture Content Measurement	163
13.4.2.	RsTemp Software for Automatic Heating Temperature Detection	164
13.4.3.	RsSetup Software for Moisture Analyzer Settings	166
13.5.	WinCT Data Communication Software	167
13.6.	Commands	168
14.	How to Check the Software Version of the Moisture Analyzer.....	169
15.	Maintenance.....	170
15.1.	Cleaning the Heater	170
15.2.	How to Replace the Halogen Lamp	171
15.3.	How to Replace the Power Fuse.....	173
15.4.	Initializing the Settings.....	174
15.4.1.	How to Initialize (Internal Settings)	175
15.4.2.	How to Initialize (All Settings)	177
15.5.	Troubleshooting.....	179
15.6.	Errors Displayed.....	180
16.	Disposal	182
17.	Specifications	183
17.1.	External Dimensions	185
18.	Accessories (Sold Separately).....	186

1. Cautions Regarding Handling

Safety Information

This product is a moisture analyzer based on the principles of thermal mass analysis. It measures properties such as the moisture content and solids in a sample based on changes in mass caused by heating and drying the sample with a halogen lamp to vaporize the moisture. Do not use it for other purposes.

This manual contains basic information on handling the product. Read it thoroughly before using the product.

The product is designed to be used by an experienced operator.

Using the product in a manner not described in this manual, such as modifying, disassembling, or misusing the product, may be dangerous.

A&D shall not be held responsible for this in any way.

1.1. Cautions Regarding Installation

⚠️ WARNING

Danger of death due to fire or explosion

- Perform measurement in an appropriate environment.
 - ❑ Do not use the product in a dangerous environment, such as in an atmosphere of flammable gas.
 - ❑ Ensure that the product is installed in an environment with the following temperature and humidity.
Temperature: 5 to 40°C; Humidity: 85% or lower RH (without condensation)
 - ❑ Do not use the product in a poorly ventilated environment. Using the product in an environment that hinders the dissipation of heat from the moisture analyzer, such as a sealed environment, may cause unexpected rises in temperature or symptoms of poisoning.
- **⚠️** Do not place flammable objects in the vicinity of the product.
 - ❑ The various parts of the moisture analyzer will be at a high temperature during measurement and immediately after measurement, and this can cause objects to catch fire.
 - ❑ Never place objects on the heater cover.
 - ❑ Do not operate the product with any cables or other objects on it.

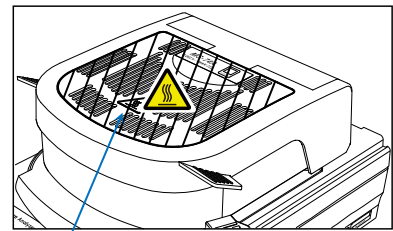

Heater cover

⚠️ WARNING

Danger of death or failure due to electrocution

- Check the power supply voltage.
The compatible power supply voltage is indicated on the rear of the moisture analyzer.
Confirm that it matches the power supply voltage you are using.
- When connecting the moisture analyzer to the power supply, use the included power cable.
- Ground the moisture analyzer.
- Beware of water leaks. The moisture analyzer is not waterproof.
Electrocution or failure may occur if water enters the inside of the moisture analyzer.

Grounding Method
Grounding with the power

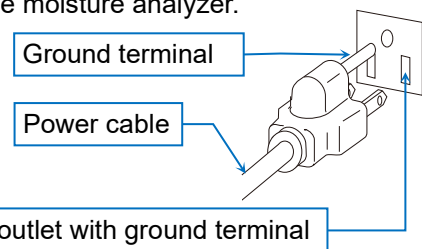

⚠️ CAUTION

To ensure correct measurement

- Note the following regarding the high-accuracy electromagnetic balance type mass sensor used by the product.
 - ❑ Install the product on a robust platform (table).
 - ❑ Avoid vibrations.
 - ❑ Install the product in a location where it will not be exposed to air from an air conditioner, etc.

1.2. Cautions Regarding Use

WARNING

Danger of death due to fire, explosion, or poisoning

- Do not measure dangerous samples.
 - ❑ Do not heat samples that are prone to explosion or combustion or heat samples that emit hazardous substances, as doing so is extremely dangerous. Samples with unknown properties are just as dangerous.
 - ❑ If the internal pressure of the sample rises because the surface dries first, the sample may rupture. Do not perform measurement in this case, as it is dangerous.
 - ❑ If the sample catches fire, immediately remove the power cable from the power outlet, and perform the appropriate procedures.
The case of the moisture analyzer uses flame-retardant material (UL94V-0).
 - ❑ Do not place flammable objects in the vicinity of the product.
 - ❑ The various parts of the moisture analyzer will be at a high temperature during measurement and immediately after measurement.
Do not place flammable objects in the vicinity of the product, as doing so may cause a fire.
 - ❑ Never place objects on the heater cover.

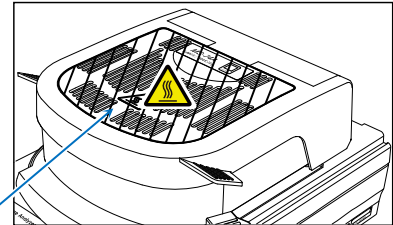

Heater cover

WARNING

Danger of blindness

- Do not look directly at the halogen lamp during heating. Doing so may cause eye pain or vision problems.
- When performing measurement, wear appropriate protective gear, such as goggles and gloves.
- Do not modify or disassemble the moisture analyzer. Doing so may cause failure, electrocution, or fire. If you suspect that the product has failed, contact your place of purchase.
- Do not expose the moisture analyzer, power cable, or accessories to extreme temperatures, intense chemical vapors, humidity, impacts, vibrations, or strong magnetic fields. Follow the operating conditions listed in "[17. Specifications](#)".

⚠ CAUTION

⚠ Danger of burns caused by high temperature surfaces

- Make sure to follow the correct operation methods and procedures.
 - ❑ Make sure to place the breeze brake, tray holder, sample tray, and sample tray handle correctly.
 - ❑ Make sure to hold the heater cover handle when opening or closing the heater cover.

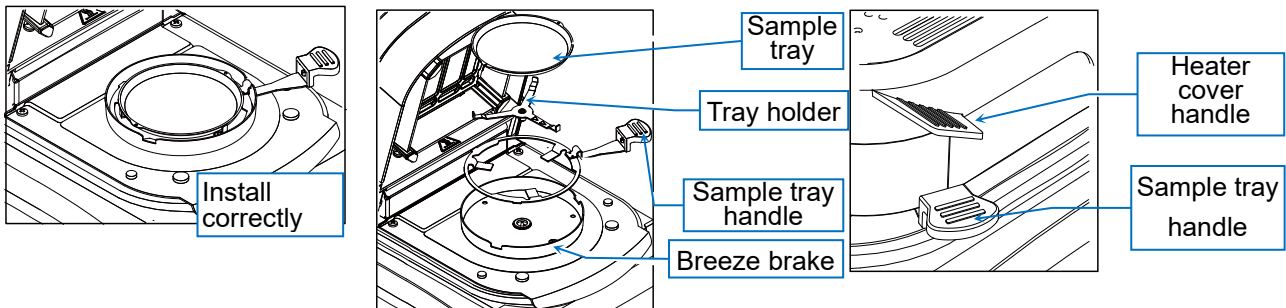

- ❑ The areas with diagonal lines will be at a high temperature during measurement. Only touch the heater cover handle and sample tray handle when operating the product.

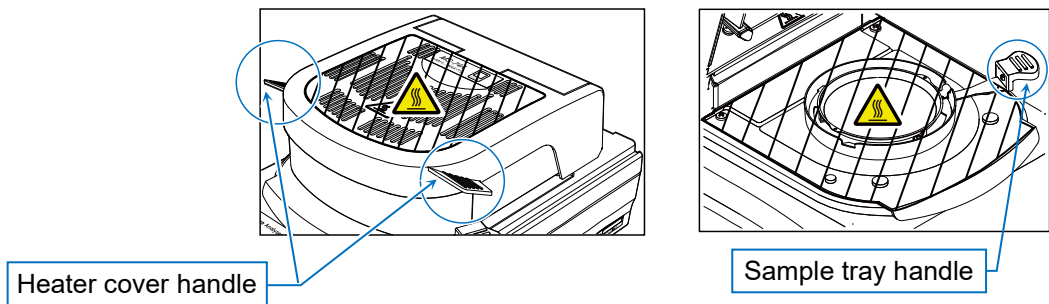

- ❑ Do not touch the high temperature parts such as the inside of the heater cover or sample tray with your hands immediately after heating. Doing so may cause burns. The product will be at a high temperature during measurement and immediately after measurement. When touching the moisture analyzer, make sure to use the specified handle and included tool, and avoid touching the glass housing and the glass and metal (aluminum) parts near the halogen lamp (heater).

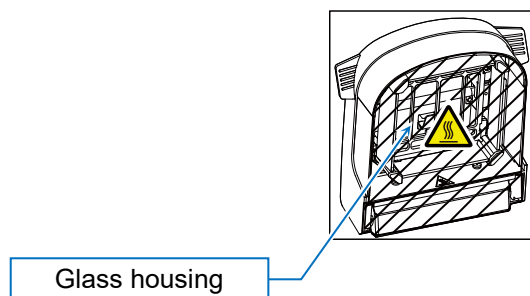

- ❑ The aforementioned glass housing is at a particularly high temperature and can cause burns if you touch it directly.
- ❑ The sample tray and sample tray handle will be at a high temperature immediately after measurement. Cool them in an appropriate location. Use tweezers, etc. when grasping the sample tray.

CAUTION

Danger of injury due to inappropriate handling

- Dispose of the used halogen lamp as-is.
Breaking the halogen lamp can cause glass shards to scatter, which may result in injury.
- Do not drop, strike, or damage glass parts including the halogen lamp.
Doing so may cause them to break and result in injury.
- The edges of the sample tray are sharp. Take care not to cut your hands.
- Make sure to hold the heater cover handle when opening or closing the heater cover, and take care not to get your hands caught.
- When moving the moisture analyzer, make sure it has cooled down and lift it directly up without tilting it.
Moving it tilted may cause the heater cover to unexpectedly open and result in injury.

CAUTION

Danger of device failure due to inappropriate handling

- It is recommended that you replace the halogen lamp once it has reached its rated life (approx. 5,000 hours), as it may break.
- Do not drop, strike, or damage glass parts including the halogen lamp.
Doing so may cause them to break.
- Do not allow dust or water to enter the inside of the moisture analyzer.
- Only use accessories and parts manufactured by A&D.
- If the moisture analyzer behaves in an unexpected manner, try removing the power cable from the power outlet and reconnecting it.
If the product still does not operate normally, request a repair.

CAUTION

- Caution regarding high temperature heating
 - Do not perform continuous heating for 30 minutes or longer with the product set to 200°C. The safety mechanism may cut the power supply to the halogen lamp.
 - For safety purposes, the high temperature setting is automatically lowered to 160°C if one hour elapses after heating starts.
- The STOP key is always available during measurement. If you suspect any problem or danger, immediately press the STOP key to stop measurement.

1.3. Cautions After Use and Cautions Regarding Storage

CAUTION

Danger of burns caused by high temperature surfaces

- Perform operations after confirming that the various parts of the moisture analyzer have cooled down.
 - In particular, confirm that the area around the glass housing has cooled down before replacing the lamp.

Device Failure

- Do not allow dust or water to enter the inside of the moisture analyzer.
- When cleaning the product, use a cloth dampened with diluted neutral detergent. Do not use organic solvents or chemical wipes. Doing so may cause product failure.
- Make sure to remove the power plug from the power outlet before performing maintenance.
- When transporting the product, use the dedicated packaging box.
- This unit features software-based temperature monitoring with automatic heating shutdown, as well as an independent non-resettable thermal fuse for final overtemperature protection. If the fuse operates, the lamp will no longer heat. Please request repair service.

CAUTION

- Clean the glass housing if it gets dirty, or it may not be able to heat properly. For information on handling, refer to "[15.1. Cleaning the Heater](#)".
- Clean the halogen lamp if it has any fingerprints on it, or its life may be shortened. For information on handling, refer to the separate instruction manual.
- Do not subject the moisture analyzer to impacts or drop it, as doing so may damage the halogen lamp or mass sensor.
- Make sure to remove the power plug from the power outlet if the product will not be used for an extended period of time.

2. Product Overview/Features

- The product adopts an SHS (Super Hybrid Sensor), the mass sensor used in analytical scales, to enable measurement with high accuracy and high reproducibility.
- Because of its high measurement sensitivity, it only requires a small amount of sample, and this contributes to reduced measurement time.
- The product adopts a 400 W halogen lamp as its heater, which allows the tray temperature to reach 200°C within two minutes.
- The product has the following three measurement modes.

Standard mode	This mode automatically measures moisture content by specifying the measurement accuracy.
Timer mode	This mode measures moisture content by heating for a certain period of time.
Custom mode	This mode enables the user to configure detailed measurement conditions.
- The product has the following four heating pattern.

Standard heating	This mode maintains a constant heating temperature.
Slow heating	This mode gradually raises the heating temperature.
Step heating	This mode uses two heating temperatures.
Rapid speed heating	This mode reduces the measurement time by heating at high temperature for a certain period of time after measurement starts.
- 200 sets of optimal measurement conditions for various samples can be configured and recalled when performing measurement.
- More than 100 sets of example measurement conditions for various samples can be recalled when performing measurement.
- The moisture analyzer can store up to 200 measurement results and has a data memory function for the batch output of results.
- The dedicated WinCT-Moisture software has a function for the real-time graphing of changes in moisture content and a function for determining the appropriate heating temperature.
- You can also download the WinCT data communication software from the A&D website for easily importing data to a Windows computer.
- The product is equipped with USB and RS-232C interfaces as standard for easily connecting to a computer or printer.
- The product enables sensitivity adjustment of the mass sensor (use of the dedicated weight is recommended) and adjustment of the heater temperature (requires the dedicated temperature adjustment kit). When performing adjustment, data can be output in response to GLP/GMP/ISO requests.
- The product has a self-inspection function for checking the measurement results of a test sample and checking for electrical circuit and temperature control problems.
- The change in moisture content over time (%/min) during measurement is displayed in real-time. This can be used to help determine the termination value.
- The included sample tray is reusable. Disposable aluminum trays are also included as standard.
- The product has test samples for checking the accuracy of measurement. (Included with the MS-74A/MX-53A as standard.)

- The product has glass fiber sheets for precisely measuring liquid samples in a short time. (Included with the MS-74A/MX-53A as standard.)
- The product has a test mode for measuring the recommended value for the heating temperature (refer to "[7.3. RS TEMP \(Heating Temperature Detection Function\)](#)").

Principle and Intended Use

- The moisture analyzer is based on the principle of thermal mass analysis. It measures properties such as the moisture content and solids in a sample based on changes in mass by heating and drying the sample with a halogen lamp to vaporize the moisture.

3. Content of Package and Names of Parts

- Confirm that all the parts are included.
- Retain the packaging to use for transporting or repairing the product.

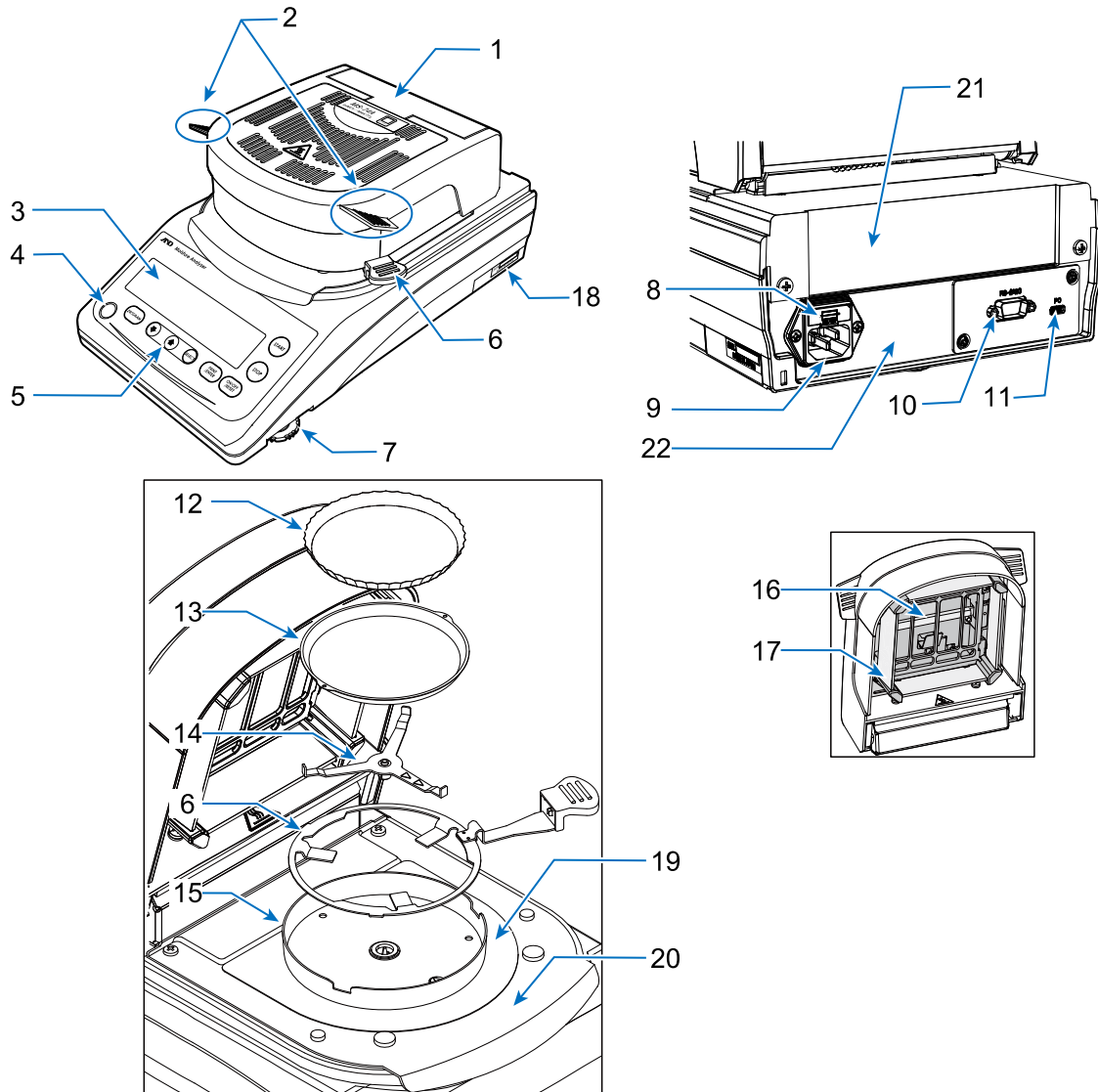

No.	Name	Material
1	Heater cover	PBT, PC, ABS
2	Heater cover handle	PBT
3	Display	
4	Leveler	
5	Keys	
6	Sample tray handle	SUS316, ABS
7	Foot adjuster	Elastomer, SUS

No.	Name	Material
13	Sample tray	Aluminum
14	Tray holder	SUS304, SUS316
15	Breeze break	SUS304 (galvanized)
16	Halogen lamp	
17	Glass housing	Glass, Aluminum die-cast
18	Serial number	
19	Floor panel for insulation	SUS304
20	Floor panel	PBT
21	Main unit upper case	ABS
22	Main unit lower case	Aluminum die-cast (coated)

Accessories

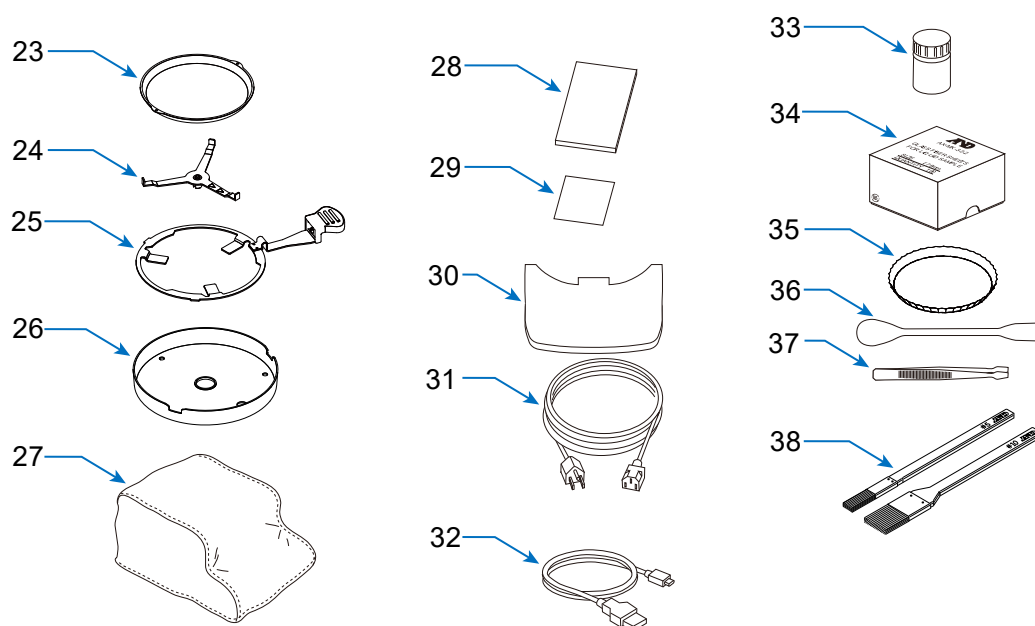

No.	Name	MS-74A	MX-53A	MF-53A	ML-53A	Accessory number
23	Sample tray	× 20	× 20	× 10	× 10	AX-MXA-31
24	Tray holder	Yes	Yes	Yes	Yes	
25	Sample tray handle	× 2	× 2	× 1	× 1	AX-MXA-35
26	Breeze break	Yes	Yes	Yes	Yes	
27	Body cover	Yes	Yes	-	-	AX-MXA-39
28	Quick Start Guide	Yes	Yes	Yes	Yes	
29	Warranty card	Yes	Yes	Yes	Yes	
30	Display protective cover	Yes	Yes	Yes	Yes	AX-MXA-38
31	Power cable	Yes	Yes	Yes	Yes	
32	USB cable (2 m) (Type-A — Type-C)	Yes *2	Yes *2	-	-	AX-KO7919-200
33	Test sample *1	Yes	Yes	-	-	AX-MX-33
34	Glass fiber sheet	× 100	× 100	-	-	AX-MXA-32-2
35	Disposable aluminum tray	× 100	× 100	× 100	× 100	AX-MXA-30
36	Spoon	Yes	Yes	-	-	AX-MX-37
37	Tweezers	Yes	Yes	-	-	AX-MX-36
38	Cleaning brushes (large/small)	Yes	Yes	-	-	AX-CLEANING-SET

Yes: Included; -: Not included

*1 30 g of sodium tartrate dihydrate

*2 UL certified products do not include a USB cable.

3.1. Key Switches and Indicators

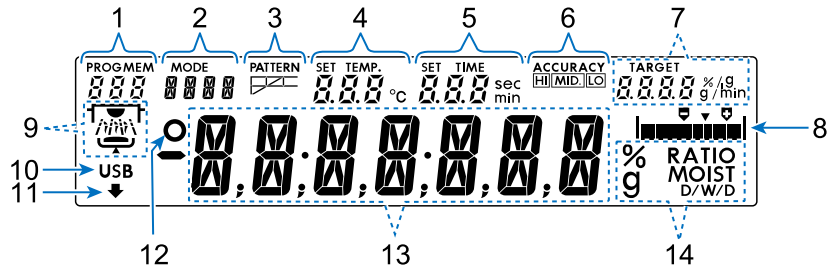

No.	Name
1	Program number Data number (when using data memory)
2	Measurement mode
3	Heating pattern
4	Sample tray temperature indicator (set value/actual value)
5	Measurement time (set value/elapsed time)
6	Measurement accuracy
7	Target value for sample mass Moisture change indicator

No.	Name
8	Level meter
9	Operation indicator
10	USB connection icon
11	Operation icon
12	Stable mass value icon
13	Main display (mass value/moisture content/program ID, etc.)
14	Unit indicator

Example of Displayed Mass

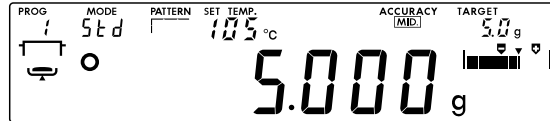

Example of Displayed Operation

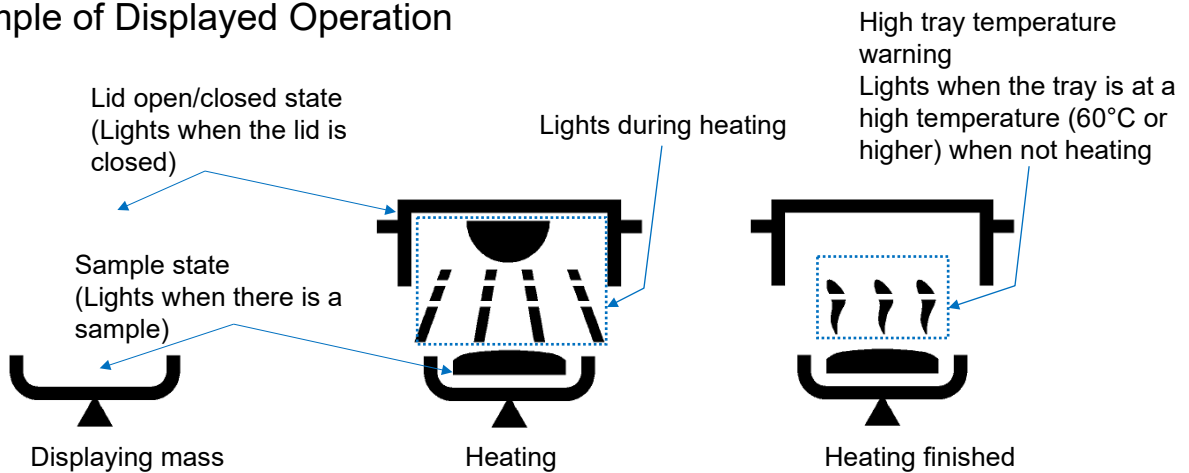













Key Switch Functions and Operations

There are two types of key operations: normal press and long press (press and hold for approx. two seconds).

The regular key operations are normal presses.

Do not long press (press and hold for approx. two seconds) unless necessary.

Key switch		Normal press (press and release immediately)	Long press (for approx. two seconds)
			
	PROGRAM	Enters the mode for selecting the program number.	Displays the function tests and adjustment modes.
	SELECT	Enters the mode for changing the measurement conditions.	Enters the mode for changing the internal settings.
 	 	Changes the set value.	Continuously changes the set value. (Only for some settings)
	ENTER	Confirms the setting or outputs the displayed value.	Used for GLP output and the data memory function.
	START	Starts measurement.	Performs preheating.
	STOP	Stops measurement.	
	RESET	Resets the displayed mass to zero. Turns the display on.	Turns the display off.

4. Requirements for Preparing to Measure (Installation, Initial Configuration, and Measurement)

4.1. Installing the Moisture Analyzer

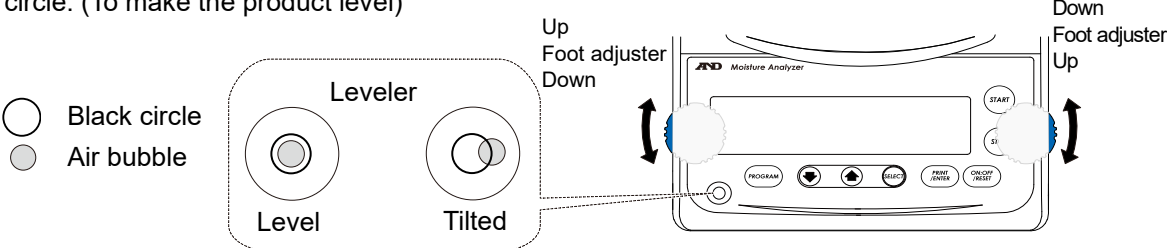
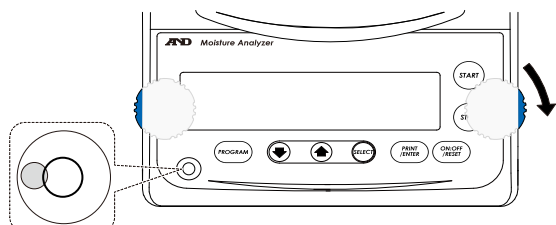
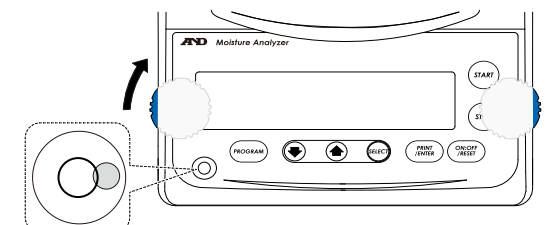
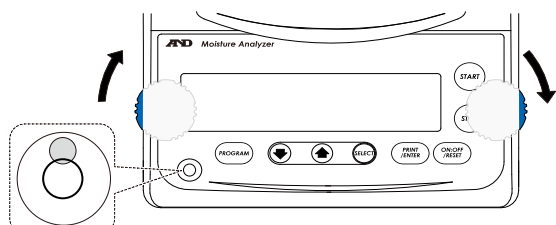
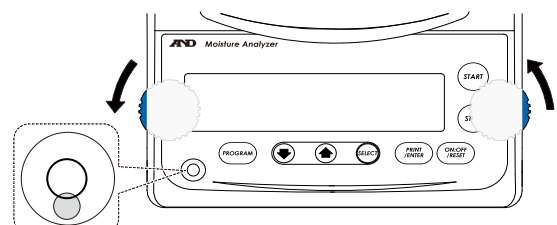
Step	Description
1.	Refer to "1.1. Cautions Regarding Installation " to select the installation location.
2.	<p>Turn the left and right adjustable feet until the air bubble of the leveler is in the center of the black circle. (To make the product level)</p> 
<p>When the air bubble is too far left Turn the foot adjuster on the front right clockwise.</p> 	<p>When the air bubble is too far right Turn the foot adjuster on the front left clockwise.</p> 
<p>When the air bubble is too far backward Turn the two foot adjuster on the front clockwise.</p> 	<p>When the air bubble is too far forward Turn the two foot adjuster on the front counterclockwise.</p> 

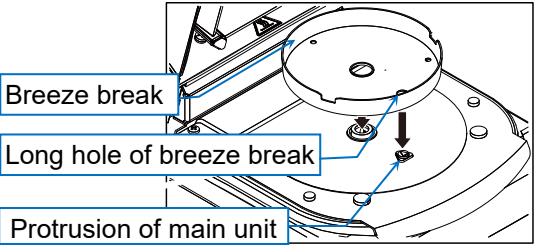
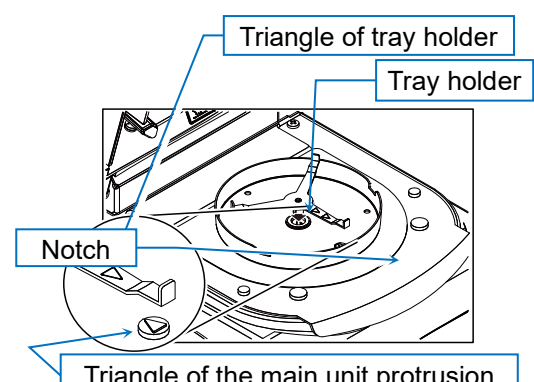
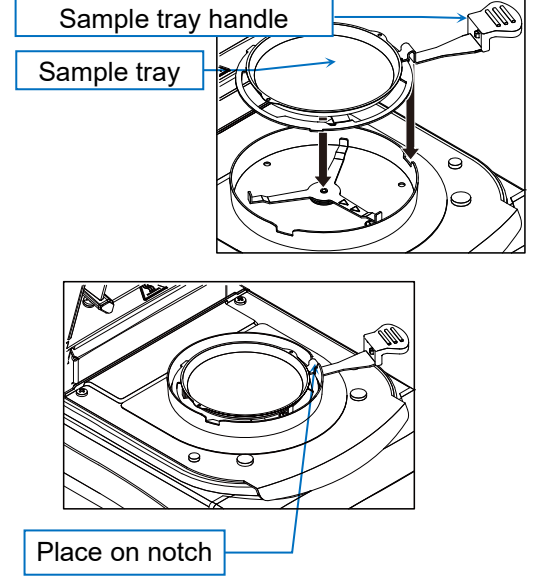
Step	Description	Diagram
3.	Align the long hole of the breeze break with the protrusion of the main unit.	 <p>Breeze break</p> <p>Long hole of breeze break</p> <p>Protrusion of main unit</p>
4.	Align the triangle of the tray holder with the triangle of the main unit.	 <p>Triangle of tray holder</p> <p>Tray holder</p> <p>Notch</p> <p>Triangle of the main unit protrusion</p>
5.	<p>Place the sample tray on the sample tray handle, then align the sample tray handle with the notch of the breeze break.</p> <p>CAUTION</p> <ul style="list-style-type: none"> When using a disposable aluminum tray, make sure to place it on the sample tray. 	 <p>Sample tray handle</p> <p>Sample tray</p> <p>Place on notch</p>

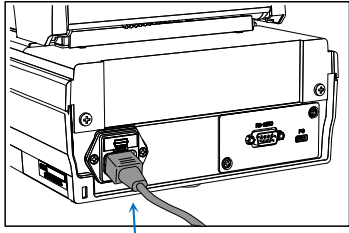
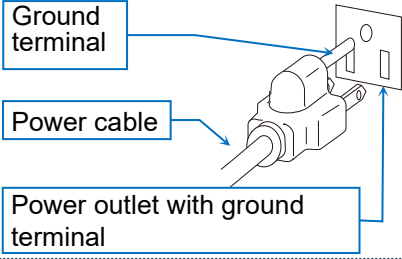
Step	Description	Diagram
	<p>Connect the power cable and ground the moisture analyzer.</p> <p>ADVICE</p> <ul style="list-style-type: none"> When measuring low moisture content less than 1%, it is recommended that you power the product for 30 minutes or more before performing measurement. 	 <p data-bbox="1155 501 1310 533">Power cable</p> <p data-bbox="911 557 1177 593">Grounding Method</p> <p data-bbox="911 598 1294 629">Grounding with the power outlet</p>  <p data-bbox="927 647 1031 703">Ground terminal</p> <p data-bbox="927 748 1082 781">Power cable</p> <p data-bbox="927 837 1225 896">Power outlet with ground terminal</p>

4.2. Requirements for Ensuring Correct Measurement

4.2.1. Handling Samples

- Perform measurement with an appropriate amount of sample. If the amount of sample is small, the accuracy of calculating the moisture content may be adversely affected, which can also affect the reproducibility of the measurement results.
- When measuring samples with an expected moisture content of 1% or less (for example, plastic), the moisture content will be unable to be accurately measured if the amount of sample is small, because the change in mass after heating will also be small because the moisture mass is small. Refer to the table below for the estimated sample mass required for measurement.

Expected moisture content	0.5 to 1%	0.1 to 0.5%	Less than 0.1%
Required sample mass	2 g or more	5 g or more	20 g or more

- When measuring materials such as plastic that are prone to static electricity, we recommend that the AD-1683A is used to eliminate static.

Example	Sample	Expected moisture content	Required sample mass	Heating temperature	Termination value
	PBT	0.08%	20 g	160°C	0.005%/min
	ABS	0.43%	10 g	140°C	0.005%/min

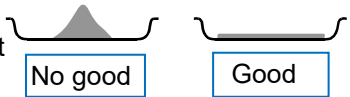
- When repeatedly measuring the same sample, it is recommended that you measure the same amount of sample each time.
- For a sample with large granules, crush the sample before measurement to make it easier for the moisture to vaporize. 
- Spread the sample out evenly on the tray to ensure that it will be evenly heated.
- A heat drying moisture analyzer is suitable for measuring the moisture content of samples where mainly only water will vaporize. Mass changes due to the vaporization or degradation of substances other than water will also be measured as moisture.
- For a liquid sample or sample that forms a film on its surface, the use of a glass fiber sheet (AX-MXA-32-2) is recommended. Refer to "[4.2.4. Using a Glass Fiber Sheet](#)".

4.2.2. Requirements for the Operation Procedure

- Before performing measurement, press the **RESET** key and confirm that the displayed mass stabilizes at zero.
- Before pressing the **START** key to start measurement, confirm that the sample mass is sufficiently stable.
- Configure an appropriate termination value. Use the change in moisture content over time (%/min on the top right of the display) when measurement stops as a guide.
- When repeating measurement, there may be a difference between the first measurement result and the subsequent measurement results, due to the heat distribution of the various parts of the moisture analyzer. Ignore the first measurement result or perform preheating. (Refer to "[4.2.3. How to Use the Preheat Function](#)".)
- If you place a sample on the sample tray while the tray is hot, moisture will vaporize before measurement, and the moisture content will not be measured accurately. Recommended methods for preventing this include alternating between two sample trays when performing consecutive

measurements and waiting about 10 minutes after measurement before performing the next measurement.

- Do not stack sample trays when performing measurement.
- Avoid air conditioner convection and vibrations in the installation location. Otherwise measurement errors may occur or the measured value may not stabilize. The MS-74A in particular is susceptible to such disturbance, as it is high resolution.
- Accurate temperature control may not be possible if there is only a small difference between the sample tray temperature and the surrounding temperature.
(Example) When the sample tray temperature is set to around 30°C to 50°C, the product will be more susceptible to the surrounding temperature.
- Use the icon to check the operation of the halogen lamp. (e.g.) When the sample tray temperature is set to a low temperature, the halogen lamp will light weaker.

The line gradually lights while the halogen lamp is operating.



4.2.3. How to Use the Preheat Function

- The preheat function raises the temperature around the sample tray before performing moisture content measurement.
- The preheat function is effective for increasing the accuracy of moisture content measurement.
- The preheat function is effective when repeatedly measuring the same sample.
(Because the heating conditions vary if the starting temperature differs between the first time and the second and subsequent times, the result of measuring the moisture content may also vary.)
- The preheat temperature is automatically determined according to the set measurement conditions.
- Stop preheating at a time of your choice and start measuring the moisture content.











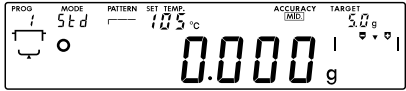

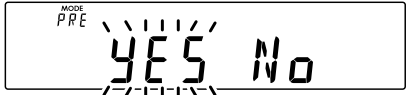
If 30 minutes elapse since preheating started, it will automatically stop.

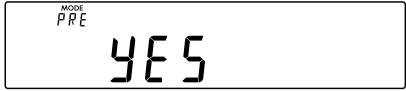
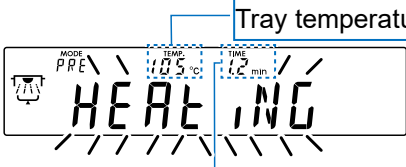
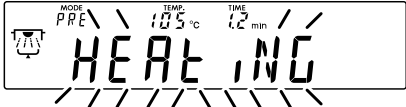
Heating pattern ^{*1} setting	Preheat temperature	Time
Standard heating	Temperature ^{*2} setting	Maximum 30 min
Slow heating	Temperature ^{*2} setting	
Step heating	Temperature step 2 ^{*2} setting	
Rapid heating	Temperature ^{*2} setting	

*1 Refer to "6.4.3. Heating Pattern"

*2 Refer to "6.4.4. Temperature and Time"

Procedure (preparations before moisture content measurement)

Step	Description	Operation
1.	Press and hold the START key.	  Press and hold (for approx. 2 seconds)
2.	With YES selected, press the ENTER key to start preheating.	  
3.	Preheating starts. The current tray temperature and elapsed preheating time are displayed.	
4.	When the target time has elapsed, press the STOP key or open the heater cover to return to the mass display. The displayed value is reset to zero.	   
Remarks	When the preheating time reaches 30 minutes, the heater is automatically turned OFF and TIME UP is displayed. Press the STOP key to return to the mass display. The displayed value is reset to zero.	 30 minutes since preheating started   

4.2.4. Using a Glass Fiber Sheet

- A glass fiber sheet is used for liquid samples, samples that melt when heated, and samples with a surface that is prone to carbonization. Using a glass fiber sheet promotes moisture vaporization and enables faster and more accurate moisture measurement.
- 100 glass fiber sheets are included in a box (AX-MXA-32-2).
A box is included with the MS-74A/MX-53A as standard.
For the MF-53A/ML-53A, glass fiber sheets are available separately.

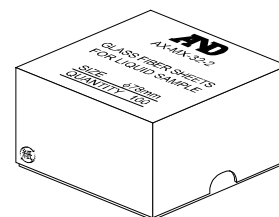



Example use 1: Liquid sample or sample that melts when heated

Soak the glass fiber sheet with the sample to increase the surface area and space required for moisture vaporization to make it easier for the moisture to vaporize. The glass fiber sheet will also help prevent a hard film from forming on the surface of the sample due to heating.

- For liquid samples with high surface tension or high viscosity that do not spread easily, using filter paper (AX-MX-32-1) helps the sample spread more evenly.
- Liquid samples with high moisture content
Examples: Milk, yogurt, liquid glue, hand soap, etc.
- Samples that melt when heated and stick to the tray
Examples: Gum, caramel, etc.
- Samples with high surface tension or high viscosity
Examples: Honey, condensed milk, resin paint, etc.

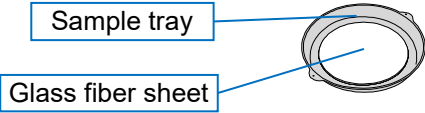
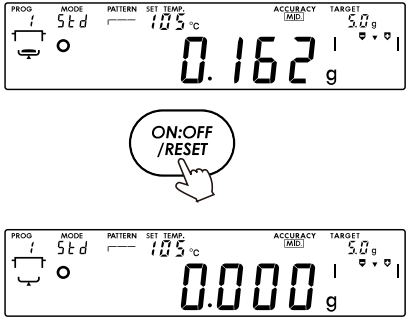
Procedure (preparations before moisture content measurement)

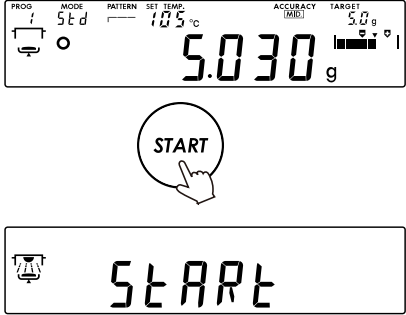
Step	Description	Operation
1.	Spread the glass fiber sheet over the sample tray.	
2.	Press the RESET key to reset the displayed value to zero.	
3.	Soak the glass fiber sheet with the sample. Or, place the sample on the glass fiber sheet.	
4.	Press the START key to start heating.	

Example use 2: Sample with a surface prone to carbonization

Cover the sample with the glass fiber sheet to reduce the sample surface carbonization due to heating.

Preventing sample carbonization enables stable measurement of the moisture content.

- Samples including a lot of sugar, protein, or oil
Example: Honey, soy bean powder, tea leaves, cookies, etc.
- Samples with a black surface that are prone to burning
Example: Coffee, peanuts, etc.

Procedure (preparations before heating)

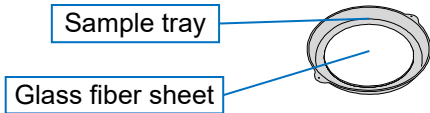
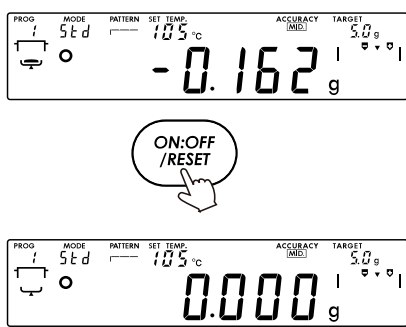
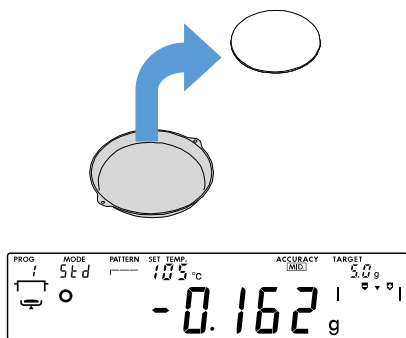
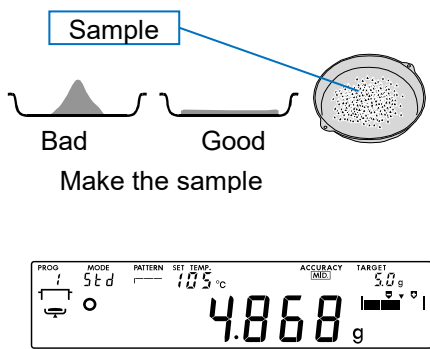
Step	Description	Operation
1.	Spread the glass fiber sheet over the sample tray.	
2.	Press the RESET key to reset the displayed value to zero.	
3.	Remove the glass fiber sheet.	
4.	Place the sample on the sample tray.	

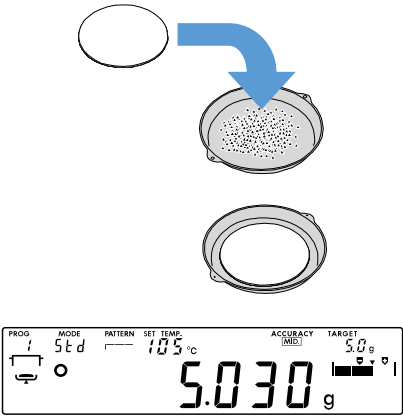
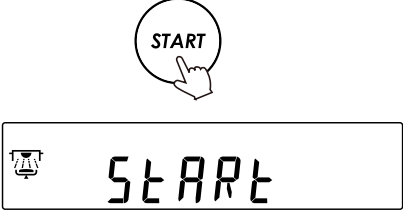
Step	Description	Operation
5.	Cover the top of the sample with the glass fiber sheet removed in step 3.	 <p>The diagram illustrates the process of covering a sample in a crucible with a glass fiber sheet. A blue arrow points from a circular sheet to the top of a crucible containing a granular sample. Below this, the crucible is shown without the sheet. At the bottom, a digital scale display shows the following information: PROG (f), MODE (5t d), PATTERN (—), SET TEMP (105 °C), ACCURACY (0.001 g), and TARGET (5.00 g). The main display shows 5.030 g.</p>
6.	Press the START key to start heating.	 <p>The diagram shows a hand pressing a circular button labeled "START". Below this, a digital scale display shows the word "START" in large letters, indicating that the heating process has begun.</p>





5. Measurement



Measure the moisture content.

To change the measurement conditions, refer to "6.4. Detailed Description of Measurement Conditions".

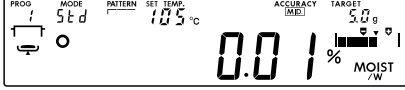
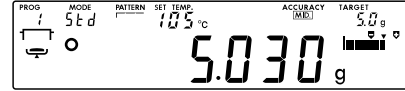
5.1. Procedure for Measuring the Moisture Content

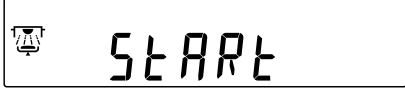
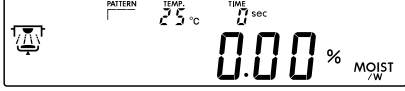
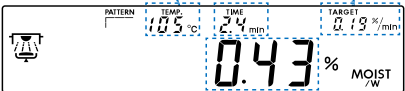
Step	Description	Operation
1.	Turn the power of the main unit ON and display the mass.	
2.	Place the sample tray on the sample tray handle and load them on the tray holder. CAUTION <ul style="list-style-type: none"> Place the sample tray handle in the notch of the breeze break. 	
3.	Close the heater cover.	
4.	When the stable mass value icon lights and the displayed value stabilizes, press the RESET key to reset the displayed mass to zero. (Avoid disturbance such as vibrations during measurement.) If the displayed mass deviates from zero, press the RESET key to reset it to zero.	
5.	Open the heater cover and load an appropriate amount of sample, using the level meter as a guide. CAUTION <ul style="list-style-type: none"> At least 0.1 g of sample is required. Make the sample as flat as possible. 	

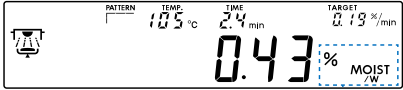
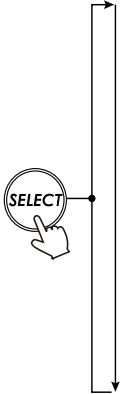
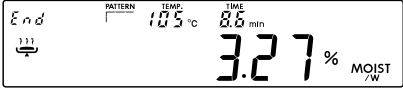
Step	Description	Operation
Remarks	By pressing the  key while the mass is displayed, you can check the unit and minimum displayed value of the moisture content result.	 
Remarks	You can press the ENTER key to output (print) the current mass value. Example computer output (RsCom of WinCT) Standard A&D format (default setting) <code>ST,+0005.030...g<TERM></code> : Space (ASCII 20h) <TERM> : Terminator (CR LF or CR) CR : Carriage return (ASCII 0Dh) LF : Line feed (ASCII 0Ah)	 
6.	Close the heater cover, wait until the mass value stabilizes, then press the START key. The measured value changes according to the vaporization of the moisture in the sample.	    <div style="position: absolute; top: 628px; left: 574px;"> <p>Sample tray temperature</p> </div> <div style="position: absolute; top: 628px; left: 794px;"> <p>Measurement time</p> </div> <div style="position: absolute; top: 652px; left: 784px;"> <p>Change in moisture content</p> </div> <div style="position: absolute; top: 738px; left: 804px;"> <p>Measured value</p> </div>

Step	Description	Operation												
Rem arks	<p>You can press a key during measurement to temporarily select a different measurement basis.</p> <p>CAUTION</p> <ul style="list-style-type: none"> The data output also changes according to the measurement basis. Do not switch the unit while measurement data is being output. 	 <table border="1" data-bbox="1077 313 1423 929"> <thead> <tr> <th>Display</th> <th></th> </tr> </thead> <tbody> <tr> <td>% MOIST /W</td> <td>Moisture content (standard before drying)</td> </tr> <tr> <td>% MOIST /D</td> <td>Moisture content (standard after drying)</td> </tr> <tr> <td>% RATIO D/W</td> <td>Solids</td> </tr> <tr> <td>% RATIO W/D</td> <td>Ratio</td> </tr> <tr> <td>g</td> <td>Grams</td> </tr> </tbody> </table> 	Display		% MOIST /W	Moisture content (standard before drying)	% MOIST /D	Moisture content (standard after drying)	% RATIO D/W	Solids	% RATIO W/D	Ratio	g	Grams
Display														
% MOIST /W	Moisture content (standard before drying)													
% MOIST /D	Moisture content (standard after drying)													
% RATIO D/W	Solids													
% RATIO W/D	Ratio													
g	Grams													
7.	<p>When the termination value is met (either the moisture content going below a certain value or heating continuing for a certain time), a buzzer sounds and measurement stops.</p>													
8.	<p>You can perform the following operations while the result is displayed. The selected text flashes.</p> <p>ENTER key The data is output (printed).</p> <p>  keys Switch the displayed result between percentage and grams.</p> <p>SELECT key, RESET key The product returns to the mass display (step 1).</p> <p>Example computer output (RsCom of WinCT) Standard A&D format</p> <pre>ST,+00003.27_ _ _ %<TERM></pre> <p> _ : Space (ASCII 20h) <TERM> : Terminator (CR LF or CR) CR : Carriage return (ASCII 0Dh) LF : Line feed (ASCII 0Ah) </p>													

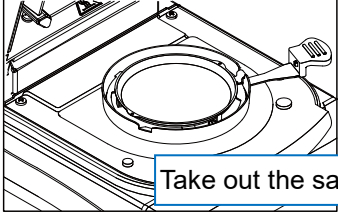
Step	Description	Operation
9.	<p>Open the heater cover, raise the sample tray with the sample tray handle, then take out the sample.</p> <p>ADVICE</p> <ul style="list-style-type: none">• The sample tray can be washed and reused.	 <p>Take out the sample</p>

6. Measurement Conditions

You can save measurement conditions of your choice to program numbers 1 to 200.

By selecting a program number (1 to 200), you can recall the measurement conditions saved to that number. To perform moisture content measurement with the recalled measurement conditions, refer to "[5. Measurement](#)" to start measurement.

To change and save the measurement conditions, refer to "[6.4. Detailed Description of Measurement Conditions](#)".



Example measurement conditions are saved to program numbers 201 and beyond. To use the example measurement conditions, refer to "[6.2.2. How to Use Example Measurement Conditions](#)".

6.1. How to Select a Program Number

Follow the procedure below to select the program number.

By selecting a program number, you can recall the measurement conditions saved to that number.

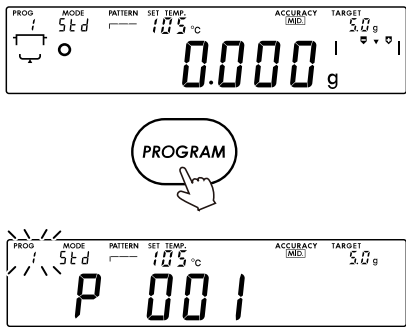
To save new measurement conditions, select the program number to save to, then change and save the measurement conditions (refer to "6.4. Detailed Description of Measurement Conditions").

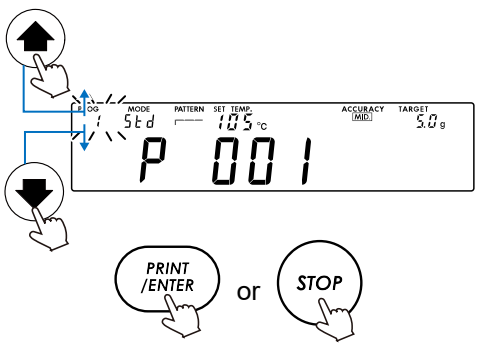
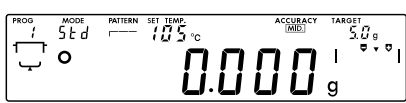
Step	Description	Operation
1.	Press the PROGRAM key with the mass displayed to display the screen for selecting the measurement conditions.	
2.	<p>The program number flashes.</p> <p>An overview of the measurement conditions is displayed.</p> <p>  keys Change the program number.</p> <p>Press and hold to continuously change the value.</p> <p>ENTER key Confirms the flashing program number and returns to the mass display.</p> <p>STOP key Returns to the mass display without changing the program number.</p>	
3.	The product returns to the mass display.	

6.2. Example Measurement Conditions

The product contains example measurement conditions for various types of samples.

When measuring a sample for the first time, you can copy example measurement conditions to a program number from 1 to 200.

You can also change the measurement conditions after copying them.

6.2.1. List of Example Measurement Conditions and Actual Measurement Results

Household Items

Program number	Sample	Program ID	Heating temperature	Termination value ^{*1}	Sample mass	Measurement time	Moisture content			Remarks
							Average value	Reproducibility	CV value	
201	Tobacco	TOBACCO	100°C	0.10%/min	0.9 to 1.1 g	6.5 min	10.58	0.339	3.20	Take apart the sample and measure only the tobacco. There will be a strong odor during heating.
202	Dog food	DOGFOOD	160°C	0.10%/min	0.9 to 1.1 g	9.2 min	8.68	0.059	0.68	Pulverize the sample with a blender before measuring. There will be a strong odor during heating.
203	Toothpaste	TOOTH P	180°C	0.05%/min	0.9 to 1.1 g	8.8 min	51.70	0.046	0.09	Spread the sample over a glass fiber sheet before measuring.
204	Starch glue	STARCHG	200°C	0.05%/min	4.5 to 5.5 g	16.0 min	77.57	0.193	0.25	Spread the sample out evenly before measuring.
205	Laundry starch (liquid)	LSTARCH	200°C	0.05%/min	0.9 to 1.1 g	5.0 min	93.06	0.118	0.13	Spread the sample over a glass fiber sheet before measuring.
206	Wood glue	BOND	200°C	0.05%/min	0.9 to 1.1 g	9.7 min	40.75	0.349	0.86	Spread the sample over a glass fiber sheet before measuring.
207	Hand soap	HNDSOAP	200°C	0.05%/min	0.9 to 1.1 g	7.6 min	91.57	0.077	0.08	Spread the sample over a glass fiber sheet before measuring.

Program number	Sample	Program ID	Heating temperature	Termination value ^{*1}	Sample mass	Measurement time	Moisture content			Remarks
							Average value	Reproducibility	CV value	
208	Lipstick	LIPSTK	100°C	0.01%/min	0.9 to 1.1 g	3.6 min	0.64	0.063	9.86	Spread the sample out directly on the sample tray before measuring.
209	Foundation (liquid)	FNDTN	160°C	0.05%/min	0.9 to 1.1 g	12.2 min	79.69	0.543	0.68	Spread the sample over a glass fiber sheet before measuring.
210	Dried chips (Ezo spruce wood pieces)	DRYCHIP	200°C	0.05%/min	0.9 to 1.1 g	6.6 min	13.55	0.386	2.85	Cut the sample into small strips before measuring.
211	Silica sand	SILSAND	200°C	0.01%/min	9.0 to 11.0 g	4.1 min	0.30	0.022	7.35	
212	Cement (powder)	CEMENT	200°C	0.01%/min	9.0 to 11.0 g	4.1 min	0.68	0.018	2.63	
213	Water-based putty (paste)	PUTTY	160°C	0.05%/min	0.9 to 1.1 g	7.5 min	19.48	0.380	1.95	Use a disposable aluminum tray. Spread the sample out in a thin layer before measuring.
214	Synthetic resin paint (water-based acrylic liquid)	RESINPT	200°C	0.05%/min	0.9 to 1.1 g	16.2 min	54.13	0.254	0.47	Use a disposable aluminum tray. Soak in filter paper before measuring.

*1 For some models, the setting value in the table may be lower than the lower limit value. In that case, the setting value will be set to the lower limit value.

Household Items

Program number	Sample	Program ID	Heating temperature	Termination value ^{*1}	Sample mass	Measurement time	Moisture content			Remarks
							Average value	Reproducibility	CV value	
215	Copier paper	XER PAP	200°C	0.05%/min	0.9 to 1.1 g	3.2 min	6.58	0.128	1.95	Cut the sample into small strips before measuring.
216	Corrugated paper	CARD BD	100°C	0.05%/min	0.9 to 1.1 g	5.2 min	8.20	0.028	0.34	Cut the sample into small strips before measuring. Measure after preheating.
217	Clear file	P FILM	100°C	0.02%/min	0.9 to 1.1 g	2.4 min	0.43	0.044	10.32	Cut the sample into small strips before measuring.

*1 For some models, the setting value in the table may be lower than the lower limit value. In that case, the setting value will be set to the lower limit value.

Food A (grains, beans, seafood, condiments, seasonings, additives)

Program number	Sample	Program ID	Heating temperature	Termination value *1	Sample mass	Measurement time	Moisture content			Remarks
							Average value	Reproducibility	CV value	
218	Corn grits	CORNGTZ	160°C	0.05%/min	4.5 to 5.5 g	14.6 min	13.52	0.017	0.13	
219	Corn starch	CORNST	200°C	0.05%/min	4.5 to 5.5 g	8.0 min	12.86	0.030	0.23	
220	Potato starch	STARCH	200°C	0.05%/min	4.5 to 5.5 g	8.4 min	17.06	0.089	0.52	
221	Buckwheat flour	SOBAFLR	180°C	0.05%/min	4.5 to 5.5 g	12.1 min	13.26	0.081	0.61	
222	Soft flour	CAKEFLR	200°C	0.05%/min	4.5 to 5.5 g	8.1 min	11.71	0.061	0.52	
223	Non-glutinous rice flour	RICEFLR	200°C	0.05%/min	4.5 to 5.5 g	10.5 min	12.53	0.028	0.22	
224	Wheat	ROLOATS	200°C	0.05%/min	4.5 to 5.5 g	14.1 min	12.45	0.093	0.75	
225	Pregelatinized wheat (dry powder)	PREOATS	160°C	0.10%/min	0.9 to 1.1 g	19.7 min	11.80	0.352	2.98	
226	White rice	RICE	200°C	0.10%/min	4.5 to 5.5 g	14.3 min	15.88	0.198	1.25	Pulverize the sample with a blender before measuring.
227	Pre-washed rice	PRERICE	200°C	0.10%/min	0.9 to 1.1 g	9.4 min	16.08	0.214	1.33	
228	Packaged rice (white rice)	PACKRCE	200°C	0.05%/min	1.8 to 2.2 g	19.4 min	64.94	1.235	1.90	
229	Soybean flour	SOY FLR	160°C	0.05%/min	1.8 to 2.2 g	4.6 min	3.89	0.094	2.41	
230	Cashew nuts	CASNUTS	140°C	0.05%/min	4.5 to 5.5 g	7.4 min	1.72	0.065	3.77	Pulverize the sample with a blender before measuring.
231	Butter peanuts	BTPEANT	160°C	0.05%/min	4.5 to 5.5 g	9.1 min	2.85	0.027	0.95	Pulverize the sample with a blender before measuring.
232	Coffee beans (powder)	C BEAN	140°C	0.05%/min	2.7 to 3.3 g	7.9 min	2.75	0.038	1.38	Cover the sample with a glass fiber sheet before measuring.
233	Dried squid	DRD SQD	200°C	0.05%/min	1.8 to 2.2 g	24.0 min	20.42	1.496	7.33	Cut the sample into small strips before measuring.

*1 For some models, the setting value in the table may be lower than the lower limit value. In that case, the setting value will be set to the lower limit value.

Food A (grains, beans, seafood, condiments, seasonings, additives)

Program number	Sample	Program ID	Heating temperature	Termination value *1	Sample mass	Measurement time	Moisture content			Remarks
							Average value	Reproducibility	CV value	
234	Dried squid (precooked)	RHD SQD	160°C	0.05%/min	1.8 to 2.2 g	29.3 min	16.40	0.537	3.27	Cut the sample into small strips before measuring.
235	Dried sardines	DRDSRDN	200°C	0.05%/min	1.8 to 2.2 g	11.0 min	17.02	0.246	1.45	Pulverize the sample with a blender before measuring.
236	Dried whitebait	DRD WBT	200°C	0.05%/min	4.5 to 5.5 g	16.5 min	69.70	0.733	1.05	
237	Coho salmon (raw)	SALMON	200°C	0.05%/min	2.7 to 3.3 g	27.8 min	58.39	1.315	2.25	Use a disposable aluminum tray.
238	Dried bonito fish flakes (light shavings)	DRDBNTO	120°C	0.05%/min	0.9 to 1.1 g	6.1 min	14.30	0.765	5.35	
239	Steamed fish cake	FIS SG	200°C	0.05%/min	1.8 to 2.2 g	21.7 min	77.60	0.300	0.39	Cut the sample into small strips before measuring.
240	Green onion (freeze – dried)	FD SCAL	100°C	0.05%/min	0.9 to 1.1 g	5.4 min	2.41	0.102	4.23	
241	Dehydrated mushrooms	DRDMSHM	140°C	0.05%/min	0.9 to 1.1 g	7 min	7.71	0.203	2.63	Cut the sample into small strips before measuring.
242	Dried sweet potato	DRDSWPT	140°C	0.05%/min	0.9 to 1.1 g	32.2 min	29.44	0.891	3.03	Cut the sample into 3 mm slices and place the slices on a glass fiber sheet before measuring.
243	Japanese radish	RADISH	200°C	0.05%/min	1.8 to 2.2 g	18.9 min	94.66	0.073	0.08	Pulverize the sample with a blender before measuring.
244	Cabbage	CABBAGE	200°C	0.05%/min	0.9 to 1.1 g	16.1 min	92.86	0.089	0.10	Pulverize the sample with a blender before measuring.
245	Pumpkin	PUMPKIN	200°C	0.05%/min	1.8 to 2.2 g	22.6 min	84.98	0.283	0.33	Pulverize the sample with a blender before measuring.
246	Green bell pepper	BLPEPPR	200°C	0.05%/min	1.8 to 2.2 g	18.8 min	93.80	0.094	0.10	Pulverize the sample with a blender before measuring.
247	Dried edible seaweed	SEAWEED	200°C	0.05%/min	0.9 to 1.1 g	7.8 min	4.02	0.195	4.85	Cut the sample into small strips before measuring.
248	Sucrose (powder)	SUGCRYS	140°C	0.01%/min	4.5 to 5.5 g	3.3 min	0.17	0.018	10.87	
249	Brown sugar (powder)	BRN SUG	120°C	0.01%/min	4.5 to 5.5 g	6.0 min	0.69	0.071	10.22	

Program number	Sample	Program ID	Heating temperature	Termination value*1	Sample mass	Measurement time	Moisture content			Remarks
							Average value	Reproducibility	CV value	
250	Salt	SALT	200°C	15 min	9.0 to 11.0 g	15.0 min	0.06	0.003	5.97	
251	Seasoning salt	S SALT	120°C	15 min	9.0 to 11.0 g	15.0 min	0.07	0.010	12.79	
252	Flavor seasoning Umami seasoning	FLVSSN	140°C	0.05%/min	4.5 to 5.5 g	4.4 min	0.88	0.034	3.88	
253	Granulated soup stock	GRANULE	120°C	0.05%/min	4.5 to 5.5 g	13.6 min	2.77	0.136	4.91	
254	Tomato ketchup	KTCHP	160°C	0.05%/min	0.9 to 1.1 g	18.1 min	68.67	0.533	0.78	Spread the sample over filter paper before measuring.
255	Mayonnaise (egg yolk type)	MAYO	180°C	0.05%/min	0.9 to 1.1 g	6.6 min	18.92	0.535	2.83	Spread the sample over a glass fiber sheet before measuring.

*1 For some models, the setting value in the table may be lower than the lower limit value. In that case, the setting value will be set to the lower limit value.

Food A (grains, beans, seafood, condiments, seasonings, additives)

Program number	Sample	Program ID	Heating temperature	Termination value ^{*1}	Sample mass	Measurement time	Moisture content			Remarks
							Average value	Reproducibility	CV value	
256	Pepper (coarsely ground)	PEPPER	200°C	0.05%/min	4.5 to 5.5 g	20.1 min	14.20	0.134	0.94	
257	Curry powder	CURRYPW	180°C	0.05%/min	0.9 to 1.1 g	9 min	9.58	0.163	1.70	
258	Japanese pepper	SANSHO	120°C	0.05%/min	1.8 to 2.2 g	17.6 min	9.45	0.397	4.20	
259	Japanese chili powder	CHILI	120°C	0.05%/min	2.7 to 3.3 g	12.8 min	5.26	0.061	1.16	
260	Japanese seven – spice blend	SC CHIL	120°C	0.05%/min	2.7 to 3.3 g	12.0 min	4.35	0.120	2.76	
261	Grated wasabi (paste)	PAS WAS	180°C	0.05%/min	0.9 to 1.1 g	16.4 min	39.58	0.402	1.02	Use a disposable aluminum tray. Crush the sample with a glass fiber sheet before measuring.
262	Powdered wasabi	POW WAS	140°C	0.05%/min	3.6 to 4.4 g	8.8 min	3.52	0.050	1.42	
263	Mustard (paste with grains)	MUSTARD	200°C	0.05%/min	0.9 to 1.1 g	20.1 min	47.51	0.422	0.89	Use a disposable aluminum tray. Cover the sample with a glass fiber sheet before measuring.
264	Mustard powder	POWMSTD	140°C	0.05%/min	3.6 to 4.4 g	7.5 min	4.09	0.030	0.73	
265	Grated ginger (paste)	GINGER	200°C	0.05%/min	0.9 to 1.1 g	13.8 min	87.01	0.366	0.42	Use a disposable aluminum tray. Cover the sample with a glass fiber sheet before measuring.
266	Citric acid	CITRIC	100°C	0.10%/min	4.5 to 5.5 g	7.2 min	4.54	0.210	4.63	
267	Dextrose anhydrous	ANHYGLU	140°C	0.05%/min	4.5 to 5.5 g	1.2 min	0.21	0.022	10.48	

*1 For some models, the setting value in the table may be lower than the lower limit value. In that case, the setting value will be set to the lower limit value.

Food B (processed foods, dairy products, confectionery, other)

Program number	Sample	Program ID	Heating temperature	Termination value ^{*1}	Sample mass	Measurement time	Moisture content			Remarks
							Average value	Reproducibility	CV value	
268	White bread	BREAD	160°C	0.05%/min	0.9 to 1.1g	10.7 min	41.97	0.611	1.46	Cut the sample into small strips before measuring.
269	Breadcrumbs	BRDCRMB	200°C	0.05%/min	0.9 to 1.1g	6.9 min	11.52	0.087	0.76	
270	Dehydrated soup	DRYSOUP	120°C	0.05%/min	0.9 to 1.1g	8.4 min	3.29	0.048	1.46	Corn cream soup. Remove the kernels before measuring.

*1 For some models, the setting value in the table may be lower than the lower limit value. In that case, the setting value will be set to the lower limit value.

Food B (processed foods, dairy products, confectionery, other)

Program number	Sample	Program ID	Heating temperature	Termination value ^{*1}	Sample mass	Measurement time	Moisture content			Remarks
							Average value	Reproducibility	CV value	
271	Instant miso soup (paste)	BP SOUP	200°C	0.05%/min	0.9 to 1.1g	18.3 min	65.37	0.364	0.56	Use a disposable aluminum tray. Place on filter paper before measuring.
272	Instant Chinese noodles	INSTNDL	180°C	0.05%/min	1.8 to 2.2g	8.2 min	1.82	0.051	2.81	Crush the sample into small pieces before measuring.
273	Croutons	SIPPET	200°C	0.05%/min	1.8 to 2.2g	8.5 min	8.02	0.158	1.97	Crush the sample into small pieces before measuring.
274	Breakfast cereal (brown rice)	CEREAL	180°C	0.05%/min	1.8 to 2.2g	7.2 min	2.33	0.050	2.14	Crush the sample into small pieces before measuring.
275	Dehydrated spaghetti	PASTA	200°C	0.05%/min	1.8 to 2.2g	31.3 min	11.50	0.203	1.77	Crush the sample into small pieces before measuring.
276	Dried udon noodles	DRYUDON	200°C	0.05%/min	4.5 to 5.5g	18 min	14.04	0.445	3.17	Cut the sample into 1 cm slices before measuring.
277	Boiled udon noodles	UDON	200°C	0.05%/min	2.7 to 3.3g	23.3 min	67.37	0.257	0.38	
278	Dried bean vermicelli	B VERM	200°C	0.05%/min	1.8 to 2.2g	22.3 min	11.80	0.132	1.12	Cut the sample into 1 cm slices before measuring.

Program number	Sample	Program ID	Heating temperature	Termination value*1	Sample mass	Measurement time	Moisture content			Remarks
							Average value	Reproducibility	CV value	
279	Dried wakame seaweed	SEAWEED	200°C	0.05%/min	0.9to 1.1g	11.51 min	8.90	0.250	2.81	Pulverize the sample with a blender before measuring.
280	Wood ear mushroom (sliced)	WOODEAR	180°C	0.05%/min	1.8to 2.2g	25.7 min	14.39	0.205	1.42	Pulverize the sample with a blender before measuring.
281	Beef jerky	BFJERKY	180°C	0.05%/min	1.8to 2.2g	29.5 min	20.10	0.974	4.85	Cut the sample into small strips before measuring.
282	Rice cracker	R CRACK	200°C	0.05%/min	4.5to 5.5g	10.0 min	5.64	0.128	2.27	Crush the sample into small pieces in a mortar before measuring.
283	Cookie	COOKIE	160°C	0.05%/min	4.5to 5.5g	6.3 min	2.11	0.066	3.13	Lightly crush the sample before measuring.
284	Langue de chat	LNGCHAT	160°C	0.05%/min	1.8to 2.2g	6.1 min	2.45	0.069	2.82	Lightly crush the sample before measuring.
285	Pie crust (thawed)	PIE DGH	200°C	0.05%/min	1.8to 2.2g	12.5 min	30.65	0.209	0.68	Cut the sample into small slices with scissors before measuring.
286	Banana chips (sliced)	Banana chips	160°C	0.05%/min	1.8to 2.2g	7.9 min	1.98	0.259	13.03	Crush the sample into small pieces in a mortar before measuring.
287	Potato chips	P CHIPS	160°C	0.05%/min	4.5to 5.5g	8.3 min	2.19	0.060	2.74	Lightly crush the sample before measuring.
288	Snack (shrimp flavor)	S SNACK	160°C	0.05%/min	0.9to 1.1g	4.5 min	2.55	0.146	5.73	Lightly crush the sample before measuring.
289	Snack (fried noodles)	N SNACK	160°C	0.05%/min	4.5to 5.5g	8.4 min	1.54	0.040	2.60	
290	Gummy candy	GUMMY	120°C	0.05%/min	2.7 to 3.3g	29.7 min	3.40	0.235	6.92	Use a disposable aluminum tray.
291	Jam (strawberry)	JAM	180°C	0.05%/min	0.9to 1.1g	15.7 min	59.84	0.780	1.30	Spread the sample over filter paper before measuring.
292	Honey Heated to 120 °C	HONEY 1	120°C	0.05%/min	0.9to 1.1g	19.5 min	17.05	0.338	1.98	Spread the sample over filter paper before measuring.
293	Honey Heated to 140 °C	HONEY 2	140°C	0.05%/min	0.9to 1.1g	14.1 min	18.61	0.326	1.75	Spread the sample over filter paper before measuring.

*1 For some models, the setting value in the table may be lower than the lower limit value. In that case, the setting value will be set to the lower limit value.

Food B (processed foods, dairy products, confectionery, other)

Program number	Sample	Program ID	Heating temperature	Termination value ^{*1}	Sample mass	Measurement time	Moisture content			Remarks
							Average value	Reproducibility	CV value	
294	Honey Heated to 160 °C	HONEY 3	160°C	0.05%/min	0.9 to 1.1g	24.6 min	21.78	1.578	7.25	Spread the sample over filter paper before measuring.
295	Red bean paste (coarse)	ANKO	180°C	0.05%/min	0.9 to 1.1g	11.6 min	33.56	0.194	0.58	Use a disposable aluminum tray. Cover the sample with a glass fiber sheet before measuring.
296	Milk	MILK	160°C	0.05%/min	0.9 to 1.1g	7.2 min	88.49	0.335	0.38	Use a disposable aluminum tray. Cover the sample with a glass fiber sheet before measuring.
297	Butter (solid, salted)	BUTTER	200°C	0.05%/min	0.9 to 1.1g	3.13 min	15.00	0.542	3.61	Spread the sample over a glass fiber sheet before measuring.
298	Grated cheese	GCHEESE	200°C	0.05%/min	0.9 to 1.1g	10 min	13.75	0.110	0.80	
299	Powdered skim milk	S MILK	140°C	0.10%/min	1.8 to 2.2g	16.7 min	6.49	0.255	3.93	
300	Infant formula	MP MILK	140°C	0.05%/min	1.8 to 2.2g	5.7 min	3.07	0.145	0.80	
301	Yogurt (hard type)	YOGURT	200°C	0.05%/min	0.9 to 1.1g	13 min	85.20	0.334	0.39	Spread the sample over a glass fiber sheet before measuring.
302	Coffee creamer	MSUBST	180°C	0.05%/min	0.9 to 1.1g	6.9 min	88.11	0.294	0.33	Use a disposable aluminum tray. Cover the sample with a glass fiber sheet before measuring.
303	Sweetened condensed milk	C MILK	160°C	0.05%/min	0.9 to 1.1g	16 min	28.74	0.311	1.08	Use a disposable aluminum tray. Place on filter paper before measuring.
304	Fat spread	FATSPRD	200°C	0.05%/min	0.9 to 1.1g	3.25 min	31.26	0.486	1.55	Spread the sample over a glass fiber sheet before measuring.
305	Soy milk	SOYMILK	140°C	0.05%/min	0.9 to 1.1g	7.5 min	96.65	0.648	0.67	Use a disposable aluminum tray. Soak in filter paper before measuring.
306	Tea leaves (Green tea. Kukicha)	GRN TEA	120°C	0.05%/min	4.5 to 5.5g	10.4 min	2.03	0.035	1.72	Pulverize the sample with a blender before measuring.

Program number	Sample	Program ID	Heating temperature	Termination value*1	Sample mass	Measurement time	Moisture content			Remarks
							Average value	Reproducibility	CV value	
307	Instant coffee (powder)	COFFEE	120°C	0.05%/min	3.6 to 4.4g	11.2 min	4.20	0.182	4.33	Cover the sample with a glass fiber sheet before measuring.
308	Orange juice (from concentrate)	O JUICE	160°C	0.05%/min	0.9 to 1.1g	10.3 min	89.68	0.380	0.42	Use a disposable aluminum tray. Cover the sample with a glass fiber sheet before measuring.
309	Sports drink (powder)	P BEVER	120°C	0.01%/min	4.5 to 5.5g	4.3 min	0.23	0.024	10.53	
310	Sports drink (jelly)	G BEVER	180°C	0.05%/min	0.9 to 1.1g	17.1 min	75.49	0.431	0.57	Use a disposable aluminum tray. Place on filter paper before measuring.
311	Agar powder	AGARPOW	200°C	0.05%/min	4.5 to 5.5g	7.5 min	15.95	0.066	0.41	
312	Gelatin (powder)	GELATIN	200°C	0.05%/min	4.5 to 5.5g	9.4 min	12.46	0.030	0.24	

*1 For some models, the setting value in the table may be lower than the lower limit value. In that case, the setting value will be set to the lower limit value.

Chemicals

Program number	Sample	Program ID	Heating temperature	Termination value*1	Sample mass	Measurement time	Moisture content			Remarks
							Average value	Reproducibility	CV value	
313	Skincare cream	SKINCRM	180°C	0.05%/min	0.9to 1.1g	19.8 min	75.08	0.514	0.68	Place the squashed sample between a glass fiber sheet folded into two before measuring.
314	Sodium tartrate dihydrate	TARTNA	160°C	0.05%/min	4.5to 5.5g	8 min	15.71	0.007	0.04	
315	Cellulose	CELLOSE	200°C	0.05%/min	4.5to 5.5g	4.3 min	4.00	0.073	1.83	
316	Calcium stearate	STECA	180°C	0.10%/min	4.5to 5.5g	7.6 min	2.90	0.030	1.03	There will be a strong odor during heating.
317	Zinc oxide	ZN OX	200°C	0.01%/min	4.5to 5.5g	4.8 min	0.14	0.010	7.04	
318	Aluminum oxide	ALUM OX	200°C	0.01%/min	4.5to 5.5g	6.5 min	0.25	0.006	2.38	
319	Magnesium oxide	MG OX	200°C	0.01%/min	1.8to 2.2g	3 min	0.44	0.020	4.40	
320	Talc	TALC	160°C	0.01%/min	4.5to 5.5g	5.1 min	0.18	0.011	6.15	Measure after preheating.
321	Calcium carbonate	CACO3	200°C	0.01%/min	4.5to 5.5g	5.8 min	0.12	0.004	3.42	

*1 For some models, the setting value in the table may be lower than the lower limit value. In that case, the setting value will be set to the lower limit value.

Industrial Products

Program number	Sample	Program ID	Heating temperature	Termination value*1	Sample mass	Measurement time	Moisture content			Remarks
							Average value	Reproducibility	CV value	
322	Charcoal (powder)	CHARCL	200°C	0.05%/min	0.9to 1.1g	2.3 min	6.81	0.777	11.40	Lightly crush the sample before measuring.
323	Activated carbon granular, for deodorizers)	ACTCHAR	120°C	0.05%/min	4.5to 5.5g	2.4 min	2.65	0.070	2.64	Cover the sample with a glass fiber sheet before measuring.
324	Red soil aggregate (small grains)	REDSOIL	200°C	0.05%/min	2.7to 3.3g	10.1 min	27.45	0.475	1.73	
325	Silica gel (particulate)	SIL PRT	200°C	0.05%/min	4.5to 5.5g	6.4 min	19.40	0.032	0.16	Leave the sample for one day at 23°C room temperature before measuring.
326	Print toner (powder, black)	P TONER	100°C	0.10%/min	4.5to 5.5g	1.6 min	0.298	0.013	4.36	

*1 For some models, the setting value in the table may be lower than the lower limit value. In that case, the setting value will be set to the lower limit value.

Plastics

Program number	Sample	Program ID	Heating temperature	Termination value ^{*1}	Sample mass	Measurement time	Moisture content			Remarks
							Average value	Reproducibility	CV value	
327	PC pellets (Poly carbonate)	PC	130°C	0.001%/min	24.0 to 25.0g	15 min	0.093	0.002	2.15	When measuring a 0.5 g sample heated to 230°C with the Karl Fischer method three times and taking the average: 0.077% moisture content and 0.0021% reproducibility with a measurement time of 30 minutes
328	POM pellets (Polyoxy methylene)	POM	130°C	0.001%/min	24.0 to 25.0g	15.6 min	0.101	0.0009	0.89	When measuring a 2 g sample heated to 200°C with the Karl Fischer method three times and taking the average: 0.087% moisture content and 0.0022% reproducibility with a measurement time of 30 minutes
329	PET pellets (polyethylene terephthalate)	PET	160°C	0.001%/min	24.0 to 25.0g	9.0 min	0.045	0.0008	1.78	When measuring a 3 g sample heated to 230°C with the Karl Fischer method three times and taking the average: 0.027% moisture content and 0.0025% reproducibility with a measurement time of 30 minutes
330	ABS pellets (Acrylonitrile Butadiene Styrene copolymer)	ABS	130°C	0.001%/min	24.0 to 25.0g	21.0 min	0.203	0.0027	1.33	When measuring a 0.1 g sample heated to 200°C with the Karl Fischer method three times and taking the average: 0.192% moisture content and 0.0097% reproducibility with a measurement time of 30 minutes

*1 For some models, the setting value in the table may be lower than the lower limit value. In that case, the setting value will be set to the lower limit value.

Electrical Components

Program number	Sample	Program ID	Heating temperature	Termination value ^{*1}	Sample mass	Measurement time	Moisture content			Remarks
							Average value	Reproducibility	CV value	
331	CPU (100 pin plastic QFP, 14 × 20 mm)	CPU	120°C	0.05%/min	9.0 to 11.0g	1.7 min	0.064	0.0055	8.59	Leave the sample for two days in a thermostatic tank at 80% RH and 30°C room temperature before measuring.

^{*1} For some models, the setting value in the table may be lower than the lower limit value. In that case, the setting value will be set to the lower limit value.

Rubber

Program number	Sample	Program ID	Heating temperature	Termination value ^{*1}	Sample mass	Measurement time	Moisture content			Remarks
							Average value	Reproducibility	CV value	
332	Ground tire	TIRE	200°C	0.10%/min	4.5 to 5.5 g	4.3 min	22.30	0.080	0.36	Pulverize the sample before measuring.







^{*1} For some models, the setting value in the table may be lower than the lower limit value. In that case, the setting value will be set to the lower limit value.

Sewage

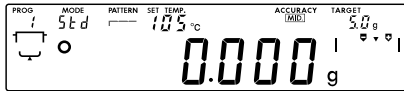
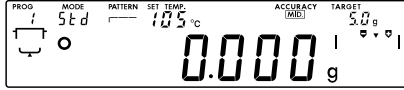
Program number	Sample	Program ID	Heating temperature	Termination value ^{*1}	Sample mass	Measurement time	Moisture content			Remarks
							Average value	Reproducibility	CV value	
333	Sewage (human waste, liquid)	SEWAGE	140°C	0.10%/min	0.9 to 1.1 g	5.7 min	99.14	0.233	0.24	Use a glass fiber sheet. There will be a strong odor during heating.
334	Sludge cake (human waste, dehydrated, paste)	SEWAGEP	200°C	0.10%/min	4.5 to 5.5 g	16.3 min	86.64	0.560	0.65	There will be a strong odor during heating.

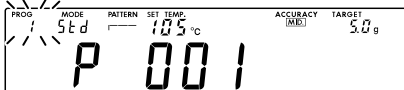
^{*1} For some models, the setting value in the table may be lower than the lower limit value. In that case, the setting value will be set to the lower limit value.

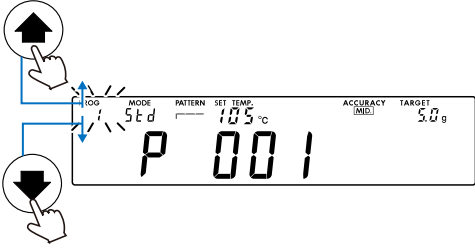
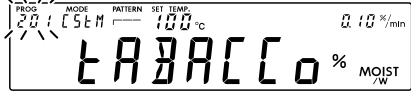
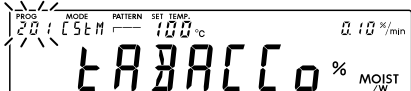

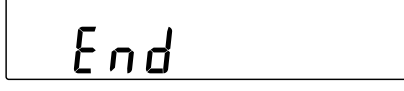
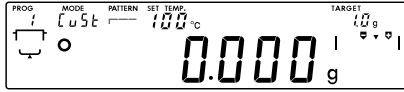

6.2.2. How to Use Example Measurement Conditions

Step	Description	Operation
1.	Refer to "6.1. How to Select a Program Number" to select the program number to change the measurement conditions of.	
2.	Press the PROGRAM key with the mass displayed to display the screen for selecting the measurement conditions.	  
3.	<p>The program number flashes.</p> <p>An overview of the measurement conditions is displayed.</p> <p>Press the   keys to change the value of the program number.</p> <p>The example measurement conditions are in program number 201 and beyond.</p> <p>Select the example measurement conditions to use.</p> <p>Press and hold to continuously change the value.</p>	 
4.	Press the ENTER key.	  
5.	<p>The product returns to the mass display.</p> <p>The example measurement conditions selected in step 4 are copied to the program number selected in step 1.</p> <p>You can change the measurement conditions after copying them.</p> <p>(Refer to "6.4. Detailed Description of Measurement Conditions".)</p>	

6.3. Overview of Measurement Conditions

6.3.1. List of Measurement Conditions

The following list indicates the items that can be configured in the measurement conditions. For details on each item, refer to "6.4. Detailed Description of Measurement Conditions".

Measurement Conditions	Program number	(1 to 200)		
	Program ID	(maximum 7 characters)		
	Measurement mode	Standard mode		
		Timer mode		
		Custom mode		
	Heating pattern	Standard heating		
		Slow heating		
		Step heating		
		Rapid heating		
	Heating temperature	Temperature ^{*1}	(30 to 200°C)	
		Temperature step 1 ^{*1}	(30 to 200°C)	
		Temperature step 2 ^{*1}	(30 to 200°C)	
	Heating time	Time step 1 ^{*1}	(1 to 480 min)	
		Overall measurement time ^{*1}	(1 to 480 min)	
	Measurement accuracy ^{*1}	High		
		Standard		
		Low		
	Termination value ^{*1}	(0.001 to 2%/min) ^{*2}		
	Sample mass	Maximum mass value	(0 to 50 or 70 g) ^{*2}	
		Minimum mass value	(0 to 50 or 70 g) ^{*2}	
Measurement basis	Moisture content (standard before drying)			
	Moisture content (standard after drying)			
	Solids			
	Ratio			
	Grams			
Minimum displayed	Percentage	(0.001 to 1%) ^{*2}		
	Grams	(0.0001 to 0.1 g) ^{*2}		
Comparator	Upper limit value	(0.0 to 999.9%)		
	Lower limit value	(0.0 to 999.9%)		
Correction of measurement results	Offset (added to moisture content)	(-9.999% to 9.999%) ^{*2}		

*1 May not be able to be set, depending on the other settings.

*2 The range of available values depends on the model.

6.3.2. Available Measurement Conditions

The available measurement conditions depend on the selected measurement mode.

Measurement condition	Measurement mode		
	Standard measurement mode	Timer mode	Custom mode
Program ID	Yes		
Heating pattern	Yes		
Temperature	Yes		
Time	(The available items differ for each measurement mode and heating pattern. Refer to "6.4.4. Temperature and Time")		
Measurement accuracy	Yes	No	No
Termination value	No	No	Yes
Sample mass	No	Yes	Yes
Measurement basis	Yes		
Minimum displayed (%)	No	Yes	Yes
Minimum displayed (g)	No	Yes	Yes
Comparator (maximum, minimum)	Available when the function is enabled in the internal settings. Refer to "8. Internal Settings"		
Correction of measurement results			

6.3.3. Default Setting

The default measurement conditions are set as follows.













Measurement condition	MS-74A	MX-53A	MF-53A	ML-53A
Program ID	P *** (where *** is the program number)			
Measurement mode	Standard measurement mode			
Heating pattern	Standard heating			
Temperature	105°C			
Time				
Measurement accuracy	MID.			
Termination value	0.02%/min	0.05%/min	0.10%/min	0.20%/min
Sample mass	5 g			
Measurement basis	Moisture content (standard before drying)			
Minimum displayed (%)	0.001%	0.01%	0.05%	0.1%
Minimum displayed (g)	0.001 g	0.001 g	0.002 g	0.005 g
Comparator (maximum, minimum)	Do not compare			
Correction of measurement results	Do not correct			

6.4. Detailed Description of Measurement Conditions





This section provides a detailed description of the measurement conditions and the method for configuring the settings.

The following keys are used to configure the settings.

Operation Keys

Key switch		Function and operation
		Enters the mode for changing the measurement conditions. Moves to the next selection.
 	 	Changes the value of the selected measurement condition.
		Saves the values configured for the measurement conditions.
 	 	Exits without saving the values configured for the measurement conditions.

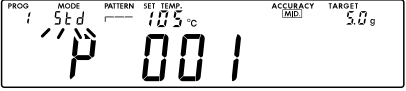

6.4.1. How to Select Measurement Conditions

Step	Description	Example Display
1.	Switch to the mass display.	
2.	Press the  key.	
3.	The measurement mode flashes, and the product switches to the screen for changing the measurement conditions.	
4.	The selected item changes each time the  key is pressed. The flashing item is the currently selected item.	

6.4.2. Measurement Modes

Mode name	Description of operation
Standard mode	The standard mode for configuring the main parameters only. The sample mass, termination value, minimum displayed (%), and minimum displayed (g) are automatically set according to the measurement accuracy. (Refer to "6.4.5. Measurement Accuracy".)
Timer mode	The mode for configuring the heating time. (1 to 480 min)
Custom mode	The mode for setting the termination value (change in moisture content) to an arbitrary value.



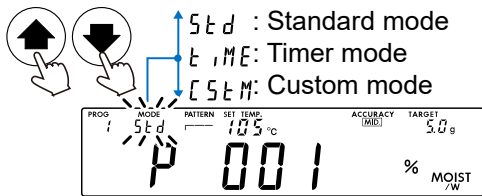

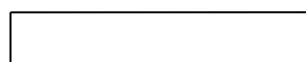
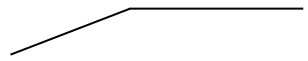
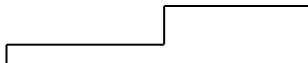
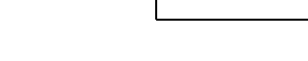

Changing the Measurement Conditions

Step	Description	Example Display
1.	<p>Refer to "6.4.1. How to Select Measurement Conditions" to switch the operation for changing the measurement mode.</p> <p>The current measurement mode flashes.</p> <p>  keys Change the measurement mode.</p>	 <p>Std : Standard mode t, ME: Timer mode C S T M: Custom mode</p> <p>PROG: 1 MODE: Std PATTERN: SET TEMP: 105 °C ACCURACY (MM): TARGET: 5.0 g P 001 % MOIST / W</p>

6.4.3. Heating Pattern

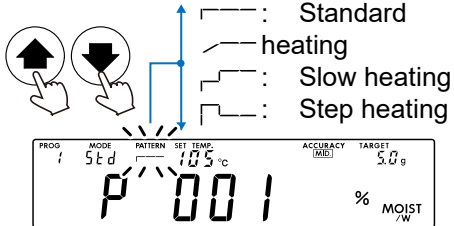
Heating pattern name	Temperature change	Description
Standard heating		Maintains the set temperature.
Slow heating		Gradually raises the temperature over time until the set temperature is reached. Then maintains the set temperature.
Step heating		Enables you to set two temperatures. Set the two temperatures and the time to maintain the first temperature.
Rapid heating		Performs heating for approx. three minutes at 200°C. Then maintains the set temperature.

Changing the Heating Pattern

Step	Description	Example Display
1.	<p>Refer to "6.4.1. How to Select Measurement Conditions" to select the operation for changing the heating pattern.</p> <p>The current heating pattern flashes.</p> <p>  keys Change the heating pattern.</p>	 <p>   : Standard heating  : Slow heating  : Step heating </p> <p> PROG: 1 MODE: Std PATTERN: P SET TEMP: 175 °C ACCURACY (WGT): 5.0 g P 001 % MOIST W </p>

6.4.4. Temperature and Time

Arbitrary values can be set for the heating temperature and time.

Temperature: 30 to 200°C (in 1°C increments)

Time: 1 to 480 min (1 min increments)

The available temperature and time values differ according to the measurement mode and heating pattern.

The table below indicates the available temperatures and times for each condition.

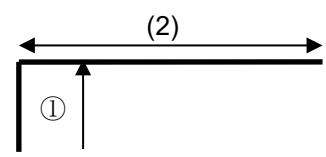
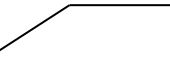
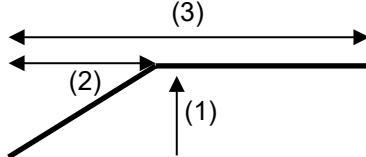
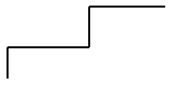
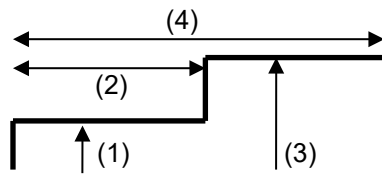
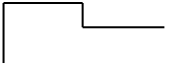
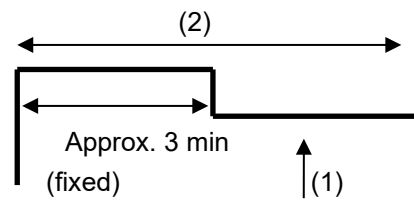
Heating pattern	Available temperature and time
<p>Standard heating</p> 	<p>(1) Temperature (2) Overall measurement time*¹</p> 
<p>Slow heating</p> 	<p>(1) Temperature (2) Time step 1 (3) Overall measurement time*¹</p> 
<p>Step heating</p> 	<p>(1) Temperature step 1 (2) Time step 1 (3) Temperature step 2 (4) Overall measurement time*¹</p> 
<p>Rapid heating</p> 	<p>(1) Temperature (2) Overall measurement time*¹</p> <p>Approx. 3 min (fixed)</p> 

*¹ The value set for the overall measurement time can only be configured when the measurement mode is set to the timer mode.

Changing the Temperature

Step	Description	Example Display												
1.	<p>Refer to "6.4.1. How to Select Measurement Conditions" to select the operation for changing the temperature.</p> <ul style="list-style-type: none"> The temperature that is currently set flashes. The information on the main display differs according to the value set for the heating pattern. 	<p>+1°C (200°C maximum) -1°C (30°C minimum)</p> <p>Example program ID</p> <p>Example step 1</p> <p>Example step 2</p>												
	<table border="1"> <thead> <tr> <th>Heating pattern</th> <th>Selected temperature</th> <th>Main display</th> </tr> </thead> <tbody> <tr> <td>Standard/slow/rapid</td> <td>Temperature</td> <td>Program ID</td> </tr> <tr> <td>Step</td> <td>Temperature step 1</td> <td>SEEP 1</td> </tr> <tr> <td>Step</td> <td>Temperature step 2</td> <td>SEEP 2</td> </tr> </tbody> </table> <p> keys Change the set temperature value. </p>	Heating pattern	Selected temperature	Main display	Standard/slow/rapid	Temperature	Program ID	Step	Temperature step 1	SEEP 1	Step	Temperature step 2	SEEP 2	
Heating pattern	Selected temperature	Main display												
Standard/slow/rapid	Temperature	Program ID												
Step	Temperature step 1	SEEP 1												
Step	Temperature step 2	SEEP 2												

Changing the Time

Step	Description	Example Display									
1.	<p>Refer to "6.4.1. How to Select Measurement Conditions" to select the operation for changing the time.</p> <p>The time that is currently set flashes.</p> <p>The information displayed for the measurement value differs according to the measurement mode and heating pattern.</p>	<p>+1 min -1 min</p> <p>Example program ID</p> <p>Example display</p>									
	<table border="1"> <thead> <tr> <th>Condition</th> <th>Selected time</th> <th>Part displayed for measured value</th> </tr> </thead> <tbody> <tr> <td>Heating pattern: Slow/step</td> <td>Time step 1</td> <td>SEEP 1</td> </tr> <tr> <td>Measurement mode: Timer mode</td> <td>Overall measurement time</td> <td>total</td> </tr> </tbody> </table> <p> keys Change the set time value. </p>	Condition	Selected time	Part displayed for measured value	Heating pattern: Slow/step	Time step 1	SEEP 1	Measurement mode: Timer mode	Overall measurement time	total	
Condition	Selected time	Part displayed for measured value									
Heating pattern: Slow/step	Time step 1	SEEP 1									
Measurement mode: Timer mode	Overall measurement time	total									

6.4.5. Measurement Accuracy

This can only be selected with the standard measurement mode.

One of three levels (HI, MID, LO) can be selected for the measurement accuracy.

The termination value, sample mass, minimum displayed (%), and minimum displayed (g) are automatically selected according to the measurement accuracy.

The selected values are as follows.

Model	Measurement conditions	Measurement accuracy setting: ACCURACY		
		Accuracy priority ↔		Speed priority
		HI	MID.	LO
MS-74A	Termination value	0.01%/min	0.02%/min	0.10%/min
	Sample mass	10 g	5 g	1 g
	Minimum displayed (%)	0.001%	0.001%	0.01%
	Minimum displayed (g)	0.001 g		
MX-53A	Termination value	0.02%/min	0.05%/min	0.50%/min
	Sample mass	10 g	5 g	1 g
	Minimum displayed (%)	0.01%	0.01%	0.1%
	Minimum displayed (g)	0.001 g		
MF-53A	Termination value	0.05%/min	0.10%/min	0.50%/min
	Sample mass	10 g	5 g	1 g
	Minimum displayed (%)	0.05%	0.05%	0.1%
	Minimum displayed (g)	0.002 g		
ML-53A	Termination value	0.10%/min	0.20%/min	0.50%/min
	Sample mass	10 g	5 g	1 g
	Minimum displayed (%)	0.1%	0.1%	1%
	Minimum displayed (g)	0.005 g		

Changing the Measurement Accuracy (Standard Mode Only)

Step	Description	Example Display
1.	<p>Refer to "6.4.1. How to Select Measurement Conditions" to select the operation for changing the measurement accuracy.</p> <p>The current measurement accuracy flashes.</p> <p>↑ ↓ keys Change the measurement accuracy.</p>	

6.4.6. Termination value

This can only be selected with the custom mode.

Because the moisture decreases as the sample dries, the change in moisture content per unit time decreases. When the change in moisture content per minute becomes lower than the set value, drying is deemed to have ended and measurement stops.

The available settings are as follows.

	Available range of settings			
	MS-74A	MX-53A	MF-53A	ML-53A
2.00 %/min	↑	↑	↑	↑
1.00 %/min				
0.50 %/min				Available
0.20 %/min			Available (default setting)	(default setting)
0.10 %/min		Available (default setting)	(default setting)	
0.05 %/min	Available (default setting)	(default setting)		
0.02 %/min			↓	
0.01 %/min			Unavailable	
0.005 %/min				
0.002 %/min				
0.001 %/min				

Configuring the Termination Value (Custom Mode Only)

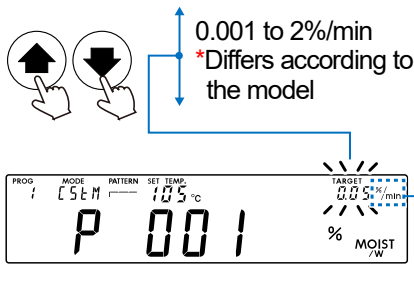
Step	Description	Example Display
1.	<p>The current termination value flashes as indicated in "6.4.1. How to Select Measurement Conditions".</p> <p>*Confirm that "%/min" is displayed as the unit for the value.</p> <p>↑ ↓ keys Change the value set for the termination value.</p>	 <p>0.001 to 2%/min *Differs according to the model</p> <p>Confirm that "%/min" is lit.</p>

6.4.7. Configuring the Sample Mass

The sample mass can be configured with the timer mode or custom mode.

Set the upper limit value and lower limit value for loading the sample. When the mass is displayed, the average value of the upper limit value and lower limit value is displayed. The amount to load can be adjusted according to the displayed level meter.

If the sample mass is outside the range of setting values when the sample mass is set in the timer mode or custom mode, heating cannot be started by pressing the **START** key.



CAUTION

- If the sample mass is set to the default value (0 g for both the upper limit and lower limit), the level meter is not displayed and there is no limit on the heating start time.
- If the lower limit is set to 0 g and the upper limit is set to a value other than 0 g, the operation is the same as if 0.1 g was set for the lower limit.
- If the upper limit is set to 0 g and the lower limit is set to a value other than 0 g, the operation is the same as if the maximum value was set for the upper limit. (51 g for the MX-53A, MF-53A, and ML-53A. 71 g for the MS-74A.)
- If a value other than 0 g is set for both the upper limit and lower limit and a value at or below the lower limit is set for the upper limit, an error is displayed then the screen for setting the upper limit is displayed.

Example Level Meter Display

Sample mass	Level meter display
Lower than the set lower limit	<p>The display shows a level meter with a scale from 0 to 10. The upper limit is marked with a minus sign (-) at 10 and the lower limit with a plus sign (+) at 0. The current mass is indicated by a downward-pointing triangle (▼) at approximately 1.5. The meter shows three bars of height 1.5, representing the current mass.</p>
Within range of set values	<p>The display shows a level meter with a scale from 0 to 10. The upper limit is marked with a minus sign (-) at 10 and the lower limit with a plus sign (+) at 0. The current mass is indicated by a downward-pointing triangle (▼) at approximately 5.5. The meter shows five bars of height 5.5, representing the current mass.</p>
Higher than the set upper limit	<p>The display shows a level meter with a scale from 0 to 10. The upper limit is marked with a minus sign (-) at 10 and the lower limit with a plus sign (+) at 0. The current mass is indicated by a downward-pointing triangle (▼) at approximately 10.5. The meter shows ten bars of height 10, representing the upper limit.</p>

Setting the Sample Mass (Timer Mode or Custom Mode Only)

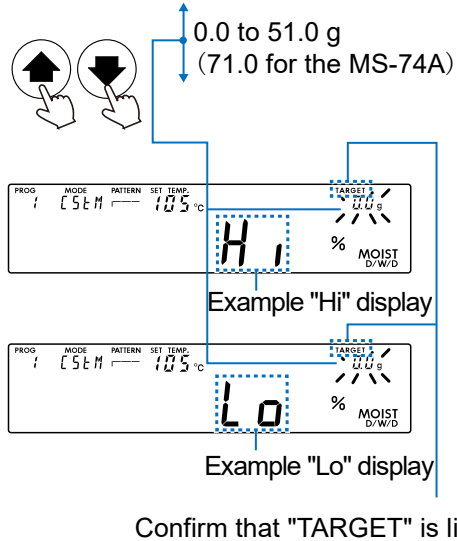
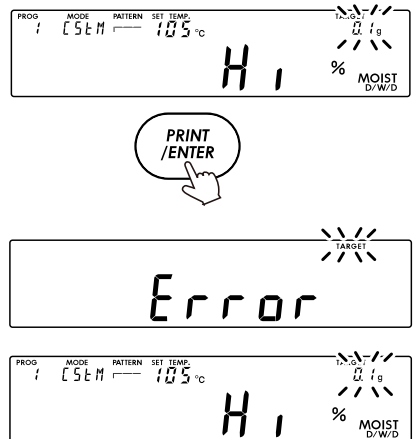
Step	Description	Example Display
1.	<p>The current sample mass value flashes as indicated in "6.4.1. How to Select Measurement Conditions".</p> <p>*Confirm that "TARGET" is displayed above the sample mass.</p> <p>"Lo" is displayed when changing the lower limit and "Hi" is displayed when changing the upper limit.</p> <p>  keys Change the set sample mass (upper limit or lower limit) value.</p>	 <p>0.0 to 51.0 g (71.0 for the MS-74A)</p> <p>Example "Hi" display</p> <p>Example "Lo" display</p> <p>Confirm that "TARGET" is lit.</p>
Remarks	<p>Example: Operation when an error occurs</p> <p>An error occurs if the upper limit of the sample mass is set to a value that is smaller than the lower limit.</p> <p>When the heating conditions are confirmed, an error is displayed and the screen for setting the upper limit of the sample mass is displayed.</p>	 <p>PRINT/ENTER</p> <p>Error</p>

6.4.8. Measurement Basis



Unit	Formula of displayed value	Display
Moisture content (standard before drying) ^{*1}	$\frac{W - D}{W} \times 100$	% MOIST /W
Moisture content (Atro) (standard after drying) ^{*2}	$\frac{W - D}{D} \times 100$	% MOIST /D
Solids	$\frac{D}{W} \times 100$	% RATIO D/W
Ratio ^{*2}	$\frac{W}{D} \times 100$	% RATIO W/D
Grams	-	g

W: Sample mass before drying D: Sample mass after drying

*1 Default setting

*2 If the sample mass decreases after drying and the measured value exceeds 999%, operation automatically stops because the measurement results cannot be calculated correctly.

Changing the Measurement Basis

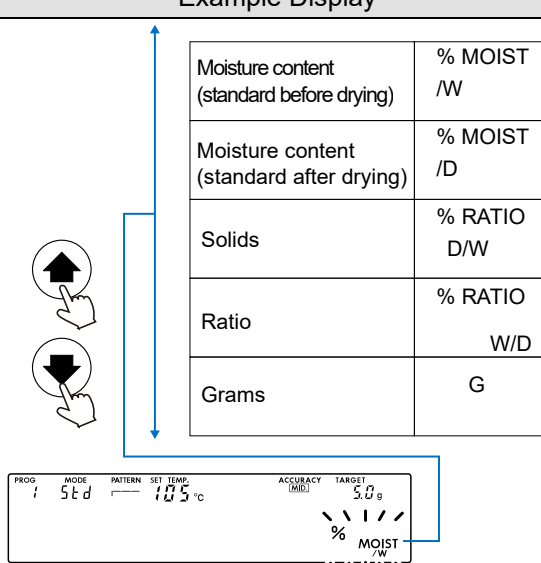

Step	Description	Example Display																						
1.	<p>Refer to "6.4.1. How to Select Measurement Conditions" to select the operation for changing the measurement basis.</p> <p>The current measurement basis flashes.</p> <p>  keys Change the measurement basis.</p>	 <table border="1"> <tbody> <tr> <td>Moisture content (standard before drying)</td> <td>% MOIST /W</td> </tr> <tr> <td>Moisture content (standard after drying)</td> <td>% MOIST /D</td> </tr> <tr> <td>Solids</td> <td>% RATIO D/W</td> </tr> <tr> <td>Ratio</td> <td>% RATIO W/D</td> </tr> <tr> <td>Grams</td> <td>G</td> </tr> </tbody> </table> <table border="1"> <thead> <tr> <th>PROG</th> <th>MODE</th> <th>PATTERN</th> <th>SET TEMP.</th> <th>ACCURACY (IME)</th> <th>TARGET</th> </tr> </thead> <tbody> <tr> <td>1</td> <td>Std</td> <td></td> <td>105 °C</td> <td></td> <td>5.0 g</td> </tr> </tbody> </table> <p style="text-align: center;">% MOIST /W</p>	Moisture content (standard before drying)	% MOIST /W	Moisture content (standard after drying)	% MOIST /D	Solids	% RATIO D/W	Ratio	% RATIO W/D	Grams	G	PROG	MODE	PATTERN	SET TEMP.	ACCURACY (IME)	TARGET	1	Std		105 °C		5.0 g
Moisture content (standard before drying)	% MOIST /W																							
Moisture content (standard after drying)	% MOIST /D																							
Solids	% RATIO D/W																							
Ratio	% RATIO W/D																							
Grams	G																							
PROG	MODE	PATTERN	SET TEMP.	ACCURACY (IME)	TARGET																			
1	Std		105 °C		5.0 g																			

6.4.9. Minimum Displayed (Percentage/Grams)

The available minimum selectable for each model is indicated in the table below.

Model	Minimum displayed	
	% (percentage)	g (grams)
MS-74A	0.001%	0.0001 g
	0.01%	0.001 g
	0.1%	0.01 g
		0.1 g
MX-53A	0.01%	0.001 g
	0.1%	0.01 g
		0.1 g
MF-53A	0.05%	0.002 g
	0.1%	0.01 g
	1%	0.1 g
ML-53A	0.1%	0.005 g
	1%	0.01 g
		0.1 g

Changing the Displayed Digits (Percentage/Grams)

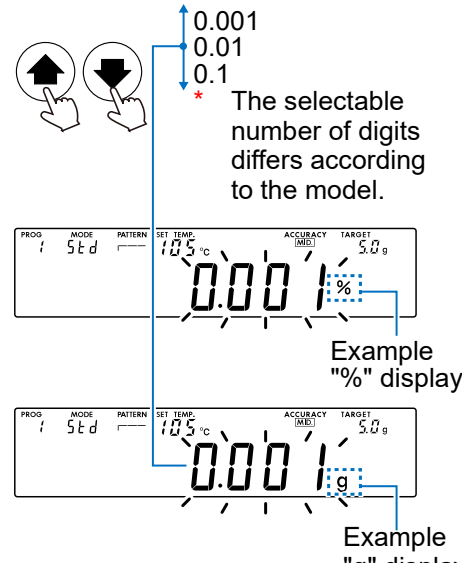
Step	Description	Example Display
1.	<p>Refer to "6.4.1. How to Select Measurement Conditions" to select the operation for changing the displayed digits (to percentage or grams).</p> <p>The displayed digits that are currently set flash.</p> <p>When changing the displayed digits for the percentage display, "%" is displayed for the unit.</p> <p>When changing the displayed digits for the grams display, "g" is displayed for the unit.</p> <p>  keys Change the displayed digits that are set.</p>	 <p>The selectable number of digits differs according to the model.</p> <p>Example "%" display</p> <p>Example "g" display</p>

6.4.10. Comparator Values

You can set an upper limit and lower limit for the comparator.

To configure the comparator function, it must first be enabled in the internal settings.

You can set an upper limit and lower limit for the comparator that are between 0.0 to 999.9%.

The comparator result is displayed on the screen when measurement stops and is appended to the GLP output and output for the measurement result of the data memory function.

CAUTION

- If the comparator function is disabled in the internal settings, the comparator result is not displayed.
- If the comparator is set to the default value (0% for both the upper limit and lower limit), the comparator result is not displayed.
- If the upper limit of the comparator is set to 0% and the lower limit is set to a value other than 0%, only the lower limit is compared.
- If a value other than 0% is set for the upper limit of the comparator and a value at or above the upper limit is set for the lower limit, an error is displayed then the screen for setting the upper limit is displayed.

Example Measurement Result

Comparator result flashes

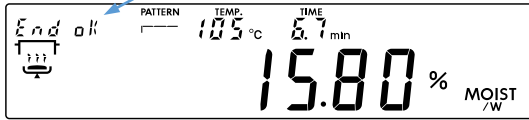

Display of moisture analyzer

```

A & D
MODEL MX-53A
S/N P1234567
ID LAB-123
PROGRAM No. 1
PROGRAM ID
P 001
MODE STANDARD
MID.
DRYING STANDARD
105 C
UNIT MOIST /W
OFFSET 1.23 %
-----
INITIAL WEIGHT
5.678 g
FINAL WEIGHT
4.567 g
RESULT MOIST /W
19.57 %
JUDGMENT OK
ANALYSIS TIME
6.7min
DATE 2024/08/01
TIME 12:34:56
REMARKS
-----
SIGNATURE
-----
    
```

GLP output (output together when info = 1)

```

INITIAL WEIGHT
5.039 g
FINAL WEIGHT
4.242 g
RESULT MOIST W
15.80 %
JUDGMENT OK
ANALYSIS TIME
6.7min
DATE 2024/08/01
TIME 12:34:56
REMARKS
-----
    
```

GLP output (output separately)

```



PROGRAM No. 1
PROGRAM ID
P 001
MODE STANDARD
MID.
DRYING STANDARD
105 C
RESULT MOIST /W
15.80 %
JUDGMENT OK
DATE 2024/08/01
TIME 12:34:56
-----
    
```

Data memory output

Comparator result

Comparator result

Configuring the Upper Limit and Lower Limit of the Comparator

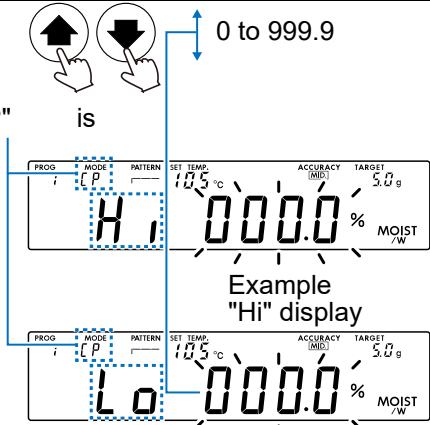
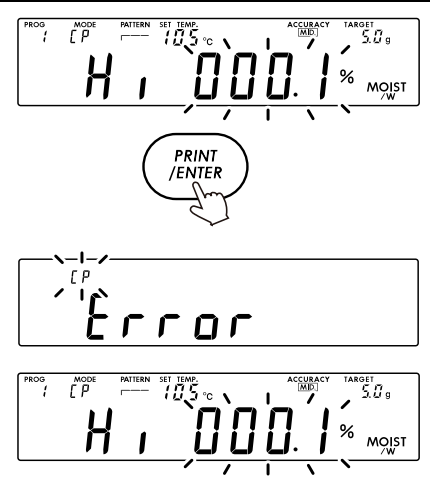
Step	Description	Example Display
1.	Set [P] (comparator mode) in <i>PrG Fnc</i> (additional functions for measurement conditions) to (enabled) in "8. Internal Settings".	
2.	<p>Refer to "6.4.1. How to Select Measurement Conditions" to select the operation for changing the comparator values.</p> <p>Confirm that the current comparator settings are flashing.</p> <p>"CP" is displayed for the mode.</p> <p>H is displayed when changing the upper limit of the comparator.</p> <p>L is displayed when changing the lower limit of the comparator.</p> <p>  keys Changes the displayed digits that are set.</p>	<p>0 to 999.9</p> <p>"CP" is</p>  <p>Example "Hi" display</p> <p>Example "Lo" display</p>
Remarks	<p>Example: Operation when an error occurs</p> <p>An error occurs if a value lower than the lower limit is input for the upper limit of the comparator. When the heating conditions are confirmed, an error is displayed and the screen for setting the upper limit of the comparator is displayed.</p>	

6.4.11. Correction of measurement results

- The result of measuring the moisture content can be corrected.
- This function is intended for use when a moisture analyzer made by another manufacturer is replaced by this instrument and the measurement results do not match previous values due to differences in model or measurement method, even when the measurement conditions and sample conditions are the same.
- This function is used to correct measurement results when it is necessary to maintain consistency with past measurement results.

Model	Range of corrected result values
MS-74A	-9.999% to 9.999%
MX-53A	-9.99% to 9.99%
MF-53A	-9.95% to 9.95%
ML-53A	-9.9% to 9.9%
Default setting (no correction)	0%



Formula

The displayed moisture content equals the moisture content that is actually measured plus the correction value.

CAUTION

- If the measured value is negative, 0% is displayed for the moisture content.
- Correction is not performed if the correction value is 0% or moisture content correction is disabled.
- The correction value is appended to the GLP output.

Correction of measurement results

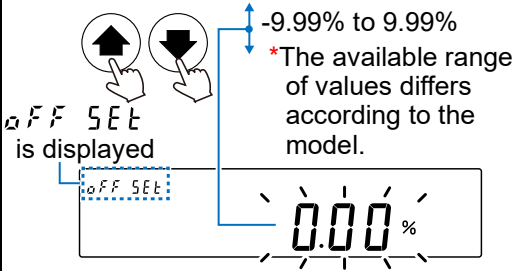
Step	Description	Example Display
1.	Set $\square \square \square \square \square \square$ (moisture content measurement result correction) in $P r \square F n c$ (additional functions for measurement conditions) to \square (enabled) in "8. Internal Settings".	
2.	Refer to "6.4.1. How to Select Measurement Conditions" to select the operation for changing the result correction value. Confirm that the current result correction value is flashing. $\square \square \square \square \square \square$ is displayed.   keys Change the displayed digits that are set.	 <p>-9.99% to 9.99% *The available range of values differs according to the model.</p>

```

A & D
MODEL    MX-53A
S/N      P1234567
ID       LAB-123
PROGRAM  No. 1
PROGRAM ID
          P 001
MODE STANDARD
          MID.
DRYING STANDARD
          105 C
UNIT     MOIST /W
OFFSET   1.23 %
-----
INITIAL WEIGHT      5.678 g
FINAL WEIGHT        4.567 g
RESULT MOIST /W    19.57 %
JUDGMENT           OK
ANALYSIS TIME      6.7min
DATE 2024/08/01
TIME 12:34:56
REMARKS

-----
SIGNATURE
-----

```

GLP output (output together when info = 1)

```

A & D
MODEL    MX-53A
S/N      P1234567
ID       LAB-123
PROGRAM  No. 1
PROGRAM ID
          P 001
MODE STANDARD
          MID.
DRYING STANDARD
          105 C
UNIT     MOIST /W
OFFSET   1.23 %

```

GLP output (output separately)

Correction of measurement results

Correction of measurement results

6.4.12. Program ID









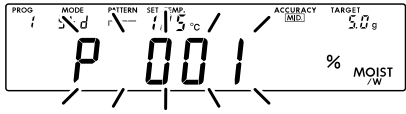

A seven character name can be set for the parameter.

The following characters can be used.

0	1	2	3	4	5	6	7	8	9	-	_	A	B	C	D	E	F	G	H	I	J	K	L	M	N	O	P	Q	R	S	T	U	V	W	X	Y	Z
0	1	2	3	4	5	6	7	8	9	-	_	A	B	C	D	E	F	G	H	I	J	K	L	M	N	O	P	Q	R	S	T	U	V	W	X	Y	Z

_ Space

Changing the Program ID

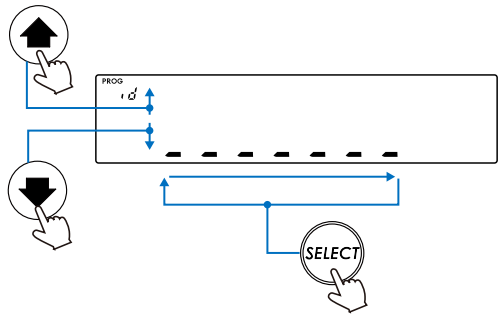



Step	Description	Example Display
1.	Refer to "6.4.1. How to Select Measurement Conditions" to select the operation for changing the program ID. Confirm that the current program ID is flashing.	
2.	Press the  or  key.	 or 
3.	Screen for changing the program ID The selected text flashes.  key Selects the text in the next position.  or  key Changes the selected text.  key Saves the string that is currently displayed and exits.  key Exits without saving the string that is currently displayed.	



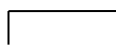

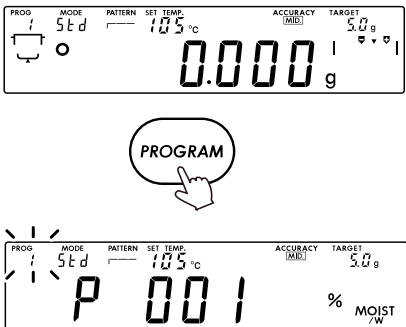



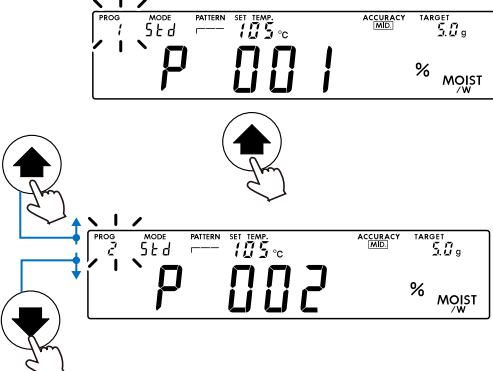
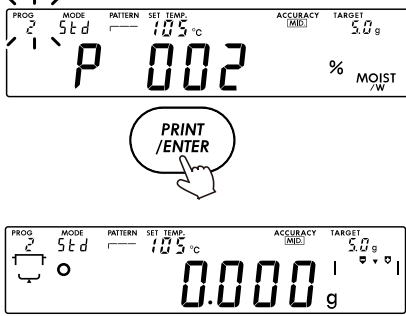
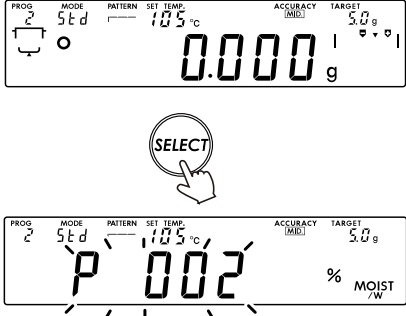

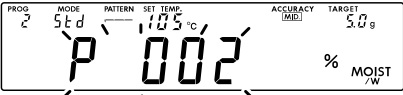

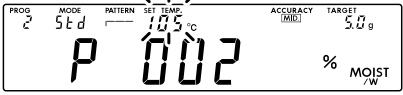

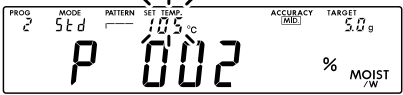

6.5. Examples of Changing the Measurement Conditions

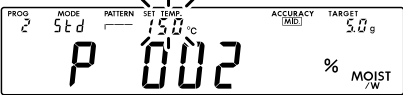
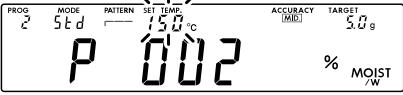

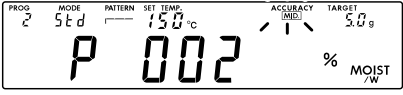

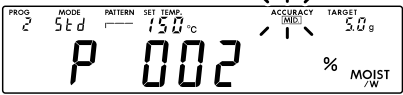

6.5.1. Example 1 (Standard Conditions)

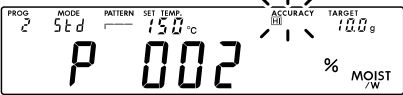
This example describes how to configure the following conditions for program number 2 with the MX-53A.

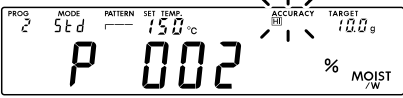
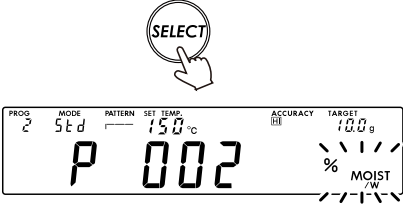
Measurement condition	Set value	Description/purpose	
Program number	2		
Program ID	No change.		
Measurement mode	Standard mode	<i>Std</i>	The sample amount and termination value for moisture content measurement are automatically set based on the set measurement accuracy.
Heating pattern	Standard heating		Heating is performed at a constant temperature.
Temperature	Heating temperature	150°C	
Measurement accuracy	High	HI	This can only be selected with the standard mode. (Refer to " 6.3.2. Available Measurement Conditions ".)
Measurement basis	Moisture content (standard before drying)	% MOIST /W	

Step	Description	Operation
1.	Press the PROGRAM key with the mass displayed to display the screen for selecting the measurement conditions.	
2.	Press  to make 2 flash. *   enables you to change the program number.	
3.	Press the ENTER key to confirm the program number.	
4.	Press the SELECT key to display the screen for changing the measurement conditions.	

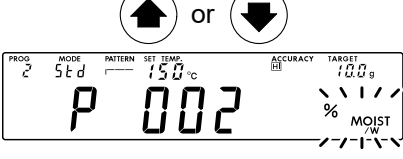
Step	Description	Operation
5.	Press the SELECT key several times to display the screen for changing the temperature setting.	  Press several times 
6.	Press the  key to display 150°C. You can press and hold the key to change the temperature value more quickly. *The   keys enable you to change the value.	  
7.	Press the SELECT key to display the screen for changing the accuracy.	  
8.	Press the  key to select "HI". * The   keys enable you to change the accuracy.	  

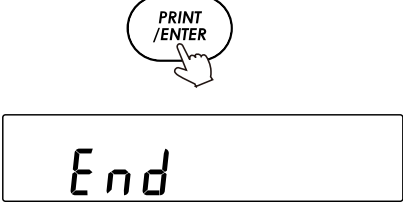
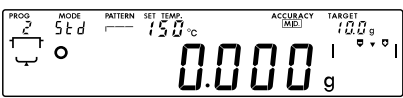
Step	Description	Operation
9.	Press the SELECT key to display the screen for changing the measurement basis.	 
10.	<p>If necessary, press the   keys to display % $\text{MOIST}_{/W}$.</p> <p>* % $\text{MOIST}_{/W}$ is selected by default.</p>	 
11.	<p>Press the ENTER key to save all the settings. End is displayed, then the screen switches to the mass display.</p> <p>To perform moisture content measurement with the changed settings, refer to "5. Measurement".</p>	  

6.5.2. Example 2 (Complex Conditions)

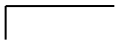

This example describes how to configure the following conditions for program number 3 with the MX-53A.









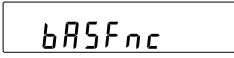

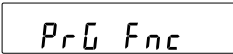

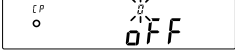

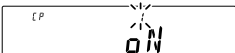

Measurement condition		Set value	Description/purpose
Program number		3	
Program ID		No change.	
Measurement mode	Timer mode	TIME	Measurement stops when a certain period of time has elapsed since measuring the moisture content.
Heating pattern	Standard heating		Heating is performed at a constant temperature.
Temperature	Heating temperature	120°C	
Time	Heating time	15 min	
Sample mass	Hi	11 g	
	Lo	9 g	
Measurement basis	Moisture content (standard after drying)	% MOIST /D	
Minimum displayed	Percentage	0.1%	*The available values differ according to the model. Refer to "6.4.9. Minimum Displayed (Percentage/Grams)".
	Grams	0.01 g	
Comparator	Hi	010.0%	
	Lo	008.0%	
Correction of measurement results		1.00%	Added to the moisture content.

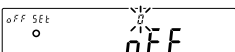

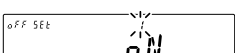

Preparing to Configure the Measurement Conditions

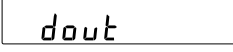



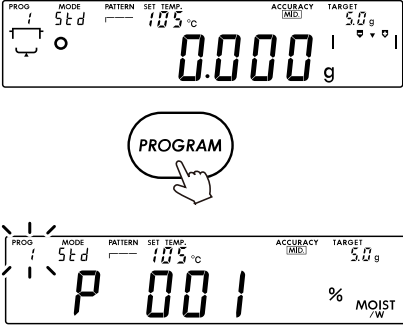



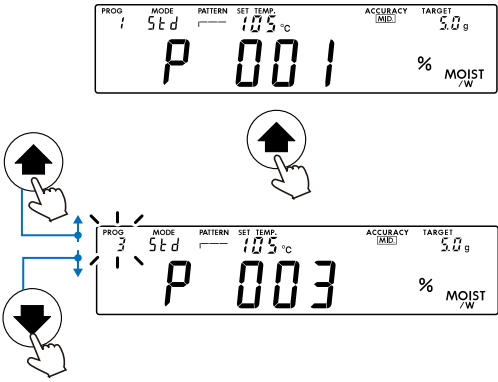
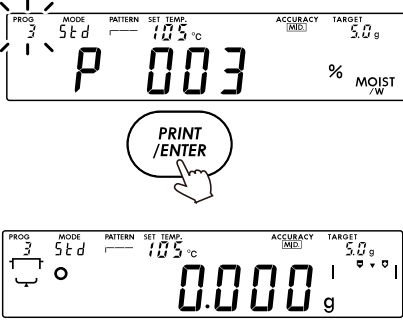
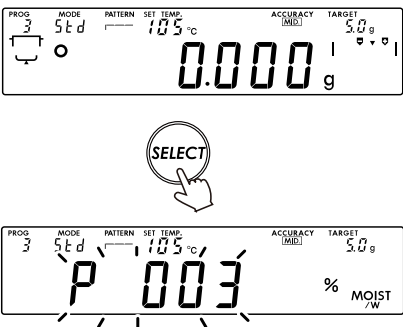

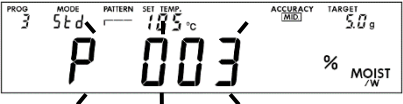

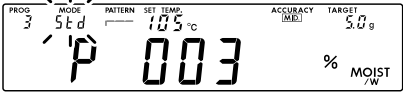

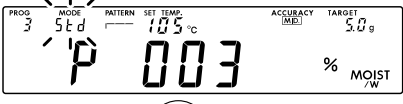

Enable the comparator and correction of measurement results functions in the internal settings.

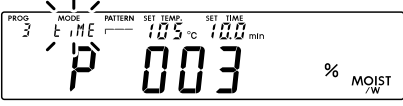
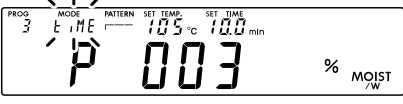





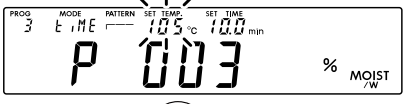

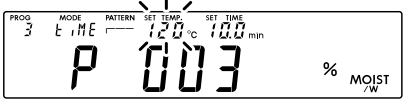
For details on the internal settings, refer to "8. Internal Settings".

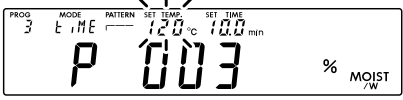
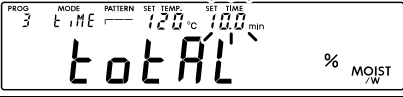



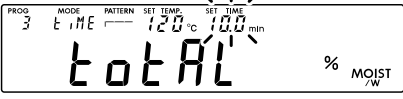
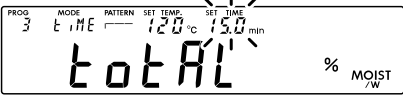
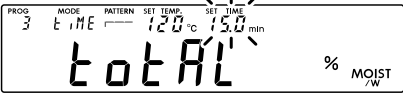
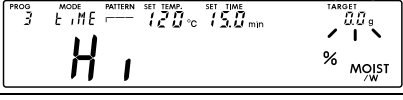

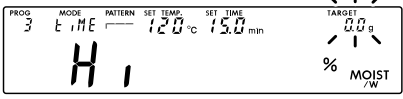
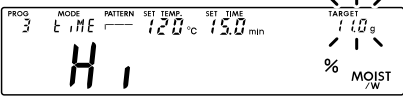

Step	Description	Category	Setting
1.	Press and hold the SELECT key (for approx. two seconds) with the mass displayed to display <i>bASFnc</i> .	  Press and hold (for approx. two seconds)  "Environment/Display"	

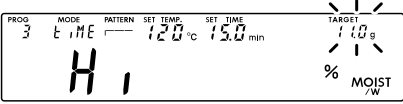
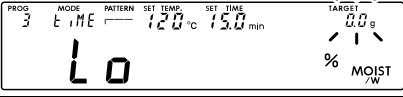



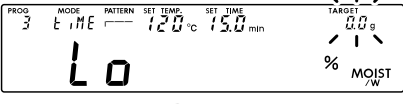
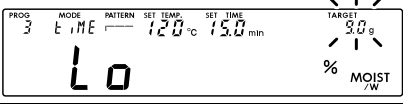
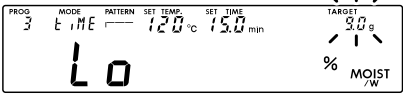
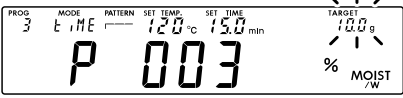



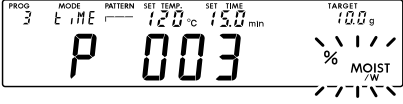
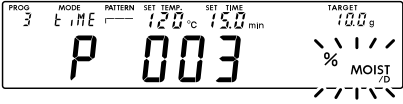

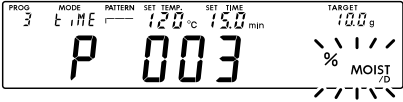
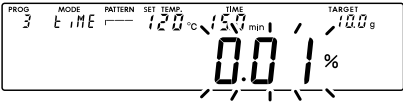
Step	Description	Category	Setting
2.	Press the SELECT key several times to display the additional functions (<i>P r G F n c</i>) for the measurement conditions.	 Press several times  "Additional Functions for Measurement Conditions"	
3.	Press the ENTER key to enter the additional functions (<i>P r G F n c</i>) for the measurement conditions.		 "Comparator Mode" "oFF"
4.	Use the   keys to change the comparator function (<i>CP</i>) to <i>!</i> (enabled).	 	 "Comparator Mode" "oN"
5.	Press the SELECT key to display the setting for the result correction of moisture content measurement.		 "Moisture Content Measurement Result Correction" "oFF"
6.	Use the   keys to change moisture content measurement result correction (<i>OFF SEt</i>) to <i>!</i> (enabled).	 	 "Moisture Content Measurement Result Correction" "oN"
7.	Press the ENTER key to confirm the changes.	  "Data Output"	
8.	Press the RESET key to exit the screen for changing the settings. The screen returns to the mass display.	 	



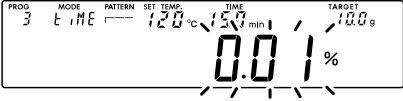
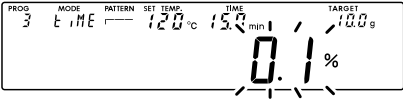
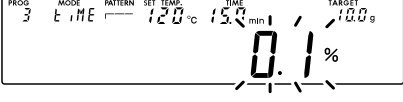





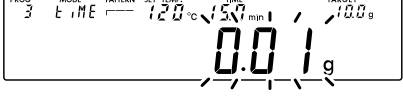





Step	Description	Operation
1.	Press the PROGRAM key with the mass displayed to display the screen for selecting the measurement conditions.	
2.	Press the  key to make 3 flash. *The   keys enable you to change the program number.	
3.	Press the ENTER key to confirm the program number.	
4.	Press the SELECT key to display the screen for changing the measurement conditions.	







Step	Description	Operation
5.	Press the SELECT key once to display the screen for changing the measurement mode.	  Press several times 
6.	Press the  key to display <i>t, ME</i> . *The   keys enable you to change the display.	  
7.	Press the SELECT key several times to display the screen for changing the temperature setting.	  
8.	Press the  key to display 120°C. You can press and hold the key to change the temperature value more quickly. *The   keys enable you to change the value.	  

Step	Description	Operation
9.	Press the SELECT key to display the screen for changing the time setting.	 
10.	Press the  key several times to display 15.0 min. You can press and hold the key to change the time value more quickly. *The   keys enable you to change the value.	 <p data-bbox="1050 775 1289 801">Press several times</p> 
11.	Press the SELECT key to display the screen for changing the sample mass upper limit setting.	 
12.	Press the  key several times to display 11.0 g. You can press and hold the key to change the value more quickly. *The   keys enable you to change the value.	 <p data-bbox="1098 1547 1337 1574">Press several times</p> 

Step	Description	Operation
13.	Press the SELECT key to display the screen for changing the sample mass lower limit setting.	 
14.	Press the  key several times to display 9.0 g. You can press and hold the key to change the value more quickly. *The   keys enable you to change the value.	 <p data-bbox="1098 775 1337 801">Press several times</p> 
15.	Press the SELECT key to display the screen for changing the unit setting.	 
16.	Press the  key to display % MOIST _D . *The   keys enable you to change the unit.	 

Step	Description	Operation
17.	Press the SELECT key to display the screen for changing the decimal point position setting for the percentage display.	 
18.	Press the  key to display 0.1%. *The   keys enable you to change the displayed digits.	 
19.	Press the SELECT key to display the screen for changing the decimal point position setting for the grams display.	 
20.	Press the  key to display 0.01 g. *The   keys enable you to change the displayed digits.	 

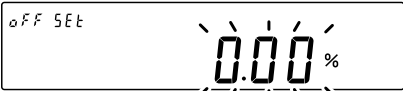
Step	Description	Operation
21.	<p>Press the SELECT key to display the screen for changing the maximum value setting of the comparator.</p> <p>*This is only displayed if the setting for the comparator function ([P]) is set to 1 (enabled) in the internal settings. For information on changing the internal settings, refer to "8. Internal Settings".</p>	 
22.	<p>Press the  key several times to display 010.0%.</p> <p>You can press and hold the key to change the value more quickly.</p> <p>*The   keys enable you to change the value.</p>	 <p>Press several times</p> 
23.	<p>Press the SELECT key to display the screen for changing the minimum value setting of the comparator.</p> <p>*This is only displayed if the setting for the comparator function ([P]) is set to 1 (enabled) in the internal settings. For information on changing the internal settings, refer to "8. Internal Settings".</p>	 
24.	<p>Press the  key several times to display 008.0%.</p> <p>You can press and hold the key to change the value more quickly.</p> <p>*The   keys enable you to change the value.</p>	 <p>Press several times</p> 

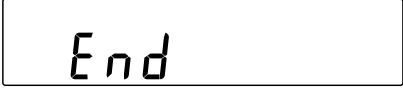
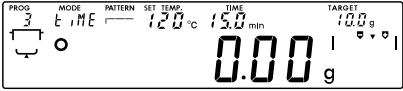
Step	Description	Operation
25.	<p>Press the SELECT key to display the screen for changing the correction of measurement results setting.</p> <p>*This is only displayed if the setting for moisture content measurement result correction (OFF SET) is set to 1 (enabled) in the internal settings. For information on changing the internal settings, refer to "8. Internal Settings".</p>	 
26.	<p>Press the  key several times to display 1.00%.</p> <p>You can press and hold the key to change the value more quickly.</p> <p>*The   keys enable you to change the value.</p>	 <p>Press several times</p> 
27.	<p>Press the ENTER key to save all the settings. End is displayed, then the screen switches to the mass display.</p> <p>To perform moisture content measurement with the changed settings, refer to "5. Measurement".</p>	  

7. Function Tests and Adjustment

This section describes the function tests included in the product for checking operation and the sensitivity adjustment for the mass sensor and heating temperature.

7.1. Function Tests and Adjustment Modes

The product contains the following function tests and adjustment modes.

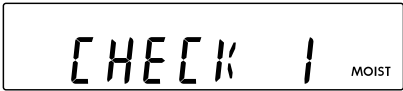
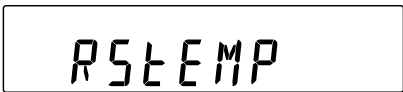
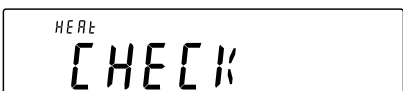
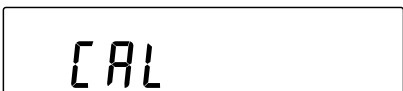
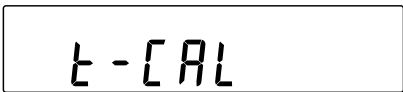
Name	Display	Description
Moisture content measurement check 1		Uses a test sample (sodium tartrate dihydrate) to check whether moisture content measurement is performed correctly.
RSTEMP		Automatically determines the recommended heating temperature by performing test heating of a sample for which the appropriate heating temperature is unknown.
Heater check		Confirms that the heater is operating.
Mass sensor sensitivity adjustment		Adjusts the sensitivity of the mass sensor.
Heating temperature adjustment		Adjusts the heating temperature.

7.2. Test Sample Function Check





Regarding the test sample (sodium tartrate dihydrate)

- Sodium tartrate dihydrate ($\text{Na}_2\text{C}_4\text{H}_4\text{O}_6/2\text{H}_2\text{O}$) can be used for checking the performance of the moisture analyzer. Sodium tartrate includes 15.66% moisture in theory but this value differs according to how the substance is stored.
- Normally, the following measurement method will give a moisture content of 15.0 to 16.0% (standard before drying).
- Sodium tartrate is also used as a food additive, but may irritate the eyes and nose. If it gets on your skin, wash it away with water.
- Dispose of the sodium tartrate after measurement as burnable waste. It cannot be reused.
- Sodium tartrate is included with the MS-74A/MX-53A.
For the MF-53A/ML-53A, sodium tartrate is available separately.

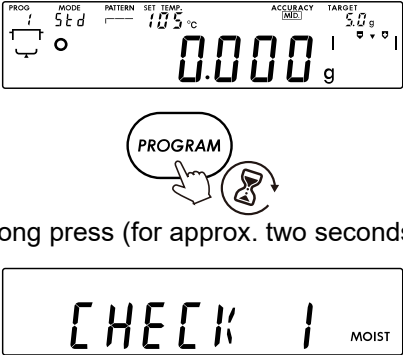
CAUTION

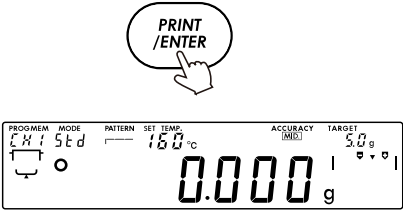
- If the sample tray is hot before measurement starts, measurement error may occur.

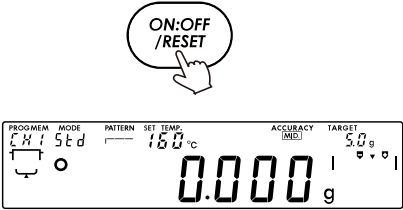
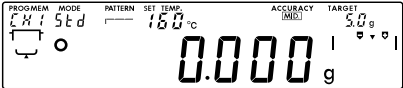
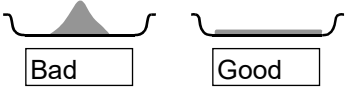
Step	Description	Operation
1.	Press and hold the PROGRAM key (for approx. two seconds) with the mass displayed to display moisture content measurement check 1 (CHECK 1 <small>MOIST</small>).	 <p>The diagram illustrates the process of entering the moisture content measurement check mode. It shows the analyzer's display with various parameters: PROG (1), MODE (5Ed), PATERN (—), SET TEMP. (105 °C), ACCURACY (MED), and TARGET (5.0 g). The main display shows 0.000 g. Below the display, a hand is shown pressing the PROGRAM key, which is highlighted with a callout. A long press icon (a hand holding a button for a duration) is also shown. Below this, the display shows the text 'CHECK 1' and 'MOIST'.</p> <p>Long press (for approx. two seconds)</p>

Step	Description	Operation
2.	<p>Press the ENTER key to switch to moisture content measurement check 1 (CHECK 1 <small>MOIST</small>).</p> <p>The measurement conditions are automatically set to the following recommended conditions.</p> <p>Measurement conditions</p> <ul style="list-style-type: none"> Measurement mode: Standard measurement mode Heating pattern: Standard heating Temperature: 160°C Measurement accuracy: MID. Sample mass Maximum mass value: 6.0 g Minimum mass value: 4.0 g Measurement basis: Moisture content (standard before drying) Comparator Maximum: 16.0% Minimum: 15.4% <p>To return to the mass display without executing the check, press the STOP key.</p>	 
3.	<p>Press the RESET key to reset the displayed mass value to zero.</p>	 
4.	<p>Place the test sample flat on the sample tray.</p>	  

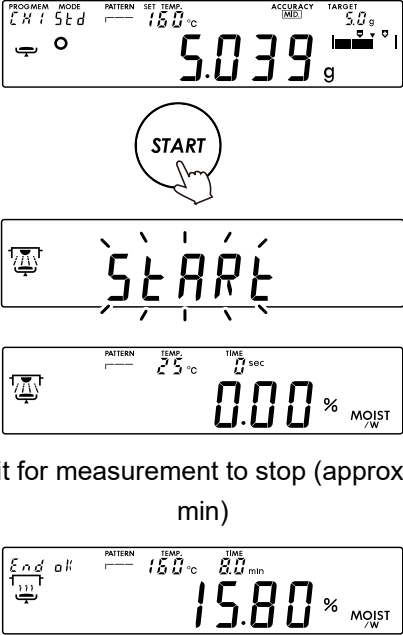
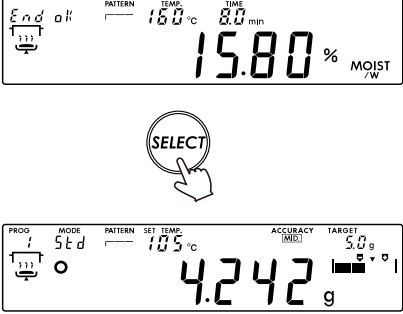
Step	Description	Operation
5.	<p>Close the lid, then press the START key to start measuring the moisture content.</p> <p>Approx. 10 minutes later, the measurement result is displayed.</p> <p>The product is operating normally if the measurement result is between 15.4 and 16.0% (if OK is displayed by the comparator function).</p>	 <p>Wait for measurement to stop (approx. 10 min)</p>
6.	<p>The product is operating normally if the measurement result is between 15.4 and 16.0% (if OK is displayed by the comparator function).</p> <p>If GLP output is set, the result of checking the product functionality with a test sample is output after the operation is finished.</p> <p>(Refer to "inFo (GLP output)" in "dout (data output)" in "8. Internal Settings".)</p> <p>For information on the output result, refer to "9.3.3. Test Sample Output for Function Check".</p> <p>Press the SELECT key to return to the mass display.</p>	







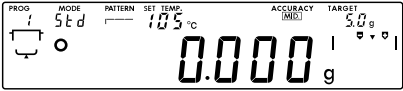

7.3. RS TEMP (Heating Temperature Detection Function)

Regarding RS TEMP

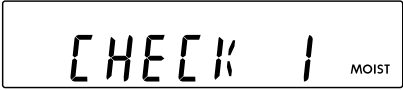





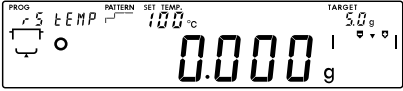

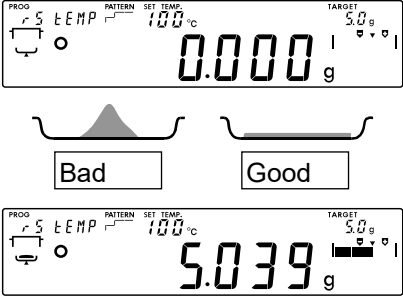
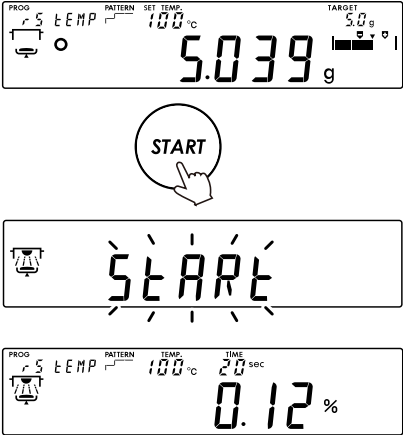
- This function automatically determines the recommended heating temperature based on changes in the moisture content when performing test heating at multiple temperatures (100 to 200°C) on a sample for which the appropriate heating temperature is unknown.
- The recommended heating temperature is displayed after performing test heating. You can also set the recommended temperature as the heating temperature if required.
- It takes about 30 minutes for the temperature to be determined. Test heating is performed at 100°C, 120°C, 140°C, 160°C, 180°C, and 200°C for five minutes each.
- You can connect to a computer and use the RsTemp function of the WinCT-Moisture software to perform test heating for an arbitrary temperature and heating time. (Refer to ["13.4.2. RsTemp Software for Automatic Heating Temperature Detection"](#))

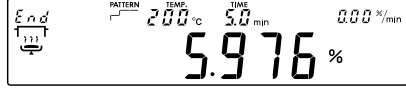
CAUTION

- RsTemp determines the recommended heating temperature based on the measurement and calculated result, but the recommended temperature may not be able to be appropriately determined, depending on the sample type and amount.
- When deciding the heating temperature of the sample, also observe the state of the sample over time by sight and smell, etc. (whether it melts, burns, smells, or disintegrates) and use that information to help decide the heating temperature.

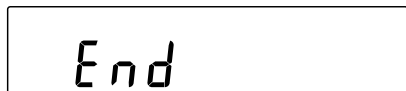
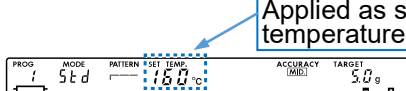
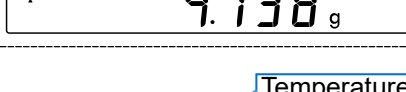
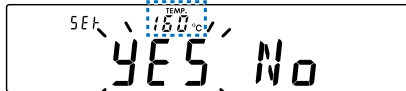
Step	Description	Operation
1.	Press and hold the PROGRAM key (for approx. two seconds) with the mass displayed to display moisture content measurement check 1 (CHECK 1 <small>MOIST</small>).	  Press and hold (for approx. two seconds) 
2.	Press the  key to display RSEMP .	  
3.	Press the ENTER key to switch to RSEMP . To return to the mass display without executing the check, press the STOP key.	  

Step	Description	Operation								
4.	<p>Place the sample to check the heating temperature of flat on the sample tray.</p> <p>Determine the sample amount based on the following.</p> <table border="1" data-bbox="261 394 627 674"> <thead> <tr> <th data-bbox="261 394 456 512">Expected moisture content</th> <th data-bbox="456 394 627 512">Sample amount</th> </tr> </thead> <tbody> <tr> <td data-bbox="261 512 456 595">0 to 0.1%</td> <td data-bbox="456 512 627 595">20 g or more</td> </tr> <tr> <td data-bbox="261 595 456 636">0.1 to 1%</td> <td data-bbox="456 595 627 636">5 g or more</td> </tr> <tr> <td data-bbox="261 636 456 674">1% or higher</td> <td data-bbox="456 636 627 674">2 g or more</td> </tr> </tbody> </table>	Expected moisture content	Sample amount	0 to 0.1%	20 g or more	0.1 to 1%	5 g or more	1% or higher	2 g or more	
Expected moisture content	Sample amount									
0 to 0.1%	20 g or more									
0.1 to 1%	5 g or more									
1% or higher	2 g or more									
5.	<p>Close the lid, then press the START key to start test heating.</p>	 <p style="text-align: center;">• • •</p>								

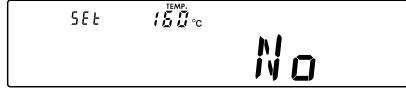
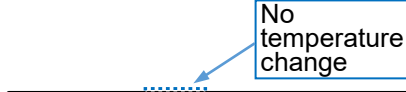
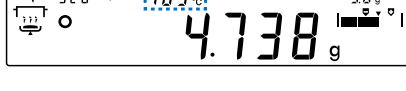



Step	Description	Operation
6.	<p>Approx. 30 minutes later, the estimated heating temperature is displayed.</p> <p>The operation branches with keys as follows.</p>	 
	<p>To set the displayed temperature</p> <p>Press the ENTER key while <i>YES</i> is flashing.</p> <p>The estimated temperature measured in <i>RSEMP</i> is set in the measurement conditions.</p>	    
	<p>To not set the displayed temperature</p> <p>Press the SELECT key to select <i>No</i> (making it flash).</p> <p>Press the ENTER key while <i>No</i> is flashing.</p> <p>The product returns to the mass display without changing the heating temperature.</p>	      





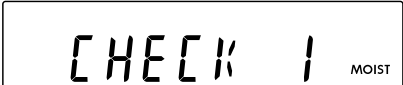

7.4. Self-Inspection

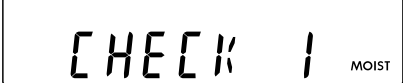
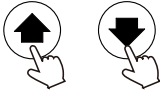
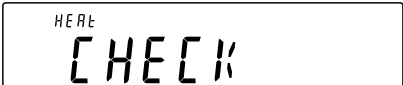
The self-inspection function is used to check the operation of the moisture analyzer. This inspection checks the moisture analyzer for problems when the correct measurement results are not obtained or an operation error is expected. A light is turned on while the function is operating, and temperature control is also checked.

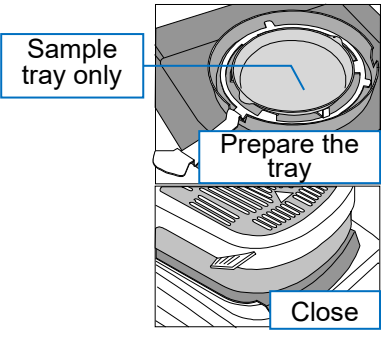
CAUTION

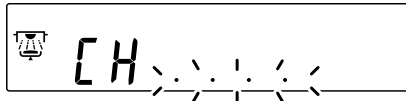
- Do not place flammable objects in the vicinity of the product, as with regular measurement.
- Do not place objects on the heater cover.

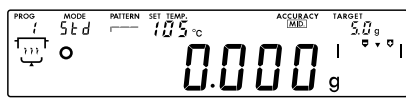
Step	Description	Operation
1.	Press and hold the PROGRAM key (for approx. two seconds) with the mass displayed to display moisture content measurement check 1 (CHECK 1 <small>MOIST</small>).	 <p style="text-align: center;">  PROGRAM Press and hold (for approx. two seconds) </p> 
2.	Press the  or  keys several times to display the heater check (<small>HERE</small> CHECK).	 <p style="text-align: center;">  </p> 

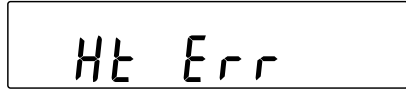
Step	Description	Operation
3.	<p>Load the sample tray holder and sample tray only, close the heater cover, then press the ENTER key.</p> <p>(Align the sample tray handle with the notch of the breeze break.)</p>	  
4.	<p>The check normally finishes in about one minute.</p> <hr/> <p>If the check completes without an error A buzzer sounds, [H PASS] is displayed for a certain period of time, then the product automatically returns to the mass display.</p> <hr/> <p>If an error occurs A buzzer sounds and an error is displayed. *For information on handling the error, refer to "15.6. Errors Displayed".</p> <p>Example errors displayed</p> <p>[H no Error 0 Ht Err</p>	  <p>Example errors displayed</p>   







7.5. Adjusting the Sensitivity of the Mass Sensor







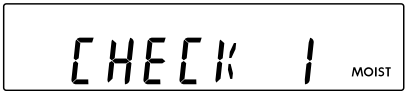
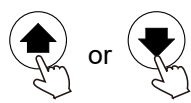
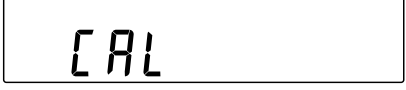
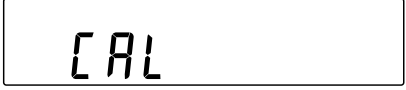

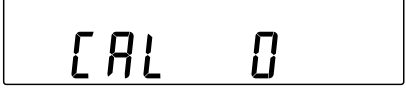





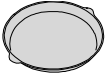

You can use the 20 g or 50 g weight.

It is recommended that you use the 20 g weight for sensitivity adjustment (AD1603-20F1).

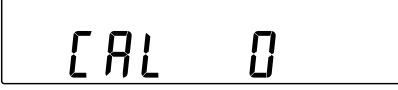
CAUTION

- Avoid disturbance such as vibrations or wind during sensitivity adjustment. Sensitivity adjustment may not be able to be performed if there is disturbance.
- Because a tall weight may touch the top glass of the heater, use a short weight (20 g weight) where possible. When you have no choice but to use a tall weight, perform sensitivity adjustment with the heater cover open. Ensure that there is no disturbance such as wind.

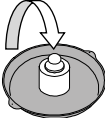
Step	Description	Display and key operation	Operation
1.	Open the heater cover, load the tray holder and sample tray, then close the heater cover.		
2.	Press and hold the PROGRAM key (for approx. two seconds) with the mass displayed to display moisture content measurement check 1 (CHECK 1 <small>MOIST</small>).	  Press and hold (for approx. two seconds)	
3.	Press the  or  keys several times to display the mass sensor sensitivity adjustment (CAL).	  	
4.	Press the ENTER key to switch to mass sensor sensitivity adjustment.	 	
5.	The zero point for sensitivity adjustment is displayed. To change the weight value, proceed to step 6. Otherwise, proceed to step 8.		

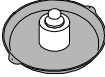

Step	Description	Display and key operation	Operation
6.	Press the SELECT key to display the current weight value.		
7.	Press the  or  key to change the weight value.	  or  	
8.	Press the ENTER key to change the weight value. Press the RESET key to exit without changing the weight value.	  or  	
9.	Confirm that there are no objects on the sample tray, then press the ENTER key with the heater cover closed.	 	
10.	Weigh the zero point. Avoid vibrations.		
11.	The weight value to use for sensitivity adjustment is displayed. Place the weight on the sample tray, then press the ENTER key.	 	
12.	Weigh the weight. Avoid vibrations.		





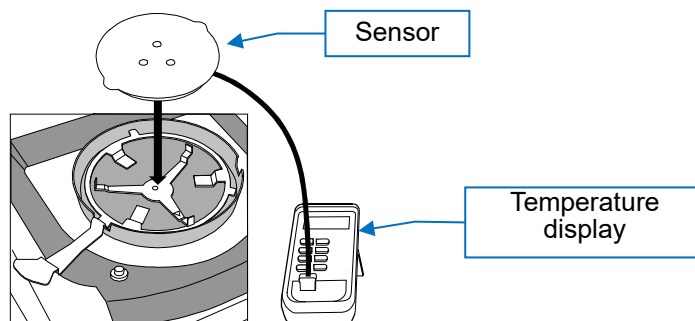

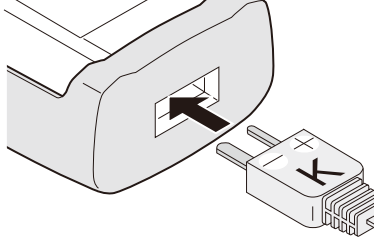

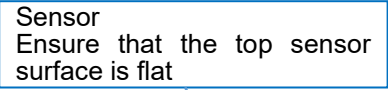
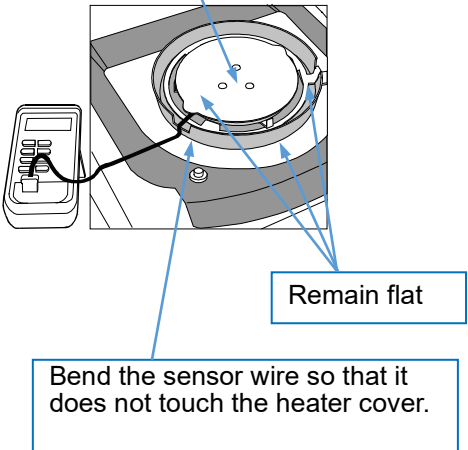
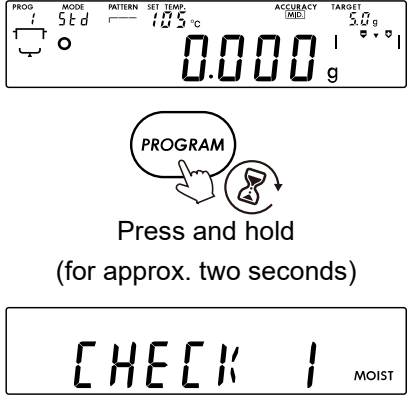



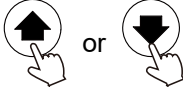

Step	Description	Display and key operation	Operation
13.	Remove the weight from the sample tray.		
14.	If GLP output is set, a sensitivity adjustment record is output after the operation is finished. (Refer to INF_0 (GLP output) in <input type="text" value="dout"/> (data output) in "8. Internal Settings".) For information on the output result, refer to "9.3.4. Mass Sensor Output for Sensitivity Adjustment".	 	
15.	The product automatically returns to the mass display.		



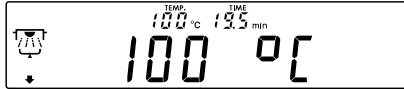



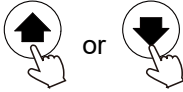

7.6. Adjusting the Heating Temperature

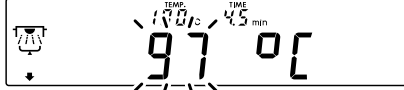
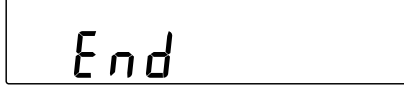
- Place the sensor of the optional temperature adjustment kit (AX-MXA-43) on the tray holder, measure the temperature of the sample tray part, then input the measurement result to the moisture analyzer. This process is performed at 100°C and 160°C.
- Heating is performed at both temperatures for 20 minutes. A buzzer sounds when 20 minutes have elapsed.
- If five minutes elapse without any data input since the buzzer sounded, $t - UP$ is displayed and the process is canceled. Press any key to return to the mass display.
- For information on operating the temperature display, refer to the instruction manual that came with the temperature adjustment kit.

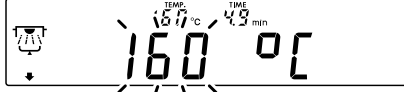
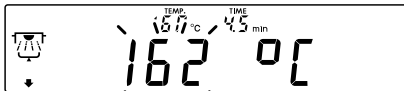

Step	Description	Operation
1.	Connect the sensor of the temperature adjustment kit to the temperature display.	
2.	Press the ON OFF key for the temperature display of the temperature adjustment kit to turn the temperature adjustment kit on.	
3.	Open the heater cover, remove the sample tray, then place the sensor of the temperature adjustment kit on the tray holder.	
4.	Close the heater cover. When doing so, ensure that the wire of the temperature sensor is not pushed by the glass inside the heater unit, as it can cause the sensor of the temperature adjustment kit to lift up. Fold back the cable protruding from the sensor as required.	
5.	Press and hold the PROGRAM key (for approx. two seconds) with the mass displayed to display moisture content measurement check 1 (CHECK 1 <small>MOIST</small>).	

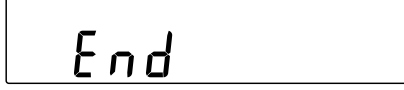
Step	Description	Operation
6.	Press the  or  keys several times to display the heating temperature adjustment (t-CAL).	  
7.	Press the ENTER key to switch to heating temperature adjustment.	  
8.	Press the START key. The moisture analyzer starts temperature control to heat the sample tray to 100°C.	  
9.	When 20 minutes have elapsed, a buzzer sounds, then 100°C flashes. Press the  or  key to change the flashing number until it reaches the actual temperature displayed on the thermometer. (Example: 97°C)	  

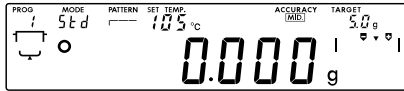
Step	Description	Operation
10.	Press the ENTER key to confirm the value. After displaying <i>End</i> , the moisture analyzer starts temperature control to heat the sample tray to 160°C.	  
11.	When 20 minutes have elapsed, a buzzer sounds, then 160°C flashes. Press the  or  key to change the flashing number until it reaches the actual temperature displayed on the thermometer. (Example: 162°C)	 
12.	Press the ENTER key to confirm the value. After displaying <i>End</i> , the moisture analyzer starts temperature control to heat the sample tray to 160°C.	 
13.	If GLP output is set, a heating temperature adjustment record is output after the operation is finished. (Refer to <i>INF0</i> (GLP output) in <input type="text" value="dout"/> (data output) in "8. Internal Settings".) For information on the output result, refer to "9.3.5. Output for Heating Temperature Adjustment".	 GLP output
14.	The product automatically returns to the mass display.	

8. Internal Settings



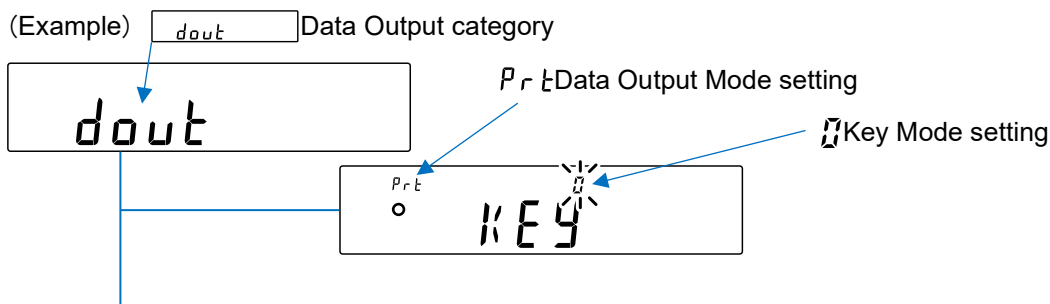

In [8. Internal Settings](#), you can configure and change the operation and communication of the moisture analyzer. The setting values are retained even when the power cable is removed.

The menu in "[8. Internal Settings](#)" is comprised of two levels, categories and settings, and each setting stores a single value. The setting values that are last displayed are enabled. Updated setting values are reflected in the operation of the moisture analyzer after the **ENTER** key is pressed.

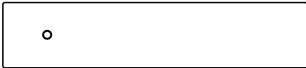

8.1. Procedure

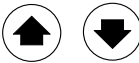









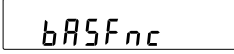

Internal settings display and key operation

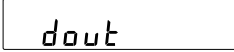

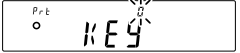

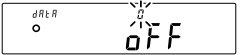

	The  icon is displayed for setting values that are currently enabled.
	Press and hold (for approx. two seconds) with the mass displayed to switch to the internal settings menu. (Display the categories) It changes the category or setting.
	While a setting is displayed, changes the setting value.
	Displays the setting in the category. Registers the setting value, then proceeds to the next category.
	While a setting is displayed, cancels the setting and proceeds to the next category. While a category is displayed, exits the internal settings and returns to the mass display.

Procedure

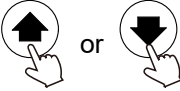
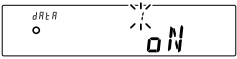
In this example, "the data output mode ($P_{r t}$)" is set to "auto print ($P_{r t} = i$)",

and "the data memory function ($d_{R t A}$)" is set to "oN record measurement results ($d_{R t A} = i$)".

Step	Description	Category	Setting
1.	Press and hold the SELECT key (for approx. two seconds) with the mass displayed to display bR5FnC .	  Press and hold (for approx. two seconds)  Environment/Displa y	
2.	Press the SELECT key several times to change the category to display "dout".	 Press several times  "Data Output"	
3.	Press the ENTER key to switch to the selected category.		 "Data Output Mode" "Key Mode"
4.	Press the   keys to change the value of the selected setting and display "i: Auto".	 or 	 "Data Output Mode" "Auto Print Mode"
5.	Press the SELECT key to change the setting to display "dRtA".		 "Data Memory Function" "oFF"

Step	Description	Category	Setting
6.	<p>To change other settings of the same category, repeat steps 4 and 5.</p> <p>To finish changing the settings of the selected category, proceed to step 7.</p>		 <p>“Data Memory Function” “ON”</p>
7.	<p>To register the setting, Press the ENTER key to display the next category.</p>	  <p>“Serial Interface”</p>	
	<p>To cancel the setting, Press the RESET key to display the next category. The setting value will not be changed.</p>	  <p>“Serial Interface”</p>	
8.	<p>To change the settings of another category, return to step 2. To cancel changing the settings, press the RESET key. The screen returns to the mass display.</p>	 	

8.2. List of Items

Category	Setting	Set value	Description/purpose	
<div style="border: 1px solid black; padding: 2px; display: inline-block;">bASFunc</div> (Basic Function) Environment/ display	<i>Pnt</i> (Point) Decimal point	■ <i>0</i> . Period <i>,</i> Comma	The symbol to display/output for the decimal point.	
	<div style="border: 1px solid black; padding: 2px; display: inline-block;">LED</div> (Display LED) Backlight brightness	<i>0</i> <i>9</i> ■ <i>7</i> 80% by default		10% to 100%
	<i>P-off</i> (Power Off) Auto power off	■ <i>0</i> Off <i>1</i> On (10 minutes)	The display automatically turns off if no operations are performed for 10 minutes.	
	<div style="border: 1px solid black; padding: 2px; display: inline-block;">CALC-Data</div> (Calculation Data) Calculation data	■ <i>0</i> <i>int</i> : Perform calculations with priority given to the accuracy of the moisture content. The moisture content is calculated with more digits than the displayed mass. <i>DISPLAY</i> : The moisture content is calculated with the number of digits for the displayed mass.		
	<div style="border: 1px solid black; padding: 2px; display: inline-block;">CL Adj</div> (Clock Adjustment) Clock	Refer to " 8.4. Checking and Configuring the Date/Time ".		Checks and adjusts the date and time. The date and time are used for output.
	<div style="border: 1px solid black; padding: 2px; display: inline-block;">Prog Func</div> (Program Function) Additional functions for measurement conditions	<div style="border: 1px solid black; padding: 2px; display: inline-block;">CP</div> (Comparator) Comparator mode	■ <i>0</i> <i>OFF</i> : Do not use the comparator function. <i>1</i> <i>ON</i> : Use the comparator function.	
		<div style="border: 1px solid black; padding: 2px; display: inline-block;">OFF SET</div> (Off Set) Moisture content measurement result correction	■ <i>0</i> <i>OFF</i> : Do not use moisture content measurement result correction. <i>1</i> <i>ON</i> : Use moisture content measurement result correction.	

■ indicates a default setting.

Category	Setting	Set value	Description/purpose		
<div style="border: 1px solid black; display: inline-block; padding: 2px;">dout</div> (Data out) Data output	<i>Prt</i> (Print) Data output mode <small>*1</small>	■ 0	Key mode	Press the ENTER key to output data.	
		1	Auto print mode	When measurement finishes, the data is automatically printed.	
		2	Stream mode	The data is continuously output during measurement.	
	<i>dMm</i> (Data Memory) Data memory function	■ 0	oFF: Do not record the measurement results.		
		1	oN: Record the measurement results.		
	<i>S-d</i> (Send Data) Sent data	■ 0	Output the measurement results only.		
		1	Output the measurement results and the temperature data.		
	<i>PUSE</i> (Pause) Data output interval	■ 0	Disabled	Select the interval for data output.	
		1	Enabled: Wait 1.6 seconds		
	<div style="border: 1px solid black; display: inline-block; padding: 2px;">inf</div> (Information) GLP output	■ 0	Disabled		
		1	<i>ALL INT</i> : For each measurement result, outputs (prints) device information, measurement conditions, measurement results, and the signature space together. The clock data of the moisture analyzer is used to output the date and time.		
		2	<i>SEP INT</i> : Outputs the measurement results and the device information, measurement conditions, and signature space separately. The clock data of the moisture analyzer is used to output the date and time.		
		3	<i>ALL EXT</i> : For each measurement result, outputs (prints) device information, measurement conditions, measurement results, and the signature space together. The clock data of an external device is used to output the date and time.		
		4	<i>SEP EXT</i> : Outputs the measurement results and the device information, measurement conditions, and signature space separately. The clock data of an external device is used to output the date and time.		
	<div style="border: 1px solid black; display: inline-block; padding: 2px;">usb</div> (USB) USB settings	<i>UFnc</i> (USB Function)	0	<i>QUICK</i> : Quick USB	
■ 1			<i>VCOM</i> : Bidirectional virtual USB COM		
<div style="border: 1px solid black; display: inline-block; padding: 2px;">id</div> (ID) ID number settings	Refer to " 9.2. Configuring the ID Number ".				

Category	Setting	Set value	Description/purpose
<div style="border: 1px solid black; display: inline-block; padding: 2px;">PW</div> (Password) Password function		■ 0	Disabled
		1	Enabled (restrict use of moisture analyzer)
		2	Enabled (moisture measurement is available)
	<div style="border: 1px solid black; display: inline-block; padding: 2px;">ADMIN</div> (Password No.) Password registration	ADMIN	Administrator password entry
		USER 01	User 1 password entry
USER 10		User 10 password entry	
<div style="border: 1px solid black; display: inline-block; padding: 2px;">initFunc</div> (Initialize Function) Initialization function	<div style="border: 1px solid black; display: inline-block; padding: 2px;">[CLR Fnc]</div> (Clear Function) Initialize internal settings	Enables you to restore the default internal settings of the product. Refer to "15.4. Initializing the Settings".	
	<div style="border: 1px solid black; display: inline-block; padding: 2px;">[CLR ALL]</div> (Clear All) Initialize all	Enables you to restore the default settings of the product. Refer to "15.4. Initializing the Settings".	

■ indicates a default setting.

*1 Commands can be used in all modes.

8.3. Description of Environment/Display Settings

Description of *Pnt* (decimal point)

Selects the symbol to display and output for the decimal point.

Description of *LED* (backlight brightness)

Selects the brightness of the LCD backlight.

Description of *P-off* (auto power off)

The display automatically turns off if no operations are performed for a certain period of time (approx. 10 minutes).

If "PW (the password function)" in "*PASSwd* (password)" is set to "enabled (*LOCK* = 1 or 2)", the display automatically turns off and the user is logged out if no operations are performed.

CAUTION

- The display does not turn off during heating.
- The display does not turn off while the result is displayed, but it may turn off when the product returns to the mass display. (If no operations are performed for a certain period of time (approx. 10 minutes) when logged in as the administrator)

Description of *[CALC -]t* (calculation data)

You can select whether to use the internal mass value (with more digits than the displayed mass) to improve the accuracy of calculating the moisture content, or use the number of digits for the displayed mass.

If the internal mass value is used, the accuracy of the moisture content will be higher, but there may be a difference between the measurement result of the moisture analyzer and the moisture content separately calculated from the mass values output after drying and before drying.

8.4. Checking and Configuring the Date/Time

The moisture analyzer contains a date/time function. This mode enables you to check and configure the date and time. If "INF_D (GLP output)" is set to "1: ALL INT" or "2: SEP INT" in "dout" (data output) in "8. Internal Settings", GLP output is performed when outputting the moisture content measurement result and when adjusting the mass sensor sensitivity or adjusting the heating temperature.

If "INF_D (GLP output)" is set to "3: ALL EXT" or "4: SEP EXT", the clock data of an external device is used.

CAUTION

- Do not configure an invalid value (such as a date that does not exist).
- When the backup battery of the clock expires, `rtc PF` will be displayed.

Battery replacement requires a repair at the place of purchase, but functions other than the clock will continue to operate even if the backup battery has expired. The clock function will also operate normally, as long as power is supplied to the moisture analyzer.







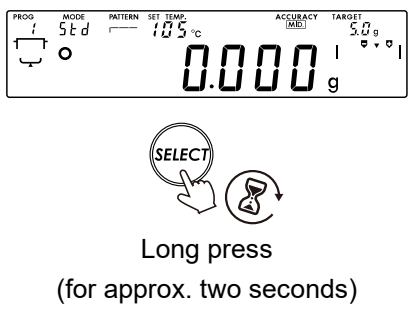
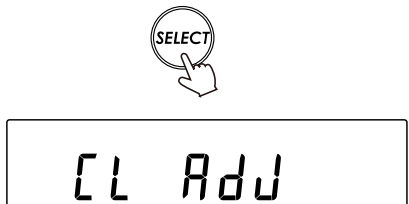
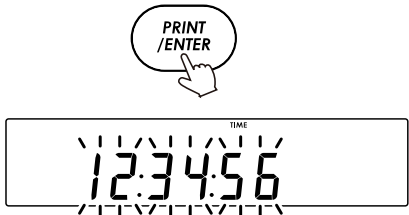

Press the keys to configure the date and time.

You can perform the following operations to check and configure the date and time.

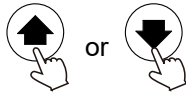

Switching to the Mode for Checking the Date and Time

Step	Description	Display and key operation
1.	Press and hold the <code>SELECT</code> key (for approx. two seconds) with the mass displayed to display the "8. Internal Settings" menu.	 <p>Long press (for approx. two seconds)</p>
2.	Press the <code>SELECT</code> key to match the display with the figure.	
3.	Press the <code>ENTER</code> key to switch to checking the time.	

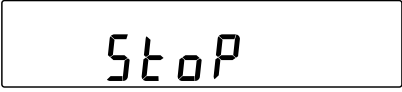
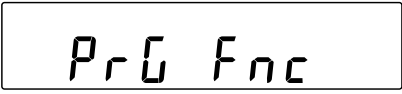



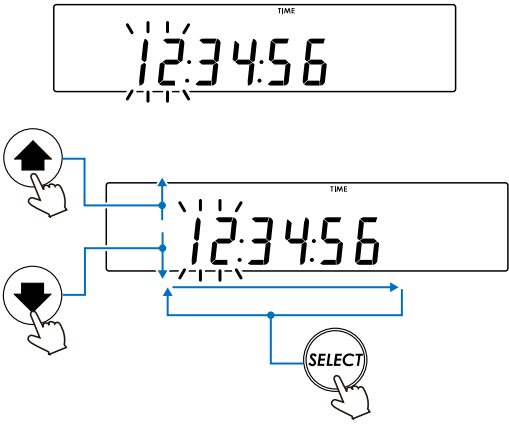
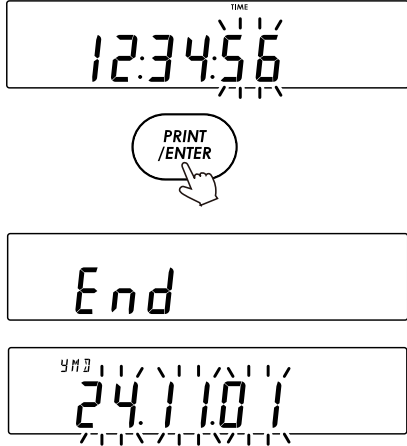

Checking the Time

Step	Description	Display and key operation
4.	<p>The current time is displayed. (All digits flash) The operation branches with keys as follows.</p> <ul style="list-style-type: none"> To change the time, press the  or  key. Proceed to "Configuring the Time" (step 5). To check the time, press the  key. Proceed to "Checking the Date" (step 7). To finish configuring the settings, press the  key. Proceed to "Finishing the Check/Configuration Operation" (step 10). 	<div data-bbox="1023 248 1426 342">  </div> <div data-bbox="1129 376 1315 468">  </div> <div data-bbox="1023 495 1426 589">  </div> <p data-bbox="1023 613 1426 647">Proceed to "Configuring the Time"</p> <div data-bbox="1161 667 1235 759">  </div> <div data-bbox="1023 775 1426 869">  </div> <p data-bbox="1023 896 1426 929">Proceed to "Checking the Date"</p> <div data-bbox="1145 947 1251 1039">  </div> <div data-bbox="1023 1064 1426 1155">  </div> <div data-bbox="1023 1182 1426 1274">  </div> <p data-bbox="1023 1301 1426 1375">Proceed to "Finishing the Check/Configuration Operation"</p>



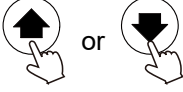
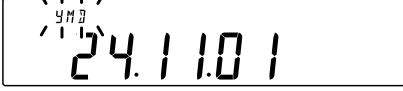

Configuring the Time

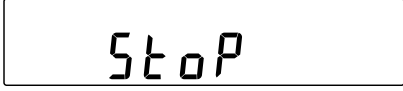
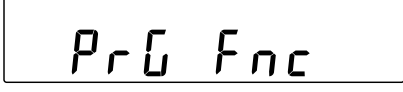
Step	Description	Display and key operation
5.	<p>Press the following keys to configure the time. (In the 24-hour format)</p> <p> key..... Increments the value of the flashing digit (+1).^{*1}</p> <p> key..... Decrements the value of the flashing digit (-1).^{*1}</p> <p>SELECT key.. Moves the cursor.</p> <p>^{*1} Increases or decreases by 30 when changing the number of seconds.</p>	
6.	<p>Press the ENTER key to register the new time. (Press the RESET key to cancel.)</p> <p>Proceed to "Checking the Date" (step 7).</p>	 <p>Proceed to "Checking the Date"</p>

Checking the Date

Step	Description	Display and key operation
7.	The current date is displayed. (All digits flash) The operation branches with keys as follows.	
	<ul style="list-style-type: none"> To change the date, press the  or  key. Proceed to "Configuring the Date" (step 8). 	  Proceed to "Configuring the Date"
	<ul style="list-style-type: none"> To check the time again, press the SELECT key. Proceed to "Checking the Time" (step 4). 	  Proceed to "Checking the Time"
	<ul style="list-style-type: none"> To finish configuring the settings, press the STOP key. Proceed to "Finishing the Check/Configuration Operation" (step 10). 	   Proceed to "Finishing the Check/Configuration Operation"

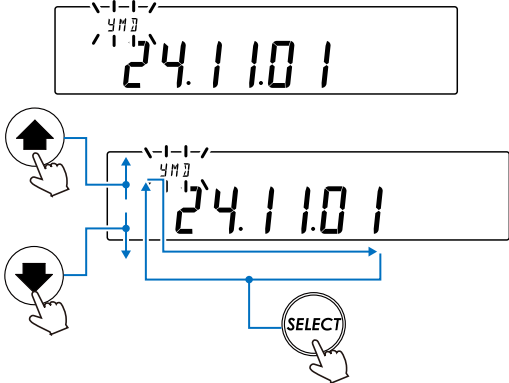
Configuring the Date

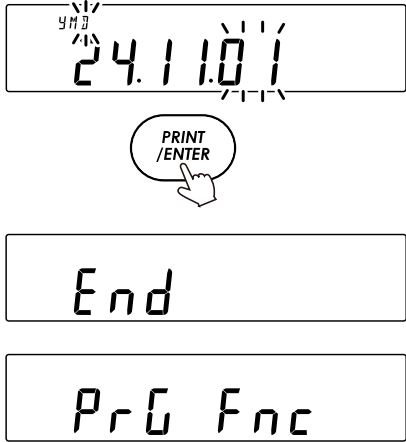
Step	Description	Display and key operation
8.	<p>Press the following keys to configure the date. (For the year, set the last two digits of the Gregorian calendar.)</p> <p> key Increments the value of the flashing number (+1).</p> <p> key Decrements the value of the flashing number (-1).</p> <p> key .. Moves the cursor.</p>	
9.	<p>Press the  key to register the new time. (Press the  key to cancel.)</p> <p>Proceed to "Finishing the Check/Configuration Operation" (step 10).</p>	 <p>Proceed to "Finishing the Check/Configuration Operation"</p>

Finishing the Check/Configuration Operation

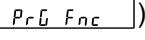
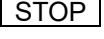
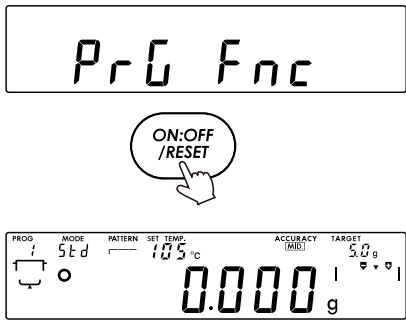
Step	Description	Display and key operation
10.	<p>The next internal setting () is displayed. Press the  key to return to the mass display.</p>	

8.5. Additional Functions for Measurement Conditions

You can enable measurement conditions that are disabled by default.

When a function is enabled, the setting is added to the measurement conditions.

Even if functions are configured in the measurement conditions, they will not operate if they are disabled in the internal settings.

Description of $[P]$ (comparator mode)

If $[P]$ is set, the comparator setting is added to the measurement conditions.

When a moisture content lower limit and upper limit are set, the comparator result of $H \geq L$ is added when displaying the moisture content of measurement results, when performing GLP output for the measurement results, and when saving the measurement results with the data memory function.

If $[P]$ is not set, the comparator setting is not added to the measurement conditions.

(For details, refer to "6.4.10. Comparator Values".)

Description of $[MFC]$ (moisture content measurement result correction)

If $[MFC]$ is set, the correction of measurement results setting is added to the measurement conditions.

The set value is added when displaying/outputting the measured moisture content.

Formula

The displayed moisture content equals the moisture content that is actually measured plus the correction value.

CAUTION

- If the measured value is negative, 0% is displayed for the moisture content.

If $[MFC]$ is not set, correction is not performed.

(For details, refer to "6.4.11. Correction of measurement results".)

8.6. Description of Data Output

8.6.1. Data Output Mode

The timing of the data output can be switched with “ P_{rt} (data output mode)” in “ (data output)” in “8. Internal Settings”.

Key mode

Internal settings $P_{rt} = 0$

You can press the key to output the displayed mass value and moisture content once.

Auto print mode

Internal settings $P_{rt} = 1$

When moisture content measurement finishes, the measurement results are automatically output.

You can also press the key to output the displayed mass value and moisture content once.

Stream mode

Internal settings $P_{rt} = 2$

The data is continuously output during measurement.

You can also press the key while the mass or result is displayed to output the displayed mass value and moisture content once.

8.6.2. Data Format

Format output from the virtual COM (USB) and RS-232C: Standard A&D format

(S-d = 0 and LF = 0 in the internal settings)

- Each item of data includes 15 characters. (Not including the terminator)
- The state of the data is indicated in two headers.
- The data is signed and is zero-padded (leading spaces are filled with zeros).
- When the data is zero, it is deemed positive.
- Each item of data includes 3 characters.

CR 0Dh Carriage return
LF 0Ah Line feed
_ 20h Space

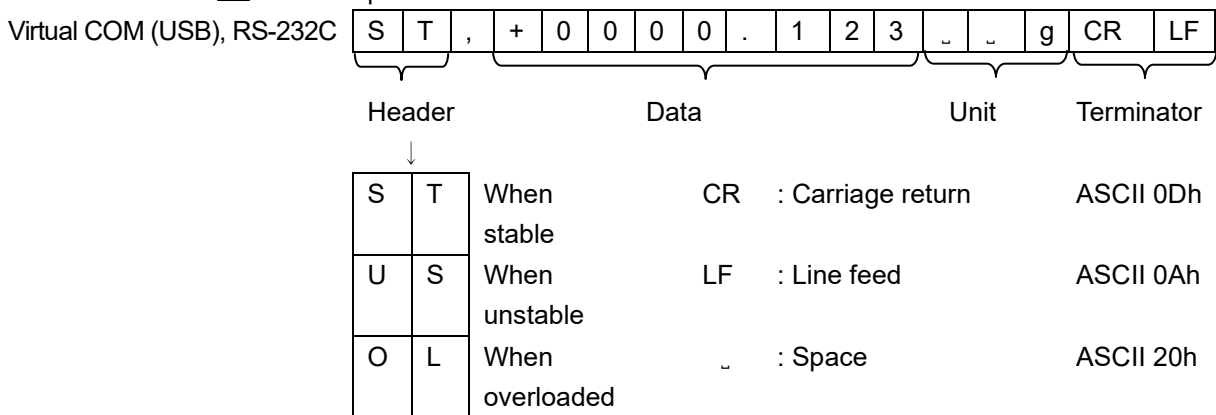

Format output with quick USB: NU2 format

(S-d = 0 and LF = 0 in the internal settings)

- Only values are output.
- When the data is zero or a positive value, it is not signed.

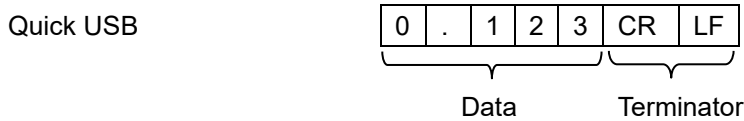

8.6.3. Example Output for Data Format

Sample mass value (data format output when performing measurement with the mass display or "g" for the unit)

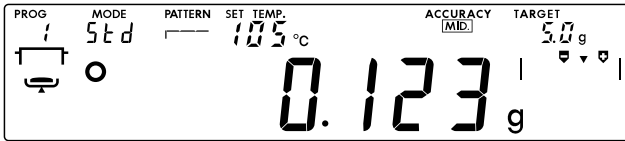

A&D	S	T	,	+	0	0	0	0	.	1	2	3	g	CR	LF	
NU2	0	.	1	2	3	CR	LF									

When over (positive)

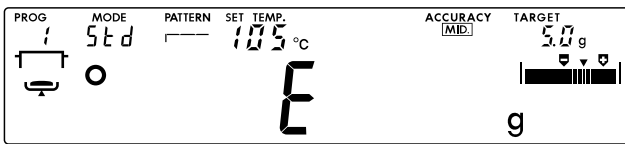

A&D	O	L	,	+	9	9	9	9	9	9	9	E	+	1	9	CR	LF	
NU2	+	9	9	9	9	9	9	9	9	CR	LF							

When over (negative)

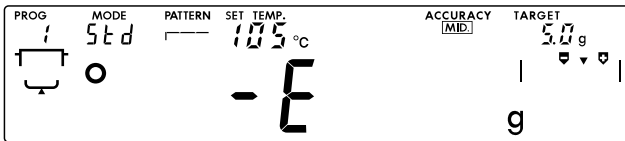

A&D	O	L	,	-	9	9	9	9	9	9	9	E	+	1	9	CR	LF	
NU2	-	9	9	9	9	9	9	9	9	CR	LF							

Moisture content (data format output during measurement or after measurement is finished)

- * The position of the decimal point in the data depends on the model and the minimum displayed.
(S-d = 0 and INF0 = 0 in the internal settings)

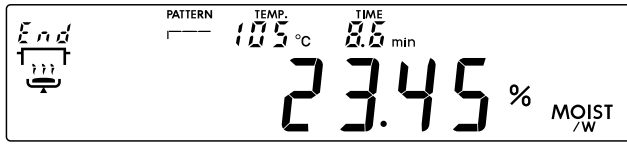

A&D	S	T	,	+	0	0	0	2	3	.	4	5	_	_	%	CR	LF
NU2	2	3	.	4	5	CR	LF										

When adding temperature data to the moisture content data

- (S-d = ! and INF0 = 0 in the internal settings)

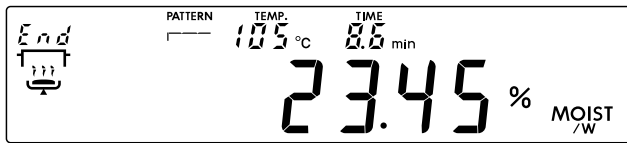

A&D	1	0	5	,	S	T	,	+	0	0	0	2	3	.	4	5	_	_	%	CR	LF
NU2	1	0	5	TAB	2	3	.	4	5	CR	LF										

TAB: Horizontal tab, ASCII 09h

9. GLP and ID Numbers

9.1. Main Uses

By setting "iNFo (GLP output)" to 1 to 4 in dOUt (data output) in "8. Internal Settings", data supporting GLP/GMP can be output from the moisture analyzer to a printer or computer.

GLP refers to "Good Laboratory Practice".

GMP refers to "Good Manufacturing Practice".

The data output supporting GLP or GMP includes the moisture analyzer manufacturer name (A&D), model name, serial number, ID number, date, time, and signature. Mass sensor sensitivity adjustment includes the weight used, and heating temperature adjustment includes the set temperature.

The following data supporting GLP or GMP can be output from the RS-232C or USB terminal.

- Record of mass sensor sensitivity adjustment
(output when sensitivity adjustment is performed with a weight you have)
- Heating temperature adjustment
(output when heating temperature adjustment is performed with the temperature adjustment kit)
 - The ID number can be used as the moisture analyzer identification number for maintenance management.
 - The ID number is retained even when the power is turned off and is enabled until a new number is registered.
 - For information on checking/adjusting the date and time, refer to "8.4. Checking and Configuring the Date/Time".
 - When connecting the AD-8127 (multi printer) or AD-8129TH (thermal printer) to the moisture analyzer to print the GLP output, the clock function of the printer can be used to print the date and time.
 - (dout iNFo = 3 or 4 in 8. Internal Settings)
Useful for the centralized management of date/time modification prevention using the password function of the AD-8127 or AD-8129TH.

ADVICE

- When outputting data supporting GLP/GMP, set the print mode of the AD-8127 or AD-8129TH to the dump print mode (DUMP). If the external key print mode (EXT.KEY) was used to print the mass value and moisture content, you can press and hold (for approx. two seconds) the  button of the AD-8127 or AD-8129TH to switch between the external print mode and dump print mode.

9.2. Configuring the ID Number

Display Correspondence Table

Refer to the following table to identify the segment display corresponding to each character.









0	1	2	3	4	5	6	7	8	9	-	_	A	B	C	D	E	F	G	H	I	J	K	L	M	N	O	P	Q	R	S	T	U	V	W	X	Y	Z
0	1	2	3	4	5	6	7	8	9	-	_	A	B	C	D	E	F	G	H	I	J	K	L	M	N	O	P	Q	R	S	T	U	V	W	X	Y	Z

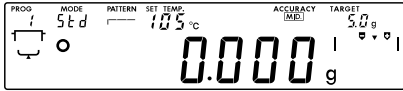



←  key

Space

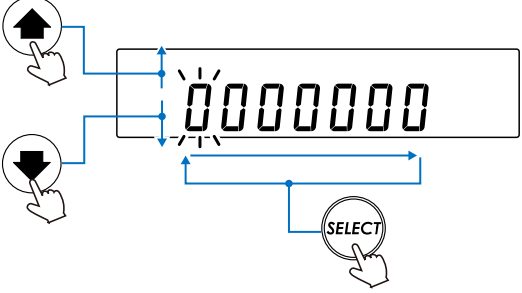
 key →

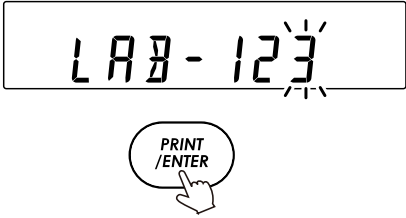
Setting Method (Changing the Internal Settings)

Step	Description	Display and key operation
1.	Press and hold the SELECT key (for approx. two seconds) with the mass displayed to display the "8. Internal Settings" menu.	  Long press (for approx. two seconds) 
2.	Press the SELECT key several times to match the display with the figure.	 Press several times 
3.	Press the ENTER key to input the ID number using the following keys. SELECT key Moves the flashing digit.  key Changes the character of the flashing digit. (+)  key Changes the character of the flashing digit. (-)	 

Step	Description	Display and key operation
4.	Press the ENTER key to register the change. (Press the RESET key to cancel without registering the changes.)	  
5.	Press the RESET key to return to the mass display.	 

9.3. GLP output

To output data supporting GLP or GMP to the AD-8127 (multi printer), AD-8129TH (thermal printer), or a computer, set "INF" (GLP output) to "1" to "4" in "dout" (data output) in "8. Internal Settings".

The differences between each setting are as follows.

INF setting	Measurement result output ^{*1}	Clock data
1: ALL INT	Output all	Use internal data
2: SEP INT	Output separately	Use internal data
3: ALL EXT	Output all	Use external device data
4: SEP EXT	Output separately	Use external device data

*1 Measurement result output

Output all: Outputs the "device information", "measurement conditions", and "signature space" together with the measurement results.

Output separately: Outputs the "device information", "measurement conditions", and "signature space" separately from the measurement results.









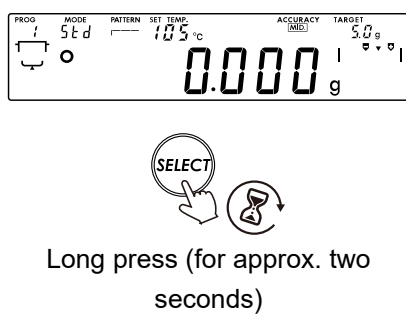
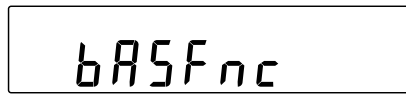





If you want to manage clock data with the clock function of an external device, it is convenient to set this to "3: ALL EXT" or "4: SEP EXT".

CAUTION

- If the date/time does not match when outputting the clock data in the moisture analyzer (INF = 1 or 2), adjust the time/date using "CL Adj" (time) in "8. Internal Settings". 
- Clock data output using an external device is only supported for devices with a clock function that can output the date/time by receiving <ESC>D and <ESC>T. ^{*1}
(AD-8127, AD-8129TH, and RsCom data communication software of WinCT, etc.)
^{*1} <ESC> refers to the escape code (ASCII 1Bh).
- The clock data saved with the data memory function is always the internal data. External device data cannot be used.
- When outputting to a printer, set the AD-8127 or AD-8129TH (multi printer) to the dump print mode (DUMP).

Setting Method (Changing the Internal Settings)

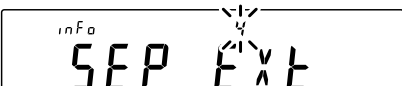
Step	Description	Display and key operation
1.	Press and hold the SELECT key (for approx. two seconds) with the mass displayed to display the "8. Internal Settings" menu.	 <p>Long press (for approx. two seconds)</p> 

Step	Description	Display and key operation
2.	Press the SELECT key several times to match the display with the figure.	 <p>Press several times</p> 
3.	Press the ENTER key.	 
4.	Press the SELECT key several times to display <i>info</i> (GLP output).	 
5.	Press the  and  keys several times to change " <i>info</i> (GLP output)" to "1: ALL <i>info</i> ", "2: SEP <i>info</i> ", "3: ALL EXT", or "4: SEP EXT".	  <p>Press several times</p>    
6.	Press the ENTER key to register the change.	 

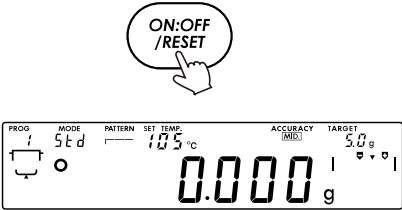
Step	Description	Display and key operation
7.	Press the RESET key to return to the mass display.	

9.3.1. Example Measurement Result Output

Example with All Data Output

This method outputs the measurement results together with the device information, measurement conditions, measurement data, and signature space.

Refer to "8. Internal Settings" to set " *INF* " (GLP output)" to " *1: ALL INT* " or " *3: ALL EXT* ".

Example Output (1)

When "8. Internal Settings" - "INF d(GLP output)" is set to " : ALL ,NE"

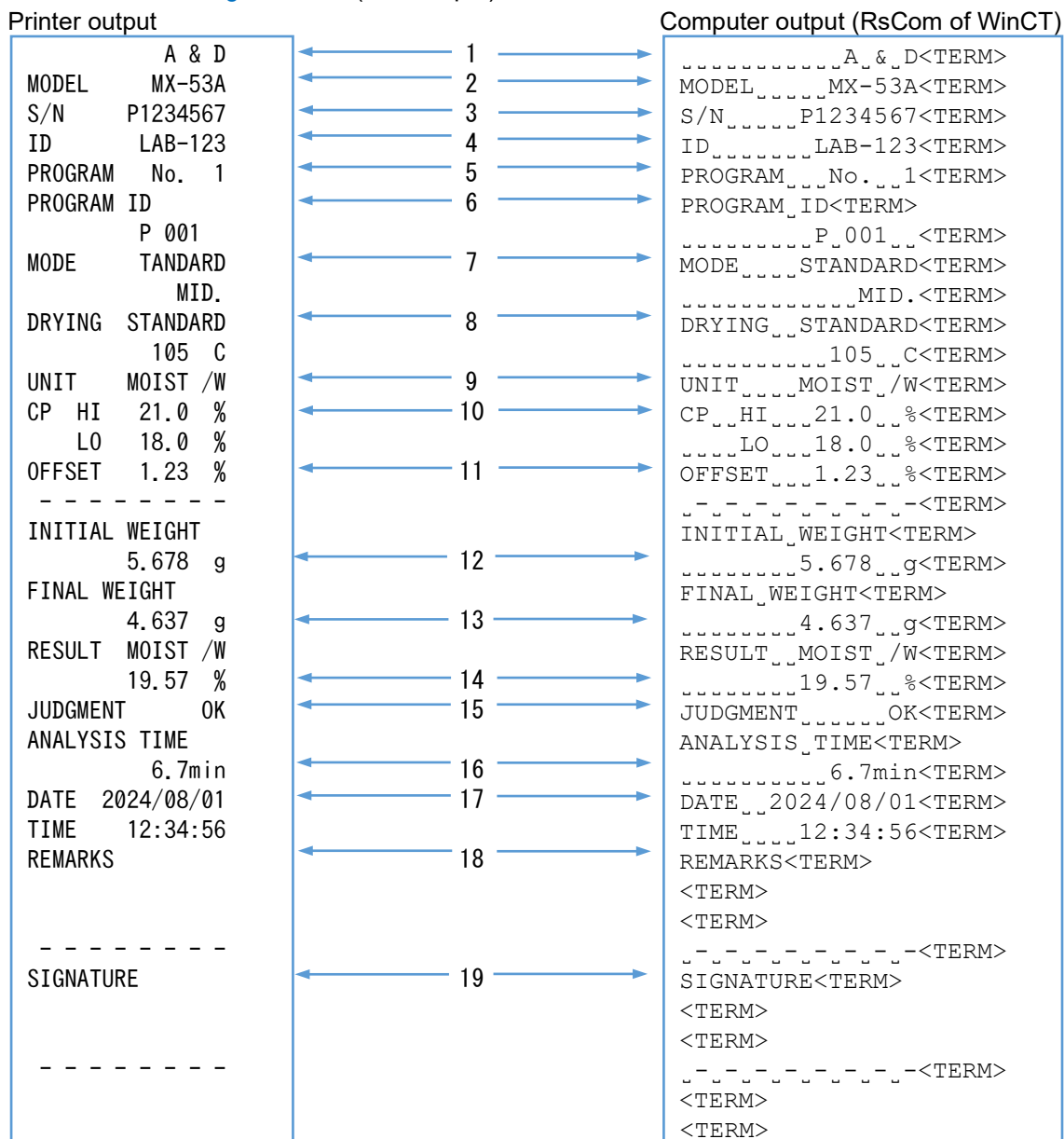

_ : Space: ASCII 20h
 <TERM> : Terminator: CR LF
 CR : Carriage return: ASCII 0Dh
 LF : Line feed: ASCII 0Ah

- | | | | | | |
|---|--------------------------------|----|---|----|---------------------------------|
| 1 | Manufacturer name | 8 | Heating pattern ^{*1} | 15 | Comparator result ^{*3} |
| 2 | Model name | 9 | Measurement basis | 16 | Measurement time ^{*1} |
| 3 | Serial number | 10 | Comparator setting ^{*3} | 17 | Measurement date/time |
| 4 | ID | 11 | Correction of measurement results ^{*2} | 18 | Remarks space ^{*1} |
| 5 | Program number | 12 | Sample mass before drying | 19 | Signature space ^{*1} |
| 6 | Program ID | 13 | Sample mass after drying | | |
| 7 | Measurement mode ^{*1} | 14 | Measurement result | | |

^{*1} Refer to "9.3.2. Description of Printed Information"

^{*2} Only printed when correction of measurement results is enabled and the setting value is not 0%

^{*3} Only printed when the comparator function is enabled and either the upper limit or lower limit is set to a value other than 0%

Example Output (2)

When "8. Internal Settings" - "INFd (GLP output)" is set to "3 : ALL EXE"

Printer output		Computer output (RsCom of WinCT)
A & D	1A_&_D<TERM>
MODEL MX-53A	2	MODEL.....MX-53A<TERM>
S/N P1234567	3	S/N.....P1234567<TERM>
ID LAB-123	4	ID.....LAB-123<TERM>
PROGRAM No. 1	5	PROGRAM...No...1<TERM>
PROGRAM ID	6	PROGRAM_ID<TERM>
P 001	P_001...<TERM>
MODE STANDARD	7	MODE.....STANDARD<TERM>
MID.	MID.<TERM>
DRYING STANDARD	8	DRYING...STANDARD<TERM>
105 C	105...C<TERM>
UNIT MOIST /W	9	UNIT...MOIST_/W<TERM>
CP HI 21.0 %	10	CP_HI...21.0...%<TERM>
LO 18.0 %	LO...18.0...%<TERM>
OFFSET 1.23 %	11	OFFSET...1.23...%<TERM>
-----	<TERM>
INITIAL WEIGHT		INITIAL_WEIGHT<TERM>
5.678 g	125.678...g<TERM>
FINAL WEIGHT		FINAL_WEIGHT<TERM>
4.637 g	134.637...g<TERM>
RESULT MOIST /W		RESULT...MOIST_/W<TERM>
19.57 %	1419.57...%<TERM>
JUDGMENT OK	15	JUDGMENT.....OK<TERM>
ANALYSIS TIME		ANALYSIS_TIME<TERM>
6.7min	166.7min<TERM>
DATE 2024/08/01	17	2024-08-01<TERM> *1
TIME 12:34:56		12:34:56<TERM>
REMARKS	18	REMARKS<TERM>
		<TERM>
		<TERM>
-----	<TERM>
SIGNATURE	19	SIGNATURE<TERM>
		<TERM>
		<TERM>
-----	<TERM>
		<TERM>
		<TERM>

_ : Space: ASCII 20h
 <TERM> : Terminator: CR LF
 CR : Carriage return: ASCII 0Dh
 LF : Line feed: ASCII 0Ah

- | | | |
|----------------------|--|--------------------------|
| 1 Manufacturer name | 8 Heating pattern*2 | 15 Comparator result*4 |
| 2 Model name | 9 Measurement basis | 16 Measurement time*2 |
| 3 Serial number | 10 Comparator setting*4 | 17 Measurement date/time |
| 4 ID | 11 Correction of measurement results*3 | 18 Remarks space*2 |
| 5 Program number | 12 Sample mass before drying | 19 Signature space*2 |
| 6 Program ID | 13 Sample mass after drying | |
| 7 Measurement mode*2 | 14 Measurement result | |

*1 The order and notation used for the year, month, and day depend on the version of WinCT and the configuration of the computer.

*2 Refer to "9.3.2. Description of Printed Information"

*3 Only printed when correction of measurement results is enabled and the setting value is not 0%

*4 Only printed when the comparator function is enabled and either the upper limit or lower limit is set to a value other than 0%









When Outputting Data Separately

In this example, the device information, measurement conditions, and signature space are printed at a different time to the measurement data.

This enables you to save paper when the measurement conditions are the same.

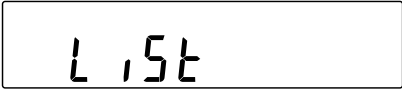
Refer to "8. Internal Settings" to set " *INF* (GLP output)" to " *2 : SEP INT*" or " *4 : SEP EXT*".

How to Print the Device Information and Measurement conditions









Step	Description	Display and key operation
1.	Press and hold the ENTER key with the mass displayed.	  Long press (for approx. two seconds)  or 
2.	Press the SELECT key to display <i>L 15t</i> . When the data memory function is enabled (when " <i>DATA</i> (data memory function)" is set to " <i>I</i> "), <i>OUT</i> and <i>CLR</i> are also displayed.	 
3.	Press the ENTER key to output the "device information" and "measurement conditions". When the output is complete, the product automatically returns to the mass display.	  "Device information" and "measurement conditions" output 

How to Print the Measurement Data

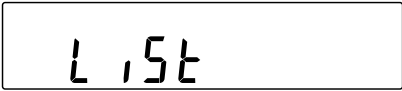
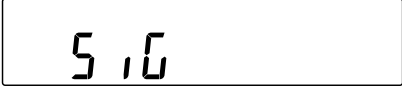
The method for printing the data depends on the internal settings of the moisture analyzer. (For details, refer to "8.6.1. Data Output Mode".)

Print setting	Output method
0	Press the ENTER key with the measurement result displayed.
1	When measurement finishes, the "measurement data" is automatically printed.
2	Press the ENTER key with the measurement result displayed. (This method is not appropriate for outputting only the "measurement data" while heating, because the moisture content will be continuously output.)

How to Print the Signature Space

Step	Description	Display and key operation
1.	Press and hold the ENTER key with the mass displayed.	  Long press (for approx. two seconds)  or 
2.	Press the SELECT key to display 5.10. * When the data memory function is enabled (when "dAtA (data memory function)" is set to "1"), out and CLR are also displayed.	 
3.	Press the ENTER key to output the "signature space". When the output is complete, the product automatically returns to the mass display.	   "Signature space" output 

Example Output

When "INF0 (GLP output)" in "8. Internal Settings" is set to "2 : SEP INL"

Printer output

Computer output (RsCom of WinCT)

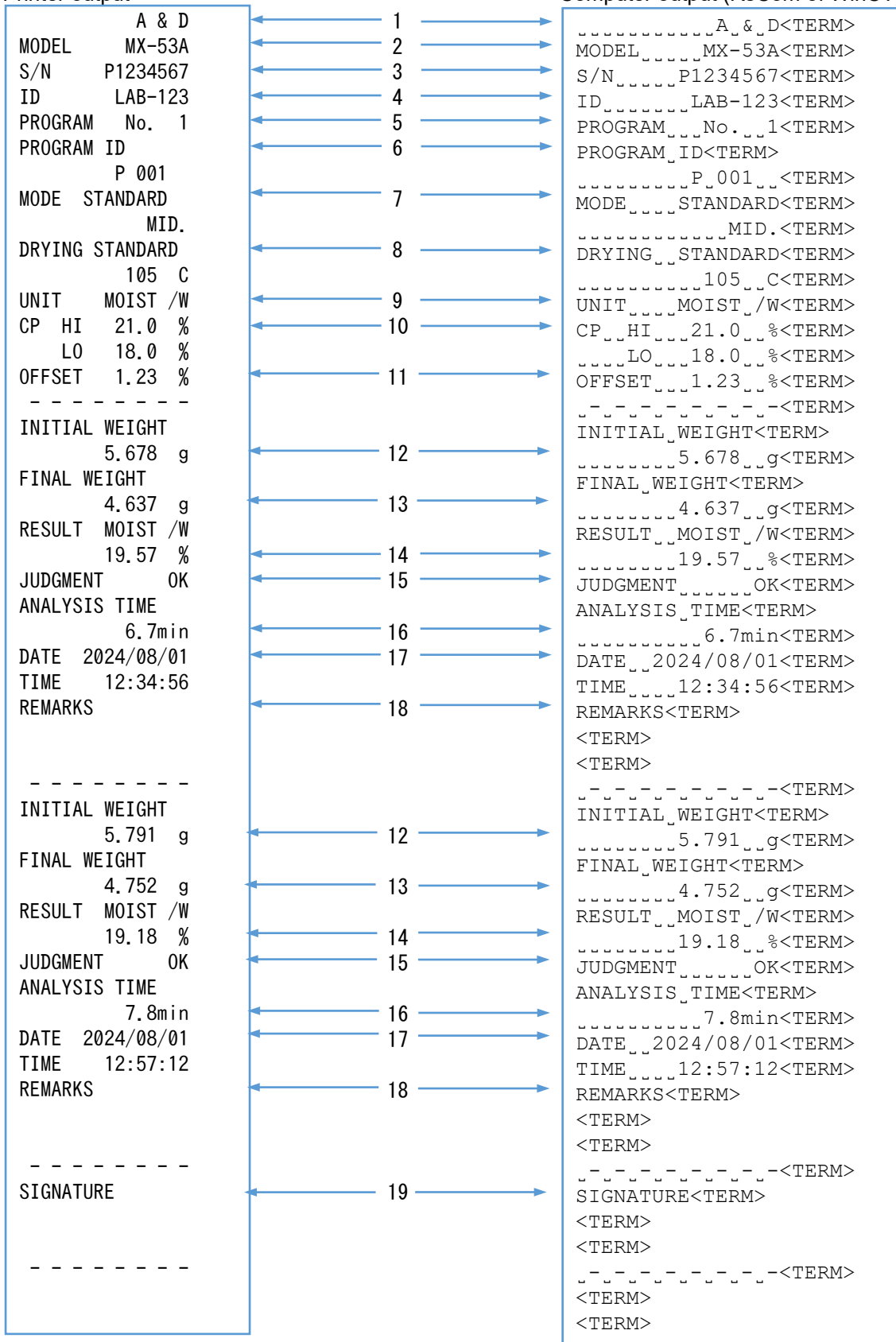

_ : Space: ASCII 20h
 <TERM> : Terminator: C_R L_F
 C_R : Carriage return: ASCII 0Dh
 L_F : Line feed: ASCII 0Ah

1	Manufacturer name	8	Heating pattern ^{*1}	15	Comparator result ^{*3}
2	Model name	9	Measurement basis	16	Measurement time ^{*1}
3	Serial number	10	Comparator setting ^{*3}	17	Measurement date/time
4	ID	11	Correction of measurement results ^{*2}	18	Remarks space ^{*1}
5	Program number	12	Sample mass before drying	19	Signature space ^{*1}
6	Program ID	13	Sample mass after drying		
7	Measurement mode ^{*1}	14	Measurement result		

^{*1} Refer to "9.3.2. Description of Printed Information"

^{*2} Only printed when correction of measurement results is enabled and the setting value is not 0%





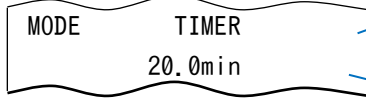
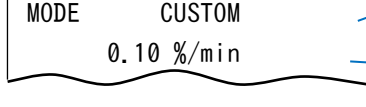

^{*3} Only printed when the comparator function is enabled and either the upper limit or lower limit is set to a value other than 0%

9.3.2. Description of Printed Information

Measurement Mode, Measurement Conditions

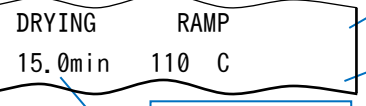
Measurement mode	Printed part and description
Standard mode <i>Std</i>	 <p>Standard mode</p> <p>Measurement accuracy setting: ACCURACY</p>
Timer mode <i>TIME</i>	 <p>Timer mode</p> <p>Measurement time</p>
Custom mode <i>CSTM</i>	 <p>Custom mode</p> <p>Termination value</p>

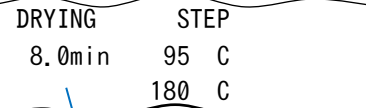
Heating Pattern

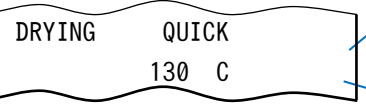
Heating pattern	Printed part and description
Standard drying 	 <p>Standard heating</p> <p>Sample tray temperature</p>
Slow heating 	 <p>Slow heating</p> <p>Target sample tray temperature</p> <p>Time step 1</p>
Step heating 	 <p>Step heating</p> <p>Sample tray temperature step 1</p> <p>Sample tray temperature step 2</p> <p>Time step 1</p>
Rapid heating 	 <p>Rapid heating</p> <p>Sample tray temperature</p>

Comparator

This is only printed when the "comparator mode (CP)" in "8. Internal Settings" is set to "ON : CP = 1" and either the upper limit or lower limit is set to a value other than 0%.

Item		Printed part and description	
Set value			Comparator setting upper limit value Comparator setting lower limit value
Result	Result when upper limit value is less than moisture content		Comparator result
	Result when lower limit value is less than or equal to moisture content result and moisture content result is less than or equal to upper limit value		Comparator result
	Result when moisture content result is less than lower limit value		Comparator result

Result Correction

The correction value adding when calculating the final measurement result from the moisture content measurement result.

Only printed when "moisture content measurement result correction (OFFSET)" is set to "ON : OFFSET = 1" in "8. Internal Settings" and the correction value is not 0%.

--

Measurement basis

Measurement Basis	Printed part	Formula of displayed value	Display
Moisture content (standard before drying) ^{*1}		$\frac{W - D}{W} \times 100$	% MOIST /W
Moisture content (Atro) (standard after drying) ^{*2}		$\frac{W - D}{D} \times 100$	% MOIST /D
Solids		$\frac{D}{W} \times 100$	% RATIO D/W
Ratio ^{*2}		$\frac{W}{D} \times 100$	% RATIO W/D
Grams		— ^{*3}	g

W: Sample mass before drying D: Sample mass after drying

*1 Default setting

*2 If the sample mass decreases after drying and the measured value exceeds 999%, operation automatically stops because the measurement results cannot be calculated correctly.

*3 The moisture content result is derived from the moisture content (standard before drying).

Measurement Date/Time

The measurement date/time outputs the date/time of the clock in the moisture analyzer.

The date order (YYYYMMDD, MMDDYYYY, or DDMMYYYY) follows the setting in ["8.4. Checking and Configuring the Date/Time"](#).

For information on adjusting the clock, refer to ["8.4. Checking and Configuring the Date/Time"](#).

DATE	2003/08/01
TIME	13:24:57

Remarks Space

Enables you to enter a comment such as the name of the measured sample.

REMARKS

Signature Space

Enables you to write your signature.

SIGNATURE

9.3.3. Test Sample Output for Function Check

The GLP output when performing a function check with a test sample is indicated below.

Example Output

When "8. Internal Settings" - "inFd(GLP output)" is set to "1 : ALL INE"

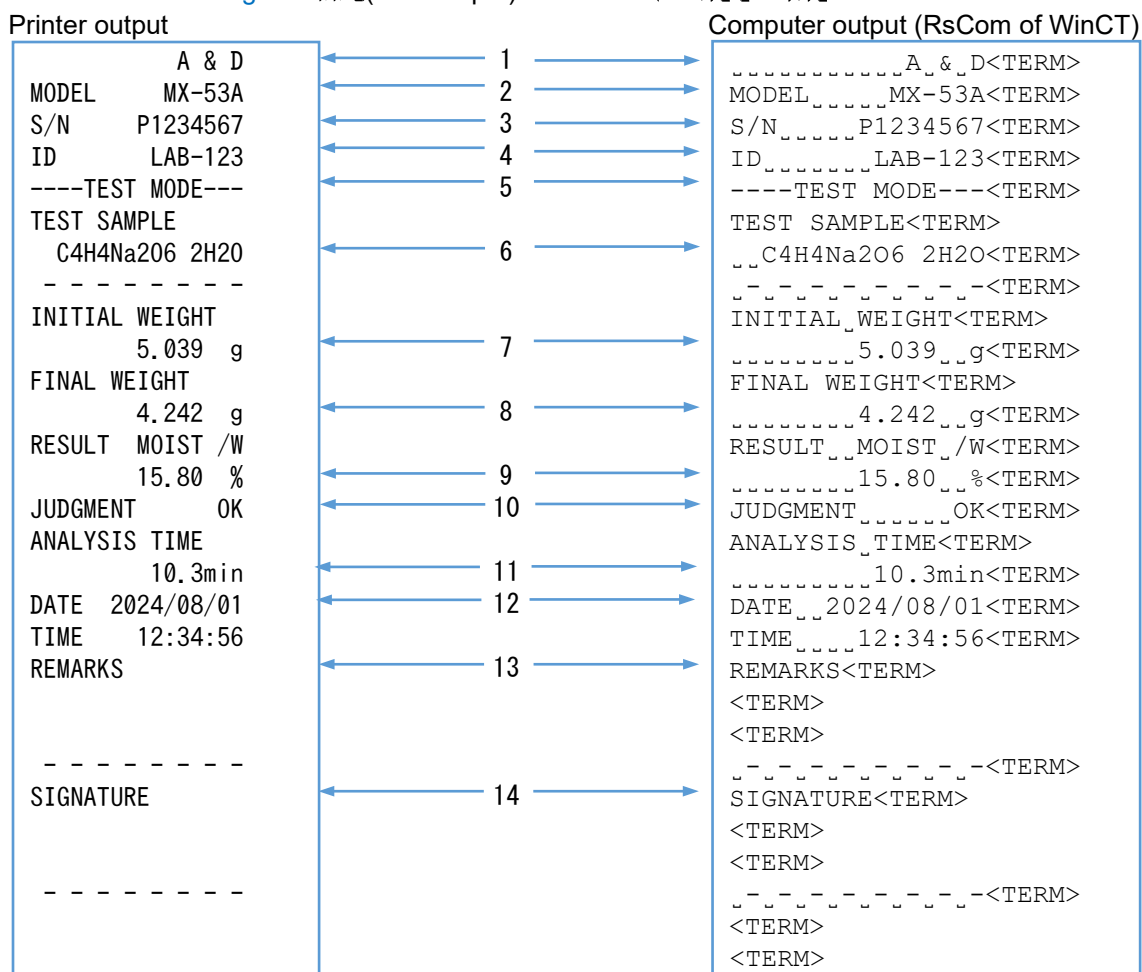

_ : Space: ASCII 20h
 <TERM> : Terminator: C_R L_F
 C_R : Carriage return: ASCII 0Dh
 L_F : Line feed: ASCII 0Ah

- | | | |
|---|-----------------------------------|----------------------------------|
| 1 Manufacturer name | 7 Sample mass before drying | 13 Remarks space ^{*1} |
| 2 Model name | 8 Sample mass after drying | 14 Signature space ^{*1} |
| 3 Serial number | 9 Measurement result | |
| 4 ID | 10 Comparator result | |
| 5 Test mode | 11 Measurement time ^{*1} | |
| 6 Test sample name
(sodium tartrate) | 12 Measurement date/time | |

^{*1} Refer to "9.3.2. Description of Printed Information"

9.3.4. Mass Sensor Output for Sensitivity Adjustment

The GLP output when performing sensitivity adjustment of the mass sensor is indicated below.

Example Output (1)

When "8. Internal Settings" - "inFd(GLP output)" is set to " : ALL INE"

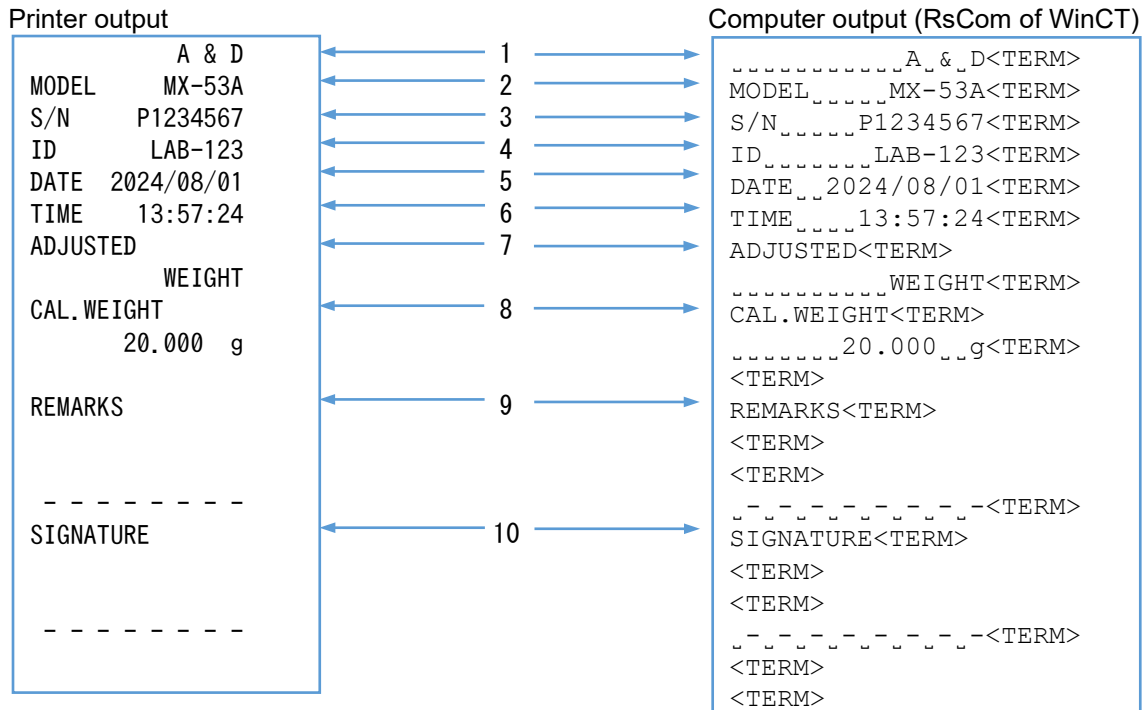

_ : Space: ASCII 20h
 <TERM> : Terminator: CR LF
 CR : Carriage return: ASCII 0Dh
 LF : Line feed: ASCII 0Ah

- | | | | |
|---|-------------------|----|--------------------------------------|
| 1 | Manufacturer name | 7 | Sensitivity adjustment (mass sensor) |
| 2 | Model name | 8 | Weight value |
| 3 | Serial number | 9 | Remarks space*1 |
| 4 | ID | 10 | Signature space*1 |
| 5 | Date | | |
| 6 | Time | | |

*1 Refer to "9.3.2. Description of Printed Information"

9.3.5. Output for Heating Temperature Adjustment

The GLP output when performing adjustment of the heating temperature is indicated below.

Example Output

When "8. Internal Settings" - "inFd(GLP output)" is set to " : ALL INE"

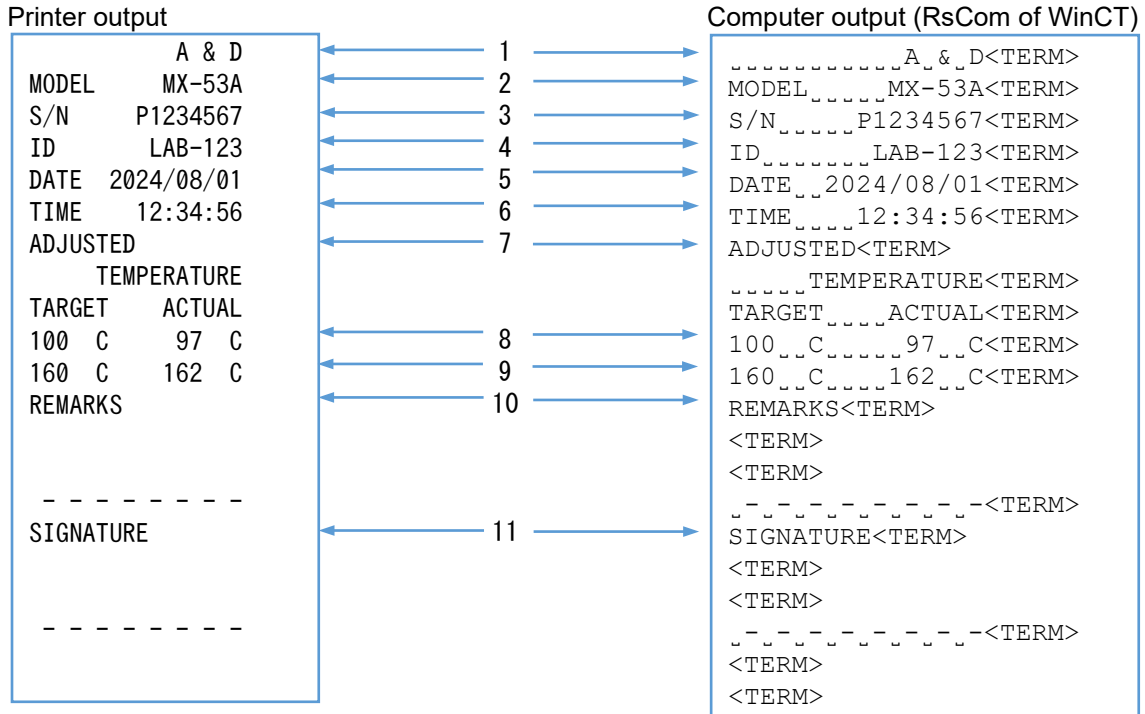

_ : Space: ASCII 20h
 <TERM> : Terminator: CR LF
 CR : Carriage return: ASCII 0Dh
 LF : Line feed: ASCII 0Ah

- | | | | |
|---|-------------------|----|--|
| 1 | Manufacturer name | 7 | Sensitivity adjustment (heating temperature) |
| 2 | Model name | 8 | Target temperature: 100°C Actual temperature (corrected input temperature) |
| 3 | Serial number | 9 | Target temperature: 160°C Actual temperature (corrected input temperature) |
| 4 | ID | 10 | Remarks space*1 |
| 5 | Date | 11 | Signature space*1 |
| 6 | Time | | |

*1 Refer to "9.3.2. Description of Printed Information"

10. Data Memory Function

- The data memory function automatically records the measurement results when measurement is complete.
- Up to 200 sets of data can be recorded.
- The recorded measurement results can be output to the AD-8127 (multi printer) or AD-8129TH (thermal printer) or imported to a computer using the communication software (WinCT).
- The recorded measurement results can also be erased.
- You can select either “ \uparrow (record)” or “ \downarrow (do not record)” for the “data memory function (dAtA)” in “8. Internal Settings”.
- **MEM** is displayed when the data memory function is enabled.
- If **FUL** is displayed, new results cannot be recorded unless existing results are erased.
- To record measurement results, make sure to enable the data memory function before performing measurement.

CAUTION



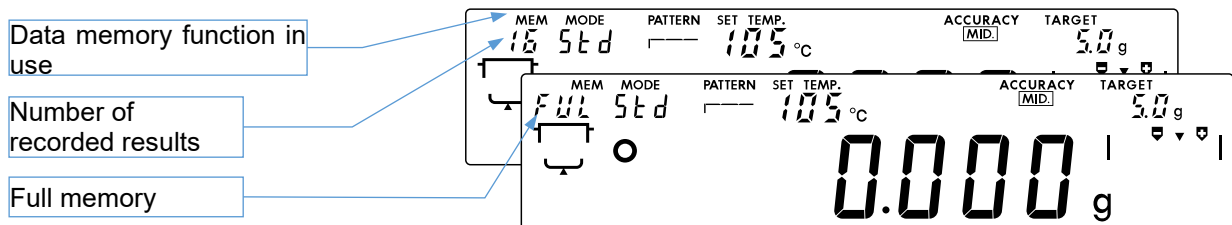





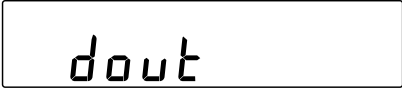

- If the data memory function is used to display the mass, the data number (**MEM**) is prioritized over the program number (**PROG**).

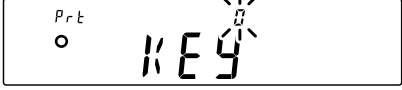

10.1. Preparations

Enabling the Data Memory Function (Changing the Internal Settings)

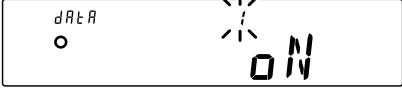





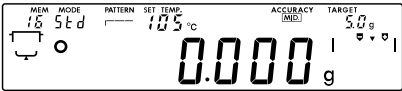

Step	Description	Display and key operation
1.	Press and hold the SELECT key (for approx. two seconds) with the mass displayed to display the "8. Internal Settings" menu.	<p>The scale display shows '0.000 g' and 'bASFnC'. A hand icon is shown pressing the 'SELECT' key, with a circular arrow indicating a long press.</p> <p>Long press (for approx. two seconds)</p>

Step	Description	Display and key operation
2.	Press the SELECT key several times to match the display with the figure.	 <p>Press several times</p> 
3.	Press the ENTER key.	 
4.	Press the SELECT key to display the "dAtA" (data memory function)" item.	 
5.	Press the  or  key to set "dAtA (data memory function)" to "I (enabled)".	  
6.	Press the ENTER key to register the change.	 

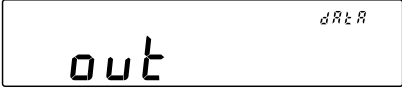
10.2. Batch Output of Recorded Results

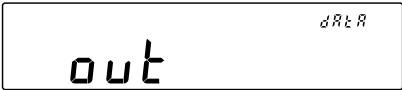
CAUTION

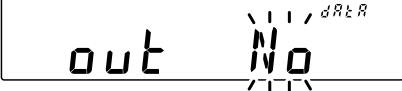
- With the default internal settings, the “data output interval (*PULSE*)” is set to “no interval (*PULSE* = 0)”. If the printer set as the output destination requires an interval, refer to “8. Internal Settings” to change to “about a 1.6 second interval (*PULSE* = 1)”.

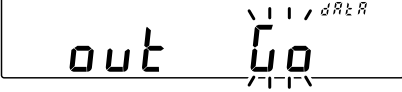
Step	Description	Display and key operation
1.	Press and hold the ENTER key (for approx. two seconds) with the mass displayed.	  Long press (for approx. two seconds) 
2.	Press the SELECT key several times to display <i>out</i> , as required. *When GLP output is enabled (when " <i>INF0</i> (GLP output)" is set to "2" or "4"), <i>L 15t</i> and <i>S 1U</i> are also displayed.	 Press several times 
3.	Press the ENTER key. *If the measurement result has not been saved, <i>No dAtA R</i> is displayed.	  
4.	Press the SELECT key.	  

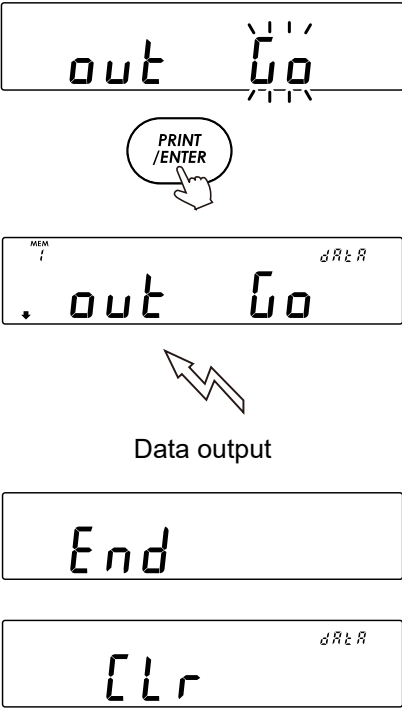
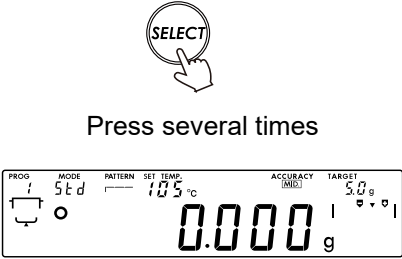
Step	Description	Display and key operation
5.	Press the ENTER key. All the recorded data is output from the RS-232C or USB terminal.	 <p>PRINT / ENTER</p> <p>MEM 1 dRtR</p> <p>. out Go</p> <p>Data output</p> <p>End</p> <p>Clr dRtR</p>
6.	Press the RESET key to return to the mass display.	 <p>SELECT</p> <p>Press several times</p> <p>PROG MODE PATTERN SET TEMP ACCURACY TARGET i Std 105 °C 5.0g</p> <p>0.000 g</p>

Example Output









With data memory output, the data is output in a format like the following.

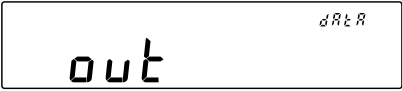

```

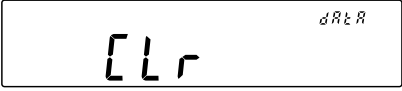
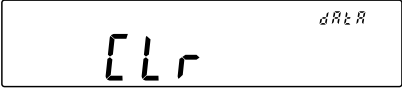
PROGRAM No. 1
PROGRAM ID
      P 001
MODE STANDARD
      MID.
DRYING STANDARD
      180 C
OFFSET 1.23 %
RESULT MOIST /W
      7.692 %
JUDGMENT OK
DATE 2024/02/14
TIME 19:15:57
-----

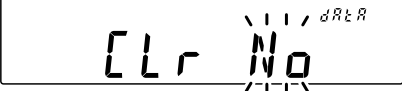
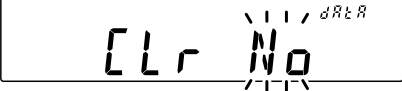
```

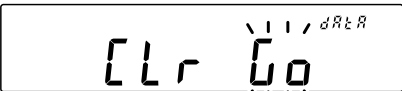
10.3. Batch Erasure of Recorded Results

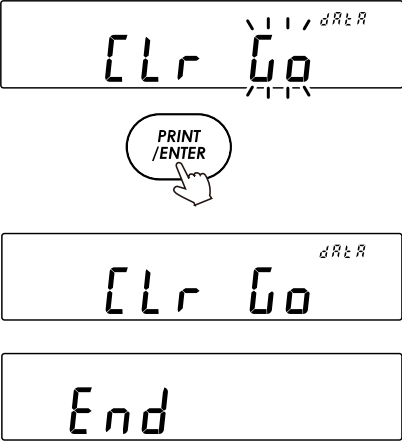
Step	Description	Display and key operation
1.	Press and hold the ENTER key (for approx. two seconds) with the mass displayed.	  <p>Long press (for approx. two seconds)</p> 
2.	Press the SELECT key several times to display CLr , as required. *When GLP output is enabled (when " GLP (GLP output)" is set to "2" or "4"), L 5t and S 6 are displayed.	 <p>Press several times</p> 
3.	Press the ENTER key.	  
4.	Press the SELECT key.	  

Step	Description	Display and key operation
5.	Press the ENTER key. All the recorded data is deleted.	
6.	When the process is complete, the product automatically returns to the mass display. The data number is reset to zero.	

11. Password Function

The password function enables the use of the moisture analyzer and its functions to be restricted.

This is useful for preventing modifications to the date and time settings and changes to the internal settings by non-administrator users.

Enter one of five keys four times for the password.

This allows for $5 \times 5 \times 5 \times 5 = 625$ combinations.

Five keys: **PROGRAM**, **↓**, **↑**, **SELECT**, and **ENTER**

The password function is disabled by default.

Enable/disable the password function and enter the password in "[8. Internal Settings](#)".

"PW (the password function)" in "*PASSWD* (password)" can be set to one of three values in "[8. Internal Settings](#)".

Set value	Function
PW = 0	No password function
PW = 1	Request password entry to use the moisture analyzer
PW = 2	Request the administrator password to log in when changing settings

PW = 0 No password function

The password function is not used.

Anyone can measure moisture content.

All functions can be used.

Settings can also be changed.

PW = 1 Request password entry to use the moisture analyzer

The administrator (ADM, N) can set a unique password to restrict the users of the moisture analyzer.

The default administrator (ADM, N) password is "PPPP" (PROGRAM key four times).

Password entry is required to display the mass with the [RESET] key when the display is off.

The moisture analyzer cannot display the mass unless the correct password is entered.

There are two login levels: administrator (ADM, N) and user (USER 01 to USER 10).

Login level	Description
Administrator (ADM, N)	All functions and settings can be used.
	A separate password can be set for 10 users.
User (USER 01 to USER 10)	Initialization, setting changes (including the clock), mass sensor sensitivity adjustment, heating temperature adjustment, and measurement condition changes are restricted.
No password	The moisture analyzer cannot be used.

PW = 2 Request the administrator password to log in when changing settings

With this function, anyone can perform measurement with the moisture analyzer but initialization and setting changes (including the clock) are restricted.

(Password entry is not required to display the mass with the [RESET] key when the display is off.)

There are two login levels: administrator (ADM, N) and guest (GUEST).

Login level	Description
Administrator (ADM, N)	All functions and settings can be used.
Guest (GUEST) No password*1	Initialization, setting changes (including the clock), mass sensor sensitivity adjustment, heating temperature adjustment, and measurement condition changes are restricted.

*1 If you log in by pressing the [RESET] key while holding the [STOP] key with the display off, administrator (ADM, N) password entry is requested.

Items Limited by Login Level

Item	Login level		
	Administrator (ADM, N)	User (USER 01 to 10)	Guest (GUEST)
Password entry (when logging in)	Required		Not required
Mass sensor sensitivity adjustment/heating temperature adjustment	Yes	No	
Changing internal settings (time/date settings, etc.)	Yes	No	
Changing the measurement conditions	Yes	No*2	
Changing the program number	Yes	Yes*2	
RsTemp (moisture analyzer unit)	Yes	No	
RsTemp (computer software)	Yes	Yes	









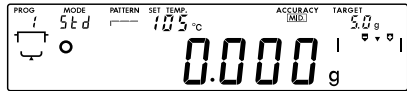

*2 A program number can be used to select an arbitrary measurement condition from among multiple measurement conditions.

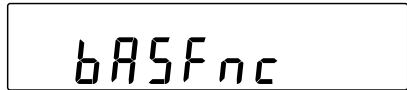
Individual measurement conditions cannot be changed because the functionality is restricted.

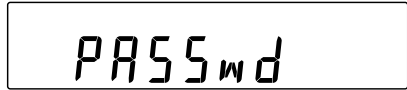
11.1. Preparing the Password Function

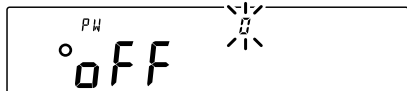
PW (the password function) in "PASSwd (password)" can be "enabled (PW = 1 or 2)" or "disabled (PW = 0)" in "8. Internal Settings".

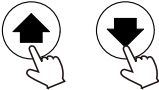
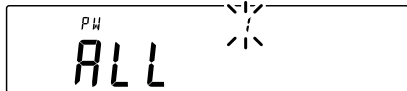
Procedure

Step	Description	Display and key operation
1.	Press and hold the SELECT key (for approx. two seconds) with the mass displayed to display the "8. Internal Settings" menu.	  Press and hold (for approx. two seconds) 
2.	Press the SELECT key several times to match the display with the figure.	 Press several times 
3.	Press the ENTER key to display the "PW (password function)" item. (Press the RESET key to cancel.)	 
4.	Press the   keys to display "1 (enabled: restrict use of the moisture analyzer)" or "2 (enabled: allow moisture measurement)".	 Press several times  or 

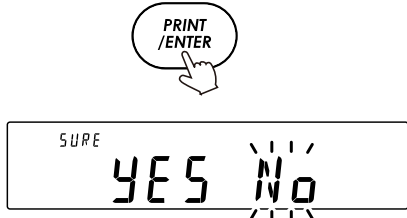
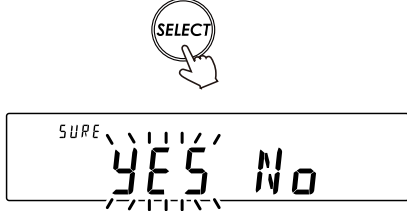
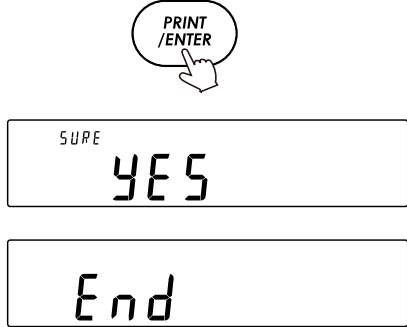
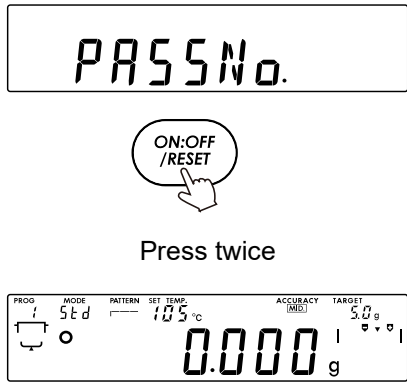
Step	Description	Display and key operation
5.	Press the ENTER key to match the display with the figure. (<i>No</i> flashes while <i>No</i> is selected)	
6.	Press the SELECT key to switch <i>YES</i> / <i>No</i> so that <i>YES</i> flashes.	
7.	With <i>YES</i> selected, press the ENTER key to enable the password function.	
8.	The screen changes to that indicated in the figure. To cancel registration (modification), press the RESET key twice to return to the mass display. To register (change) the password, proceed to step 5 of " 11.2. Registering (Changing) the Password ".	









11.2. Registering (Changing) the Password

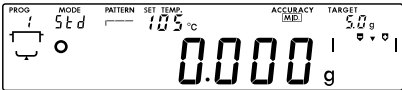

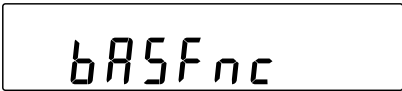

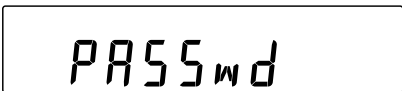
The password can be registered or changed in "PASS No. (register password)" in "PASS wd (password)" in "8. Internal Settings".

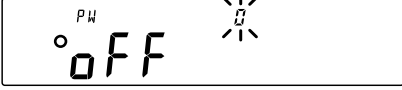

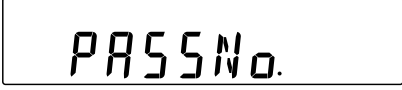

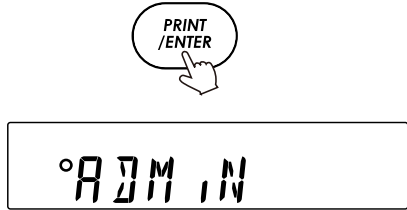

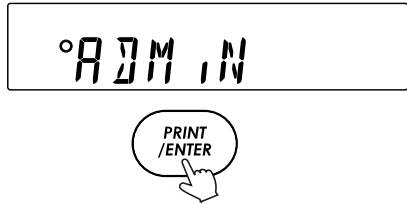
CAUTION

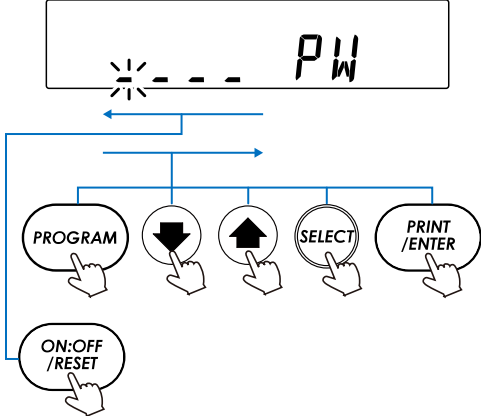
- The **RESET** key can be pressed and held (for approx. two seconds) to turn the display off (log out).
- When set to *Lock* = 2, administrator (*ADMIN*) password entry is required to log in as the administrator. Password entry is not required for users (*USER 01* to *USER 10*).
- The moisture analyzer will not be able to use if the password is forgotten. Make a record of the registered password and store/manage it appropriately.
- The same password as that registered for the administrator (*ADMIN*) cannot be registered for users (*USER 01* to *USER 10*).
- For information on deleting a password, refer to "11.5. How to Delete a User (USER) Password".

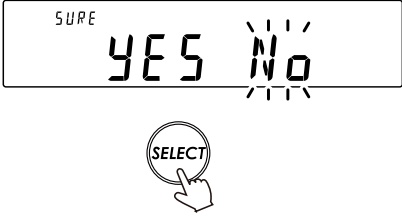
How to Register (Change) the Password

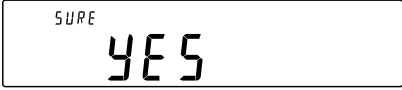
Step	Description	Display and key operation
1.	Press and hold the SELECT key (for approx. two seconds) with the mass displayed to display the "8. Internal Settings" menu.	  Press and hold (for approx. two seconds) 
2.	Press the SELECT key several times to match the display with the figure.	 Press several times 
3.	Press the ENTER key to display the "PW (password function)" item.	 
4.	Press the SELECT key.	 

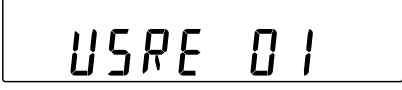





Step	Description	Display and key operation
5.	Press the ENTER key to display the login level (<i>ADMIN</i>).	
6.	Press the SELECT key to display the login level to change. In this example, display administrator (<i>ADMIN</i>). “ o (the safety icon)” lights for login levels which already have a password registered. The password can be changed.	
7.	Press the ENTER key on the login level to register (change) the password of. In this example, change the password of the administrator (<i>ADMIN</i>).	
8.	The current password is displayed. (The default administrator (<i>ADMIN</i>) password is set to "PPPP" (PROGRAM key four times).)	
9.	Perform the following key operation to enter the four digit password. If no key operations are performed for 10 minutes, the screen automatically returns to the login level display. PROGRAM key input P ↓ key input 7 ↑ key input 4 SELECT key input 5 ENTER key input E RESET key go one character back No key operations for 10 minutes screen automatically returns to login level display	

Step	Description	Display and key operation
10.	The new password is displayed after pressing the key four times.	
11.	Press the SELECT key to switch <i>YES / No</i> so that <i>YES</i> flashes.	 
12.	With <i>YES</i> selected, press the ENTER key to register the password.	  
13.	When configuration is complete, the next login level is displayed. To continue configuration, repeat the procedure from step 6.	
14.	To finish configuration, press the RESET key three times to return to the mass display.	 <p data-bbox="1070 1373 1283 1402">Press three times</p> 

11.3. How to Log In

Logging In as the Administrator (*ADMIN*) or a User (*USER 01* to *USER 10*)

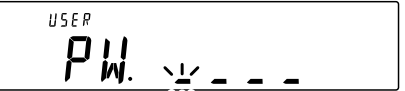
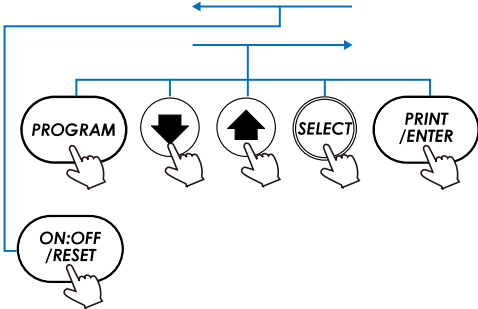
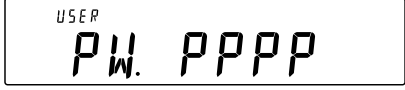
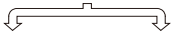
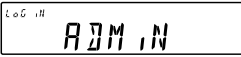
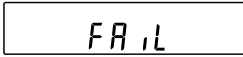
If *PW* (the password function) in *PASSWORD* (password) is set to *PW = 1* (enabled: restrict use of moisture analyzer) in "8. Internal Settings", password entry is required when logging in.







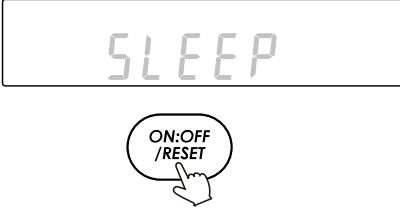
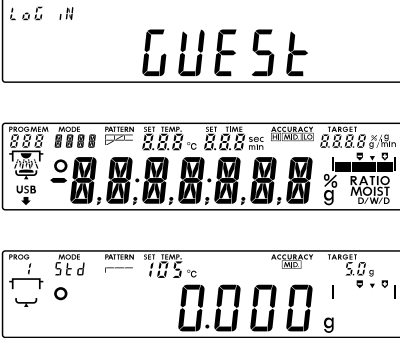

Step	Description	Display and key operation
1.	Press the RESET key with the display off. (Refer to "11.4. How to Log Out" to switch to the display off state.)	 
2.	Password entry is displayed.	
3.	Perform the following key operation to enter the four digit password. If no key operations are performed for 10 minutes, the screen automatically turns off. PROGRAM key input <i>P</i>  key input <i>7</i>  key input <i>4</i> SELECT key input <i>5</i> ENTER key input <i>E</i> RESET key go one character back No operations performed for 10 minutes display off	 
4.	If the password matches, the login level is displayed, the entire display lights up, then the screen switches to the mass display. Enter the password of the administrator to log in as the administrator. (The default administrator password is set to "PPPP" (PROGRAM key four times).) If you enter the wrong password, a buzzer sounds three times with FAIL displayed, then the display turns off.	  Password matches Password does not match   Buzzer × 3  Display off  Mass display

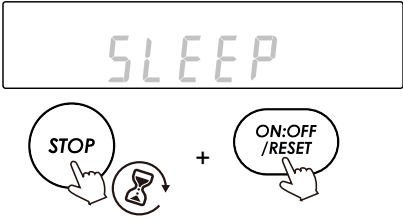
Logging In as a Guest (GUEST)

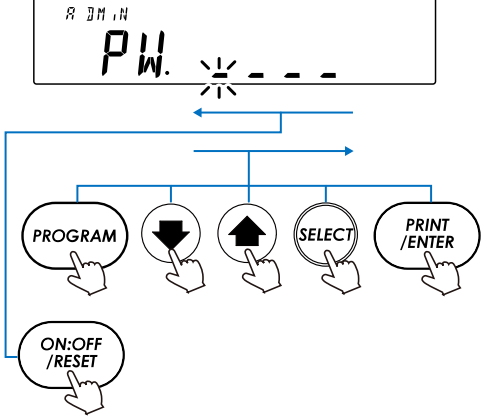

If "PW (the password function)" in "PASSWORD (password)" is set to "PW = 2" (enabled: moisture measurement available)" in "8. Internal Settings", password entry is not required when logging in.

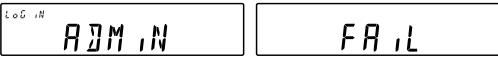
Step	Description	Display and key operation
1.	Press the RESET key with the display off. (Refer to "11.4. How to Log Out" to switch to the display off state.)	
2.	The screen switches to that indicated in the figure, then switches to the mass display.	

Logging In as the Administrator (ADMIN)

Step	Description	Display and key operation
1.	<p>With the display off, press the RESET key while holding the STOP key.</p> <p>(Refer to "11.4. How to Log Out" to switch to the display off state.)</p>	 <p>Hold</p>
2.	<p>Password entry is displayed.</p>	
3.	<p>Perform the following key operation to enter the four digit password.</p> <p>If no key operations are performed for 10 minutes, the screen automatically turns off.</p> <p>PROGRAM key input P  key input 7  key input 4 SELECT key input 5 ENTER key input E RESET key go one character back</p> <p>No operations performed for 10 minutes display off</p>	
4.	<p>If the password matches, the login level is displayed, the entire display lights up, then the screen switches to the mass display.</p> <p>Enter the password of the administrator to log in as the administrator.</p> <p>(The default administrator password is set to "PPPP" (PROGRAM key four times).)</p> <p>If you enter the wrong password, a buzzer sounds three times with FAIL displayed, then the display turns off.</p>	 <p> ← Password matches → Password does not match </p> <p>  </p> <p>Buzzer × 3</p> <p>  </p> <p>Display off</p> <p>  </p> <p>Mass display</p>

11.4. How to Log Out





Step	Description	Display and key operation
1.	<p>The RESET key can be pressed and held (for approx. two seconds) to log out and turn the display off.</p> <p>The display is dark when it is off.</p> <p>When $PW = 1$, password entry is required to display the mass again if the display is off.</p> <p>If "$P - OFF$ (auto power off)" is set to "$P - OFF = 1$ (enabled)" in "$bASFnc$ (environment/display)" in the internal settings, the display will automatically turn off if no operations are performed for 10 minutes.</p>	 <p>ON:OFF /RESET</p> 





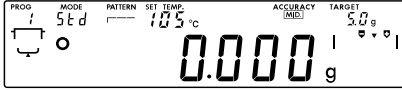
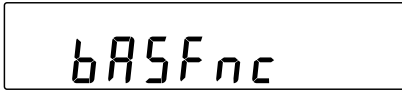

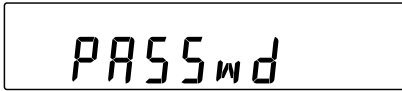

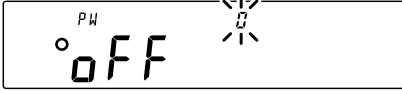

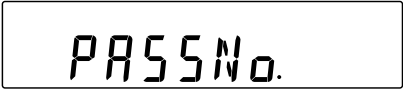

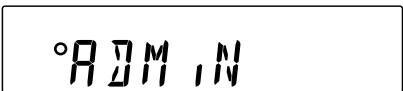
11.5. How to Delete a User (USER) Password

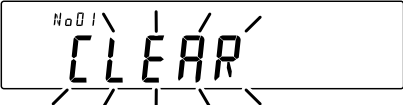

CAUTION

- The administrator (ADM, N) password cannot be deleted. Refer to "[11.2. Registering \(Changing\) the Password](#)" to change it to a password of your choice.

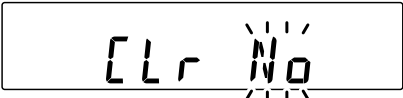
How to Delete a Password

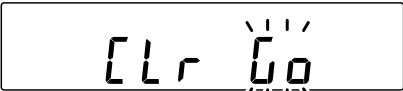
Step	Description	Display and key operation
1.	Press and hold the SELECT key (for approx. two seconds) with the mass displayed to display the " 8. Internal Settings " menu.	 <p>Press and hold (for approx. two seconds)</p> 
2.	Press the SELECT key several times to match the display with the figure.	 <p>Press several times</p> 
3.	Press the ENTER key to display the "PW (password function)" item.	 

Step	Description	Display and key operation
4.	Press the SELECT key to match the display with the figure.	 
5.	Press the ENTER key to display the login level (ADMIN).	 
6.	Press the SELECT key to display the login level to change. In this example, display USER 01 (user 01). “  (the safety icon)” lights for login levels which already have a password registered.	 Press several times 
7.	Press the ENTER key. The current password is displayed.	 
8.	Press and hold the RESET key (for approx. two seconds) while entering the password to match the display with the figure.	 Press and hold (for approx. two seconds) 
9.	Press the ENTER key to match the display with the figure.	 
10.	Press the SELECT key to switch $\bar{C}0 / No$.	 

Step	Description	Display and key operation
11.	With  flashing, press the ENTER key to delete the password.	 <div style="border: 1px solid black; padding: 5px; text-align: center; margin: 5px 0;">End</div> <div style="border: 1px solid black; padding: 5px; text-align: center; margin: 5px 0;">USER 01</div>

11.6. If the Administrator (ADMIN) Password Is Forgotten

The moisture analyzer will not be able to use if the password is forgotten.

To cancel the password, the product must be returned to A&D for a repair. Request a repair.

12. Interface Specifications

12.1. USB

Connector	Type-C (female)
Standard	USB 2.0
Device class	HID (human interface device): Quick USB CDC (communication device class): Virtual COM

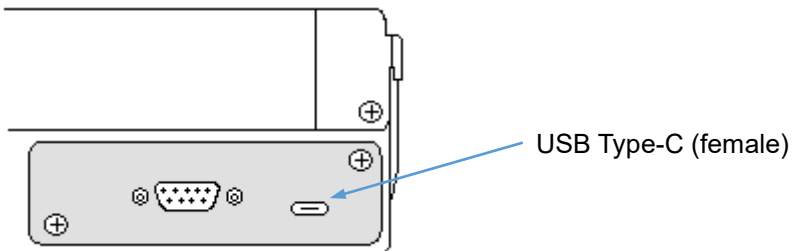

CAUTION

- Power cannot be supplied from a USB AC adapter or mobile battery.
- Do not connect a USB AC adapter or mobile battery, as doing so may cause product failure.
- USB Type-C USB memory cannot be used.
- Power cannot be supplied to external devices from the moisture analyzer.

12.2. RS-232C

Connector	9-pin D-Sub (male)	
Communication method	EIA RS-232C	
Communication format	Bidirectional asynchronous communication method	
Data transfer rate	Approx. 5 times/second	
Signal format	Baud rate	2400 bps
	Data bits	7 bits
	Parity	Even
	Stop bits	1 bit
	Encoding	ASCII encoding

One character format

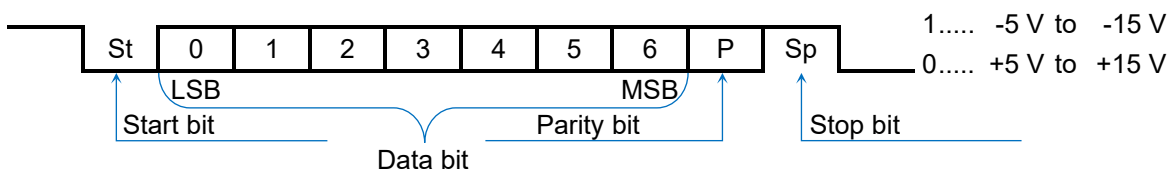

9-pin D-Sub pin layout

Pin no.	Signal name	Direction	Description/Remarks
1	-	-	Same potential as SG ^{*1}
2	TXD	Output	Sent data
3	RXD	Input	Received data
4	-	-	N.C.
5	SG	-	Signal ground
6	DSR	Output	Data set ready
7	RTS	Input	Request transmission
8	CTS	Output	Allow transmission
9	-	Output	12 V output ^{*1}

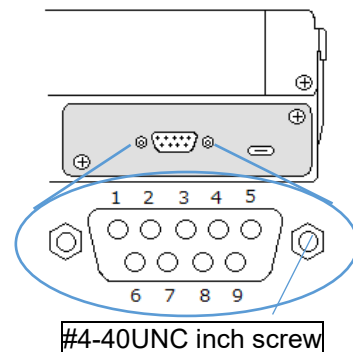

Signal names other than TXD and RXD are the names on the DTE side.

Wiring diagram
(for computer connection)

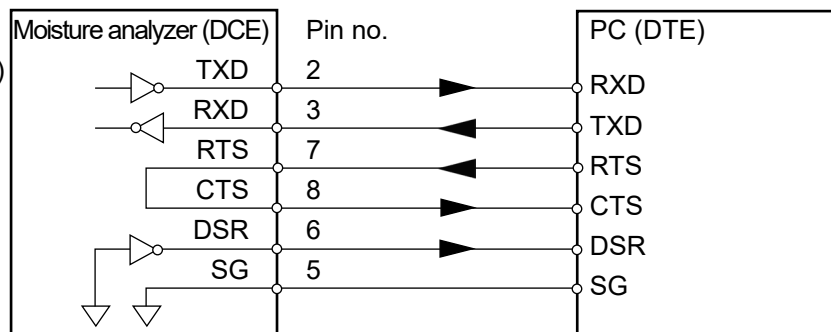

^{*1} Used for some A&D peripherals. Do not wire these pins when connecting to a device from another manufacturer where power is output. Make sure to use a compliant cable, as using an incorrect connection cable may damage the device.

13. Connecting to a Peripheral

You can use the standard RS-232C connector and USB Type-C connector of the moisture analyzer to connect to a peripheral, computer, or device such as a PLC.

13.1. Cables Used for Connecting to a Peripheral

"Cables used for connecting to peripherals" indicates the connection cables compliant with the interfaces used with peripherals.

Cables used for connecting to peripherals

Peripheral		Communication interface used	Connection cable		Remarks
Product name	Product code		Standard/optional	Cable product code	
Multi printer	AD-8127	RS-232C	[Included as standard] RS-232C cable included with printer	AX-KO2741-100	
Thermal printer	AD-8129TH		[Sold separately]		*1
Computer		USB	[Included as standard] *2 USB cable included with moisture analyzer	AX-KO7919-200	

*1 Uses AX-USB-9P, AD-8541-SCALE, and AD-1688 to connect with the computer.

When exchanging data, the connection cable included with these products can be used.

*2 UL certified products do not include a USB cable.

13.2. Printing Mass and Moisture Content Values to a Printer

The table below indicates internal settings of the moisture analyzer and example printer settings for printing data such as the moisture content.

13.2.1. For the AD-8127 or AD-8129TH

- The standard RS-232C interface can be used to print measurement results and sensitivity adjustment records supporting GLP/GMP/ISO to a multi printer (AD-8127) or thermal printer (AD-8129TH).
- The functions of the AD-8127 or AD-8129TH can be used to print changes in the moisture content over a fixed period of time and the results of processing statistics about the measurement results.
- Use the cable included with the AD-8127 or AD-8129TH to connect.

Setting correspondence chart

How to use	Internal settings of moisture analyzer				AD-8127 setting PRN MODE
	<i>P r t</i>	<i>S - d</i>	<i>P U S E</i>	<i>i n f o</i>	
Print measurement results including measurement conditions (non-statistical computation)	0, 1	0	0	1, 2, 3, 4	DUMP Dump print mode
Print measurement results (statistical computation)	0, 1	0	0	0	EXT.KEY External key print mode
Output changes in moisture content	2	0	0	0	TIMER Interval print mode
GLP/GMP/ISO compatible printing	0, 1	0	0	1, 2, 3, 4	DUMP Dump print mode
Output measurement data with data memory function	0, 1	0	0	0, 1, 2, 3, 4	DUMP Dump print mode

For details on the settings, refer to "8. Internal Settings" and the instruction manual of the printer.

13.3. Connecting to a Computer

13.3.1. Virtual COM Mode

The virtual COM mode function enables you to use the included USB cable *1 to connect the moisture analyzer to a computer and create a COM port on the computer to perform bidirectional communication. Operating systems from Windows XP and later are supported. With Windows 10 and Windows 11, the driver is automatically installed. If the driver is not automatically installed, refer to the PDF file in "[Driver for Virtual COM Mode-](#)" on the A&D website (<https://www.aandd.jp>).

By selecting the COM port in software such as the WinCT-Moisture data communication software, you can perform communication equivalent to RS-232C.

With the virtual COM mode, it is not necessary to configure the baud rate, data bit, parity, and stop bit of the data communication software.

*1 UL certified products do not include a USB cable.

CAUTION





- It may take some time to install the driver for the virtual COM mode for the first time.
- The output format is fixed to the standard A&D format.

How to Use

In this example, the **ENTER** key or a data request command from a computer is used to output the mass value and moisture content from the moisture analyzer.

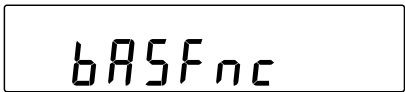

Switching the USB Operation Mode (Changing the Internal Settings)



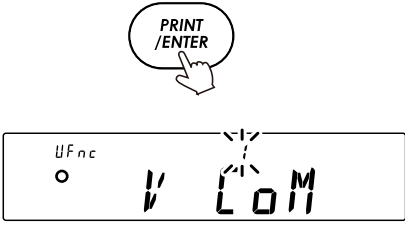
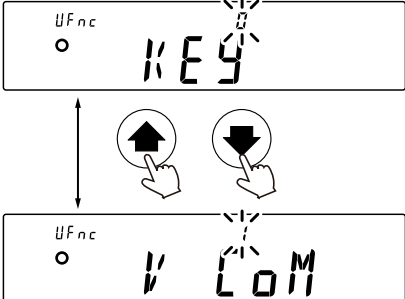
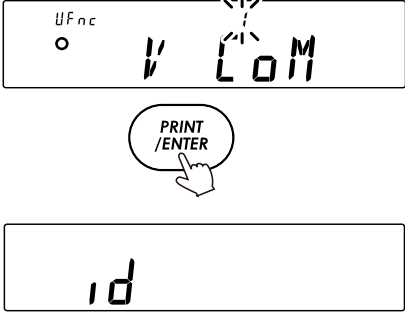
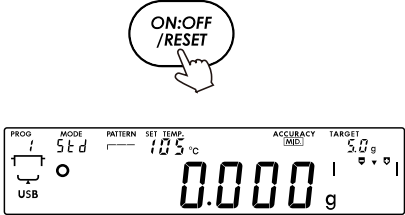

Switch to the virtual COM mode ($UFnc = ;$) (for bidirectional communication).

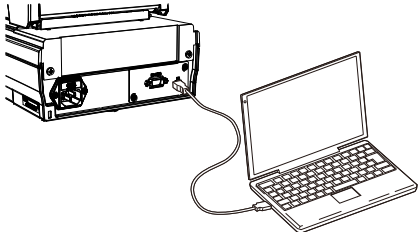

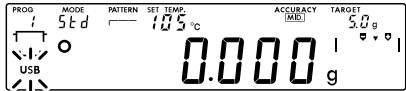
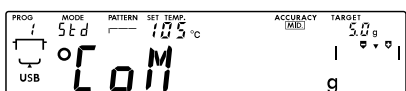
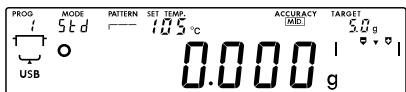
Step	Description	Display and key operation
1.	Press and hold the SELECT key (for approx. two seconds) with the mass displayed to display the "8. Internal Settings" menu.	  Press and hold (for approx. two seconds) 
2.	Press the SELECT key several times to match the display with the figure.	 Press several times 

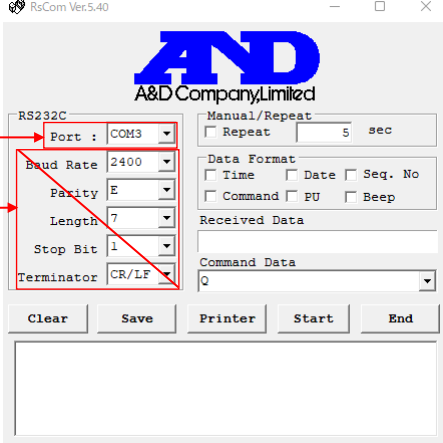
Step	Description	Display and key operation
3.	Press the ENTER key.	
4.	Press the ↑ or ↓ key to switch the value of the “ <i>UFnc</i> (USB operation mode)” setting to “ <i>UFnc</i> = 1 (virtual COM mode)”.	
5.	Press the ENTER key when the screen switches to that indicated in the figure to register the settings.	
6.	Press the RESET key to return to the mass display.	

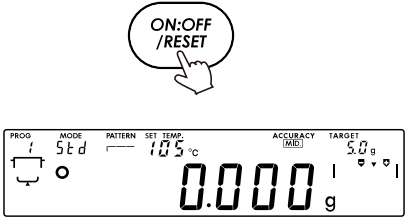
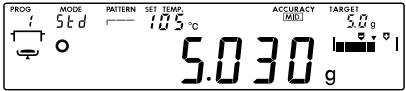
Output Method

Step	Description	Display and key operation
1.	<p>Use the USB cable included with the moisture analyzer ^{*1} to connect the moisture analyzer to the computer.</p>  <p>When connecting for the first time with Window 10 or Windows 11, the computer will automatically start installing the driver.</p> <p>With an operating system other than Windows 10 or Windows 11, the driver must be manually installed.</p> <p>For information on installing the driver, refer to the PDF file in "Driver for Virtual COM Mode-" on the A&D website (https://www.aandd.jp).</p> <p>^{*1} UL certified products do not include a USB cable.</p>	
2.	<p>When the moisture analyzer connects to the computer, USB flashes on the display of the moisture analyzer, as indicated in the figure. (This indicates that communication with the computer is being established.)</p>	
3.	<p>When communication is established between the moisture analyzer and the computer, the virtual COM connection is indicated on the display of the moisture analyzer (for approx. two seconds) as indicated in the figure, then the screen automatically switches to the mass display.</p> <p>The "USB" icon (USB connection icon) lights while the product is connected via USB.</p>	 <p>Displayed for approx. two seconds</p> 
4.	<p>Start the computer software for sending the mass and moisture content values (such as WinCT).</p>	

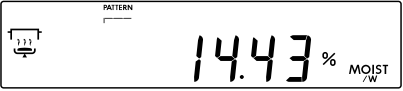
Step	Description	Display and key operation
5.	<p>By selecting the COM port, you can perform communication equivalent to RS-232C. With the virtual COM mode, it is not necessary to configure the baud rate, data bit, parity, and stop bit of the data communication software.</p> <p>For information on how to operate WinCT, download and read the required instruction manual from "Software Downloads" on the A&D website (https://www.aandd.jp).</p> <p>Example for RsCom</p> 	
6.	<p>Press the RESET key to reset the display to zero.</p>	
7.	<p>Place the object to measure on the sample tray.</p>	
8.	<p>Press the ENTER key on the moisture analyzer or send a data request command from the computer.</p> <p>The mass value is output from the moisture analyzer.</p> <p>Example output</p> <pre>ST,+0005.030...g<TERM></pre> <p> . : Space (ASCII 20h) <TERM> : Terminator (CR LF) CR : Carriage return (ASCII 0Dh) LF : Line feed (ASCII 0Ah) </p>	 <p>or</p> <p>Send data request command from computer</p>  <p>Data output</p>

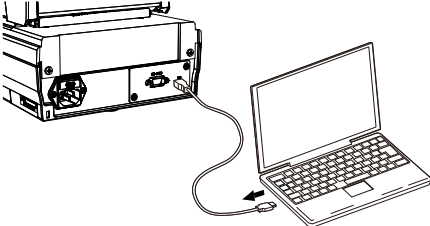
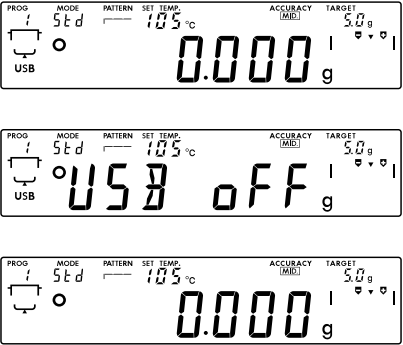
Step	Description	Display and key operation
9.	Measure the moisture content.	
10.	<p>Press the ENTER key on the moisture analyzer or send a data request command from the computer.</p> <p>The moisture content value is output from the moisture analyzer.</p> <p>Example output</p> <pre>ST,+00014.43_%<TERM></pre> <p> _ : Space (ASCII 20h) <TERM> : Terminator (CR LF) CR : Carriage return (ASCII 0Dh) LF : Line feed (ASCII 0Ah) </p>	 <p>or</p> <p>Send data request command from computer</p>  <p>Data output</p>
11.	<p>To end the procedure, remove the USB cable.</p>  <p>When the moisture analyzer disconnects from the computer, the USB connection icon (USB) disappears.</p>	

13.3.2. Quick USB Mode

The Quick USB mode enables you to connect the moisture analyzer to a computer via a USB cable to directly input the output of the moisture analyzer to computer software such as Excel or Word. Operating systems from Windows XP and later are supported.

Because the standard Windows driver (HID) is used, a dedicated driver does not need to be installed and communication can be performed simply by connecting the USB cable.

CAUTION

- The quick USB mode performs one-way communication from the moisture analyzer to the computer. Commands cannot be sent from the computer to the moisture analyzer.
- The output format is fixed to the NU2 format.
- Make sure to disable the screen saver and standby mode of the computer.
- Do not use the quick USB mode when the data output mode of the moisture analyzer is set to the stream mode.







Because the stream mode continuously outputs the mass value from the moisture analyzer to the computer, it may cause the computer to operate in an unexpected manner.

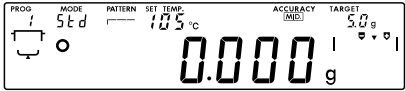

How to Use

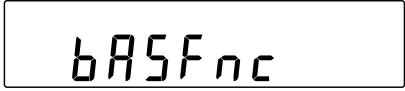
In this example, the **ENTER** key is used to output the mass value and moisture content from the moisture analyzer.

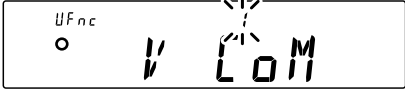
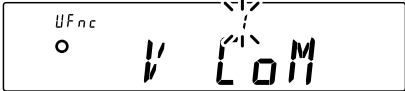
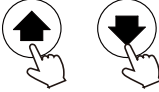
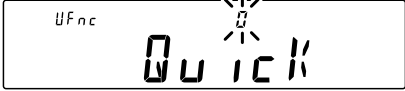

Switching the USB Operation Mode (Changing the Internal Settings)

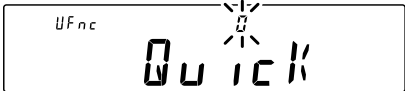
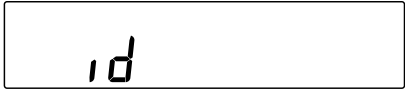

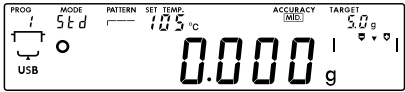

Switch to the quick USB mode ($UF_{nc} = \text{Q}$) (for one-way communication).

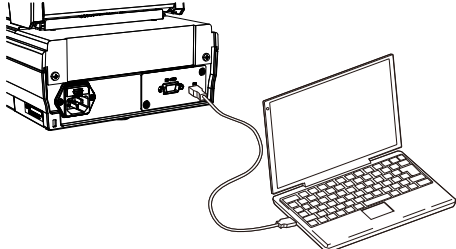
Step	Description	Display and key operation
1.	Press and hold the SELECT key (for approx. two seconds) with the mass displayed to display the "8. Internal Settings" menu.	  Press and hold (for approx. two seconds) 
2.	Press the SELECT key several times to match the display with the figure.	 Press several times 
3.	Press the ENTER key.	 
4.	Press the ↑ or ↓ key to switch the value of the "UF _{nc} (USB operation mode)" setting to "UF _{nc} = Q (quick USB mode)".	  

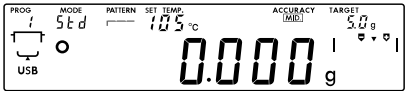
Step	Description	Display and key operation
5.	Press the ENTER key when the screen switches to that indicated in the figure to register the settings.	 
6.	Press the RESET key to return to the mass display.	 

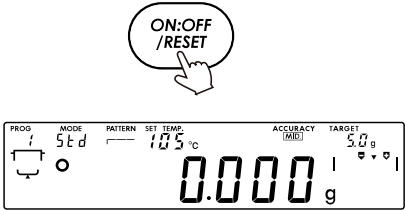
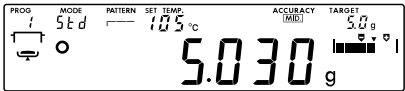
Output Method

Step	Description	Display and key operation
7.	<p>Use the USB cable included with the moisture analyzer ^{*1} to connect the moisture analyzer to the computer.</p>  <p>When connecting for the first time, the computer will automatically start installing the driver.</p> <p>^{*1} UL certified products do not include a USB cable.</p>	
8.	<p>When the moisture analyzer connects with the computer, the quick USB connection is indicated on the display of the moisture analyzer (for approx. two seconds) as indicated in the figure, then the screen automatically switches to the mass display.</p> <p>The "USB connection icon (USB)" is lit while the product is connected via USB.</p>	 <p>Displayed for approx. two seconds</p> 
9.	Launch the computer software to send the mass and moisture content values to (such as Excel).	
10.	Set the keyboard input mode to half-width input. Values cannot be input correctly if it is set to full-width input.	

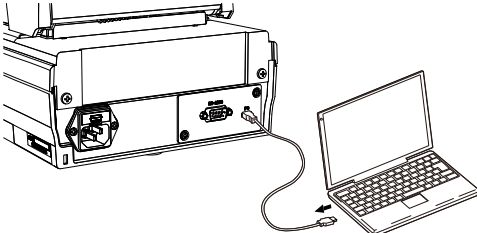
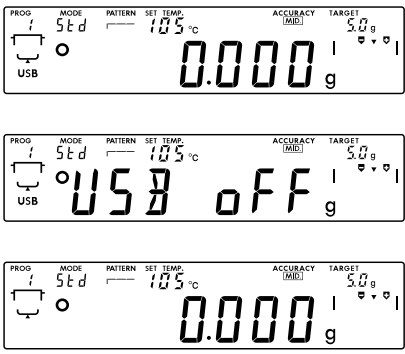
Step	Description	Display and key operation
11.	Press the RESET key to reset the display to zero.	
12.	Place the sample on the sample tray.	
13.	Place the cursor in the location to input the mass value.	
14.	Press the ENTER key to send the mass value from the moisture analyzer and input it to the location of the cursor.	 <p data-bbox="1145 1106 1286 1137">Data output</p>
15.	Measure the moisture content.	
16.	Press the ENTER key to send the moisture content value from the moisture analyzer and input it to the location of the cursor.	 <p data-bbox="1145 1532 1286 1563">Data output</p>
17.	<p data-bbox="236 1630 783 1662">To end the procedure, remove the USB cable.</p>  <p data-bbox="236 1921 954 1995">When the moisture analyzer disconnects from the computer, the USB connection icon (USB) disappears.</p>	

13.3.3. RS-232C

The RS-232C interface of the moisture analyzer is DCE (Data Communication Equipment) that can connect to a computer. A straight-type RS-232C cable is used to connect. If the computer does not have an RS-232C connector, connect it via the virtual COM mode of a USB connector. (For information on the communication settings, refer to "[12.2. RS-232C](#)".)

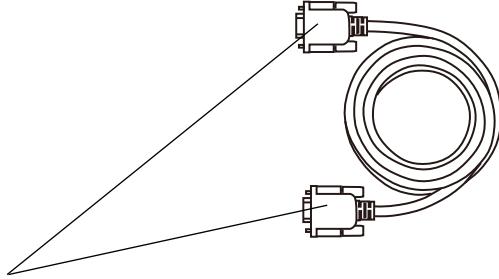

9-pin D-Sub (female), inch screws

13.4. WinCT-Moisture Communication Software

- WinCT-Moisture is data communication software for Windows that enables the data of the moisture analyzer to be imported to a computer for saving or data analysis.
- WinCT-Moisture can be downloaded from "[Software Downloads](https://www.aandd.jp)" on the A&D website (<https://www.aandd.jp>).
- WinCT-Moisture includes two programs: RsFig and RsTemp.

13.4.1. RsFig Graph Software for Moisture Content Measurement

- RsFig is Windows software that enables the data received from the moisture analyzer to be graphed in real-time.
- This enables you to check changes in the moisture content being measured to understand the process by which the moisture content stops changing (the convergence process).
- Graphs can also be overlaid on each other, so when measurement is repeated with different heating temperature conditions, the measurement process can be overlaid on the same graph.
- The measured data can be exported to a CSV file.
- For information on how to change and restrict the settings, refer to the instruction manual for RsTemp (RsFig_ReadMe).

Example display for RsFig

The figure below is an example of overlaying the measurement results for sodium tartrate dihydrate on the graph when the heating temperature is changed by 20°C each time (100 to 200°C).

The horizontal axis is the time elapsed (in minutes) since measurement started and the vertical axis is the moisture content (%).

The mass of the sample will decrease as the water evaporates due to heating, and that decrease in mass is calculated and displayed as the moisture content. When the moisture content stops changing (when the graph becomes flat), that is the moisture content of the sample.

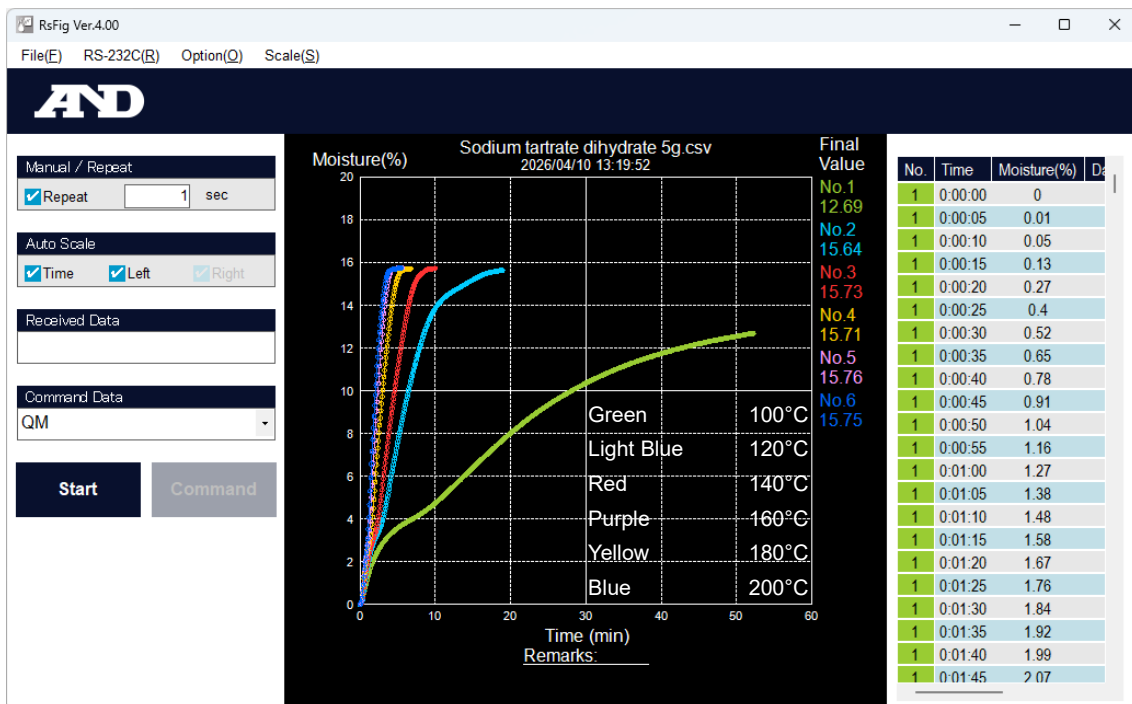



13.4.3. RsSetup Software for Moisture Analyzer Settings

- RsSetup is Windows-based setting software that allows the ID number, internal settings, and measurement programs of the moisture analyzer to be changed from a PC.
- The identification information (ID number) of the moisture analyzer can be read, checked, and changed.
- The internal setting data of the moisture analyzer can be read and changed in a batch. The read internal setting data can be saved in CSV file format.
- Internal setting data can be batch read and batch changed, and can also be saved and loaded in CSV format.
- The measurement programs of the moisture analyzer can be read out in a batch and changed in a batch. The read measurement programs can be saved in TSV file format. Copying and pasting by program number is also possible.
- For details on how to change each setting item and the applicable restrictions, refer to the RsSetup instruction manual (RsSetup_Readme).

Caution

- This software cannot be used if changing settings is prohibited by the password function of the moisture analyzer.
- Internal settings cannot be applied between different models (for example, writing the settings of the MS-74A to the MX-53A).
- Measurement programs can be applied even between different models.

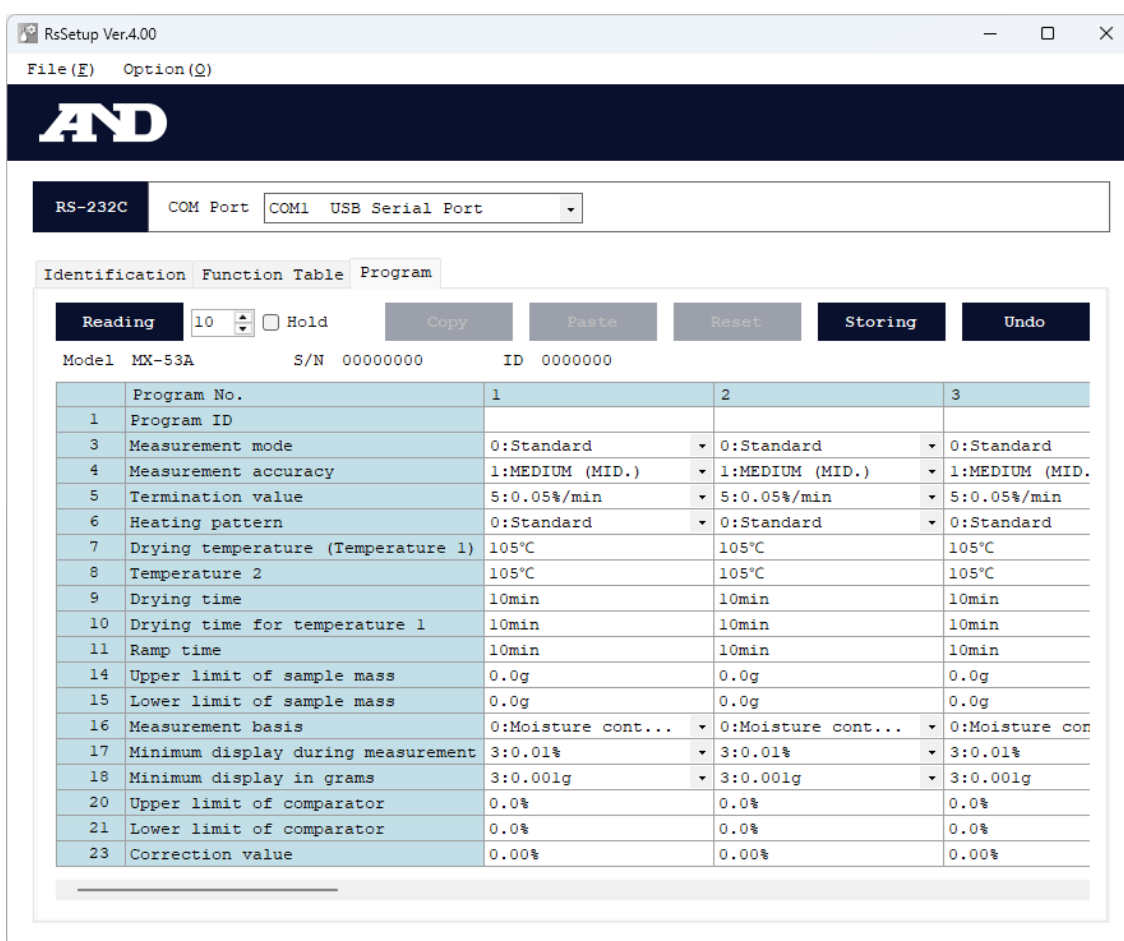

13.5. WinCT Data Communication Software

- WinCT is data communication software for Windows that enables the mass and moisture content values of the moisture analyzer to be easily imported to a computer. It uses RS-232C for communication.
- WinCT can be downloaded from "Software Downloads" on the A&D website (<https://www.aandd.jp>). For information on installing and setting up WinCT, see "Setting Up WinCT" and "WinCT Instruction Manual".
- WinCT includes three programs: RsCom, RsKey, and RsWeight.

"RsCom"

- Enables the moisture analyzer to be controlled by sending commands.
- Displays the received data and saves it as a text file (.txt).
- Multiple instances can be executed to communicate with multiple moisture analyzers.
- Can be executed at the same time as other applications. (Does not monopolize the computer.)
- Can also receive the GLP output data of the moisture analyzer.

"RsKey"

- Enables the mass and moisture content values of the moisture analyzer to be directly input to another application.
- Any application such as Word or Excel can be used, as long as it allows keyboard input.
- Can also input the GLP output of the moisture analyzer.
- Enables the test display function to be used to use a computer as an external display for the moisture analyzer.
(With the moisture analyzer in the stream mode.)

"RsWeight"

- Graphs received data in real-time.
- Enables the maximum, minimum, average, standard deviation, and coefficient of variation of the received data to be calculated and displayed.

13.6. Commands

The following commands can be sent from a computer to control the moisture analyzer.

Add a terminator (0Dh, 0Ah) to the command before sending it to the moisture analyzer.

List of Commands

Command	Description
Q	Sends one measurement value.
SIR	Continuously sends measurement values.
C	Stops continuously outputting measurement values with the SIR command.
QM	Outputs one measurement value during measurement. QM can only be used during measurement.
START	Performs the same function as the <input type="text" value="START"/> key.
STOP	Performs the same function as the <input type="text" value="STOP"/> key.
RESET	Performs the same function as the <input type="text" value="RESET"/> key.
ENTER	Performs the same function as the <input type="text" value="ENTER"/> key.
SELECT	Performs the same function as the <input type="text" value="SELECT"/> key.
DOWN	Performs the same function as the <input type="text" value="↓"/> key.
UP	Performs the same function as the <input type="text" value="↑"/> key.
PROGRAM	Performs the same function as the <input type="text" value="PROGRAM"/> key.

14. How to Check the Software Version of the Moisture Analyzer

The specifications of the product may differ according to the software version of the moisture analyzer. You can follow the procedure below to check the software version.

Procedure for Checking the Software Version

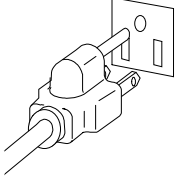
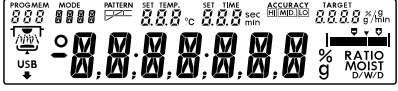
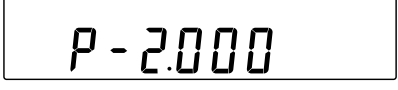
Step	Description	Display and operation
1.	Connect the power cable of the moisture analyzer main unit to the power outlet.	
2.	The LCD of the moisture analyzer will fully light up.	
3.	<code>P-*.***</code> is displayed for approx. one second. The number in <code>*.***</code> is the software version.	

15. Maintenance

- Make sure to remove the power plug from the power outlet before performing maintenance.
- Perform operations after confirming that the various parts of the moisture analyzer have cooled down sufficiently.
- The sample tray, tray holder, and breeze break can be removed.
- Remove any dirt using a cloth that has been dampened with water or water containing a small amount of neutral detergent and wrung out well.
- Do not use organic solvents or chemical wipes.
- Perform assembly as described in "4.1. Installing the Moisture Analyzer" and "1. Cautions Regarding Handling" after the parts are completely dry.
- When transporting the product, use the dedicated packaging box.

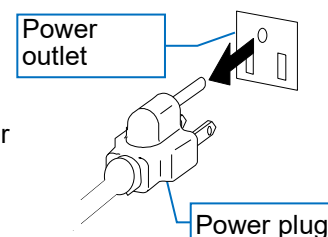

15.1. Cleaning the Heater

- Clean the glass housing if it gets dirty, or it may not be able to heat properly. The glass housing can be easily detached by removing the two screws.
- Clean the halogen lamp if it has any fingerprints on it, or its life may be shortened.
- Do not touch the metal plate for reflection on the rear of the halogen lamp. Doing so may cause the set temperature of the sample tray and the actual heating temperature to deviate.
- Do not touch the temperature sensor adjacent to the halogen lamp. Doing so may cause the set temperature of the sample tray and the actual heating temperature to deviate.

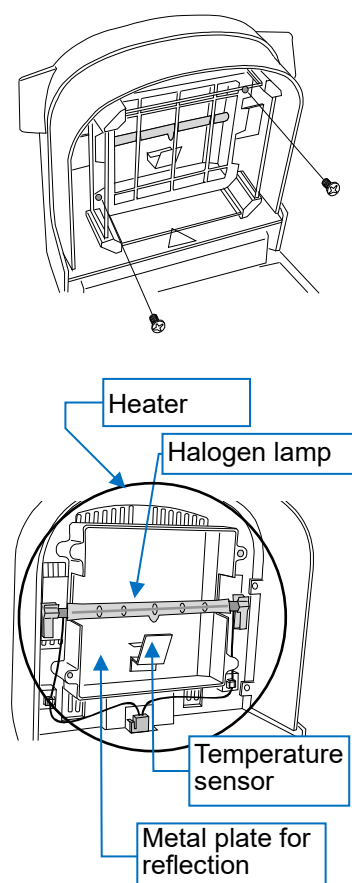
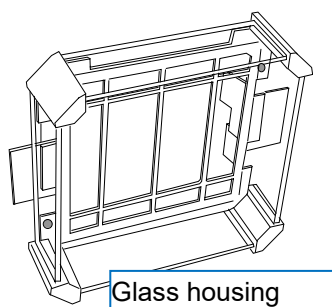

15.2. How to Replace the Halogen Lamp

If drying takes time because the halogen lamp output has decreased due to lamp degradation or the halogen lamp has stopped lighting, replace the halogen lamp. Use the halogen lamp of accessory AX-MX-34-120V *1 or AX-MX-34-240V that is adapted to your local voltage. The expected life of the halogen lamp is approx. 5,000 hours.

CAUTION

- Performing this procedure without removing the power cable can result in electrocution.
- Read the power supply voltage label on the back of the heater cover and confirm that the rated voltage of the halogen lamp is correct for your power supply voltage.

Voltage Label	The Rated Voltage of the Halogen Lamp	Accessory number *1
100 – 120V	AC 120 V	AX-MX-34-120V
200 – 240V	AC 240 V	AX-MX-34-240V

- Do not drop, strike, or damage glass parts including the halogen lamp. Doing so may cause it to break and lead to injury due to glass shards.
- The halogen lamp degrades due to contamination on its surface. Do not directly touch the glass of the halogen lamp.
- Dispose of the used halogen lamp as-is. Breaking a halogen lamp can cause glass shards to scatter, which may result in injury.
- It is recommended that you replace the halogen lamp once it has reached its rated life. Continuing to use it may cause damage to the product.

*1 UL certified products are 120 V Version only.

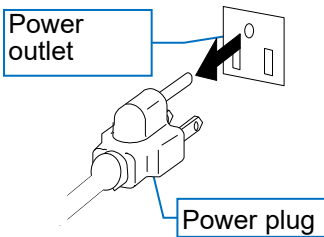
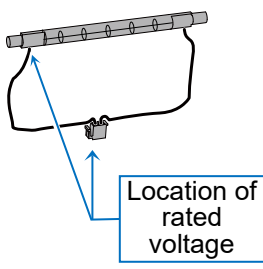
Step	Description	Diagram
1.	Remove the power cable from the power outlet.	
2.	Confirm that the rated voltage of the new halogen lamp. The rated voltage is indicated on the edge of the connector and the halogen lamp.	
3.	Confirm that the heater has sufficiently cooled.	

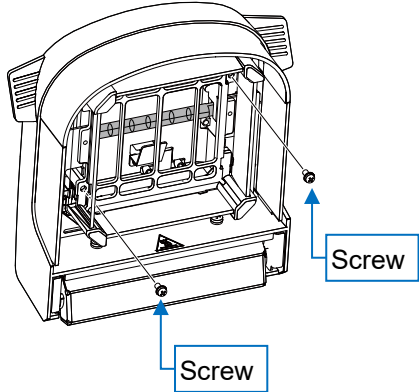
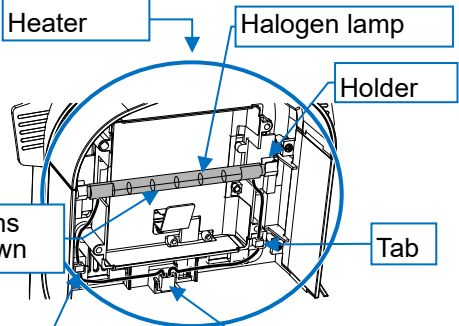
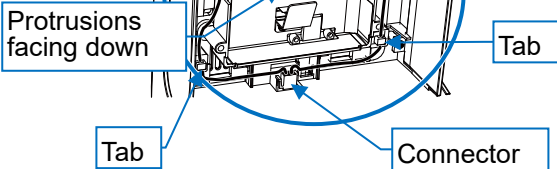
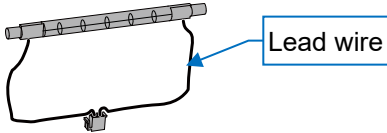
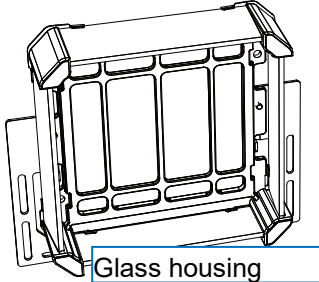
Step	Description	Diagram
4.	Remove the two screws of the glass housing.	 <p>The diagram shows a perspective view of the glass housing assembly. Two screws are indicated with blue arrows and labeled 'Screw' in blue boxes. One screw is located at the bottom center, and the other is on the right side.</p>
5.	Disconnect the connector of the halogen lamp, then remove it from the holder.	 <p>The diagram shows a perspective view of the internal assembly. A blue circle highlights the area where the halogen lamp is connected. Labels include 'Heater' at the top left, 'Halogen lamp' at the top right, 'Holder' on the right, 'Protrusions facing down' on the left, and 'Connector' at the bottom right. A 'Tab' is also labeled on the right side.</p>
6.	Load the halogen lamp with the protrusions facing down, as indicated in the figure, then connect the connector.	 <p>The diagram shows a perspective view of the internal assembly. A blue circle highlights the area where the halogen lamp is being loaded. Labels include 'Protrusions facing down' on the left, 'Tab' at the bottom left, and 'Connector' at the bottom right.</p>
7.	Hook the lead wire of the halogen lamp on the two tabs (on the left and right).	 <p>The diagram shows a perspective view of the lead wire assembly. A label 'Lead wire' points to the wire, which is shown being hooked onto two tabs.</p>
8.	Secure the glass housing with screws so that it does not pinch the lead wire of the lamp.	 <p>The diagram shows a perspective view of the glass housing assembly. A label 'Glass housing' points to the housing.</p>

15.3. How to Replace the Power Fuse

The fuse inside the power supply may blow to protect the moisture analyzer main unit in cases such as when a power supply with the wrong voltage is connected. If the fuse blows, replace it with a new fuse (AX-FST6.3A250V; sold separately).

CAUTION

- Performing this procedure without removing the power cable can result in electrocution.

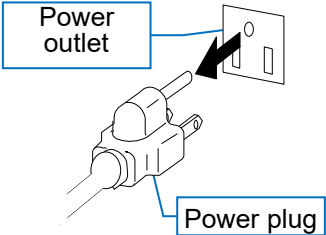
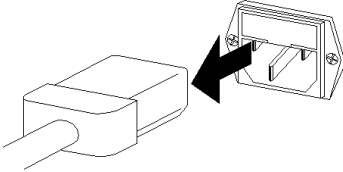
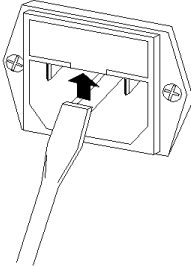
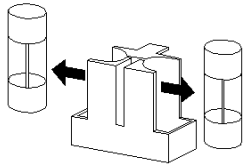
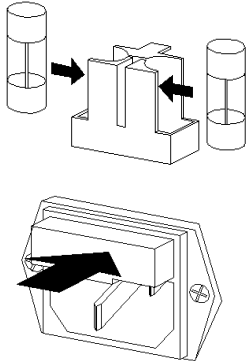
Step	Description	Diagram
1.	Remove the power cable from the power outlet.	
2.	Remove the power cable from the power inlet of the moisture analyzer.	
3.	Use a flat-head screwdriver to remove the fuse cover on the top of the power inlet. (Insert the flat-head screwdriver under the tab on the bottom of the fuse cover, then prise it open to remove the fuse cover.)	
4.	Remove the fuse from the fuse cover, then visually check whether the fuse has blown, or use a multimeter. If the fuse has blown, replace it with a new fuse (sold separately).	
5.	Place the fuse in the fuse cover, then place the fuse cover together with the fuse into the power inlet.	

15.4. Initializing the Settings

You can initialize the settings of the product to restore the factory defaults.

There are two initialization methods, which initialize different settings.











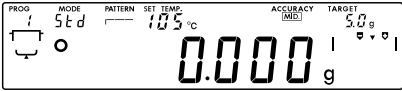

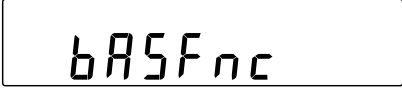
The initialized settings are as follows.

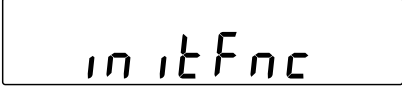

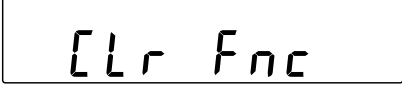

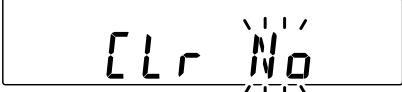
Item	Initialize (internal settings)	Initialize (all settings)
Mass sensor sensitivity adjustment data	No	Yes
Heating temperature adjustment data	No	Yes
Measurement conditions	No	Yes
Internal settings (excluding the password function)	Yes	Yes
ID number	Yes	Yes
Results recorded with the data memory function	Yes	Yes

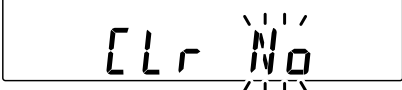
Yes: Initialized

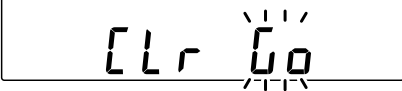

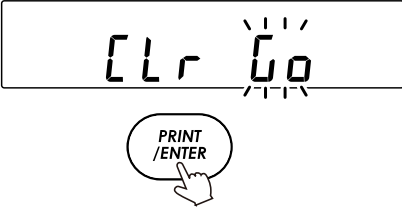
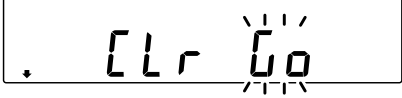







No: Not initialized

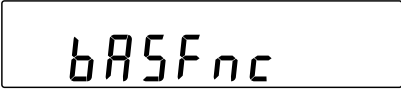

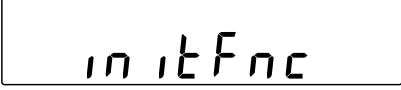

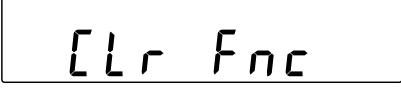
15.4.1. How to Initialize (Internal Settings)

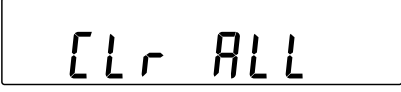
Step	Description	Display and key operation
1.	Press and hold the SELECT key (for approx. two seconds) with the mass displayed to display the "8. Internal Settings" menu.	  Press and hold (for approx. two seconds) 
2.	Press the SELECT key several times to match the display with "in itFnC".	 Press several times 
3.	Press the ENTER key.	 
4.	Press the ENTER key.	 
5.	Press the  or  key to switch to "CLr Go".	   

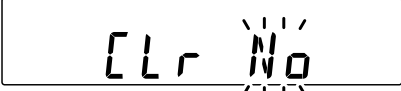
Step	Description	Display and key operation
6.	Press the ENTER key. Initialization completes in several seconds, and End is displayed.	  <p>(Wait several seconds)</p>  
7.	Press the RESET key to return to the mass display.	 

15.4.2. How to Initialize (All Settings)

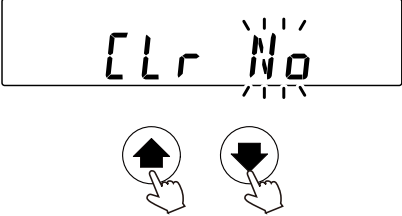
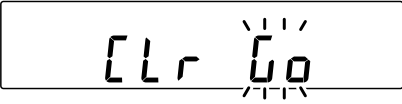
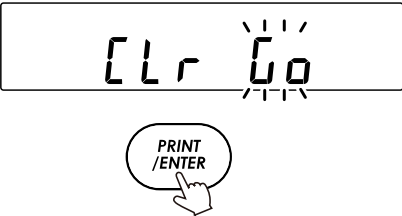
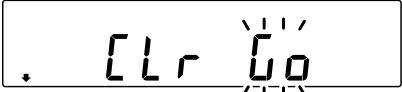
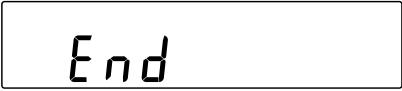
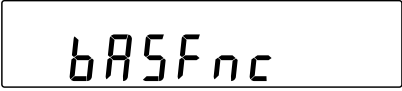
Step	Description	Display and key operation
1.	Press and hold the SELECT key (for approx. two seconds) with the mass displayed to display the "8. Internal Settings" menu.	  Press and hold (for approx. two seconds) 
2.	Press the SELECT key several times to match the display with "int Fnc".	 Press several times 
3.	Press the ENTER key.	 
4.	Press the SELECT key to match the display with "CLr ALL".	 Press several times 
5.	Press the ENTER key.	 

Step	Description	Display and key operation
6.	Press the  or  key to switch to "Go".	 
7.	Press the ENTER key. Initialization completes in several seconds, and End is displayed.	  (Wait several seconds)  
8.	Press the RESET key to return to the mass display.	 

15.5. Troubleshooting

If the measurement results seem incorrect

- Refer to "7.4. Self-Inspection" to try a self-inspection.
- With the product switched to the mass display, load and unload the weight to check the repeatability of the mass value. Because a tall weight may touch the heater, use as short a weight as possible. When you have no choice but to use a 50 g weight, perform measurement with the heater cover open. Avoid disturbance such as wind when doing so. The maximum height of the weight that can be placed on the sample tray (the height from the sample tray to the glass housing) is approx. 26 mm.
- Perform the function tests to check whether the moisture content of the included test samples can be correctly measured (refer to "7.2. Test Sample Function Check").
- Is the moisture analyzer subject to any (air conditioner) wind or vibrations?
Place the product on a stable surface and ensure it is not subject to any wind or vibrations.
- Has the measurement sample been appropriately processed?
For information on cutting samples with large granules or using a glass fiber sheet, refer to "4.2. Requirements for Ensuring Correct Measurement".
- Has measurement been performed properly?
For information on preheating before measurement and replacing the tray during continuous measurement, refer to "4.2. Requirements for Ensuring Correct Measurement".

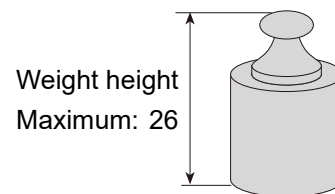

If the lamp does not light when measurement starts or it takes time to reach the set temperature



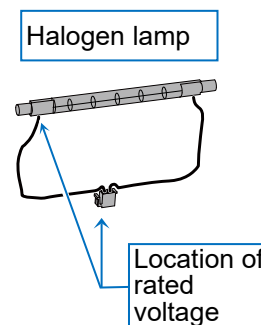





- It normally takes approx. six seconds until the lamp lights after the **START** key is pressed.
- If the heater cover is open, power is not supplied to the halogen lamp.
- The connector of the halogen lamp indicates the compatible voltage. Confirm that the rated voltage.

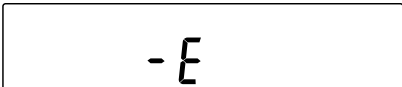

- Has the fuse blown? Remove the power plug from the power outlet, then check the fuse of the power inlet on the rear of the main unit. (Refer to "15.3. How to Replace the Power Fuse".)
- Was measurement performed at a low temperature after performing measurement at a high temperature? The lamp will not light if the temperature of the tray is higher than the set temperature.
- Confirm that the tray has sufficiently cooled before performing measurement.
- Otherwise, the halogen lamp may have expired. Check the filament of the lamp, and replace the lamp if necessary. Refer to "15.2. How to Replace the Halogen Lamp".
- If a replacement power cable is required, contact the retailer where the product was originally purchased.

- This unit features software-based temperature monitoring with automatic heating shutdown, as well as an independent non-resettable thermal fuse for final overtemperature protection. If the fuse operates, the lamp will no longer heat. Please request repair service.

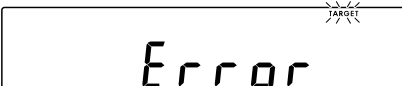
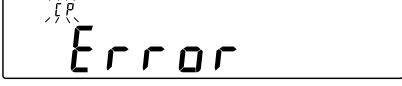
15.6. Errors Displayed

Errors displayed	Description and remedy
	<p>Overload</p> <p>The sample mass exceeded the allowed range. Reduce the sample. If this error occurs when only the sample tray is loaded, contact A&D for a repair.</p>
	<p>Underload</p> <p>The sample is too light. (The output from the mass sensor is too low.) Place the tray holder and sample tray on the product correctly, then press the RESET key.</p> <p>Perform mass sensor sensitivity adjustment.</p> <p>If the problem persists, contact A&D for a repair.</p>
	<p>AC power supply voltage error</p> <p>Check the power supply voltage. The voltage may drop if a power strip is used to share the power supply with other devices.</p>
	<p>AC power supply frequency error</p> <p>Check whether the power supply is appropriate.</p>
	<p>Insufficient sample error when heating starts</p> <p>Increase the amount of sample and perform heating.</p> <p>You can set the amount of sample to an arbitrary value. Refer to "6.4.7. Configuring the Sample Mass".</p>
	<p>Excess sample error when heating starts</p> <p>Decrease the amount of sample and perform heating.</p> <p>You can set the amount of sample to an arbitrary value. Refer to "6.4.7. Configuring the Sample Mass".</p>
	<p>Unstable measurement value</p> <p>Mass sensor sensitivity adjustment cannot be executed because the measurement value is unstable.</p> <p>Inspect the area around the tray.</p> <p>Improve the installation environment (vibrations, wind, temperature changes, electrostatic, magnetism, etc.) so that it does not affect the moisture analyzer.</p> <p>The error will automatically clear in 10 seconds.</p>
	<p>Sample mass setting value error</p> <p>The sample mass setting value is incorrect.</p> <p>Set the upper limit to a value larger than the lower limit.</p>
	<p>Comparator setting value error</p> <p>The comparator setting value is incorrect.</p> <p>Set the upper limit to a value larger than the lower limit.</p>
	<p>Self-inspection error</p> <p>A self-inspection error occurred. Request a repair.</p>

Errors displayed	Description and remedy
	Heater cover error If this error continues to be displayed, a repair is required.
	Mass sensor sensitivity adjustment weight problem (positive) The weight for mass sensor sensitivity adjustment is too heavy. Check the area around the tray. Confirm that the weight for mass sensor sensitivity adjustment is not touching the glass housing of the heater cover and that the mass of the weight for mass sensor sensitivity adjustment is appropriate. Press any key or wait 15 seconds to return to the mass display.
	Mass sensor sensitivity adjustment weight problem (negative) The weight for mass sensor sensitivity adjustment is too light. Check the area around the tray. Confirm that the mass of the weight for mass sensor sensitivity adjustment is appropriate. Press any key or wait 15 seconds to return to the mass display.
	Heating temperature adjustment data input timeout Indicates that there was no temperature input after waiting for five minutes when adjusting the heating temperature. Press any key to clear the error. To adjust the heating temperature, repeat the procedure from the start.
	Full memory The number of results recorded with the data memory function reached the upper limit. Existing results must be erased to record new results. Refer to " 10. Data Memory Function ".
	Internal clock battery error Press any key, then enter the date and time. Refer to " 8.4. Checking and Configuring the Date/Time ". If the problem persists, request a repair.
	Internal clock malfunction Request a repair.
	Internal error Turn the power OFF then ON again. If the error occurs again, request a repair.
 	IC error Request a repair.
	Temperature control error Try again after turning the power OFF and waiting for at least 30 minutes. If the error occurs again, request a repair.

16. Disposal

Due to the requirements of the European Directive on Waste Electrical and Electronic Equipment (WEEE) 2012/19/EU, the product must not be disposed of as general waste. Follow the local laws when disposing of the product.

Dispose of the product according to the local regulations on recycling electrical and electronic devices. If you have any questions, contact the relevant local government office. Make sure to convey these disposal requirements if transferring the product to a new owner.

17. Specifications

			MS-74A	MX-53A	MF-53A	ML-53A
Heating method			400 W halogen lamp			
Range of sample tray temperature settings			30°C to 200°C (1°C increments)			
Sample tray heating patterns			Standard heating, ramp heating, step heating, quick heating			
Heating temperature adjustment			Available with separate temperature adjustment kit (AX-MXA-43; sold separately)			
Measurable sample mass			0.1 g to 71 g	0.1 g to 51 g		
Minimum displayed	Moisture content		0.001%, 0.01%, 0.1%	0.01%, 0.1%	0.05%, 0.1%, 1%	0.1%, 1%
	Weight		0.0001 g	0.001 g	0.002 g	0.005 g
Measurement accuracy Reproducibility Standard deviation	Moisture content ^{*1}	Sample mass 5 g or more	0.01%	0.02%	0.05%	0.1%
		Sample mass 1 g or more	0.05%	0.1%	0.2%	0.5%
	Weight		0.0002 g	0.001 g	0.002 g	0.005 g
Measurement conditions	Measurement mode	Standard mode	The sample mass and termination value ^{*2} are automatically determined according to the measurement accuracy, then measurement stops when the termination value is reached.			
		Timer mode	Measures moisture content by heating for a certain period of time. (1 to 480 min)			
		Custom mode	Enables the user to configure detailed measurement conditions. Measurement ends when the set termination value ^{*2} is reached.			
	Measurement basis		Moisture content (standard before heating), moisture content (Atro, standard after heating), solids, ratio, grams			
	Recordable measurement conditions		200 sets			
Recordable measurement results (data memory function)			200			
Interfaces	RS-232C		9-pin D-Sub (male) EIA RS-232C			
	USB		Type-C (female) USB 2.0 HID CDC			
Sample tray dimensions			φ90 mm			
Operating temperature and humidity			5°C to 40°C; Humidity: 85% or lower RH (without condensation)			
Usage range			Indoor use only			
Elevation			Maximum: 2000 m			
Power supply			120 V AC Version 240 V AC Version Voltage fluctuations Power load	100 V to 120 V, 50/60 Hz, 3A ^{*4} 200 V to 240 V, 50/60 Hz, 1.5A -15%, +10% Approximately 500 W ^{*3}		
Overvoltage category			II			
Pollution level			2			
Maximum power consumption			500 W			
External Dimensions			215 (W) × 380 (D) × 176 (H)			

	MS-74A	MX-53A	MF-53A	ML-53A
Main unit weight	Approx. 6 kg (excluding accessories)			

- *1 The result of performing preheating then measuring the included test sample (approx. 5 g of sodium tartrate dihydrate) at 160°C with standard heating and the standard mode () and cooling for 15 minutes at room temperature with the heater cover raised after each measurement.
- *2 Measurement stops when the time change of the moisture content is at or below the set value.
- *3 Please confirm that this analyzer is compatible with your local voltage, receptacle type, and power cable.
- *4 UL certified products are 120 V Version only.

List of Included Accessories

Yes Included as standard; - Available for purchase

	MS-74A	MX-53A	MF-53A	ML-53A
Tray holder	Yes	Yes	Yes	Yes
Breeze break	Yes	Yes	Yes	Yes
Display protective cover	Yes	Yes	Yes	Yes
Power cable	Yes	Yes	Yes	Yes
Quick Start Guide	Yes	Yes	Yes	Yes
Warranty card	Yes	Yes	Yes	Yes
Body cover	Yes	Yes	-	-
Test sample ^{*1}	Yes	Yes	-	-
Glass fiber sheet	×100	×100	-	-
Spoon	Yes	Yes	-	-
Tweezers	Yes	Yes	-	-
USB cable	Yes ^{*2}	Yes ^{*2}	-	-
Sample tray	× 20	× 20	× 10	× 10
Sample tray handle	× 2	× 2	× 1	× 1
Disposable aluminum tray	× 100	× 100	× 100	× 100

Yes: Included; -: Not included

*1 30 g of sodium tartrate dihydrate

*2 UL certified products do not include a USB cable.

17.1. External Dimensions

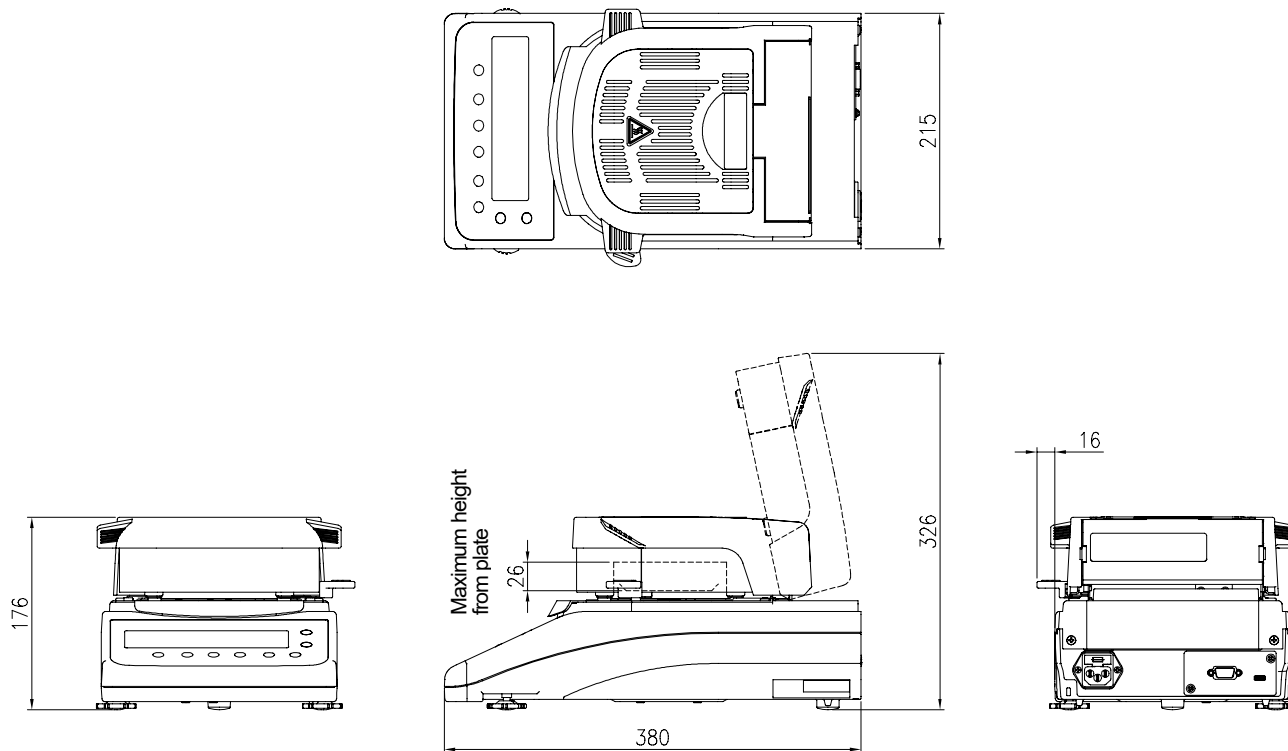

Unit: mm

18. Accessories (Sold Separately)

Accessory

Name	Number
Disposable aluminum tray (φ90 mm, set of 100)	AX-MXA-30
Sample tray (φ90 mm, set of 100)	AX-MXA-31
Glass fiber sheet φ70 mm (filter paper, set of 100) Use for liquid samples with high surface tension.	AX-MX-32-1
Glass fiber sheet φ86 mm (glass paper, set of 100) The same as that included with the MS-74A and MX-53A. Use for liquid samples.	AX-MXA-32-2
Test samples (sodium tartrate dihydrate; 30 g × 12 sets)	AX-MX-33
Halogen lamp (100 V to 120 V)	AX-MX-34-120V
Halogen lamp (200 V to 240 V)	AX-MX-34-240V *1
Sample tray handle (set of two)	AX-MXA-35
Tweezers (set of two)	AX-MX-36
Spoon (set of two)	AX-MX-37
Display protective cover (set of five)	AX-MXA-38
Body cover	AX-MXA-39
Mass sensor sensitivity adjustment weight (20 g; OIML F1 class accuracy)	AD1603-20F1
Temperature adjustment kit (with calibration certificate)	AX-MXA-43
Fuse (T6.3 A 250 V)	AX-FST6.3A250V

*1 UL certified products are 120 V Version only.

List of Accessories Available Separately

AD-8129TH: Thermal printer

- Multifunctional
- Statistical computation, calendar/clock function, interval print function (prints at a certain interval from 5 sec to 30 min), chart print function (prints the specified two digits in graph format), dump print mode
- 13 × 28 dots; 24 characters per line
- Thermal paper AX-PP147-S (57.5 mm (W) × approx. 30 m)
Dust-free thermal paper AX-PP183-S (57 mm (W) × approx. 25 m)

AD-1687: Environment logger

- Four environment sensors (temperature, humidity, air pressure, and vibration) are included to enable simultaneous measurement and recording with standalone operation. By connecting with the RS-232C output of the moisture analyzer, the mass value can be recorded together with the environment data. Dedicated data importing software is not required.

AD-1688: Measurement data logger

- Enables data output from the RS-232C port to be recorded. This enables mass and moisture content values to be saved in environments where a computer cannot be used. Dedicated data importing software is not required.

AD-8526: Ethernet converter

- Enables management of measurement values using an Ethernet network, via a LAN port and the RS-232C port of a measurement device.
- Includes “WinCT-Plus” data communication software

AX-USB-9P: USB converter

- Enables serial communication software such as “WinCT” to be used with a USB connection, even on a computer without a COM port. Bidirectional communication can be performed after the driver is installed.

AX-KO2741-180: 1.8 m RS-232C cable (9-pin D-Sub (female) to 9-pin D-Sub (female))

- A cable for connecting the moisture analyzer to a PLC, etc.

AX-KO7919-200: 2 m USB cable (Type-A to Type-C)

- The USB cable included with the moisture analyzer as standard. ^{*1}
^{*1} UL certified products do not include a USB cable.

AD-1683A: Ionizer

- Prevents measurement error caused by static electricity during measurement via static elimination. Optimal for precise measurement of samples such as powders because it is a direct flow-type ionizer that does not emit wind.
- It is compact and lightweight.

AD-1684A: Non-contact electrostatic measuring instrument

- Displays the result of measuring the charge (of an automatic measurement line, etc.) of moisture analyzer peripherals such as the measured sample, tare, or breeze break. AD-1683A (static eliminator) can be used to remove an electrostatic charge from the product.

AD-1689: Tweezers for analysis operations

- Tweezers for retaining the 1 g to 500 g weight used for the mass sensor sensitivity adjustment of the moisture analyzer.
- The tweezers are 210 mm long and feature a cap on the end.

AX-TWEEZERS-25: Tweezers for analysis operations

- Tweezers for retaining the 1 g to 500 g weight used for the mass sensor sensitivity adjustment of the moisture analyzer.
- The end features a cap made of polycarbonate + 10% carbon + 10% glass fiber materials, which makes it less susceptible to electrostatic.

AD-1603-20F1: Mass sensor sensitivity adjustment weight

- A 20 g OIML shape F1 class weight.

AD-8541-PC: Bluetooth® dongle for connecting a computer

- ❑ Enables bidirectional communication between the AD-8541-SCALE and a computer via the COM port using Bluetooth.

Maximum communication distance: Approx. 10 m

(For details, refer to "AD-8541-PC Instruction Manual".)

AD-8541-SCALE: Bluetooth® converter for connecting a scale

- ❑ Enables wireless communication via Bluetooth with a Bluetooth device such as a smartphone/tablet, computer, external Bluetooth display, or the AD-8931-JA or AD-8541-PC.

Maximum communication distance: Approx. 10 m

(For details, refer to "AD-8541-SCALE Instruction Manual".)

[This page intentionally left blank]



A&D Company, Limited

3-23-14 Higashi-Ikebukuro, Toshima-ku, Tokyo 170-0013, JAPAN
Telephone: [81] (3) 5391-6132 Fax: [81] (3) 5391-1566

A&D ENGINEERING, INC.

Headquarters Office: 4622 Runway Boulevard, Ann Arbor, Michigan 48108, U.S.A.
Sales Office: 47747 Warm Springs Boulevard, Fremont, California 94539, U.S.A.
Tel: [1] (800) 726-3364 Weighing Support: [1] (888) 726-5931 Inspection Support: [1] (855) 332-8815

A&D INSTRUMENTS LIMITED

Unit 24/26 Blacklands Way, Abingdon Business Park, Abingdon, Oxfordshire OX14 1DY United Kingdom
Telephone: [44] (1235) 550420 Fax: [44] (1235) 550485

A&D AUSTRALASIA PTY LTD

32 Dew Street, Thebarton, South Australia 5031, AUSTRALIA
Telephone: [61] (8) 8301-8100 Fax: [61] (8) 8352-7409

A&D KOREA Limited

한국에이.엔.디(주)
서울특별시 영등포구 국제금융로6길33 (여의도동) 맨하탄빌딩 817 우편 번호 07331
(817, Manhattan Bldg., 33. Gukjegeumyung-ro 6-gil, Yeongdeungpo-gu, Seoul, 07331 Korea)
전화: [82] (2) 780-4101 팩스: [82] (2) 782-4264

ООО A&D RUS

ООО "Эй энд Ди Рус"
Почтовый адрес: 121357, Российская Федерация, г.Москва, ул. Вереysкая, дом 17
Юридический адрес: 117556 г. Москва, Варшавское шоссе, д. 95, корп. 1.
тел.: [7] (495) 937-33-44 факс: [7] (495) 937-55-66

A&D Instruments India Private Limited

ऐ&डी इन्सट्रुमेंट्स इण्डिया प्रा० लिमिटेड
D-48, उद्योग विहार , फेस -5, गुरगांव - 122016, हरियाणा , भारत
(D-48, Udyog Vihar, Phase-V, Gurgaon - 122016, Haryana, India)
फोन : [91] (124) 4715555 फैक्स : [91] (124) 4715599

A&D SCIENTECH TAIWAN LIMITED.

艾安得股份有限公司
台湾台北市中山區南京東路2段206號11樓之2
(11F-2, No.206, Sec.2, Nanjing E.Rd., Zhongshan Dist., Taipei City 10489, Taiwan, R.O.C.)
Tel : [886](02) 2322-4722 Fax : [886](02) 2392-1794

A&D INSTRUMENTS (THAILAND) LIMITED

บริษัท เอ แอนด์ ดี อินสตรูमेंท์ (ไทยแลนด์) จำกัด
168/16 หมู่ที่ 1 ตำบลรังสิต อำเภอธัญบุรี จังหวัดปทุมธานี 12110 ประเทศไทย
(168/16 Moo 1, Rangsit, Thanyaburi, Pathumthani 12110 Thailand)
Tel : [66] 20038911