

AD-4408A

Weighing Indicator
for Field Networks





INSTRUCTION MANUAL



1WMPD4001973A

WARNING DEFINITIONS

The warnings described in this manual have the following meanings:

 WARNING	A potentially hazardous situation which, if not avoided, could result in death or serious injury.
 CAUTION	A potentially hazardous situation which, if not avoided, may result in minor or moderate injury or damage to the instrument.
	This symbol indicates caution against electrical shock. Do not touch the part where the symbol is placed.
	This symbol indicates the ground terminal.
	This symbol indicates that an operation is prohibited.
NOTE	Information or cautions to use the device correctly.

© 2012 A&D Company, Limited. All rights reserved.

No part of this publication may be reproduced, transmitted, transcribed, or translated into any language in any form by any means without the written permission of A&D Company, Limited.

The contents of this manual and the specifications of the instrument covered by this manual are subject to change for improvement without notice.

Anybus-CompactCom is a registered trademark of HMS Industrial Networks.



Contents

1.	Safety Precautions.....	2
2.	Introduction.....	3
3.	Specifications	4
3.1.	Analog Section	4
3.2.	Digital Section	4
3.3.	General	5
4.	Description of Each Part.....	7
4.1.	Front Panel	7
4.2.	Rear Panel	9
5.	Installation	10
5.1.	Precautions	10
5.2.	Load Cell Cable Type.....	11
5.3.	Shield Connection	11
5.4.	Load Cell Connection.....	12
5.5.	Checking the Load Cell Connection	13
5.6.	Interface Module Installation	14
6.	Operation.....	15
6.1.	General Function.....	15
6.2.	Mode Map	18
7.	Calibration	19
7.1.	General Description	19
7.2.	Calibration With an Actual Load (<i>CAL SET</i>).....	20
7.3.	Calibration-Related Functions (<i>CAL F</i>).....	22
7.4.	Calibration Errors	28
7.5.	Load Cell Output Adjustment	29
8.	General Functions	30
8.1.	Setting Procedure	30
8.2.	Adjusting the Digital Filter	31
8.3.	Basic Functions (<i>FUNC F</i>)	32
8.4.	Standard Serial Output (<i>LS F</i>)	33
9.	Interface.....	34
9.1.	Standard Serial Output.....	34
10.	Maintenance	37
10.1.	Error Messages.....	37
10.2.	Check Mode.....	37
10.3.	Initialization Mode	41
10.4.	Checking the Load Cell Connection Using the Digital Multimeter	43
11.	Setting List.....	45
11.1.	Basic Functions.....	45
11.2.	Standard Serial Output.....	46
11.3.	Calibration-Related Functions	47
12.	External Dimensions.....	49



1. Safety Precautions

For safe and correct usage, read the following precautions carefully before using the indicator.

Grounding

Earth ground the indicator by connecting the earth ground terminal  located on the rear panel to the earth, to prevent a fire, electrical shock or indicator malfunction.

Do not share the ground line with other electrical power equipment.

Appropriate power cable

Use a power cable appropriate to the supply voltage and current used. Using an inappropriate cable may cause electrical leakage or a fire.

Connect the power cable to the terminals firmly using compression lugs.

Fuse replacement

A fuse is provided to protect against a short circuit and possible fire hazard.

The indicator is equipped with various protection circuits and the fuse should not burn out under normal operations.

If the fuse burns out, the internal circuits may have been damaged by surges. Do not try to replace the fuse. Contact the nearest A&D dealer.

Avoid water and moisture

The indicator is not water-resistant.

Securing the front panel to the control panel using the accessory panel mount packing will provide the indicator with IP-65 protection.

Avoid an environment with flammable gases

Do not use the indicator in places where flammable gases are present.

Indicator overheat

To prevent the indicator from overheating, allow appropriate clearance between the peripheral devices.

If the ambient temperature exceeds the specified operating temperature, use a fan to cool the environment.



2. Introduction

- The AD-4408A is a weighing indicator that amplifies signals from a load cell, converts it to digital data and displays it as a weight value.
- Connection to various field networks is possible by installing the interface module into the option slot.
 - For details on applicable field networks, visit our website.
 - Download the instruction manual for each interface from our website. (Memory map and check modes vary with the interface.)
 - The interface module used is the Anybus-CompactCom network interface module, manufactured by HMS Industrial Networks.
 - The interface module is available as an accessory for the AD-4408A. Purchase the interface module from A&D, or directly from an interface module supplier.
- The accessory panel mount packing will provide the indicator with IP-65 protection.
- This indicator has the following performance:
 - Input sensitivity: 0.15 $\mu\text{V}/\text{d}$
 - Display resolution: 999,999 d max.
 - Sampling rate:..... 100 times/second
 - Input voltage range: -35 mV to +35 mV (-7 mV/V to +7 mV/V)
- Digital span mode:

Keying in the load cell output voltage (mV/V) allows calibration to be performed without an actual load.

NOTE: The unit, d indicates a minimum division.



3. Specifications

3.1. Analog Section

Input sensitivity	0.15 $\mu\text{V}/\text{d}$ or greater	
Input voltage range	-35 mV to +35 mV (-7 mV/V to +7 mV/V)	
Zero adjustment range	-35 mV to +35 mV (-7 mV/V to +7 mV/V)	
Load cell excitation voltage	5VDC $\pm 5\%$, 120 mA with remote sensing capability	
Load cell drive capacity	Maximum 8 x 350 Ω load cells	
Temperature coefficient	Zero	$\pm 0.02 \mu\text{V}/^\circ\text{C}$ typ., $\pm 0.1 \mu\text{V}/^\circ\text{C}$ max.
	Span	$\pm 3\text{ppm}/^\circ\text{C}$ typ., $\pm 15\text{ppm}/^\circ\text{C}$ max.
Non-linearity	0.005 % of full scale	
A/D conversion method	Delta-sigma method	
A/D resolution count	Approximately 16,000,000 counts	
Display resolution	999,999 d max.	
Sampling rate	100 times/second	

3.2. Digital Section

Display element	<ul style="list-style-type: none">• Measurement display: 6-digit 7-segment green LED• Character height: 14.6 mm• Polarity display: 1 green LED• Status indicators: 6 red LEDs
Measurement display	<ul style="list-style-type: none">• Switches between NET and GROSS• Selectable decimal places (10^1, 10^2, 10^3, 10^4, 10^5)• Overflow display All the digits turn OFF. (When the polarity is negative, the minus sign appears at the highest-order digit.)
Status indicators	ZERO, STABLE, GROSS, NET, HOLD, \square
Key switches	ZERO, TARE, NET/GROSS, F, ON/OFF, ENTER, CAL

3.3. General

3.3.1. Interface

Standard serial output	Output for communication with A&D peripheral devices (20 mA current loop)
Option slot	Connection to various field networks is possible by installing the interface module into the option slot. For details on applicable field networks, visit our website.

3.3.2. Measuring functions

Zero adjustment	<ul style="list-style-type: none">• Sets the gross weight to zero by pressing the ZERO key.• Selection of disable or enable for the operation when unstable.• The zero value is stored in the non-volatile memory.• Zero adjustable range Can be set optionally in the range of 1 to 100% of the weighing capacity.
Zero tracking	<ul style="list-style-type: none">• Tracks the weight drift around the zero point to maintain zero.• Zero tracking time 0.0 to 5.0 seconds (Can be set optionally within the range.)• Zero tracking band 0.0 to 9.9 d (Can be set optionally within the range.)
Tare	<ul style="list-style-type: none">• Sets the net weight to zero by pressing the TARE key.• Selection of disable or enable for the operation when unstable or negative.• The tare weight is stored in the non-volatile memory.• Tare range: Gross weight \leq Weighing capacity
Stability detection	<ul style="list-style-type: none">• Turns ON the stabilization indicator when the variables of the weight values per sampling are within the set band in the set time.• Stability detection time 0.0 to 9.9 seconds (Can be set optionally within the range.)• Stability detection band 0 to 9 d (Can be set optionally within the range.)
Digital filter	Cutoff frequency range (-3dB) : 0.07 to 11 Hz

3.3.3. Other

Data backup against power failures	<ul style="list-style-type: none">• Zero value, tare weight, calibration data and function data are written into the FRAM.• Data retention time is 10 years or more.
Power source	100 VAC to 240 VAC, +10%, -15%, (50/60 Hz)
Power consumption	Approximately 10 VA
Operating temperature	-10°C to +40°C
Operating humidity	85% R.H. or less (no condensation)
Installation method	Panel mount
Mass	Approximately 800 g

3.3.4. Accessories

Item	Quantity	Model name
Weighing capacity plate	1	108-4023454
Unit label	1	108-4023456
Panel mount packing	1	106-4004213
Terminal block cover	1	107-4005384



4. Description of Each Part

4.1. Front Panel

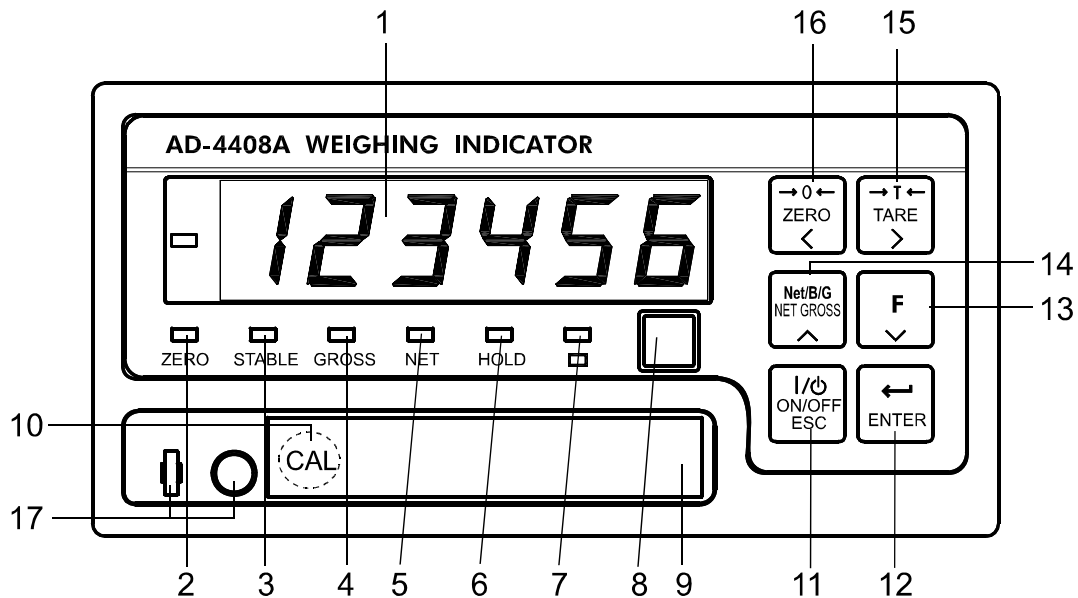









Fig.1 Front panel

Displays

No.	Name	Description
1	Main display	Displays the weight value, setting values, error messages, etc.
2	ZERO	Turns ON when the weight value is in the center of zero.
3	STABLE	<ul style="list-style-type: none"> • Turns ON when the weight value is stable. • The stability conditions can be changed in the calibration-related functions.
4	GROSS	Turns ON when the displayed value is a gross weight.
5	NET	Turns ON when the displayed value is a net weight.
6	HOLD	<ul style="list-style-type: none"> • Turns ON when the weight value is being held. • Two hold modes can be selected in the general functions, either normal hold or peak hold.
7		The function for this indicator can be selected in the general functions, depending on the purpose.
8	UNIT	<ul style="list-style-type: none"> • Place a unit label. • A unit used for weighing is set in the calibration-related functions.
9	Capacity plate	Place a weighing capacity plate.

Key switches

No.	Name	Description
10	CAL	<ul style="list-style-type: none"> • The key to enter the calibration mode. • The key is concealed by a sealable cover. To avoid unintentional operations, keep the cover attached except when entering the calibration mode.
11		<ul style="list-style-type: none"> • The key to turn the indicator ON (Weighing mode) and OFF (OFF mode). • To turn the indicator OFF (OFF mode), press and hold the key for three seconds or more. • When OFF, all of the displays and external output/input devices are turned OFF, but a decimal point located at the right side of the main display remains ON. • The key functions as an ESC key when the numerical values are being entered.
12		<ul style="list-style-type: none"> • The key to proceed to the selected mode. • Confirms the setting value and stores the data when pressed after a setting is changed.
13		<ul style="list-style-type: none"> • The function for this key can be selected in the general functions, from the list below: <ul style="list-style-type: none"> None Manual print command Hold Alternate switch Momentary switch Clear the tare weight Clear the zero value • The key decreases the value of the blinking digit by one when the numerical values are being entered.
14		<ul style="list-style-type: none"> • The key to switch between the gross weight and the net weight. • The key increases the value of the blinking digit by one when the numerical values are being entered.
15		<ul style="list-style-type: none"> • The key to perform tare. • The tare conditions are set in the calibration-related functions. • The key shifts the position of the blinking digit to the right when the numerical values are being entered. • In the OFF mode, pressing the ON/OFF key while holding down the TARE key will clear the zero value and the tare weight.
16		<ul style="list-style-type: none"> • The key to zero the current display. • The zero conditions are set in the calibration-related functions. • The key shifts the position of the blinking digit to the left when the numerical values are being entered.
17	Seal	<ul style="list-style-type: none"> • Can be sealed using a wire seal.

4.2. Rear Panel

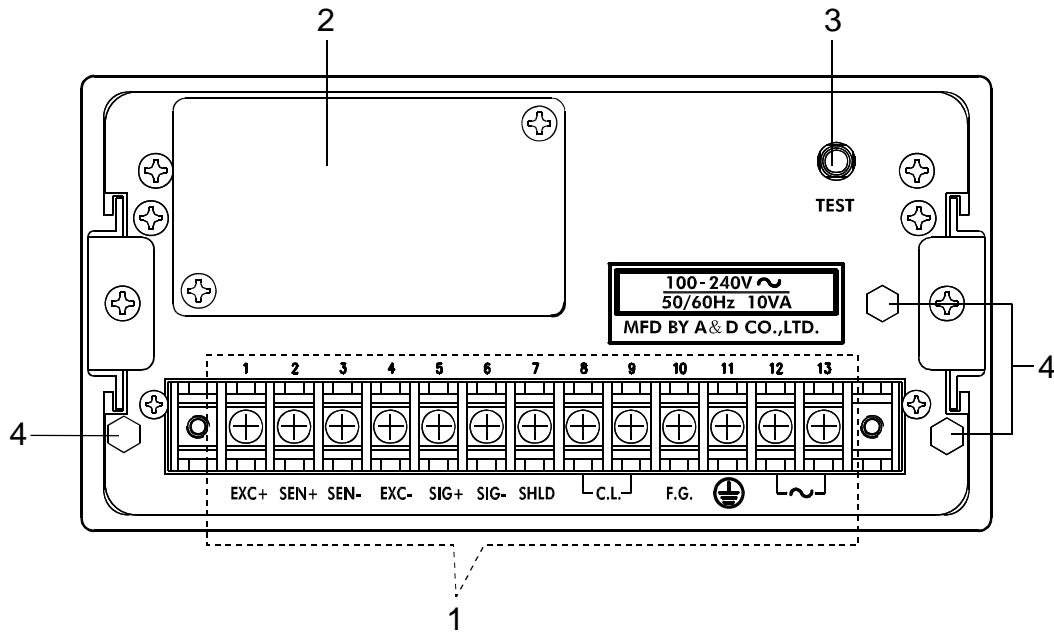

Fig.2 Rear panel

1 Terminal block

Terminal No.	Function	
1	EXC+	Load cell excitation voltage (+)
2	SEN+	Sensing input (+)
3	SEN-	Sensing input (-)
4	EXC-	Load cell excitation voltage (-)
5	SIG+	Load cell input (+)
6	SIG-	Load cell input (-)
7	SHLD	Shield
8	C.L.	Standard serial output (Current loop)
9	C.L.	Standard serial output (Current loop)
10	F.G.	Frame ground
11	⊕	Earth ground
12	~	AC power source
13	~	AC power source

NOTE: Terminals 7 (SHLD) and 11 (E) are internally connected.

To avoid unintentional operations, keep the cover attached on the terminal block.

Screw size: M3, tightening torque: 0.5N·m

2 Blank panel

Option slot inside to install the interface module.

3 Testing terminal

Do not use, leave this terminal unconnected.

4 Sealing bolts

Can be sealed with a wire seal.



5. Installation

⚠ CAUTION

The weighing indicator is a precision electronic instrument. Handle it carefully.

5.1. Precautions

5.1.1. Environment

- The operating temperature is -10°C to $+40^{\circ}\text{C}$.
- Do not install the indicator in direct sunlight.
- The indicator is not water-resistant. When used in an environment where the indicator may be exposed to splashing water, secure the front panel to the control panel using the accessory panel mount packing. It makes the front panel water-resistant equivalent to IP-65.

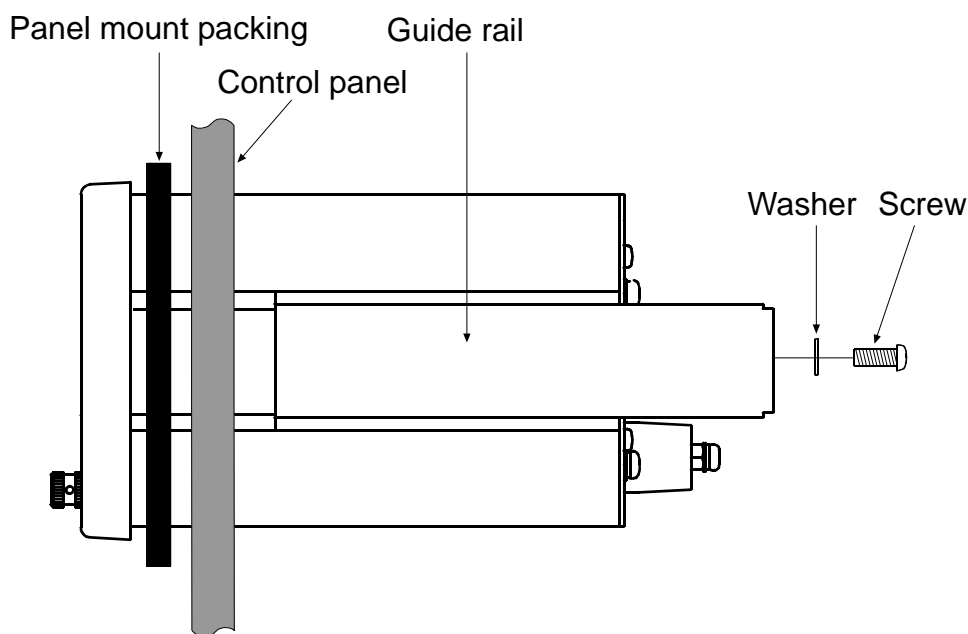

Fig.3 Panel mounting method

5.1.2. Power source



Earth ground the indicator to prevent electrical shock or indicator malfunction.

- Before connecting the indicator to the power source, read the instruction manual thoroughly.
- Do not connect the indicator to the power source before the installation is complete.
- ⚠ □ To avoid electrical shock, do not handle the power cable with a wet hand.
- ⚠ □ Earth ground the indicator. Do not share the ground line with other electrical power equipment.
- The power requirement is 100 VAC to 240 VAC and the frequency is 50 Hz or 60 Hz. Use a stable power source free from instantaneous power failure or noise.
- To avoid a malfunction, do not share the power line with other devices.
- The output voltage of a load cell is a very sensitive signal. Keep all electrical noise sources away from the load cell and load cell cable.
- Use shielded I/O cables. Connect the cable shield to the F.G. terminal or the indicator housing.

5.2. Load Cell Cable Type

Load cell cables should have high insulation and shielding performance.

Use shielded cables with the insulator that is made of materials with high insulation resistance such as Teflon[®] and polyethylene.

NOTE: Teflon is a registered trademark of DuPont.

5.3. Shield Connection

Connect the load cell shield wire only to the shield terminal (terminal 7 of the terminal block located on the rear panel) of the AD-4408A.

No ground is connected between the load cell and the AD-4408A. This is to prevent the ground loop generated by multiple ground points. Ground loop can be a major cause of noise and interference.

5.4. Load Cell Connection

Two types of load cell connection are available: 6-wire connection and 4-wire connection.

For high precision and stable weighing, 6-wire connection is recommended.

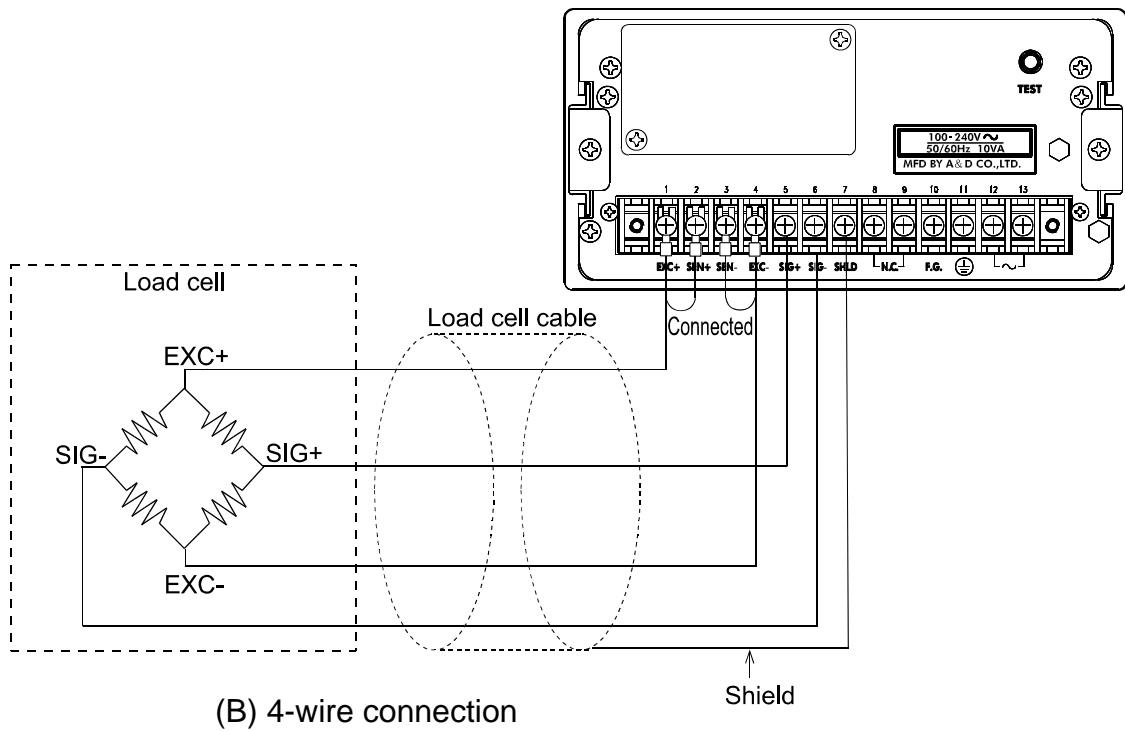
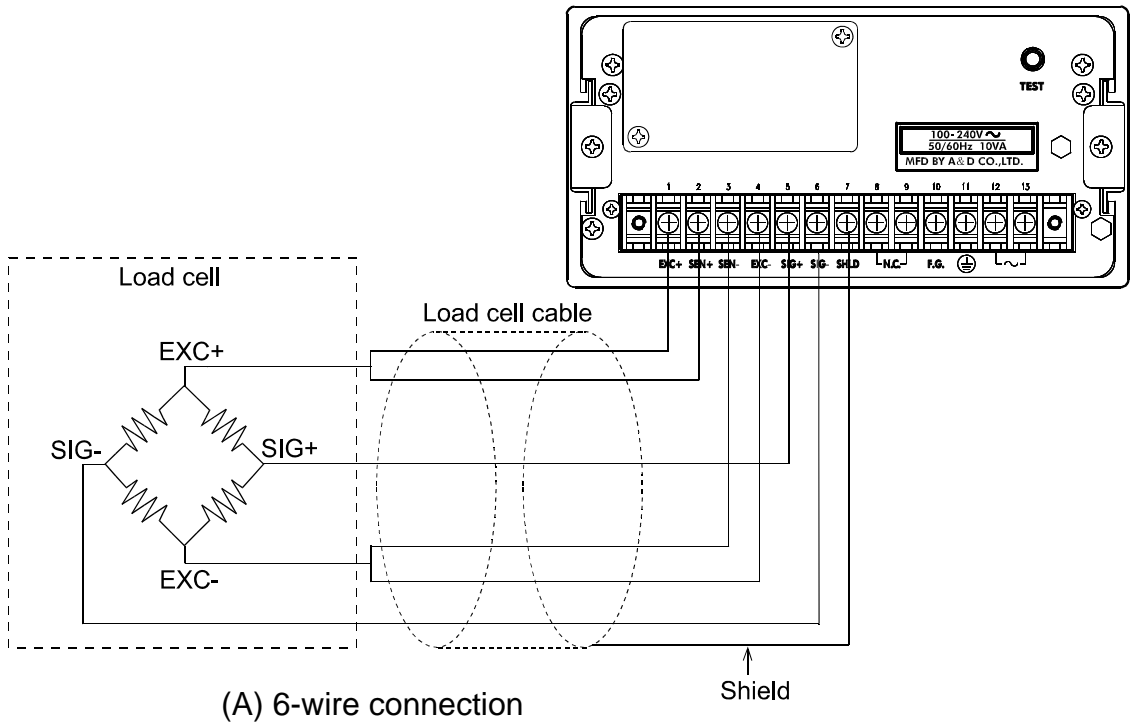

Fig.4 Load cell connection

Type	Advantages	Disadvantages	Description
6-wire connection (recommended)	The error is small even when the load cell cable is extended, a thin load cell cable is used, or multiple load cells are used.	Complicated wiring	Use a 6-wire shielded cable when a summing box is used.
4-wire connection	Simple wiring	The influence of the load cell cable resistance worsens the temperature coefficient. Prone to the influence of the contact resistance of the connector	The error increases when the load cell cable is extended or multiple load cells are used.

Precautions on performing the 4-wire connection

- Be sure to connect terminals 1 and 2 (EXC+ and SEN+) and terminals 3 and 4 (SEN- and EXC-).
- If the cable needs extending, use a cable with as large a cross-sectional area as possible or keep the cable as short as possible.

5.5. Checking the Load Cell Connection

When the load cell connection is complete, follow the procedure below to check the connection.

Step 1 Perform a visual check to ensure that the wiring is correct.

Step 2 Turn the AD-4408A ON.

All the digits may be OFF before calibration. Even under such a condition, the check mode can be used.

Step 3 Enter the check mode and check the load cell output value.

Refer to “10.2.1. Entering the check mode” to enter the A/D check mode.

Step 4 Confirm that the displayed load cell output value matches the specified value.

Normally the displayed value will be the load cell rated output value or less.

Step 5 If an error occurs, refer to “10.4. Checking the Load Cell Connection Using the Digital Multimeter” to check the connection.

5.6. Interface Module Installation

⚠ CAUTION

Be sure to disconnect the AD-4408A from the power source before installing the interface module.

Install the interface module as follows:

Step 1 Using a Phillips screwdriver, loosen the screws that secure the blank panel to the AD-4408A rear panel, and remove the blank panel.

Step 2 Insert the interface module into the option slot as shown to the right.

Step 3 Insert the interface module until it mates with the terminals of the PC board connector located in the option slot.

Step 4 Using a TORX® driver (size T9), fasten the retaining screws with a tightening torque of 0.25 N·m in the clockwise direction to secure the interface module.

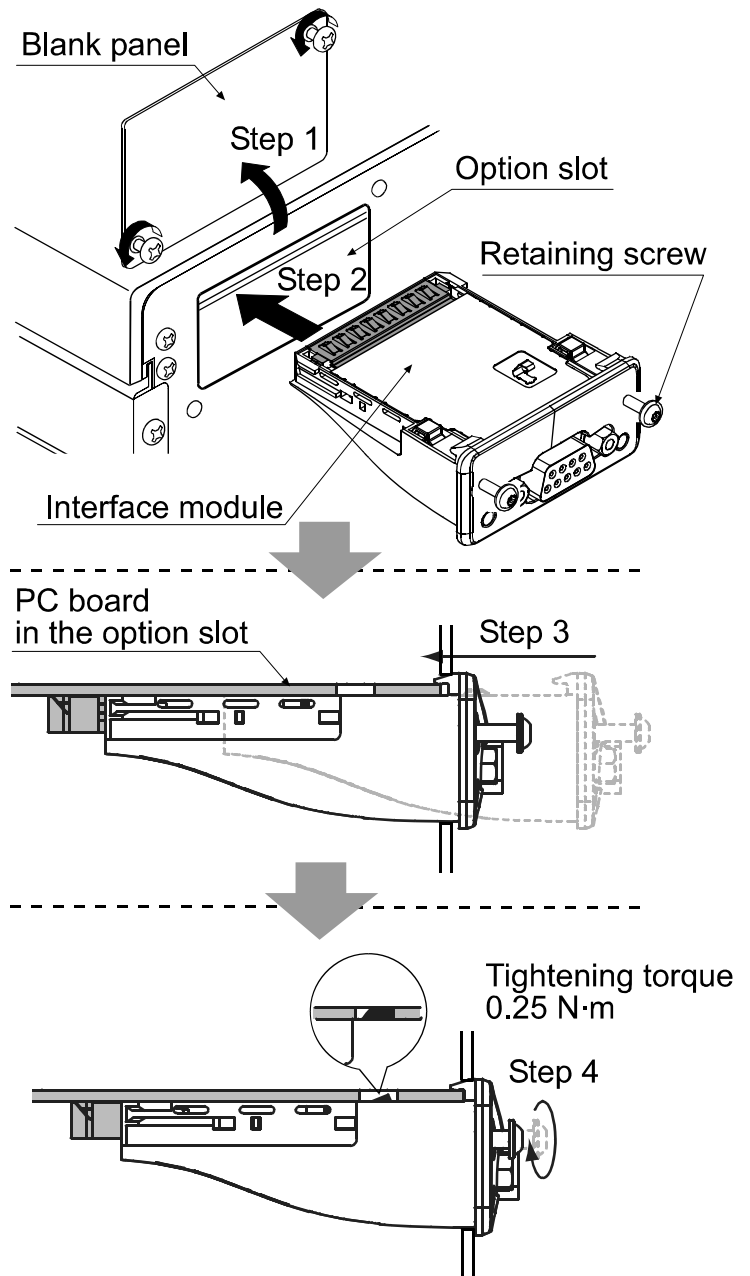

Fig.5 Interface module installation

**NOTE: A TORX® driver is not provided with the AD-4408A.
TORX is a registered trademark of Textron Inc.**



6. Operation

6.1. General Function

6.1.1. Zero adjustment

- Zero adjustment is a function to set the gross weight to zero. It is performed by pressing the ZERO key.
- The zero adjustment range is set in *[ALF05]* (zero adjustment range) and is expressed in percent of the weighing capacity with the calibration zero point as the center.
- Zero adjustment is disabled, even within the zero adjustment range, when the A/D converter overflow occurs.
- A ZERO error is output if zero adjustment is not performed.
- The zero value is stored in the non-volatile memory and is maintained, even if the power is disconnected.
- Clearing the zero value is performed using the F key assigned to clear the zero value. Alternately, apply power to the indicator while holding down the TARE key, or with the indicator in the OFF mode, press and hold the TARE key and press the ON/OFF key, to clear the zero value.

Functions related to zero adjustment

- *[ALF05]*: Changes the zero adjustment range. (0 to 100%)
- *[ALF10]*: Enables or disables zero adjustment when unstable.
- *[ALF16]*: Enables or disables power-ON zero (function to zero upon power-ON).

6.1.2. Zero tracking

- Zero tracking is a function to track the weight drift around the zero point to maintain zero.
- The zero tracking time is set in *[ALF06]* (zero tracking time) and the zero tracking band is set in *[ALF07]* (zero tracking band). When the weight drift is within the specified ranges, zero adjustment is performed automatically.
- A ZERO error is not output even if zero tracking is not performed.

Functions related to zero tracking

- *[ALF06]*: Changes the zero tracking time. (0.0 to 5.0 seconds)
- *[ALF07]*: Changes the zero tracking band. (0.0 to 9.9 d)

6.1.3. Tare

- Tare is a function to store the gross weight as the tare value and set the net weight to zero.
- The tare weight is stored in the non-volatile memory and is maintained, even if the power is disconnected.
- Clearing the tare weight is performed using the F key assigned to clear the tare weight. Alternately, apply power to the indicator while holding down the TARE key, or with the indicator in the OFF mode, press and hold the TARE key and press the ON/OFF key, to clear the tare weight.

Functions related to tare

- *ALF 10*: Enables or disables tare when unstable.
- *ALF 11*: Enables or disables tare when the gross weight is negative.

6.1.4. F key

- Assign a function to the F key in the general functions.

Functions related to the F key

- *FncF02*: Assigns a function to the F key from the functions below:

0: None

1: Manual print command

2: Hold

3: Alternate switch (Read the description below.)

4: Momentary switch (Read the description below.)

5: Clear the tare weight

6: Clear the zero value

- *ALF 15*: Enables or disables clearing the zero value.
- *ALF 20*: Enables or disables the print command when the gross weight is negative.

Alternate switch and momentary switch

- By assigning these switches to the F key, the ON/OFF status of the F key can be transmitted to the master station. This is useful when building a network or performing maintenance.
- By selecting “3: F key status” for *FncF04* (□ display), the ON/OFF status of the F key can be confirmed by the memory in sync with the □ display.
- These switches perform as below:

Alternate switch

Press the switch once and release the switch to turn ON or OFF.

Press the switch again to turn OFF or ON.

Momentary switch

Only when the switch is being pressed, the F key is ON. When released, OFF.

6.1.5. □ display

- Assign a function to the □ display in the general functions.

Functions related to the □ display

● *FncF04*: Assigns a function to the □ display from the functions below:

0: None

1: Zero tracking in progress

2: Alarm (Zero range setting error, over)

3: F key status (Read the description below.)

F key status

- Enables when alternate switch or momentary switch is selected for *FncF02* (F key).
The □ display turns ON when the F key is ON and turns OFF when the F key is OFF.

6.1.6. Memory backup

Zero value, tare weight, calibration data and function data are written into the FRAM. FRAM is a non-volatile memory and does not require batteries.

Data retention time is 10 years.

6.2. Mode Map

The indicator has several modes to perform various operations.

Perform mode switching by key operation as shown below, only in the direction of the solid arrow.

After setting a mode, the indicator resets automatically. Alternately, the indicator resets, when the power is disconnected.

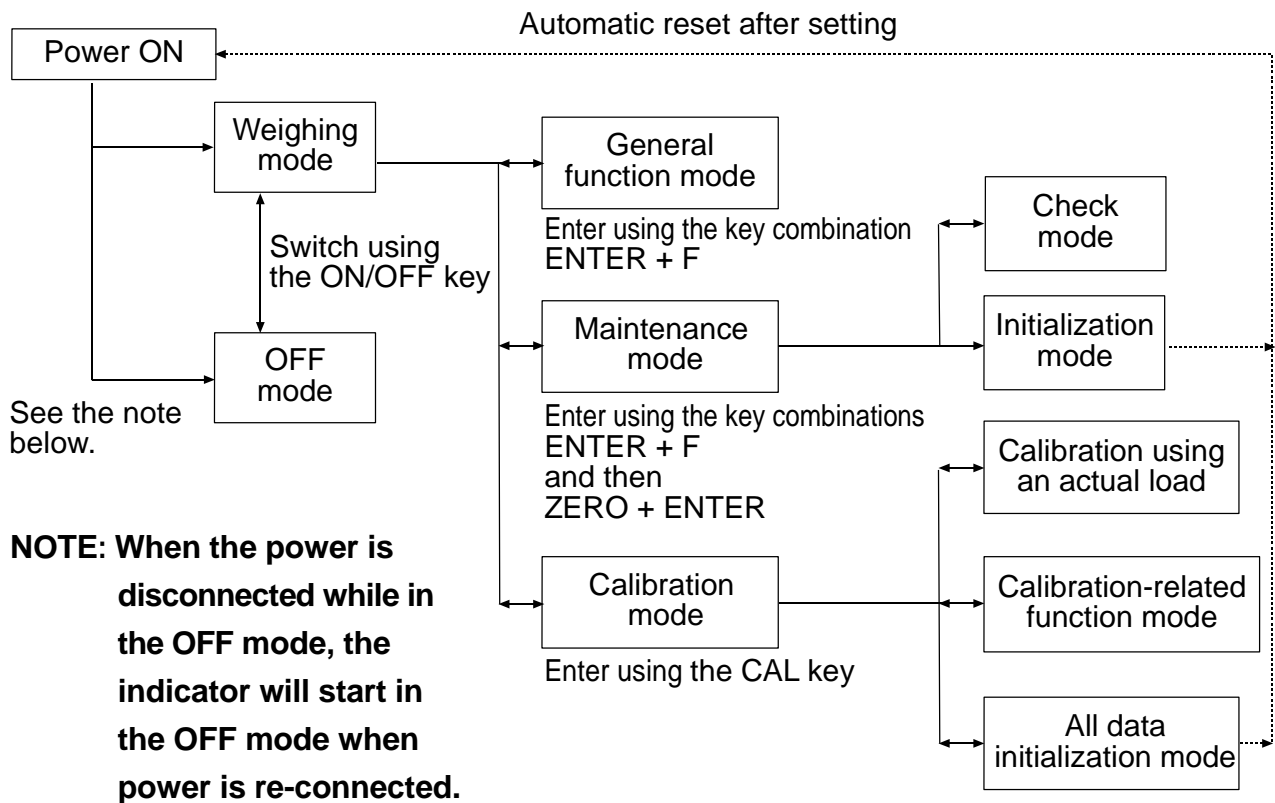

Fig.6 Mode map



7. Calibration

7.1. General Description

In the calibration mode, the operation to relate the output voltage from a load cell to the weight value and other operations directly related to weighing are performed.

Calibration with an actual load	<p>Calibration is performed using a calibration weight.</p> <ul style="list-style-type: none">• Zero calibration: Adjusts the indicator so that the measured value will be zero when no load is applied to the load cell.• Span calibration: Enter the calibration weight value and place the calibration weight on the load cell. <p>When the indicator enters the mode of calibration with an actual load, the tare weight and the zero value will be automatically cleared.</p>
Calibration-related function	<p>Setting basic constant values of the indicator such as the minimum division and weighing capacity and other data directly related to weighing is performed.</p> <p>Setting the parameters for digital span calibration is also performed.</p>
Digital span	<p>Calibration is performed without an actual load, by keying in the load cell output voltage (mV/V).</p> <ul style="list-style-type: none">• Input voltage at zero: Key in the load cell output at zero.• Input voltage at span: Key in the load cell output at span. (Load cell output at full capacity – load cell output at zero)• Calibration weight value at span: Key in the calibration weight value corresponding to the input voltage at span. (The input voltage at span is related to the weight value.)
All data initialization	<p>Clears all the data such as zero value, tare weight, calibration data and function data.</p>

NOTE: All the data set in the calibration mode is stored in the FRAM.

7.2. Calibration With an Actual Load (CAL SET)

Calibration is performed using a calibration weight

Before performing calibration for the first time, set the unit, decimal point position, minimum division and weighing capacity in the calibration-related function mode.

NOTE: To avoid drift caused by changes in temperature, warm up the indicator for ten minutes or more before performing calibration with an actual load.

Step 1 Press the ON/OFF key to turn the indicator ON (weighing mode) if it is in the OFF mode.

Remove the CAL key cover and press the CAL key.

CAL is displayed to indicate that the indicator enters the calibration mode.

Step 2 Press the ENTER key to display CAL SET. The indicator enters the mode of calibration with an actual load. To return to the weighing mode, press the ESC key.

Zero calibration

Step 3 Press the ENTER key to display CAL 0.

If zero calibration is not to be performed, press the F key and go to step 5.

To monitor the current weight value, press the CAL key. Press the CAL key again to display CAL 0.

Step 4 With nothing placed on the load cell, wait for the stabilization indicator to turn ON and press the ENTER key. - - - - - is displayed for approximately two seconds.

If span calibration is not to be performed, press the ESC key twice to return to the weighing mode.

Span calibration

Step 5 Press the ENTER key when CAL SP_n is displayed.

The calibration weight value (the weighing capacity currently set) is displayed and the least digit of the value blinks.

← → ▲ ▼ keys: Press to correct the value to the value of the calibration weight used.

CAL key : Press to monitor the current value (the gross weight) and press again to display the calibration weight value.

ESC key : Press three times to return to the weighing mode without performing span calibration.

Step 6 Place a calibration weight on the load cell. Wait for the stabilization indicator to turn ON and press the ENTER key. - - - - - is displayed for approximately two seconds.

Step 7 `[CALEnd]` is displayed. To re-adjust the span, press the F key.

Step 8 Press the ESC key. `[CALSET]` is displayed and the calibration data is written into the FRAM.

Step 9 The current state is the same as that of step 2. To return to the weighing mode, press the ESC key again.

NOTE: The blinking decimal point indicates that the current value is not the weight value.

If `[ErrX]` is displayed, an error has occurred. Refer to “7.4. Calibration Errors” to take some measures.

7.3. Calibration-Related Functions (CALF)

Step 1 Press the ON/OFF key to turn the indicator ON (weighing mode) if it is in the OFF mode.

Remove the CAL key cover and press the CAL key.

CAL is displayed to indicate that the indicator enters the calibration mode.

Step 2 Press the ENTER key to display CALSET. The indicator enters the mode of calibration with an actual load. To return to the weighing mode, press the ESC key.

Step 3 Press the ▲ or ▼ key to select CALF and press the ENTER key.

Step 4 Press the ▲ or ▼ key to select a function number to be used and press the ENTER key. The current setting value is displayed.

Step 5 Change the value as necessary. Two methods to change are available, depending on the function number as below

Method	Description
Selecting a parameter	Only the available parameter is displayed and blinks. Press the ▲ or ▼ key to select a parameter.
Inputting the value	All the digits are displayed and a digit to be changed blinks. Press the ◀ or ▶ key to select a digit and press the ▲ or ▼ key to change the value.

After setting, press the ENTER key. The next function number is displayed.

When the value is not to be changed, press the ESC key to return to the function number display.

Step 6 Press the ESC key. CALSET is displayed and the data of the calibration-related functions is written into the FRAM.

Press the ESC key again to return to the weighing mode.

NOTE: The blinking decimal point indicates that the current value is not the weight value.

If a value exceeding the settable range is entered, Err dt is displayed and the input is canceled.

Function No. Parameter or Setting range	Function	Description	Default value
<i>CALF01</i> 0 to 4	Unit	Unit of the weight value 0: None 1: g 2: kg 3: t 4: lb (USA version)	2
<i>CALF02</i> 0 to 5	Decimal point position	Decimal point position of the weight value 0: None 123456 1: 10 ¹ 12345.6 2: 10 ² 1234.56 3: 10 ³ 123.456 4: 10 ⁴ 12.3456 5: 10 ⁵ 1.23456	0
<i>CALF03</i> 1 to 6	Minimum division	Minimum division (d) of the weight value 1: 1 2: 2 3: 5 4: 10 5: 20 6: 50	1
<i>CALF04</i> 1 to 999999	Weighing capacity	Weighing capacity of the weighing instrument Weighing is possible up to the value of this setting plus 8 d. If the value exceeds this, overflow will occur and will not be displayed. The decimal point position is the same as the setting of <i>CALF02</i> .	20000
<i>CALF05</i> 0 to 100	Zero adjustment range	Range to enable zero adjustment by the ZERO key Expressed in percent of the weighing capacity with the calibration zero point as the center, when performing power-ON zero, with the initial zero point as the center. For example, if this is set to 2, the value in the range of $\pm 2\%$ of the weighing capacity with the calibration zero point at the center will set to zero.	2

Function No. Parameter or Setting range	Function	Description	Default value
<i>CALF06</i> 00 to 50	Zero tracking time	Performs zero tracking using this setting in combination with the setting of the zero tracking band. When 0.0, zero tracking will not be performed. Unit: second in 0.1 increments	00
<i>CALF07</i> 00 to 99	Zero tracking band	Performs zero tracking using this setting in combination with the setting of the zero tracking time. When 0.0, zero tracking will not be performed. Unit: d (minimum division) in 0.1 increments	00

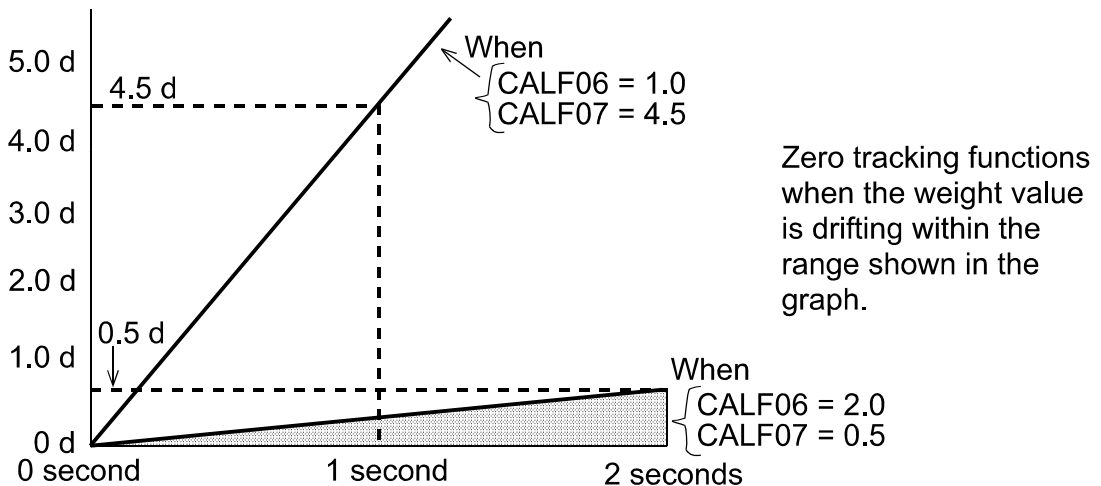
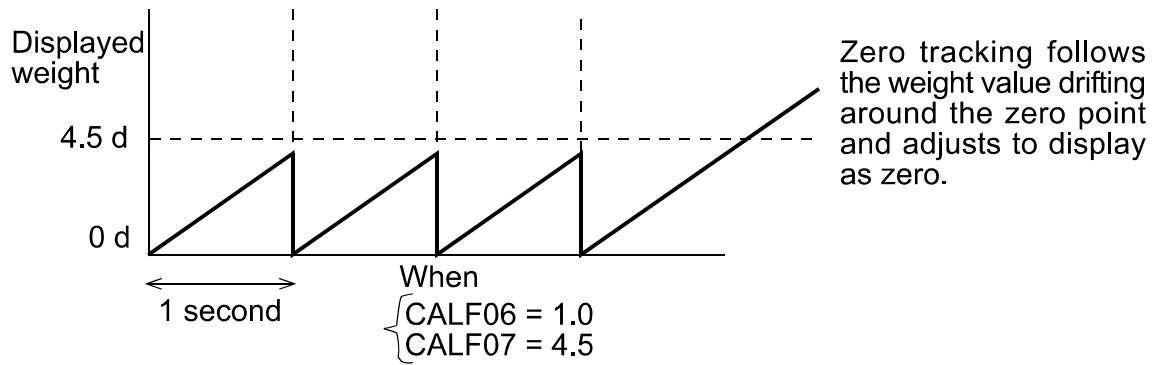

Function No. Parameter or Setting range	Function	Description	Default value
<i>CALF08</i> 00 to 99	Stability detection time	Performs stability detection using this setting in combination with the setting of the stability detection band. When 0.0, stability detection will not be performed. (Stable all the time) Unit: second in 0.1 increments	10
<i>CALF09</i> 0 to 9	Stability detection band	Performs stability detection using this setting in combination with the setting of the stability detection time. When 0, stability detection will not be performed. (Stable all the time) Unit: d (minimum division)	2
<p>Stability detection outputs the STABLE signal when changes in the weight value are within a certain range during a certain time.</p> <p>The graph illustrates the stability detection process. The top curve represents the 'Weight value' over time. It shows an initial rise, followed by a period of oscillation around a mean value. A horizontal dashed line represents the 'Stability detection band' (CALF09), which is centered on the mean weight value. A horizontal double-headed arrow indicates the 'Stability detection time' (CALF08), which is the duration for which the weight value remains within the band. The 'STABLE signal' is shown as a step function that is high (logic 1) when the weight value is within the band for the specified duration, and low (logic 0) otherwise. The graph shows two such periods where the STABLE signal is high.</p>			
<i>CALF10</i> 0 to 1	Tare and zero adjustment when unstable	Tare and zero adjustment when the weight value is unstable. 0: Disables both functions. 1: Enables both functions.	1
<i>CALF11</i> 0 to 1	Tare when the gross weight is negative	Tare when the gross weight is negative. 0: Disables tare. 1: Enables tare.	1
<i>CALF12</i> 0 to 1	Output when overflow and unstable	Standard serial output when the weight value overflows and is unstable. 0: Disables output. 1: Enables output.	1

Function No. Parameter or Setting range	Function	Description	Default value
<i>CALF 13</i> <i>1 to 3</i>	Over at negative gross weight	Condition to judge over when the gross weight is negative. A/D negative over or <i>1</i> : Gross weight < -999999 <i>2</i> : Gross weight < negative weighing capacity <i>3</i> : Gross weight < -19 d	<i>1</i>
<i>CALF 14</i> <i>1 to 2</i>	Over at negative net weight	Condition to judge over when the net weight is negative. Gross weight negative over or <i>1</i> : Net weight < -999999 <i>2</i> : Net weight < negative weighing capacity	<i>1</i>
<i>CALF 15</i> <i>0 to 1</i>	Clear the zero value	Select whether or not to clear the zero value. <i>0</i> : Disables. <i>1</i> : Enables.	<i>1</i>
<i>CALF 16</i> <i>0 to 1</i>	Zero upon power-ON	Select whether or not to perform zero upon power-ON. <i>0</i> : Disables. <i>1</i> : Enables.	<i>0</i>
<i>CALF 17</i> <i>-700000 to</i> <i>700000</i>	Input voltage at zero	Input voltage from a load cell at zero. Unit: mV/V In zero calibration during the calibration with an actual load, this value is determined.	<i>000000</i>
<i>CALF 18</i> <i>000000 1 to</i> <i>999999</i>	Input voltage at span	Input voltage from a load cell at span Unit: mV/V In span calibration during the calibration with an actual load, this value and the value of <i>CALF 19</i> are determined.	<i>200000</i>
<i>CALF 19</i> <i>1 to 999999</i>	Calibration weight value corresponding to Input voltage at span	The calibration weight value corresponding to the Input voltage at span of <i>CALF 18</i> . When performing digital span, <i>CALF 17</i> , <i>18</i> and <i>19</i> are required. The decimal point position is the same as the setting of <i>CALF02</i> .	<i>20000</i>

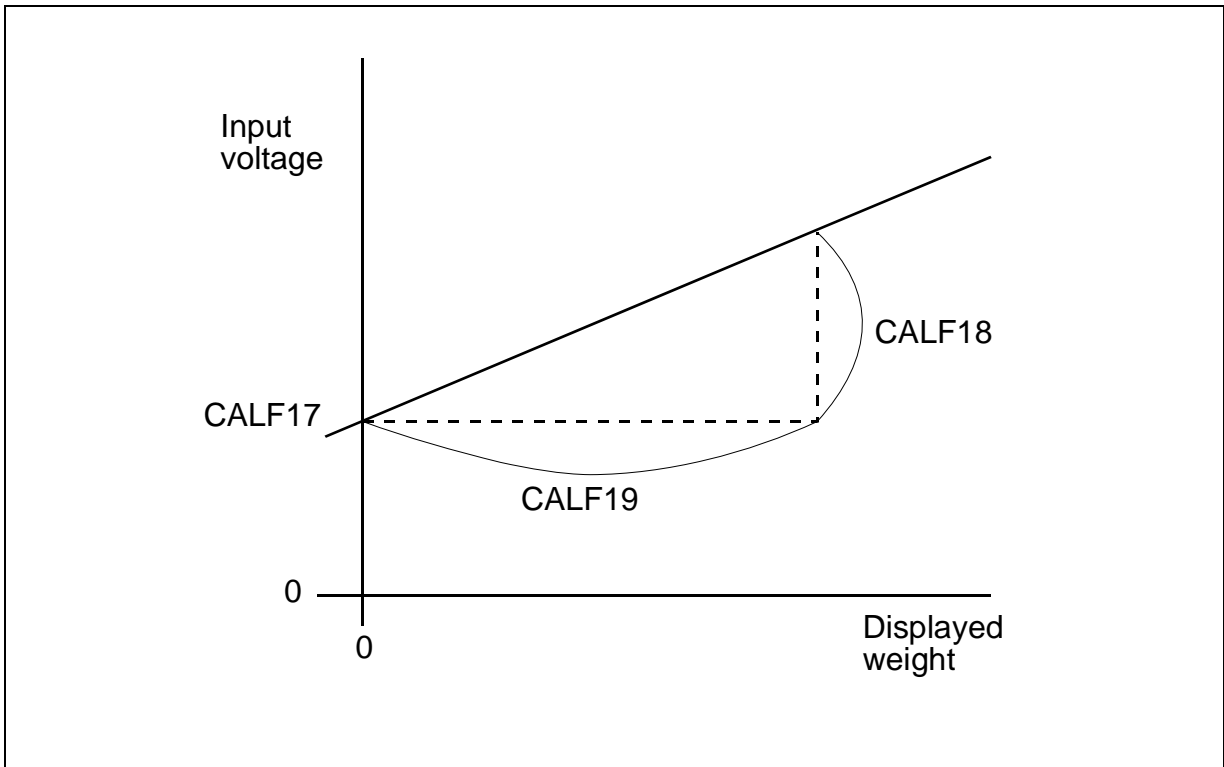

NOTE: Record the setting values of *CALF 17*, *18* and *19* in the “Setting List” at the end of the manual to prepare against a failure.

By changing the parameters of *CALF 17*, *18* and *19*, “zero calibration” and “span calibration” can be adjusted optionally. (Digital span accuracy approx. 1/5000: The accuracy varies depending on the load cell output accuracy and the conditions of calibration.)

Except for an emergency, perform calibration with an actual load.

<i>CALF20</i> 0 to 1	Output when the gross weight is negative	Output by the manual print command when the gross weight is negative. 0: Enables output. 1: Disables output.	0
<i>CALF21</i> 0 to 1	Communication restriction	Restriction on network-related communication such as changing station numbers or ID numbers and outputting by auto printing 0: Disables restriction. 1: Enables restriction.	0
<i>CALF22</i> 1 to 2	Header 2	Second header for serial output 1: GS / NT / TR 2: G_ / N_ / T_ (_ space)	1

7.4. Calibration Errors

When an error occurs during calibration, the error number is displayed.

If calibration is finished without releasing the error, the setting values will be restored to the state before calibration.

Calibration errors and remedies

Error No.	Description	Remedy
[Err 1	The display resolution (weighing capacity / minimum division) exceeds the specified value.	Make the minimum division greater or make the weighing capacity smaller. The specified value depends on the instrument or specifications.
[Err 2	Voltage at zero calibration exceeds in the positive direction.	Check the load cell rating and connection. When nothing is wrong with the rating and connection, adjust the load cell output as described in the next section.
[Err 3	Voltage at zero calibration exceeds in the negative direction.	When the load cell or A/D converter may be the cause of error, confirm it by using the check mode.
[Err 4	The value of the calibration weight exceeds the weighing capacity.	Use an appropriate calibration weight and calibrate again.
[Err 5	The value of the calibration weight is less than the minimum division.	
[Err 6	The load cell sensitivity is not sufficient.	Use a load cell with higher sensitivity or make the minimum division greater.
[Err 8	The load cell output voltage is too high when the load of the weighing capacity is placed.	Use a load cell with a greater rating or make the weighing capacity smaller.
[Err 7	Voltage at span calibration is less than voltage at the zero point.	Check the load cell connection.

7.5. Load Cell Output Adjustment

Add a resistor as shown below to adjust the load cell output.

Use a resistor with a high resistance value and a low temperature coefficient.

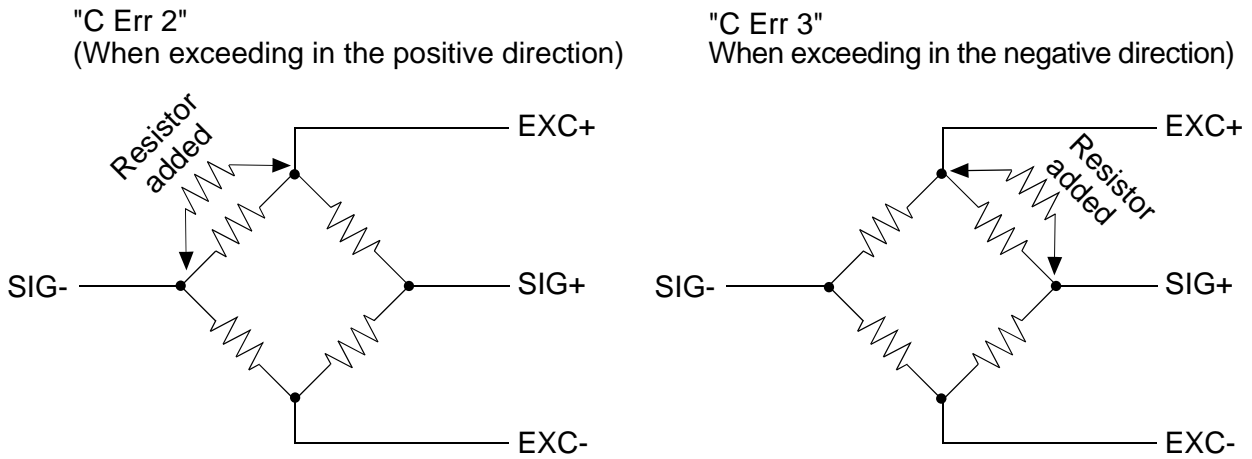

Fig.7 Load cell output adjustment

NOTE: As the zero adjustment range of the AD-4408A is wide, output adjustment is rarely required for the normal load cell.

Before adjusting the load cell output, check the load cell (deformation, clearance around the load cell, incorrect wiring and load cell type) and load cell connection.



8. General Functions

General functions are divided into groups per function and are indicated by the group name with the function number.

NOTE: General functions determine the AD-4408A performance and all of the settings are stored in the FRAM.

8.1. Setting Procedure

Step 1 While holding down the ENTER key, press the F key.

\boxed{FnC} is displayed to indicate that the indicator will enter the general function mode.

Step 2 Press the ENTER key. The indicator enters the general function mode.

To return to the weighing mode without entering the general function mode, press the ESC key.

Step 3 Press the $\boxed{\wedge}$ or $\boxed{\vee}$ key to select the function group to be set.

Display	Group name
$FnCF$	Basic function
$[L F$	Standard serial output
$***F$ $***F$ $***F$	Interfaces Refer to the instruction manual for each interface, available on our website.

Press the ENTER key. The function number will be displayed.

Step 4 Press the $\boxed{\wedge}$ or $\boxed{\vee}$ key to select the function number to be set.

Press the ENTER key. The current setting value will be displayed.

Step 5 Change the setting value using either one of the methods below.

Method	Description
Selecting a parameter	Only the available parameter is displayed and blinks. Press the $\boxed{\wedge}$ or $\boxed{\vee}$ key to select a parameter.
Inputting the value	All the digits are displayed and a digit to be changed blinks. Press the $\boxed{\leftarrow}$ or $\boxed{\rightarrow}$ key to select a digit and press the $\boxed{\wedge}$ or $\boxed{\vee}$ key to change the value.

After setting, press the ENTER key. The next function number is displayed.

When the parameter is not to be changed, press the ESC key to return to the function number display.

Step 6 Press the ESC key. The function number disappears and the indicator returns to the state of step 3.

Press the ESC key to store the setting values in the FRAM and return to the weighing mode.

NOTE: The blinking decimal point indicates that the current value is not the weight value.

If a value exceeding the settable range is entered, $\boxed{\text{Err dt}}$ is displayed and the input is canceled.

8.2. Adjusting the Digital Filter

Adjust the digital filter using F_{ncF05} (Digital filter) and F_{ncF06} (Frequency divider ratio).





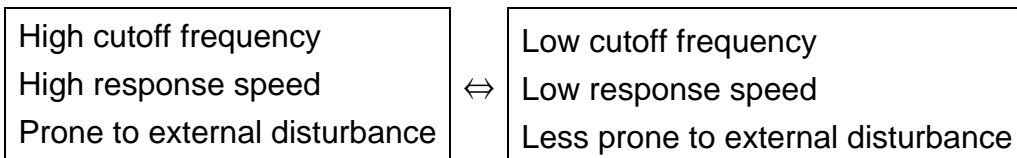

Method 1 While F_{ncF06} is fixed to 1 (divider ratio 1), adjust F_{ncF05} .
Cutoff frequency: 11.0 Hz to 0.7 Hz

Method 2 If Method 1 does not work, perform as follows:
While F_{ncF05} is fixed to 8 (1.0 Hz), adjust F_{ncF06} .
Cutoff frequency: 0.5 Hz to 0.1 Hz

$$\text{Digital filter cutoff frequency} = \frac{F_{ncF05} \text{ cutoff frequency}}{F_{ncF06} \text{ divider ratio}}$$



8.3. Basic Functions ($F_{nc}F$)

Function No. Parameter or Setting range	Function	Description	Default value
$F_{nc}F01$ 000000 to 111111	Disable key switch	Each digit of the setting corresponds to a key switch. Only available in the weighing mode. 0: Does not disable the key switch function. 1: Disables the key switch function. Key assignment to each binary digit <div style="display: flex; justify-content: space-around; align-items: center;"> <div style="text-align: center;">6th </div> <div style="text-align: center;">5th </div> <div style="text-align: center;">4th </div> <div style="text-align: center;">3rd </div> <div style="text-align: center;">2nd </div> <div style="text-align: center;">1st </div> </div>	000000 (binary)
$F_{nc}F02$ 0 to 6	F key	Assigns a function to the F key. 0: None 1: Manual print command 2: Hold 3: Alternate switch 4: Momentary switch 5: Clear the tare weight 6: Clear the zero value NOTE: Clearing the zero value can be enabled or disabled by $[ALF 15]$	0
$F_{nc}F03$ 1 to 3	Display update rate	1: 20 times/second 2: 10 times/second 3: 5 times/second	1
$F_{nc}F04$ 0 to 3	□ display	Assigns a function to the □ display. 0: None 1: Zero tracking in progress 2: Alarm (Zero range setting error, over) 3: F key status	0
$F_{nc}F05$ 0 to 9	Digital filter	Selects a cutoff frequency. 0: None 1: 11.0 Hz 2: 8.0 Hz 3: 5.6 Hz 4: 4.0 Hz 5: 2.8 Hz 6: 2.0 Hz 7: 1.4 Hz 8: 1.0 Hz 9: 0.7 Hz	8
$F_{nc}F06$ 1 to 10	Frequency divider ratio	Divides digital filter cutoff frequency by the setting.	1
$F_{nc}F07$ 1 to 2	Hold	1: Normal hold 2: Peak hold	1

8.4. Standard Serial Output ([L F])

Function No. Parameter or Setting range	Function	Description	Default value
[L F01] 1 to 5	Output data	1: Displayed weight 2: Gross weight 3: Net weight 4: Tare weight 5: Gross/Net/Tare	1
[L F02] 1 to 3	Data transfer mode	1: Stream 2: Auto printing ^(Note 1) 3: Manual printing	1
[L F03] 1 to 2	Baud rate	1: 600 bps 2: 2400 bps	2
[L F04] 0 to 99	ID number	Adds an ID number to the standard serial output. ^(Note 2) 0: Does not add an ID number. 1: 99:	0

NOTE: When “1: Enables restriction” is selected for [ALF2] (Communication restriction):

(Note 1) Auto printing will not be performed even if auto printing conditions are met.

(Note 2) ID numbers can not be changed.



9. Interface

9.1. Standard Serial Output

The standard serial output with 0 to 20 mA can be connected to a device such as an A&D printer or remote display. The interface has no power source. Therefore, the external devices to be connected must have a power source. The setting values of the standard serial output are changed in the general functions *CL F01* to *CL F04*.

Type	0 to 20 mA current loop
Data bits	7 bits
Start bit	1 bit
Parity	1 bit, even
Stop bit	1 bit
Baud rate	600, 2400 bps
Code	ASCII

9.1.1. Connection

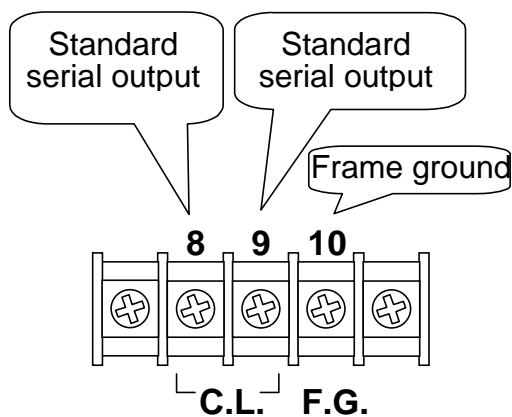

Fig.8 Standard serial output pin connection

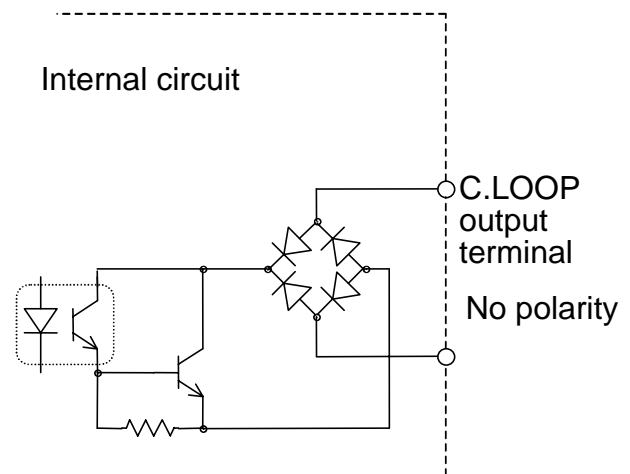

Fig.9 Standard serial output internal circuit

**NOTE: The standard serial output connection has no polarity.
When a shielded cable is used, connect the shield to the F.G. terminal.**

9.1.2. Output data

The data format used is A&D standard format. This is a format to be used with an A&D printer or remote display and consists of two headers, data, unit and a terminator.

A&D standard format

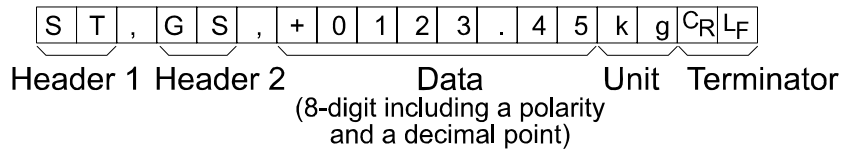

	ASCII code	Hexadecimal	Description
Header 1	ST	[53 54]	Stable
	US	[55 53]	Unstable
	OL	[4F 4C]	Overload
Header 2	GS	[47 53]	Gross weight
	NT	[4E 54]	Net weight
	TR	[54 52]	Tare weight
Separator	,	[2C]	
Data (ASCII code)	0 to 9	[30 to 39]	
	+	[2B]	
	-	[2D]	
	SP (space)	[20]	
	.	[2E]	
Unit (five types)	SP SP	[20 20]	No unit
	SP g	[20 67]	g
	kg	[6B 67]	kg
	SP t	[20 74]	t
	lb	[6C 62]	lb (USA version)
Terminator	CR	[0D]	
	LF	[0A]	

A&D standard format examples

	Header 1	Header 2	Data (8-digit including a polarity and a decimal point)	Unit	Terminator
Gross weight	S	T	,	G	S
Net weight	S	T	,	N	T
Tare weight	S	T	,	T	R
Data with a decimal point	S	T	,	G	S
Positive overflow	O	L	,	G	S
Negative overflow	O	L	,	G	S
Unstable data	U	S	,	G	S
"Output OFF" data	O	L	,	G	S

	Header 1	Header 2	Data (8-digit including a polarity and a decimal point)	Unit	Terminator
Gross weight	S	T	,	G	S
Net weight	S	T	,	N	T
Tare weight	S	T	,	T	R
Data with a decimal point	S	T	,	G	S
Positive overflow	O	L	,	G	S
Negative overflow	O	L	,	G	S
Unstable data	U	S	,	G	S
"Output OFF" data	O	L	,	G	S

	Header 1	Header 2	Data (8-digit including a polarity and a decimal point)	Unit	Terminator
Gross weight	S	T	,	G	S
Net weight	S	T	,	N	T
Tare weight	S	T	,	T	R
Data with a decimal point	S	T	,	G	S
Positive overflow	O	L	,	G	S
Negative overflow	O	L	,	G	S
Unstable data	U	S	,	G	S
"Output OFF" data	O	L	,	G	S

	Header 1	Header 2	Data (8-digit including a polarity and a decimal point)	Unit	Terminator
Gross weight	S	T	,	G	S
Net weight	S	T	,	N	T
Tare weight	S	T	,	T	R
Data with a decimal point	S	T	,	G	S
Positive overflow	O	L	,	G	S
Negative overflow	O	L	,	G	S
Unstable data	U	S	,	G	S
"Output OFF" data	O	L	,	G	S

	Header 1	Header 2	Data (8-digit including a polarity and a decimal point)	Unit	Terminator
Gross weight	S	T	,	G	S
Net weight	S	T	,	N	T
Tare weight	S	T	,	T	R
Data with a decimal point	S	T	,	G	S
Positive overflow	O	L	,	G	S
Negative overflow	O	L	,	G	S
Unstable data	U	S	,	G	S
"Output OFF" data	O	L	,	G	S

NOTE: The decimal point position is the same even when overflow occurs.

9.1.3. Data transfer mode

Three data transfer modes are available; stream, auto printing and manual printing.

Stream mode	Transmits data in sync with the display update rate. If the indicator can not catch up with the update rate because of the baud rate, the transmission is paused until the next updating. The transmitted data is the same as what is being displayed. Data that is not displayed is never transmitted.
Auto printing mode	Transmits data once only when the weight value with 5 d or greater is stable. For another transmission, the weight value must fall below 5 d once.
Manual printing mode	Transmits data when the F key, assigned as the manual print command, is pressed.

Functions related to the data transfer mode

- `[L F04]`: Adds an ID number to the standard serial output.

The example below is when an ID number is added.

@	0	9	S	T	,	G	S	,	+	0	1	2	3	.	4	5	k	g	C _R	L _F
---	---	---	---	---	---	---	---	---	---	---	---	---	---	---	---	---	---	---	----------------	----------------

ID number

- `[ALF20]`: Enables or disables the print command when the gross weight is negative.
- `[ALF22]`: Changes header 2 to G, N or T.



10. Maintenance

10.1. Error Messages

If an error message is displayed, refer to the chart below to take proper measures.

Error message	Cause	Remedy
$[S Err$	Program checksum error	Repair is required.
$Ad Err$	Data can not be acquired from the A/D converter.	Repair is required.
$rA Err$	Data can not be written into the backup memory.	Repair is required.
$FrAErr$	Correct data can not be read from the FRAM.	Perform initialization. If initialization does not clear the error, repair is required.
$[ALErr$	Calibration data is not correct.	Perform calibration.
$[ErrX$	Calibration error	Refer to "7.4. Calibration Errors".
$Err dt$	The setting value is out of the settable range.	Check the setting value and set again.

10.2. Check Mode

The check mode checks the performance of the display, key switches and external I/O.

10.2.1. Entering the check mode

Step 1 While holding down the ENTER key, press the F key.

$[FnC]$ is displayed to indicate that the indicator will enter the general function mode.

To return to the weighing mode, press the ESC key.

Step 2 While holding down the ZERO key, press the ENTER key.

$[hC]$ is displayed to indicate that the indicator will enter the check mode.

Press the ENTER key again to display an item to be checked.

Step 3 Press the \blacktriangle or \blacktriangledown key to select the item to be checked and press the ENTER key to enter the check mode of the selected item.

To exit from the current mode, press the ESC key.

Display	Item to be checked
[hcPEY	Key switches
[hc LL	Standard serial output
[hc*** [hc*** [hc***	Interfaces Refer to the instruction manual for each interface, available on our website.
[hc rS	Testing terminal
[hc Ad	A/D (Load cell)
[hc in	Internal count
[hcPr9	Program version
[hc Sn	Serial number
[S Pr9	Program checksum
[S FrA	Memory (FRAM) checksum
[ALFdt	Calibration-related functions

10.2.2. Checking the key switches

With [hcPEY displayed, press the ENTER key to enter the key switch check mode. In the key switch check mode, six squares (□) are displayed. Each square corresponds to a key switch as shown below.

When a key switch is pressed, the corresponding square moves up (□).

When the CAL key is pressed, the minus LED turns ON.

To exit from the key switch check mode, press the ESC key twice.

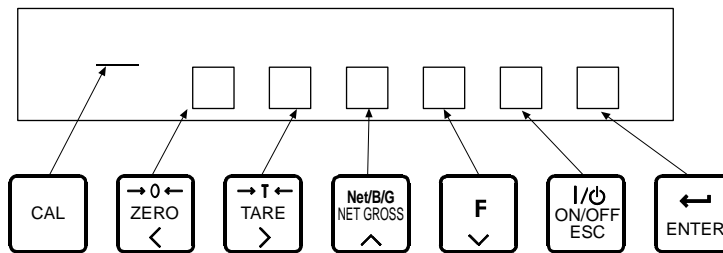

10.2.3. Checking the standard serial output

With [hc LL displayed, each time the ENTER key is pressed, the test data is transmitted with the baud rate set in the general functions and the decimal point blinks.

Test data [S T , G S , + 0 0 0 0 0 . 0 k g CR LF

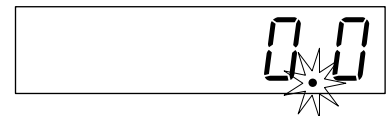

10.2.4. Checking interfaces

Refer to the instruction manual for each interface, available on our website.

10.2.5. Checking the testing terminal

The `[hc r5]` display is for checking the testing terminal. Do not use it.

10.2.6. Checking the A/D (load cell)

With `[hc Ad]` displayed, press the ENTER key to enter the A/D check mode. The load cell output value is displayed in mV/V.

The example below is when the internal count is 1.23456 mV/V.

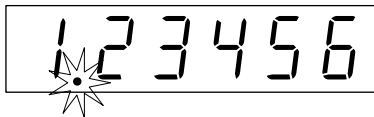

A digital display showing the value 1.23456. A starburst icon is positioned over the decimal point.

If the internal count exceeds $\pm 7\text{mV/V}$, the load cell may be damaged or the load cell may be connected incorrectly. Refer to “10.4. Checking the Load Cell Connection Using the Digital Multimeter” to check the connection.

10.2.7. Checking the internal count

With `[hc in]` displayed, press the ENTER key to enter the internal count check mode. The internal count value (display value times 10) is displayed.

The example below is when the internal count is 123.

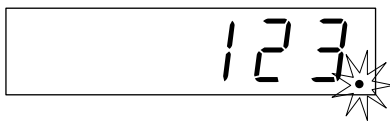

A digital display showing the value 123. A starburst icon is positioned over the last digit, 3.

10.2.8. Checking the program version

With `[hc Pr9]` displayed, press the ENTER key to display the version of the current program. The example below is when the program version is 1.00.



A digital display showing the letter P followed by the value 1.00.

10.2.9. Checking the serial number

With `[hc Sn]` displayed, press the ENTER key to display the last five digits of the serial number. The example below is when the last five digits of the serial number are 12345.

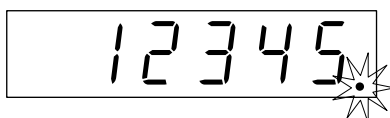

A digital display showing the value 12345. A starburst icon is positioned over the last digit, 5.

10.2.10. Checking the program checksum

With `[5 Pr9]` displayed, press the ENTER key to display the program checksum. The example below is when the checksum is EF.



A digital display showing the letter 5 followed by the value EF.

10.2.11. Checking the FRAM checksum

With [5 FrA] displayed, press the ENTER key to display the FRAM checksum. The memory set in the general functions is not counted.

The example below is when the checksum is EF.

[5 EF]

10.2.12. Checking the calibration-related functions

With [ALFdt] displayed, press the ENTER key to display the settings of the calibration-related functions.

NOTE: For contents and operations of the calibration-related functions, refer to “7.3. Calibration-Related Functions”.

The settings can not be changed here.

10.3. Initialization Mode

Initialization restores the contents of the FRAM to the default values.

Three types of initialization are available as shown below.

Initialization mode	Display	Description
RAM initialization	$in \ rA$	Initializes the contents of the RAM only. The zero and tare values will be restored to 0.
General functions initialization	$in \ Fnc$	Initializes the contents of the general functions stored in the FRAM.
All data initialization	$in \ ALL$	Initializes all the contents in the FRAM. The calibration-related data is also initialized. So, calibration is required before using the indicator again.

10.3.1. RAM initialization / General functions initialization

Step 1 While holding down the ENTER key, press the F key.

Fnc is displayed to indicate that the indicator will enter the general function mode.

To return to the weighing mode, press the ESC key.

Step 2 While holding down the ZERO key, press the ENTER key.

hc is displayed to indicate that the indicator will enter the check mode.

Step 3 Press the \uparrow or \downarrow key to select the initialization mode ($in \ rA$) and press the ENTER key.

Step 4 Press the \uparrow or \downarrow key to select the item to be initialized and press the ENTER key.

Step 5 All the status LEDs blink to prompt a confirmation. To initialize, press and hold the ENTER key for three seconds or more.

After initialization, the indicator is reset and all the display segments are ON. And the indicator enters the weighing mode.

To exit from this mode without performing initialization, press the ESC key.

10.3.2. All data initialization

- Step 1 Remove the CAL key cover and press the CAL key.
CAL is displayed to indicate that the indicator enters the calibration mode.
- Step 2 Press the ENTER key to display CALSET. The indicator enters the mode of calibration with an actual load. To return to the weighing mode, press the ESC key.
- Step 3 Press the \uparrow or \downarrow key to select the all data initialization mode (in iALL) and press the ENTER key.
- Step 4 All the status LEDs blink to prompt a confirmation. To initialize, press and hold the ENTER key for three seconds or more.
After initialization, the indicator is reset and all the display segments are ON.
And the indicator enters the weighing mode.
To exit from this mode without performing initialization, press the ESC key.

10.4. Checking the Load Cell Connection Using the Digital Multimeter

Using the digital multimeter, load cell connection can be checked easily.

The figure below indicates the measurement points to check the connection.

When a summing box is used, the same measurements are required inside the box.

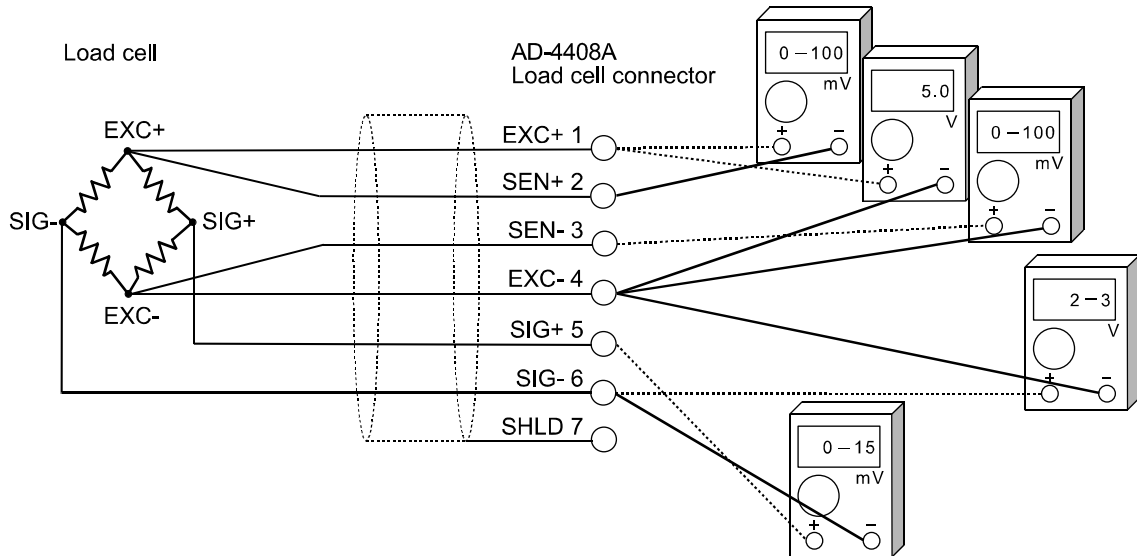

Fig.10 Checking the load cell connection

Checking the load cell connection

Measurement point		What to measure	How to judge
EXC+ 1	SEN+ 2	Voltage drop at EXC+ of the load cell cable	Normally less than 100mV. Can exceed 1V when the load cell cable is extremely long. Should be 0V for 4-wire connection.
EXC+ 1	EXC- 4	Load cell excitation voltage	Correct value: 4.75 to 5.25V
SEN- 3	EXC- 4	Voltage drop at EXC- of the load cell cable	Normally less than 100mV. Can exceed 1V when the load cell cable is extremely long. Should be 0V for 4-wire connection.
SIG- 6	EXC- 4	Load cell median voltage	About 2.5V (half of the excitation voltage)
SIG+ 5	SIG- 6	Load cell output voltage	Compared with the theoretical value obtained from the load cell rating, actual load and excitation voltage. Normally 0 to 15mV.

If the AD-4408A does not function properly, contact the nearest A&D dealer.

Use the chart below to write necessary items before contacting the dealer.

Item	Record your value	Description
Load cell connection	<input type="checkbox"/> 4-wire connection <input type="checkbox"/> 6-wire connection	For 4-wire connection, a jumper is required between EXC+ and SEN+, and between EXC- and SIG-.
Load cell type		
Load cell rating	[Unit]	
Load cell rated output	[mV/V]	
Load cell maximum safe overload	[%]	
Number of load cells used	[pcs]	
Summing box (status of use)		
Length of extension cable	[m]	Cable length between the indicator and the device such as a summing box
Indicator initial load	[Unit]	
Indicator minimum division	[Unit]	In case of decimal number, all the digits Example: 0.002 kg
Indicator weighing capacity	[Unit]	In case of decimal number, all the digits Example: 10.000 kg
Load cell output value at the initial load (at no load)	[mV/V]	-0.1mV/V to load cell rated sensitivity (depending on the initial load)
Load cell output value when loaded to capacity (or when a mass of choice is loaded)	Load cell output value [mV/V] at the load [Unit]	When loaded to capacity, the output value at the initial load + load cell rated output (within the maximum safe overload)

Measurement point	What to measure	Result
EXC+ 1 SEN+ 2	Voltage drop at EXC+ of the load cell cable	[mV]
EXC+ 1 EXC- 4	Load cell excitation voltage	[V]
SEN- 3 EXC- 4	Voltage drop at EXC- of the load cell cable	[mV]
SIG- 6 EXC- 4	Load cell median voltage	[V]
SIG+ 5 SIG- 6	Load cell output voltage	[mV]



11. Setting List

When performing maintenance, use the following list as a memo.
In case of inquiry about the product, inform of the user setting.

11.1. Basic Functions

Function No. Parameter or Setting range	Description	Default value	User setting
<i>FncF01</i> 000000 to 111111	Disable key switch 0: Does not disable the key switch function. 1: Disables the key switch function.	000000 (binary)	
<i>FncF02</i> 0 to 6	Assigns a function to the F key. 0: None 1: Manual print command 2: Hold 3: Alternate switch 4: Momentary switch 5: Clear the tare weight 6: Clear the zero value	0	
<i>FncF03</i> 1 to 3	Display update rate 1: 20 times/second 2: 10 times/second 3: 5 times/second	1	
<i>FncF04</i> 0 to 3	Assigns a function to the □ display. 0: None 1: Zero tracking in progress 2: Alarm (Zero range setting error, over) 3: F key status	0	
<i>FncF05</i> 0 to 9	Digital filter (cutoff frequency) 0: None 1: 11.0 Hz 2: 8.0 Hz 3: 5.6 Hz 4: 4.0 Hz 5: 2.8 Hz 6: 2.0 Hz 7: 1.4 Hz 8: 1.0 Hz 9: 0.7 Hz	8	
<i>FncF06</i> 1 to 10	Frequency divider ratio	1	
<i>FncF07</i> 1 to 2	Hold 1: Normal hold 2: Peak hold	1	

11.2. Standard Serial Output

Function No. Parameter or Setting range	Description	Default value	User setting
<i>[L F01</i> <i>1 to 5</i>	Output data 1: Displayed weight 2: Gross weight 3: Net weight 4: Tare weight 5: Gross/Net/Tare	<i>1</i>	
<i>[L F02</i> <i>1 to 3</i>	Data transfer mode 1: Stream 2: Auto printing 3: Manual printing	<i>1</i>	
<i>[L F03</i> <i>1 to 2</i>	Baud rate 1: 600 bps 2: 2400 bps	<i>2</i>	
<i>[L F04</i> <i>0 to 99</i>	ID number 0: Does not add an ID number. 1: 99:	<i>0</i>	

11.3. Calibration-Related Functions

Function No. Parameter or Setting range	Description	Default value	User setting
<i>CALF01</i> 0 to 4	Unit of the weight value 0: None 1: g 2: kg 3: t 4: lb (USA version)	2	
<i>CALF02</i> 0 to 5	Decimal point position of the weight value: 10 ⁿ	0	
<i>CALF03</i> 1 to 6	Minimum division (d) of the weight value 1: 1 2: 2 3: 5 4: 10 5: 20 6: 50	1	
<i>CALF04</i> 1 to 999999	Weighing capacity of the weighing instrument The decimal point position is the same as the setting of <i>CALF02</i> .	20000	
<i>CALF05</i> 0 to 100	Range to enable zero adjustment by the ZERO key Expressed in percent of the weighing capacity with the calibration zero point as the center	2	
<i>CALF06</i> 0.0 to 5.0	Zero tracking time (Unit: second) When 0.0, zero tracking will not be performed.	0.0	
<i>CALF07</i> 0.0 to 9.9	Zero tracking band (Unit: 0.1 d) When 0.0, zero tracking will not be performed.	0.0	
<i>CALF08</i> 0.0 to 9.9	Stability detection time (Unit: second) When 0.0, stability detection will not be performed.	1.0	
<i>CALF09</i> 0 to 9	Stability detection band (Unit: d) When 0, stability detection will not be performed.	2	
<i>CALF10</i> 0 to 1	Tare and zero adjustment when the weight value is unstable. 0: Disables both functions. 1: Enables both functions.	1	
<i>CALF11</i> 0 to 1	Tare when the gross weight is negative. 0: Disables tare. 1: Enables tare.	1	
<i>CALF12</i> 0 to 1	Standard serial output if the weight value overflows and is unstable. 0: Disables output. 1: Enables output.	1	

Function No. Parameter or Setting range	Description	Default value	User setting
<i>CALF 13</i> 1 to 3	Condition to judge over when the gross weight is negative. A/D negative over or 1: Gross weight < -999999 2: Gross weight < negative weighing capacity 3: Gross weight < -19 d	1	
<i>CALF 14</i> 1 to 2	Condition to judge over when the net weight is negative. A/D negative over or 1: Net weight < -999999 2: Net weight < negative weighing capacity	1	
<i>CALF 15</i> 0 to 1	Select whether or not to clear the zero value. 0: Disables. 1: Enables.	1	
<i>CALF 16</i> 0 to 1	Select whether or not to perform zero upon power-ON. 0: Disables. 1: Enables.	0	
<i>CALF 17</i> - 700000 to 700000	Input voltage from a load cell at zero. X.XXXXX mV/V	000000	
<i>CALF 18</i> 0.0000 1 to 999999	Input voltage from a load cell at span X.XXXXX mV/V	2.00000	
<i>CALF 19</i> 1 to 999999	The value of the calibration weight corresponding to the span input voltage	20000	
<i>CALF 20</i> 0 to 1	Select whether or not to output when the gross weight is negative. 0: Enables output. 1: Disables output.	0	
<i>CALF 21</i> 0 to 1	Select whether or not to restrict network-related communication. 0: Disables restriction. 1: Enables restriction.	0	
<i>CALF 22</i> 1 to 2	Second header for serial output 1: GS / NT / TR 2: G_ / N_ / T_ (_ space)	1	



12. External Dimensions

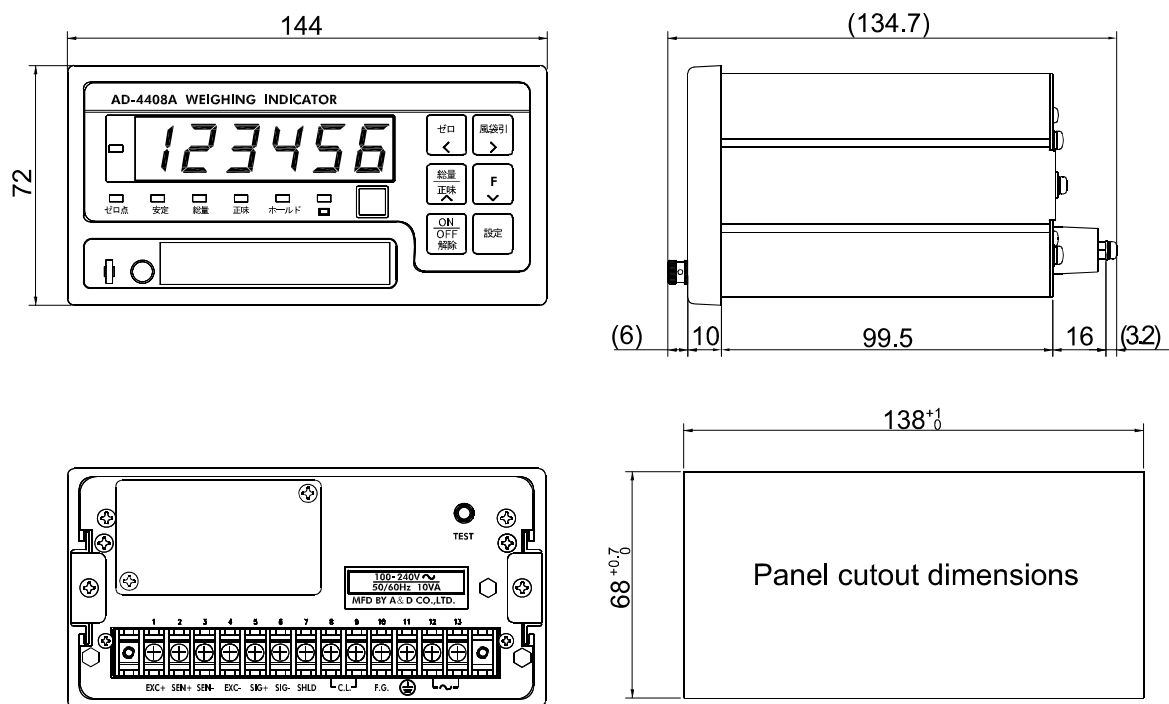

Unit: mm

Fig.11 External dimensions



A&D Company, Limited

3-23-14 Higashi-Ikebukuro, Toshima-ku, Tokyo 170-0013 JAPAN
Telephone: [81] (3) 5391-6132 Fax: [81] (3) 5391-6148

A&D ENGINEERING, INC.

1756 Automation Parkway, San Jose, California 95131 U.S.A.
Telephone: [1] (408) 263-5333 Fax: [1] (408)263-0119

A&D INSTRUMENTS LIMITED <UK Office>

Unit 24/26 Blacklands Way, Abingdon Business Park, Abingdon, Oxfordshire
OX14 1DY United Kingdom
Telephone: [44] (1235) 550420 Fax: [44] (1235) 550485

A&D INSTRUMENTS LIMITED <German Sales Office>

Große Straße 13 b 22926 Ahrensburg Deutschland
Telefon: [49] (0) 4102 459230 Telefax: [49] (0) 4102 459231

A&D Australasia Pty Ltd.

32 Dew Street, Thebarton, South Australia 5031 AUSTRALIA
Telephone: [61] (8) 8301-8100 Fax: [61] (8) 8352-7409

A&D KOREA Limited

한국에이.엔.디(주)
대한민국 서울시 영등포구 여의도동 36-2 맨하탄 빌딩 8층
(8th Floor, Manhattan Bldg. 36-2 Yoido-dong, Youngdeungpo-ku, Seoul, KOREA)
전화: [82] (2) 780-4101 팩스: [82] (2) 782-4280

A&D RUS CO., LTD.

Компания Эй энд Ди Рус
121357, Российская Федерация, г.Москва, ул. Верейская, дом 17
(Bldg. 17, Vereyskaya st., Moscow, 121357 RUSSIAN FEDERATION)
тел.: [7] (495) 937-33-44 факс: [7] (495) 937-55-66

A&D Instruments India Private Limited

ऐ&डी इन्स्ट्रूमेन्ट्स इण्डिया प्रा० लिमिटेड
509, उद्योग विहार , फेस -5, गुडगांव - 122016, हरियाणा , भारत
(509, Udyog Vihar, Phase-V, Gurgaon - 122 016, Haryana, India)
फोन : 91-124-4715555 फैक्स : 91-124-4715599