



AD-4430B

DIN Rail Weighing Module

INSTRUCTION MANUAL

This manual and Marks

All safety messages are identified by the following, "WARNING" or "CAUTION", of ANSI Z535.4 (American National Standard Institute: Product Safety Signs and Labels). The meanings are as follows:

 WARNING	A potentially hazardous situation which, if not avoided, could result in death or serious injury.
 CAUTION	A potentially hazardous situation which, if not avoided, may result in minor or moderate injury.



This is a hazard alert mark.

- This manual is subject to change without notice, at any time, to improve the product.
- The contents of the product specifications and this manual are subject to change without any obligation on the part of the manufacturer.
- Under the copyright laws, the software (program) described in this manual is copyrighted, with all rights reserved.
The software may be installed into one computer and may not be installed into other computers without the prior written consent of A&D Company, Limited. Copying includes translation into another language, reproduction, conversion, photocopy and offer or loan to another person.

© 2014 **A&D Company, Limited** All rights reserved.

No part of this publication may be reproduced, transmitted, transcribed, or translated into any language in any form by any means without the written permission of A&D Company, Limited.

Contents

1.	Compliance	4
1.1.	Compliance with FCC rules	4
1.2.	Compliance with European Directives	4
1.3.	Precautions For Safety Use	4
2.	Outline and Features	5
3.	Specifications	6
3.1.	Analog to Digital Unit (Load cell Input, A/D Converter).....	6
3.2.	Display And Keys.....	6
3.3.	General.....	6
3.3.1.	Interface.....	6
3.3.2.	Weighing Function.....	7
3.3.3.	General.....	7
3.3.4.	Accessories.....	7
3.3.5.	Dimensions	8
3.4.	Names (The Front Panel And Rear Panel).....	9
4.	Installing The Module.....	10
4.1.	Conditions To Install The Module.....	10
4.2.	Power Supply	10
4.3.	Loadcell Cable	10
4.4.	Shield Cable	11
4.5.	Connecting Loadcell Cable	11
4.6.	Verifying Loadcell Cable	12
5.	Operations.....	13
5.1.	General Functions	13
5.1.1.	Zero Adjustment.....	13
5.1.2.	Zero Tracking	13
5.1.3.	The Tare Function.....	13
5.1.4.	Customizing The Function Of the Switch F	14
5.1.5.	Customizing The Function Of the Display x.....	15
5.1.6.	Memory Backup.....	15
5.1.7.	The Detection For The Zero Band.....	15
5.1.8.	Upper Or Lower Limit Detection Function.....	15
5.1.9.	The Hold Function	16
5.2.	Mode Map And Operation Switches.....	17
5.2.1.	Mode Map	17
5.2.2.	Operation Switches	18
5.3.	Calibration	19
5.3.1.	Outline	19
5.3.2.	The Calibration With An Actual Load (Using A Mass)	20
5.3.3.	Gravity Acceleration Correction	21
5.3.4.	Outline Of The Linearization Function	22
5.3.5.	The Actual Load Linearization Function	23

5.3.6.	The Function $L-Fnc$ Related To The Calibration	24
5.3.7.	The Function $L-Fnc$ Related To The Linearization Function	28
5.3.8.	Error Codes For The Calibration.....	29
5.3.9.	Adjustment Of The Loadcell Output	29
5.4.	General Functions	30
5.4.1.	The Procedure To Store New Parameters.....	30
5.4.2.	The Adjustment Of The Digital Filter.....	31
5.4.3.	The List Of The Basic Functions.....	32
5.4.4.	The List Of The Hold Function.....	33
5.4.5.	The List Of The BCD Function.....	34
6.	Interface.....	35
6.1.	The Parallel BCD Output.....	35
6.1.1.	Timing Chart Of The BCD Output	35
6.1.2.	Terminals Of The BCD Output.....	35
6.1.3.	The State Of The BCD Output.....	35
6.1.4.	Positive Logic And Negative Logic	36
7.	Maintenance	37
7.1.	Error Messages.....	37
7.2.	Verifying The Load Cell Connections (DIAGNOS).....	37
7.2.1.	Guideline To Verify The Load Cell Connections	37
7.2.2.	The Operation With The BCD Input	38
7.2.3.	The Operation With The Switch.....	38
7.2.4.	The Result Of Verifying The Connection.....	38
7.3.	Check Mode.....	39
7.3.1.	Entering The Check Mode	39
7.3.2.	Verifying The Switch Operation	39
7.3.3.	Checking The BCD Output.....	39
7.3.4.	Monitoring The A/D Converter (For Load cell Output).....	40
7.3.5.	Monitoring The Internal Value	40
7.3.6.	Monitoring The Program Version.....	40
7.3.7.	Monitoring The Serial Number.....	40
7.3.8.	Monitoring The Checksum Of The Program	40
7.3.9.	Monitoring The Checksum Of An Internal FRAM.....	40
7.3.10.	Displaying Function Parameters For Calibration.....	40
7.4.	Initializing Parameters	41
7.4.1.	Initializing Mode For RAM And Function Parameters.....	41
7.4.2.	Initializing The Whole Data.....	41
7.5.	Verifying The Load cell Connections Using Multimeter.....	42
7.5.1.	Check List Of The Load cell Connections.....	42
7.6.	The Parameter List For The Function List.....	44
7.6.1.	Basic Functions.....	44
7.6.2.	The List Of The Hold Function.....	45
7.6.3.	The List Of The BCD Function.....	46
7.6.4.	The List Of The Calibration	47
7.6.5.	The List Of The Linearization Function	49
8.	Dimensions	50

Illustrations

Illustration 1	Dimensions.....	8
Illustration 2	Front panel & rear panel.....	9
Illustration 3	Mounting the module.....	9
Illustration 4	Cable type.....	10
Illustration 5	Load cell connection.....	11
Illustration 6	Peak hold / Averaging hold.....	16
Illustration 7	Mode Map (State Transition Diagram).....	17
Illustration 8	Gravity Acceleration Graph.....	22
Illustration 9	Digital linearization.....	22
Illustration 10	Load cell output adjustment.....	29
Illustration 11	Wire Name of Load Cell.....	37
Illustration 12	Connection Check of Load Cell.....	42

1. Compliance

1.1. Compliance with FCC rules

- Please note that this equipment generates, uses and can radiate radio frequency energy. This equipment has been tested and has been found to comply with the limits of a Class A computing device pursuant to Subpart J of Part 15 of FCC rules. These rules are designed to provide reasonable protection against interference when this equipment is operated in a commercial environment. If this unit is operated in a residential area it may cause some interference and under these circumstances the user would be required to take, at his own expense, whatever measures are necessary to eliminate the interference.
(FCC = Federal Communications Commission in the U.S.A.)

1.2. Compliance with European Directives

- CE** This appliance complies with the statutory EMC (Electromagnetic Compatibility) directive 2004/108/EC and the Low Voltage Directive 2006/95/EC for safety of electrical equipment designed for certain voltages.

Note: The displayed value may be adversely affected under extreme electromagnetic influences.

1.3. Precautions For Safety Use

Before use, confirm the following articles for safe operation.

- **Grounding The Module**
Ground the module to the DIN rail with certainty. Separate this earth ground line from others, like ground line of a motor, inverter or a power source. Unless the indicator is grounded, it may result in receiving an electric shock, cause operation error or catch fire.
- **Proper Power Source And Power Cable**
Confirm the AC voltage, frequency and power tolerance of the power cable. If the voltage range of the cable is lower than the power line voltage, it may cause leakage or catching fire. Use pole compression terminals to connect the power cable to the terminals.
- **Fuse**
The fuse is installed to help prevent the module from catching fire. The module is equipped with many safety circuits. Therefore, the fuse is not damaged in normal operation. If the fuse is damaged, do not replace it, contact your local A&D dealer. This trouble may have been caused by strong electric discharge.
- **Splashing Water**
The module is not water-resistant type.
- **Flammable Gas**
Do not install the module where flammable gas is present.
- **Heat Radiation Of The Module**
Space out instruments to radiate heat sufficiently. Use a cooling fan to keep the operating temperature of the module within specifications.

2. Outline and Features

The AD-4430B has the following features.

- The weighing module is a weighing indicator that amplifies signals from a load cell, converts it to digital data and displays it as a mass value.
- This indicator has the following performance :
 - Input sensitivity : 0.15 $\mu\text{V} / \text{d}$ (d = minimum division)
 - Display resolution : 99,999 d in maximum
 - Sampling rate : 1000 times/second
 - Input voltage range : -35 mV to +35 mV (-7 mV/V to +7 mV/V)
- The calibration using gravity acceleration correction :

The function compensates for weighing error due to the difference of gravity acceleration between the calibration place and the measurement place.
- The digital linearization function :

The digital linearization function can rectify and reduce the linearity deviation using weighing points during the zero and capacity setting. Up to four weighing points can be specified. The high-order correction curve is used between each points.
- Digital span mode :

Keying in the load cell output voltage (mV/V) allows calibration to be performed without an actual load.

3. Specifications

3.1. Analog to Digital Unit (Load cell Input, A/D Converter)

Input sensitivity	0.15 $\mu\text{V}/\text{d}$ or greater (d = minimum division)	
Input voltage range	-35 mV to +35 mV (-7 to +7 mV/V)	
Zero adjustment range	-35 mV to +35 mV (-7 to +7 mV/V)	
Load cell excitation voltage (Load cell drive capacity)	5 VDC $\pm 5\%$, 60 mA with remote sensing capability (Maximum 4 x 350 Ω load cells)	
Temperature coefficient	Zero	$\pm 0.02 \mu\text{V}/^\circ\text{C}$ Typ. $\pm 0.1 \mu\text{V}/^\circ\text{C}$ max
	Span	$\pm 3 \text{ ppm}/^\circ\text{C}$ Typ. $\pm 15 \text{ ppm}/^\circ\text{C}$ max
Non-Linearity	0.005% of full scale	
A/D conversion method	Delta-sigma method	
A/D resolution count	Approximately 16,000,000 counts	
Display resolution	99,999 d max. (d = minimum division)	
Sampling rate	1000 times/second	

3.2. Display And Keys

Display element	Measurement display	5 - digit 7-segment green LED
	Status indicators	6 red LEDs
Measurement display	Numerical display	Switches between NET and GROSS
	Decimal point	Selectable decimal places (10^1 , 10^2 , 10^3 , 10^4)
	Overflow display	All the digits turn OFF. (When the polarity is negative, the minus sign appears at the highest-order digit.)
Status indicators	G: GROSS, N: NET, H: HOLD, S: STABLE, Z: ZERO, X: Preset function selected from the function list.	
Key switches	F/ESC, \rightarrow (ZERO), \uparrow (TARE), ENT	

3.3. General

3.3.1. Interface

BCD Output	MDR connector 36pins female type
------------	----------------------------------

BCD Output And I/O Output

Output circuit	Open collector transistor
Isolation	Photo coupler
Output current	50 mA max.
Saturation voltage	0.5V max. @50 mA

I/O Input

Input circuit	DC contact input
Open voltage	Approx. 5 V
OFF current	0.1 mA max.
ON current	2 mA min.
Threshold voltage	2V
Chattering suppression time	10 msec.

3.3.2. Weighing Function

Zero adjustment	Sets the gross weight to zero by pressing the → (ZERO) key. Selection of disable or enable for the operation when unstable. The zero value is backup by FRAM. Zero adjustable range : Can be set optionally in the range of 1 to 100% of the weighing capacity.
Zero tracking	Tracks the weight drift around the zero point to maintain zero. Zero tracking time : 0.0 to 5.0 seconds Can be set optionally within the range Zero tracking band : 0.0 to 9.9 d Can be set optionally within the range
Tare	Sets the net weight to zero by pressing the ↑ (TARE) key. The tare weight is backup by FRAM. Tare range : Gross weight ≤ Weighing capacity
Stability detection	Turns ON the stabilization indicator S when the variables of the weight values per sampling are within the set band in the set time. Stability detection time : 0.0 to seconds Can be set optionally within the range Stability detection band : 0 to 9d Can be set optionally within the range
Digital filter	Cutoff frequency (-3 dB) range : 0.7 to 100 Hz
Zero detection	Detects to place nothing on the weighing pan.
Comparator	Compares the measurement with these limits and outputs the results.
Hold function	Displays the measurement value held. Select from sample hold, peak hold, average hold.

3.3.3. General

Data backup	Zero value, tare weight, calibration, function parameters backup by FRAM. (Approx. 10 years)
Power failure countermeasure	FRAM. (Approx. 10 years)
Power source	DC 24 V, +10%, -15%
Power consumption	Approximately 6 W
Operating temperature	-10 °C to +50 °C,
Operating humidity	85 %RH or less (no condensation)
Installation method	DIN rail mount
Mass	Approximately 180 g

3.3.4. Accessories

Item	Quantity	Model name
Power source connector	1	FMC1.5/2-ST-3.5

3.3.5. Dimensions

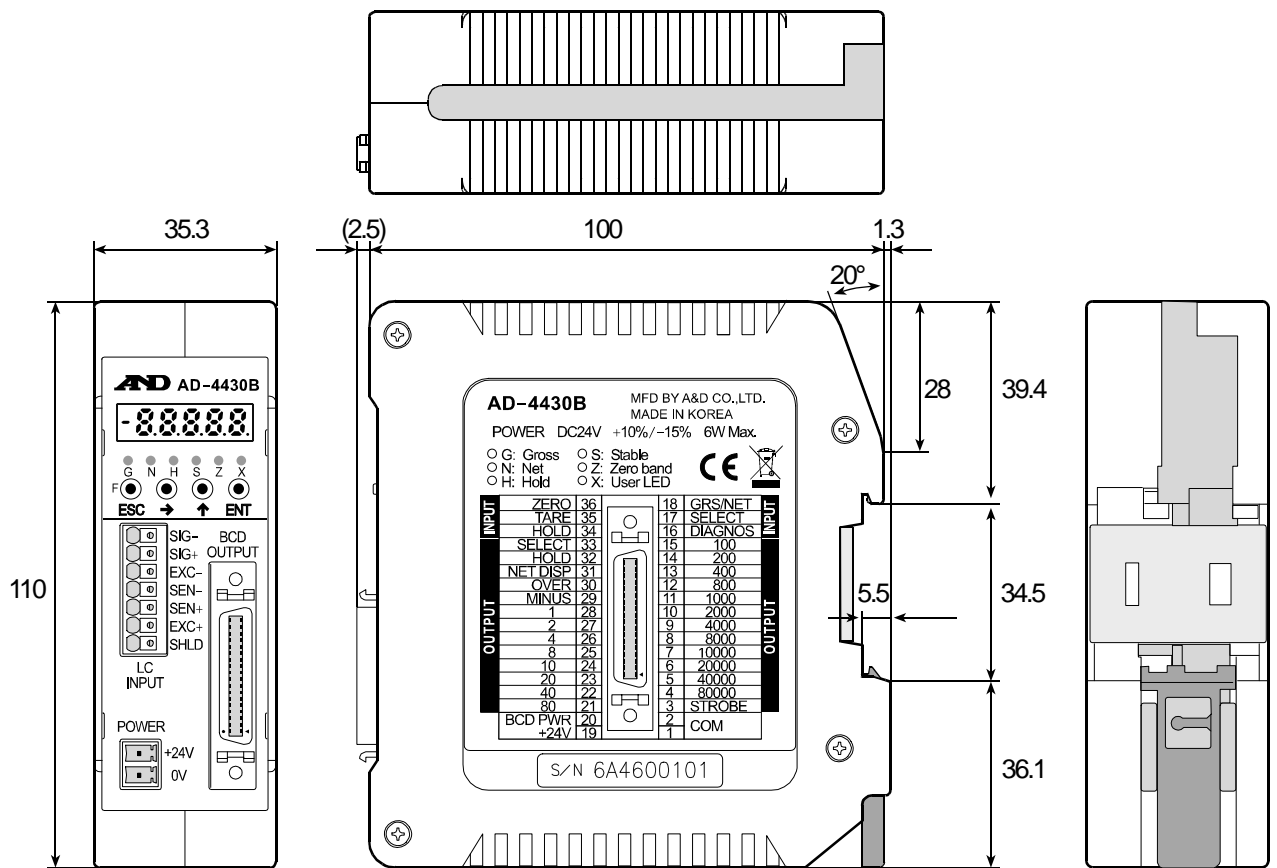

Unit : mm

Illustration 1 Dimensions

3.4. Names (The Front Panel And Rear Panel)

Illustration 2 Front panel & rear panel

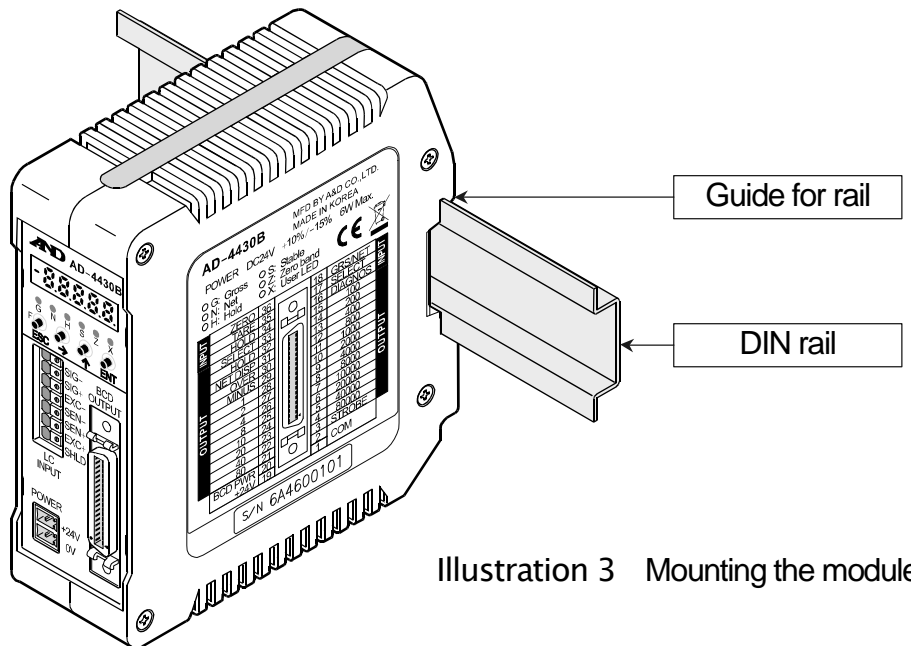
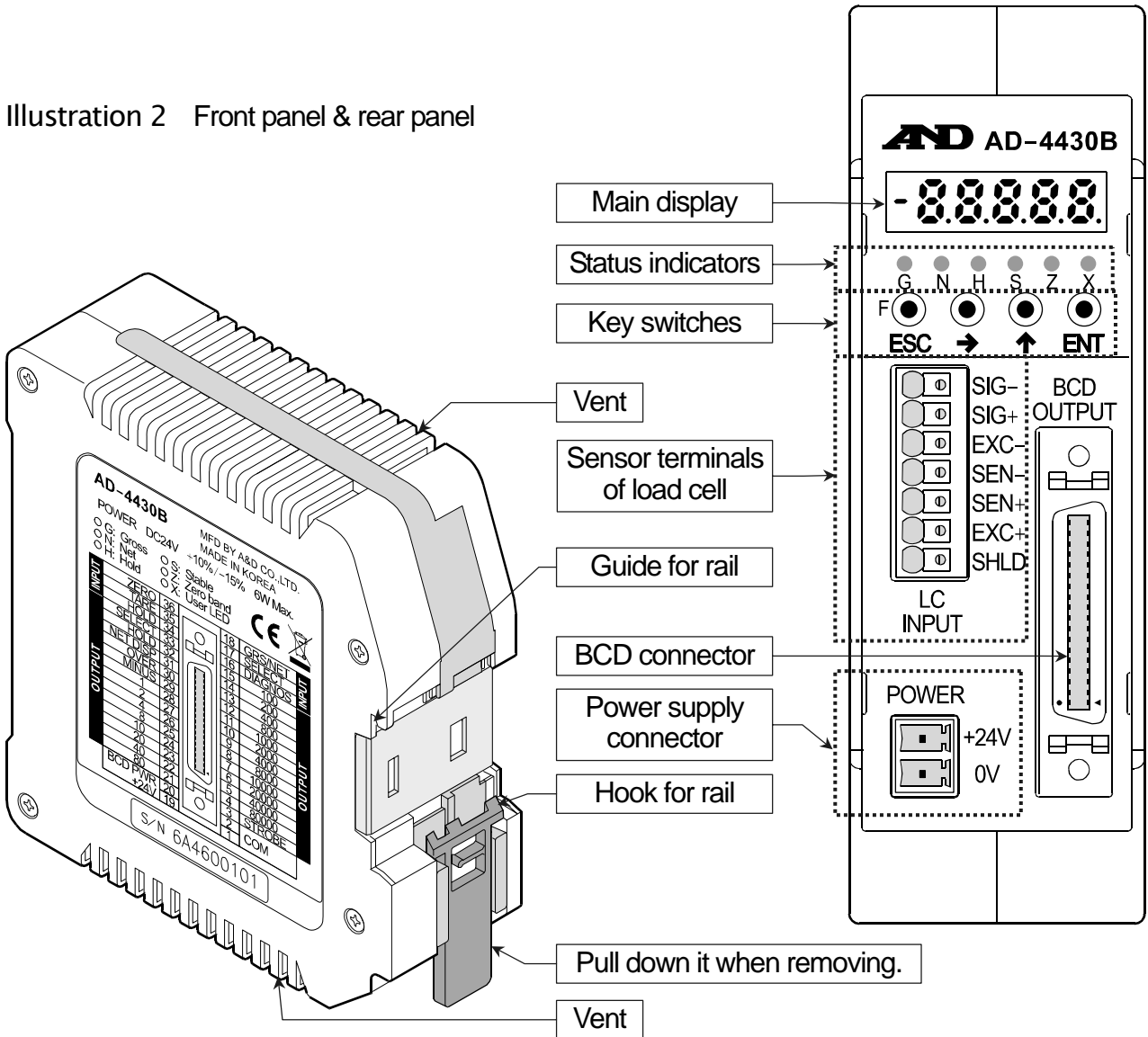

Illustration 3 Mounting the module

4. Installing The Module

This section is explained for the environment to install the module and for the terminals of the power source and load cell cable. Refer to each section of options for I/O interface.

4.1. Conditions To Install The Module

- The module is a precision electronic instrument. Handle it carefully.
- The operating temperature is -10°C to $+50^{\circ}\text{C}$.
- Do not install the module in direct sunlight.

4.2. Power Supply

⚠ CAUTION

- Earth ground the module to prevent electrical shock or indicator malfunction.
- Before connecting the module to the power source, read the instruction manual thoroughly.
- Do not connect the module to the power source before the installation is complete.
- ⚠ □ To avoid electrical shock, do not handle the power cable with a wet hand.
- ⚠ □ Earth ground the module. Do not share the ground line with other electrical power equipment.
- The power requirement is 24 DCV, $+10\%$ to -15% .
Use a stable power source free from instantaneous power failure or noise.
- To avoid a malfunction, do not share the power line with other devices.
- The output voltage of a load cell is a very sensitive signal. Keep all electrical noise sources away from the load cell and load cell cable.
- Use shielded I/O cables. Connect the cable shield to the F.G. terminal or the module housing.

4.3. Loadcell Cable

Load cell cables should have high insulation and shielding performance.

Use shielded cables with the insulator that is made of materials with high insulation resistance such as Teflon and polyethylene. **NOTE: Teflon is a registered trademark of DuPont.** When using the extension cable, we recommend using A&D's load cell cables.

AX-KO162-5M to 100M (5m to 100m)

Cross-sectional area of the conducting wire 0.5mm^2 6 wire cable equipped

Cable diameter $\phi 9\text{mm}$

Ex. Rod crimping terminal



Illustration 4 Cable type

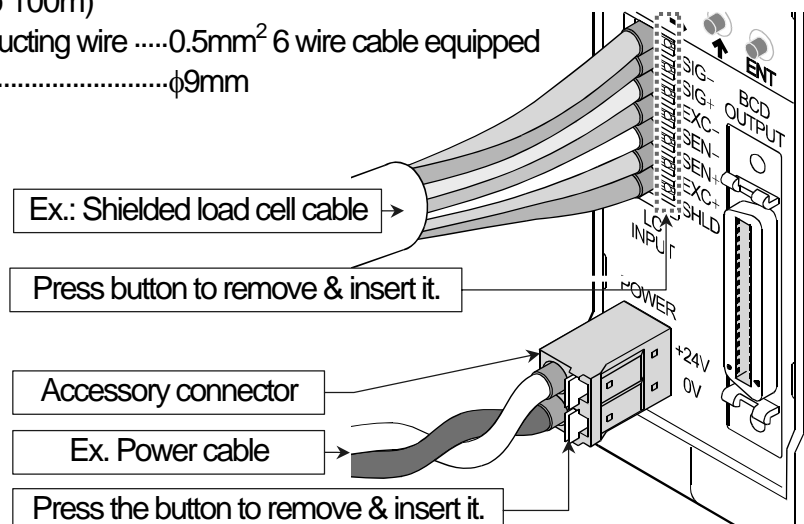

4.4. Shield Cable

Connect the load cell shield wire only to the shield terminal of the AD-4430B.

As a general rule, No ground is connected between the load cell and the AD-4430B. This is to prevent the ground loop generated by multiple ground points. A ground loop can be created along the wiring route, and interference such as high-frequency noise becomes more likely.

4.5. Connecting Loadcell Cable

Shield Cable Connection

As a general rule, only connect the load cell cable's shield wire to the module's shield terminal. This is because when there are multiple ground points, it becomes easier for noise to occur as a result of a ground loop. However, when there are higher priorities than noise prevention, such as explosion prevention systems or static electricity release routes, this rule does not necessarily need to be followed.

Load Cell Terminal Connections

Two types of load cell connection are available: 6-wire connection and 4-wire connection. For high precision and stable weighing, 6-wire connection is recommended.

Terminal No.		Terminal Name & Function
1	SIG-	Load cell input (-)
2	SIG+	Load cell input (+)
3	EXC-	Load cell excitation voltage (-)
4	SEN-	Sensing input (-)
5	SEN+	Sensing input (+)
6	EXC+	Load cell excitation voltage (+)
7	SHLD	Shield

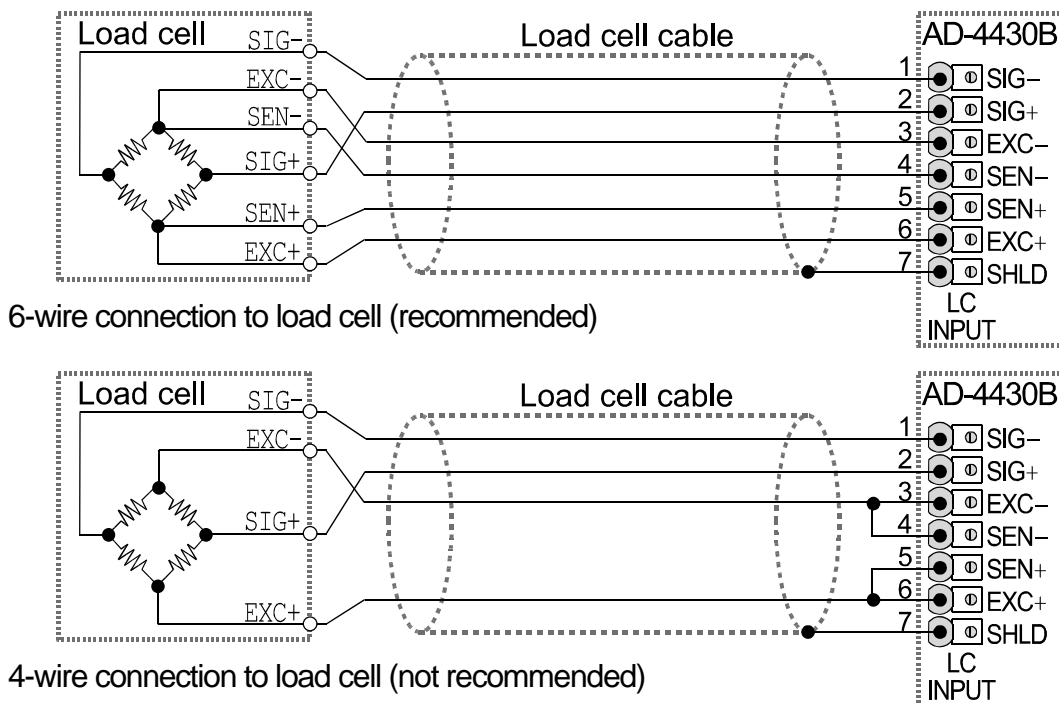

Illustration 5 Load cell connection

Type	Advantages	Disadvantages	Description
6-wire connection (recommended)	The error is small even when the load cell cable is extended, a thin load cell cable is used, or multiple load cells are used.	Complicated wiring	Use a 6-wire shielded cable when a summing box is used.
4-wire connection	Simple wiring	The influence of the load cell cable resistance worsens the temperature coefficient. Prone to the influence of the contact resistance of the connector	The error increases when the load cell cable is extended or multiple load cells are used.

- Precautions to be taken when using the 4-wire connection:
- If the 4-wire connection has to be used, please take the following measures.
 - Be sure to connect terminals EXC+(6) and SEN+(5) and terminals SEN-(4) and EXC-(3).
 - When lengthening the load cell cable, try to use cable with a large cross-sectional area. Also, keep the cable as short as possible.

4.6. Verifying Loadcell Cable

When the load cell connection is complete, perform a connection check using the following procedure.

- Perform a visual check to ensure that the wiring is correct.
- Turn the module on.
When calibration has not yet been carried out, the display value may be blank. However, as long as there are no problems with the display, confirmation can still be carried out using check mode.
- Enter the check mode and check the load cell output value.
Refer to "7.3.Check Mode" to enter the A/D check mode.
- Confirm that the displayed load cell output value matches the specified value. Normally the displayed value will be the load cell rated output value or less.
- If an error occurs, refer to "7.2. Verifying The Loadcell Connections (DIAGNOS)" or "7.5. Verifying The Loadcell Connections Using Multimeter".

5. Operations

5.1. General Functions

5.1.1. Zero Adjustment

- Zero adjustment is a function to set the gross weight to zero. It is performed by pressing the **→(ZERO)** key.
- The zero adjustment range is set in **CAL05** (Zero adjustment range) and is expressed in percent of the weighing capacity with the calibration zero point as the center.
- Zero adjustment is disabled, even within the zero adjustment range, when the A/D converter overflow occurs.
- A ZERO error is output if zero adjustment is not performed.
- The zero value is stored in the non-volatile memory and is maintained, even if the power is disconnected.
- Clearing the zero value is performed using the **F** key assigned to clear the zero value.
- **Functions Related To Zero Adjustment**
 - **CAL05**(Zero adjustment range) : A value between 0% and 100% can be specified.
 - **CAL10**(Tare and zero adjustment when unstable) : The selection to enable or disable tare and zero adjustment when unstable.
 - **CAL16**(Zero upon power-ON) : The selection whether or not to perform zero upon power-ON.

5.1.2. Zero Tracking

- The zero tracking is a function to track the gross weight drift around the zero point to maintain zero.
- The zero tracking time is set in **CAL06**(Zero tracking time) and the zero tracking band is set in **CAL07**(Zero tracking band). When the gross weight drift is within the specified ranges, zero tracking is performed automatically.
- A ZERO error is not output even if zero tracking is not performed.
- **Functions Related To Zero Tracking**
 - **CAL06**(Zero tracking time) : The value between 0.0 and 5.0 seconds can be specified.
 - **CAL07**(Zero tracking band) : The value between 0.0 and 9.9 d can be specified. (d = minimum division)

5.1.3. The Tare Function

- Tare is a function to store the gross weight as the tare value and set the net weight to zero. It is performed by pressing the **↑(TARE)** key.
- The tare weight is stored in the non-volatile memory and is maintained, even if the power is disconnected.
- Clearing the tare weight is performed using the **F** key assigned to clear the tare weight.
- **Functions Related To The Tare Function**
 - **CAL10**(Tare and zero adjustment when unstable) : The selection to enable or disable tare and zero adjustment when unstable.
 - **CAL11**(Tare when the gross weight is negative) : The selection to enable or disable tare when the gross weight is negative.

Clearing The Tare Weight And Zero Adjustment

The way to clear the tare weight and zero adjustment : While pressing and holding the

↑(TARE) key, turn on the module. Another way : In turning off the module, while pressing and holding the **↑(TARE)** key, press the **ENT** key.

5.1.4. Customizing The Function Of the Switch F

- Assign a function to the **F** key in the general functions.
- **Functions Related To The F Key**
 - Assigns a function to the **F** key from the functions of **Fnc02**(**F** key) below :
 - 0: None
 - 1: Manual print command
 - 2: Hold
 - 3: Alternate switch
 - 4: Momentary switch
 - 5: Display selection
 - 6: Clear the tare weight
 - 7: Clear the zero value
 - **CAL15**(Clear the zero value) : The selection to enable or disable clearing the zero value.
 - **CAL20**(Output when the gross weight is negative) : The selection to enable or disable the print command when the gross weight is negative.

Alternate switch and momentary switch

By assigning these switches to the **F** key, the ON/OFF status of the **F** key can be transmitted to the master station. This is useful when building a network or performing maintenance. The function of the display x can be specified by the **F** key and can be monitored. These switches work as follows :

Alternate switch

When pressing and releasing the switch once, the state of the switch is maintained. Press the switch again to turn off or on.

Momentary switch

Only while the switch is being pressed, the switch is ON. When it is released, it is OFF.

5.1.5. Customizing The Function Of the Display x

- Assign a function to the display x in the general functions.
- **Functions Related To The Display x**
 - Assigns a function to the o display from the functions of **Fnc04**(Display x) below :
 - 0: None
 - 1: Zero tracking in progress
 - 2: Alarm (Zero range error, over)
 - 3: **F** key status
 - 4: Zero band
 - 5: HI output (Over the upper limit value)
 - 6: OK output (Within upper and lower limit values)
 - 7: LO output (Below the lower limit value)
 - 8: User input 1

F key status

When alternate switch or momentary switch is selected at **Fnc02**, the **F** works.

The display turns ON when the **F** key is ON and turns OFF when the **F** key is OFF.

5.1.6. Memory Backup

- Zero value, tare weight, calibration data and function data are written into non-volatile memory(FRAM). The FRAM does not require batteries. The data retention period is 10 years. Therefore, this module does not equipped the backup battery.

5.1.7. The Detection For The Zero Band

- Zero band is a function to detect whether an object has been placed on the weighing pan. Zero band is defined as a state of the zero band when the weighing value is within the preset value for the zero band.
- **Functions Related To The Zero Band**
 - **Fnc08**(Set value of zero band) : The value of zero band can be specified.
 - **Fnc09**(Mass to be compared with zero band) : The selection of the gross weight or net weight to compare the value of zero band.

5.1.8. Upper Or Lower Limit Detection Function

- This is a function to detect whether the weighed value is above an upper limit value or below a lower limit value.
- **Functions Related To The Detection Function**
 - **Fnc10**(Upper limit value) or **Fnc11**(Lower limit value) : A comparative upper or lower limit value can be set.
 - **Fnc12**(Weight compared with upper and lower limits) : Gross weight or net weight to be compared with the upper or lower limit value can be selected.
 - **Fnc13**(Logic output for upper and lower limits) : Positive logic or negative logic to output the upper and lower limit can be selected.

5.1.9. The Hold Function

- There are three types of hold functions which can be used for different purposes.
- **Normal hold**
Holds the value displayed at the time the hold command was received.
- **Peak hold**
Holds the maximum value reached after the hold command was received.
The value will be refreshed if it increases again.
- **Averaging hold**
This function averages weighing data over a certain period of time and then holds the result.
It is useful for measuring things that are difficult to weigh such as an animal that won't settle down, or for averaging out the weight of an object in an unstable state. In addition, it can reduce the effects of breezes which the digital filter cannot eliminate.
- **Functions Related To The Hold Function**
 - **Fnc07(Hold)** : The type of hold function can be selected.
 - To set operating conditions for the hold function : Set the averaging time length, standby time, or start and stop conditions with **HLd01** to **07**. (Will not affect normal holds)

Peak hold

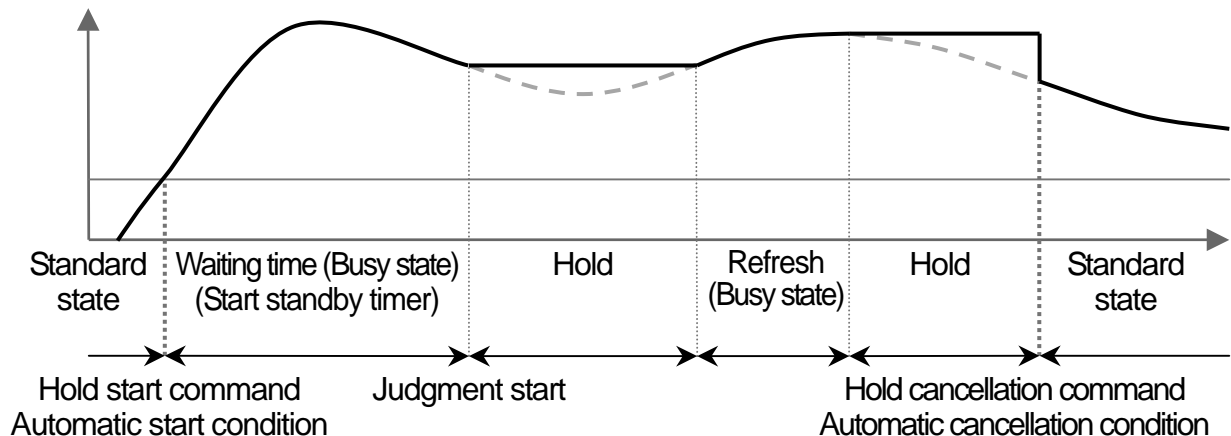

Averaging hold

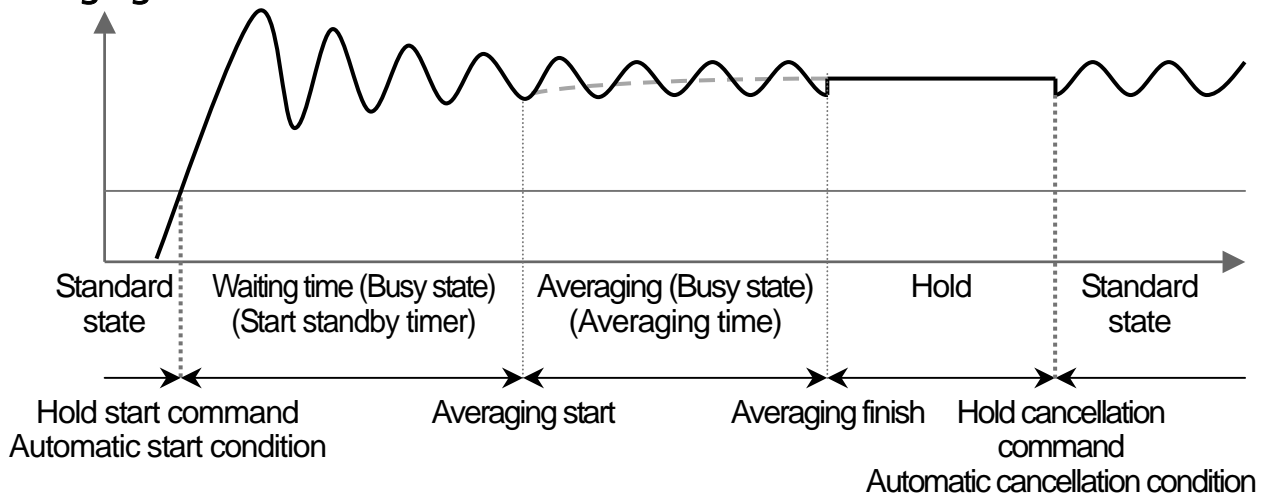

Illustration 6 Peak hold / Averaging hold

5.2. Mode Map And Operation Switches

5.2.1. Mode Map

- The module has several modes to perform various operations. Perform mode switching by the key operation shown below, only in the direction of the solid arrow. After setting a mode, the module resets automatically. Alternatively, the module resets when the power is disconnected.

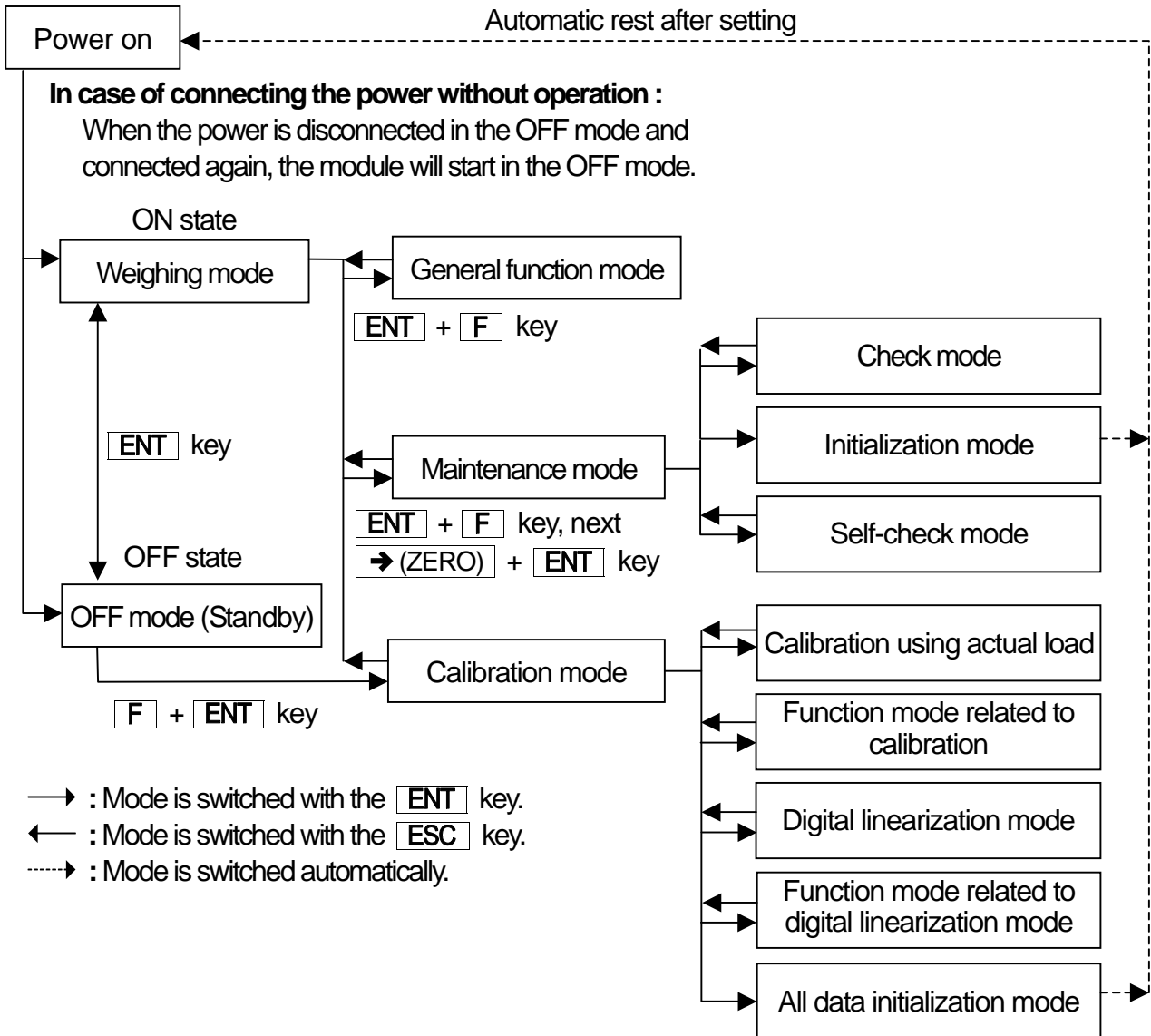

Illustration 7 Mode Map (State Transition Diagram)

5.2.2. Operation Switches

Key	State	Function and Use
F	Weighing mode	The display switch between gross and net in factory setting.
→	Weighing mode	The zero key to perform the zero adjustment.
	Setting mode	The key to change a selected item or move a flashed figure.
↑	Weighing mode	The tare key.
	Setting mode	The key to select parameter or increase number.
ENT	Weighing mode	When turning off the module, press and hold the key.
	OFF mode (Standby)	When turning on the module, press the key.
	Setting mode	The key to store new settings.
ESC	Weighing mode	Function key can be selected the function and use.
	Setting mode	The return key or escape key.
ENT + F	Weighing mode	The keys to proceed to the function mode.
→ + ENT	Function mode	The keys to proceed to the check mode.
F + ENT	OFF mode (Standby)	The keys to proceed to the calibration mode.

5.3. Calibration

5.3.1. Outline

- In the calibration mode, the operation to relate the output voltage from a load cell to the mass value and other operations directly related to weighing are performed.

Calibration with an actual load	<p>Calibration is performed using a calibration weight.</p> <ul style="list-style-type: none"> ■ Zero calibration :Press ENT key when no load is applied. ■ Span calibration :Enter the calibration weight value and place the calibration weight. <p>When the module enters the mode of calibration with an actual load, the tare weight and the zero value will be automatically cleared.</p>
Digital span	<p>Calibration is performed without an actual load, by numerical input of the load cell output voltage (mV/V). Set the functions related to the calibration.</p> <ul style="list-style-type: none"> ■ Input voltage at zero : Numerical input of the load cell output at zero. ■ Input voltage of span : Numerical input of the load cell output of span. (Load cell output at full capacity – load cell output at zero) ■ Calibration weight value of span : Numerical input of the calibration weight value corresponding to the input voltage of span. (These value relate the input voltage of span and the weight value.)
Dual range	<p>The dual range is the display feature that the weighing range is divided into two depending on the value of gross or net and the minimum division is changed.</p>
Gravity acceleration correction	<p>The correction calculates and corrects for gravity acceleration if the location where the module was calibrated and the location where it is being used in are different.</p>
Digital linearization	<p>Nonlinearity correction feature to correct weighing errors that occur halfway between the zero point and weighing capacity. Up to 4 points can be input in addition to the zero point, and the intervals between each point will be calculated using curves.</p>
Function related to calibration	<p>The function stores basic parameters of the module such as the minimum division and weighing capacity and other data directly related to weighing is performed. It includes the parameters for digital span calibration, dual range or gravity acceleration correction is also performed.</p>
All data initialization	<p>All the data such as zero value, tare weight, calibration data and function data are initialized.</p>

All the parameters in the calibration mode is stored in the FRAM.

5.3.2. The Calibration With An Actual Load (Using A Mass)

Calibration is performed using a calibration weight. Before performing calibration for the first time, set the unit, decimal point position, minimum division and weighing capacity in the calibration-related function mode (**C-Fnc**).

Note To avoid drift caused by changes in temperature, warm up the indicator for ten minutes or more before performing calibration with an actual load.

Step 1 In the OFF mode (Standby), Press the **[F]** + **[ENT]** key to enter to the calibration mode and display **[CAL]**.

[CAL]

Step 2 Press the **[ENT]** key to start the calibration and display **[C-SET]**. If returning to the weighing mode, press the **[ESC]** key.

[C-SET]

Zero Calibration

Step 3 Press the **[ENT]** key to display **[CAL 0]**.
If zero calibration is not to be performed, press the **[↑]** key and proceed to step 5. If you want to check the current weighing value, press the **[→]** key. When pressing the **[↑]** key again, **[CAL 0]** is display.

[CAL 0]

Step 4 Placed nothing on the pan and wait for the stabilization (**S** LED). Press the **[ENT]** key. **[-----]** is displayed for approximately two seconds. If span calibration is not performed, press twice the **[ESC]** key for returning to the weighing mode.

[-----]

Span Calibration

Step 5 Press the **[ENT]** key when **[C-SPn]** is displayed. The calibration weight value (the current weighing capacity) is displayed and the least digit of the value blinks. Correct the value using the **[→]** and **[↑]** key so as to be the value of the calibration weight used. If span calibration is not performed, press three times the **[ESC]** key for returning to the weighing mode.

[C-SPn]

02000

03000

Example

[-----]

Step 6 Place the calibration weight on the pan. Wait for the stabilization (**S** LED). Press the **[ENT]** key. **[-----]** is displayed for approximately two seconds.

[C-End]

Step 7 **[C-End]** is displayed.

[C-SET]

Step 8 Press the **[ESC]** key. **[C-SET]** is displayed and the calibration data is stored in the memory.

Step 9 The current state is the same as that of step 2. If returning to the weighing mode, press the **[ESC]** key.

- If **[C Er X]** is displayed, an error has occurred. Refer to “5.3.8. Error Codes For The Calibration” to take some measures. X : number.
- The blinking decimal point means that the current value is not the weight value.

5.3.3. Gravity Acceleration Correction

- When the scale (module) has been calibrated in the same place as it is being used, gravity acceleration correction is not required.
- A span error will appear if there is a gravity acceleration difference between the place where the module has been calibrated and the place where it is being used. The gravity acceleration correction calculates and corrects this span error by these gravity acceleration correction values for both points (the place it was calibrated and the place it is being used in).

Note When the span is calibrated with actual load calibration, the gravity acceleration correction settings are cleared, and the two gravity acceleration settings return to their default values.

- **Functions Related To The Gravity Acceleration Correction**
 - **CAL26**(Gravity acceleration of place of calibration) : The gravity acceleration where the module has been calibrated.
 - **CAL27**(Gravity acceleration of place of use) : The gravity acceleration where the module is being used.

Gravity Acceleration Table

Amsterdam	9.813 m/s ²	Manila	9.784 m/s ²
Athens	9.800 m/s ²	Melbourne	9.800 m/s ²
Auckland NZ	9.799 m/s ²	Mexico City	9.779 m/s ²
Bangkok	9.783 m/s ²	Milan	9.806 m/s ²
Birmingham	9.813 m/s ²	New York	9.802 m/s ²
Brussels	9.811 m/s ²	Oslo	9.819 m/s ²
Buenos Aires	9.797 m/s ²	Ottawa	9.806 m/s ²
Calcutta	9.788 m/s ²	Paris	9.809 m/s ²
Chicago	9.803 m/s ²	Rio de Janeiro	9.788 m/s ²
Copenhagen	9.815 m/s ²	Rome	9.803 m/s ²
Cyprus	9.797 m/s ²	San Francisco	9.800 m/s ²
Djakarta	9.781 m/s ²	Singapore	9.781 m/s ²
Frankfurt	9.810 m/s ²	Stockholm	9.818 m/s ²
Glasgow	9.816 m/s ²	Sydney	9.797 m/s ²
Havana	9.788 m/s ²	Tainan	9.788 m/s ²
Helsinki	9.819 m/s ²	Taipei	9.790 m/s ²
Kuwait	9.793 m/s ²	Tokyo	9.798 m/s ²
Lisbon	9.801 m/s ²	Vancouver, BC	9.809 m/s ²
London (Greenwich)	9.812 m/s ²	Washington DC	9.801 m/s ²
Los Angeles	9.796 m/s ²	Wellington NZ	9.803 m/s ²
Madrid	9.800 m/s ²	Zurich	9.807 m/s ²

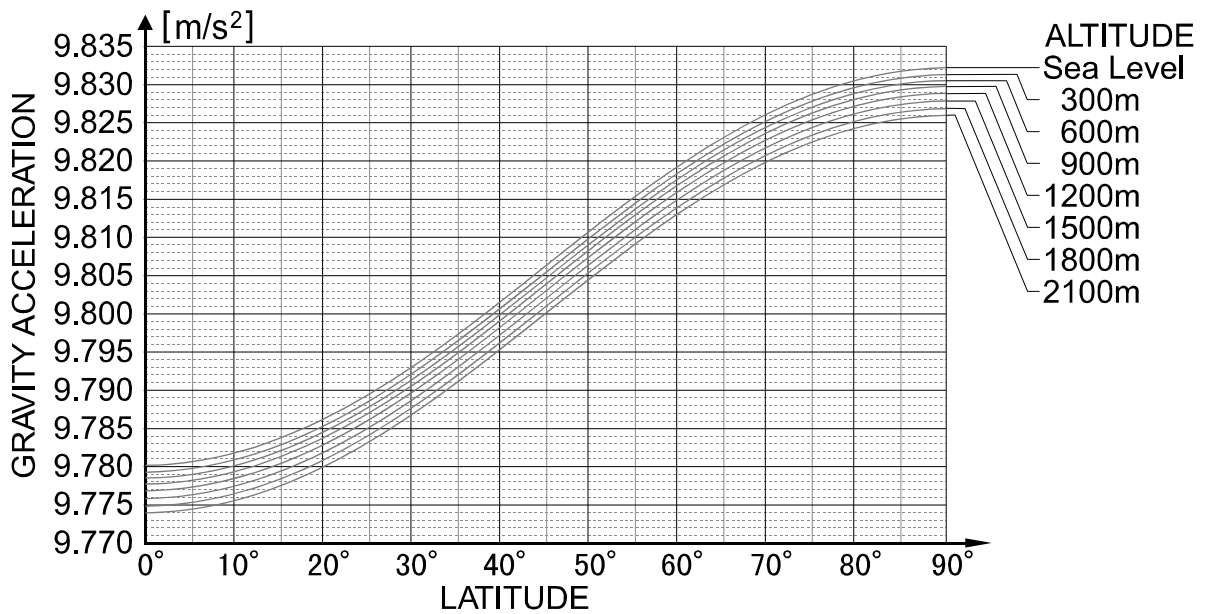

Illustration 8 Gravity Acceleration Graph

5.3.4. Outline Of The Linearization Function

Even if zero and span points have been calibrated, weighing errors may occur between the zero point and weighing capacity. This is a corrective function designed to non-linearly correct weighing errors.

- It is possible to input up to four points in addition to the zero point.
- The zero point and each input point will be corrected to put them in a straight line.
- Areas between input points that could not be corrected completely with straight line correction or with secondary correction will be corrected using a curved line derived from high-order equations.
- When the actual load input for digital linearization is performed, the calibrated data will be refreshed using zero point and final input point data. It is not necessary to calibrate again.

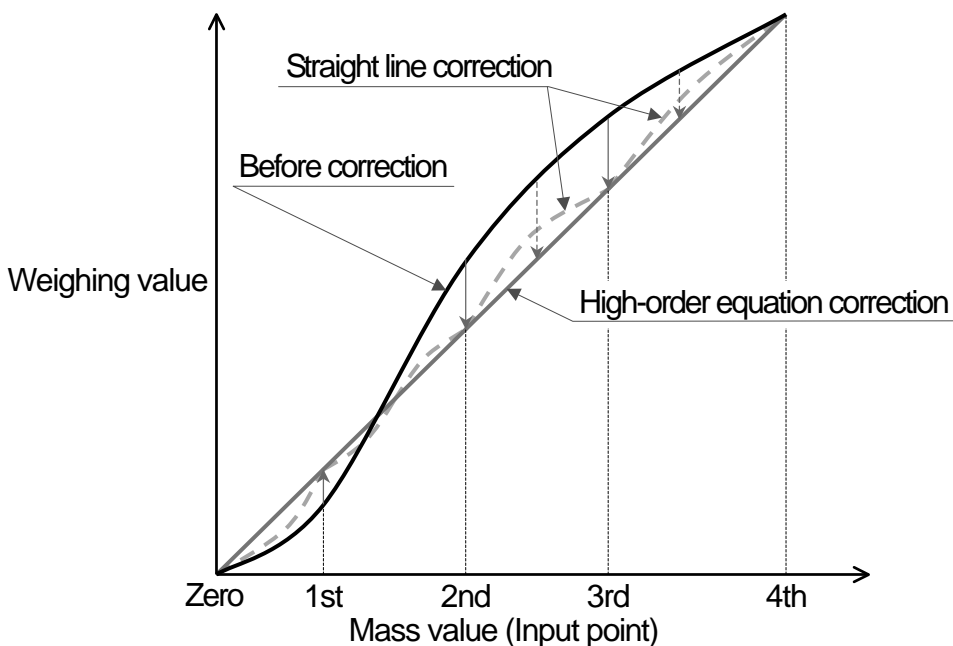

Illustration 9 Digital linearization

5.3.5. The Actual Load Linearization Function

Set the digital linearization by loading/unloading masses.

- Warm up the module for at least ten minutes to avoid the effects of temperature drift.
- The input order should proceed from the smallest mass to the largest mass.

Step 1 Press the **F** + **ENT** key to enter to the calibration mode and display **CAL**. Press the **ENT** key to start the calibration and display **L-SET**. Select **L-SET** using the **↑** key and press the **ENT** key.

CAL

L-SET

L-SET

Lnr 0

Step 2 **Lnr 0** is displayed.

If monitoring the current weighing value, press the **→** key.

When pressing the **→** key again, **Lnr 0** is display.

Step 3 Placed nothing on the pan and wait for the stabilization (**S** LED). Press the **ENT** key. **-----** is displayed for approximately two seconds.

Step 4 **Lnr 1** is displayed.

If you want to check the current weighing value, press the **→** key.

When pressing the **→** key again, **Lnr 1** is displayed.

Press the **ENT** key. The weight value (the current weighing capacity) is displayed and the least digit of the value blinks.

Correct the value using the **→** and **↑** key so as to be the weight value used.

Lnr 1

02000

00100

Example

Step 5 Place the weight on the pan. Wait for the stabilization (**S** LED). Press the **ENT** key. **-----** is displayed for approximately two seconds.

Step 5 **Lnr 2** is displayed. Repeat step 4 and step 5. The procedure proceeds in order of **Lnr 3** → **Lnr 4** → **L-End**.

Lnr 2

L-End

Step 7 If finishing the input, proceed to step 8. If you want to re-input the digital linearization, select the input point using the **↑** key. All data following the new input point will be cleared.

Step 8 Press the **ESC** key. **L-SET** is displayed and the inputted data will be stored in the FRAM. At the same time, the calibrated data is also refreshed. Press again the **ESC** key to return to weighing mode.

L-SET

- If **L Er X** is displayed, an error has occurred. X : number. Refer to "5.3.8. Error Codes For The Calibration" to take some measures.
- The blinking decimal point means that the current value is not the weight value.

5.3.6. The Function $\boxed{[-Fn]}$ Related To The Calibration

Step 1 Press the \boxed{F} + \boxed{ENT} key to enter to the calibration mode and display \boxed{CAL} .
Press the \boxed{ENT} key to start the calibration and display $\boxed{[-SEt]}$.

Step 2 Select $\boxed{[-Fn]}$ using the $\boxed{\uparrow}$ key and press the \boxed{ENT} key.

Step 3 Select a desired function number using the $\boxed{\uparrow}$ key and press the \boxed{ENT} key.
The current data is displayed.

Step 4 When changing data, two methods of parameter selection and digital input depending on the function are available.

Type	Description of method to change data
Parameter selection	Only the available parameter is displayed and blinks. Select a number using the $\boxed{\uparrow}$ key.
Digital input	All the digits are displayed and a digit to be changed blinks. Select a digit using the $\boxed{\rightarrow}$ key and change the value using the $\boxed{\uparrow}$ key.

After changing data, press the \boxed{ENT} key. The next function number is displayed.
When the value is not to be changed, press the \boxed{ESC} key to return to the function number display.

Step 5 Press the \boxed{ESC} key to store new data in FRAM and $\boxed{[-Fn]}$ is displayed.
Press again the \boxed{ESC} key to return to the weighing mode.

- The blinking decimal point means that the current value is not the weight value.
- If a data exceeding the available range is inputted, \boxed{Errdt} is displayed and data is canceled.

Function No. Parameter and range	Function name	Description	Default value
CAL02 0 to 0.0000	Decimal point position	Decimal point position of the weight value 0 0.000 0.0 0.0000 0.00	0
CAL03 1 to 50	Minimum division	Minimum division (d) of the weight value 1 10 2 20 5 50	1
CAL04 1 to 99999	Weighing capacity	Weighing capacity of the module. Weighing is possible up to the value of this setting plus 8 d. If the value exceeds this, overflow will occur and will not be displayed. The decimal point position is the same as the setting of CAL02 .	70000
CAL05 0 to 100	Zero adjustment range	Range to enable zero adjustment by the  key Expressed as a percentage of the weighing capacity with the calibration zero point as the center. For example, if this is set to 2, the value in the range of $\pm 2\%$ of the weighing capacity with the calibration zero point at the center will be to zero. When a power-ON zero is performed, the initial zero point will be the center.	2
CAL06 0.0 to 5.0	Zero tracking time	Performs zero tracking using this setting in combination with the setting of the zero tracking band CAL07 . When 0.0, zero tracking will not be performed. Unit : Second in 0.1 increments.	0.0
CAL07 0.0 to 9.9	Zero tracking band	Performs zero tracking using this setting in combination with the setting of the zero tracking time CAL06 . When 0.0, zero tracking will not be performed. Unit : d (minimum division) in 0.1 increments.	0.0

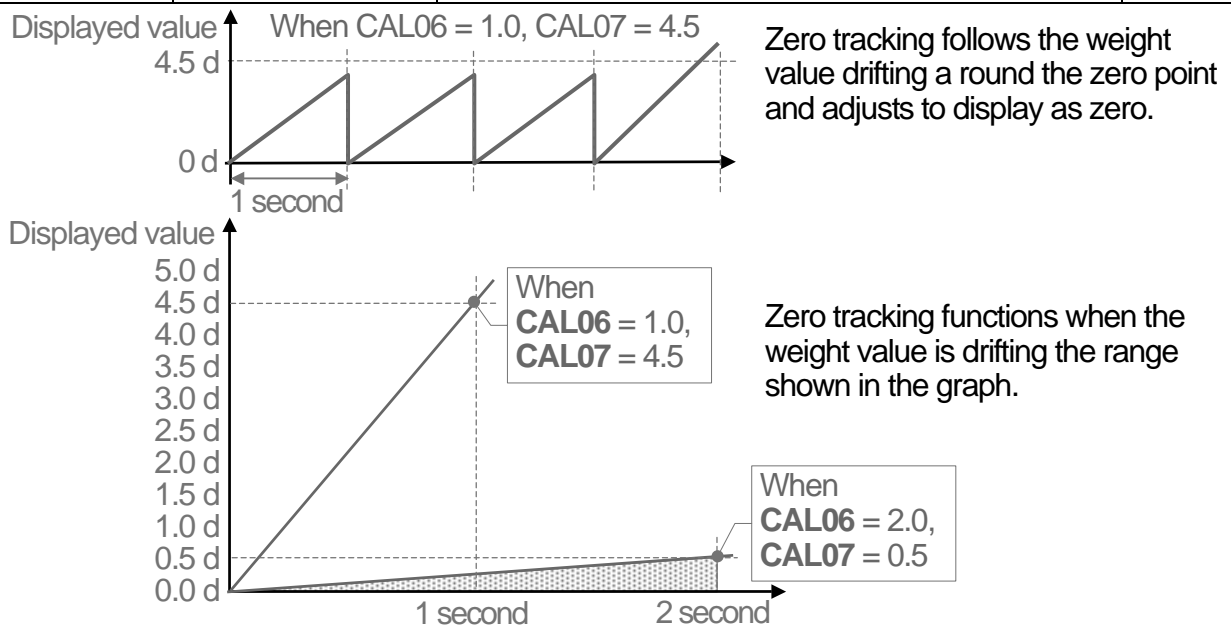

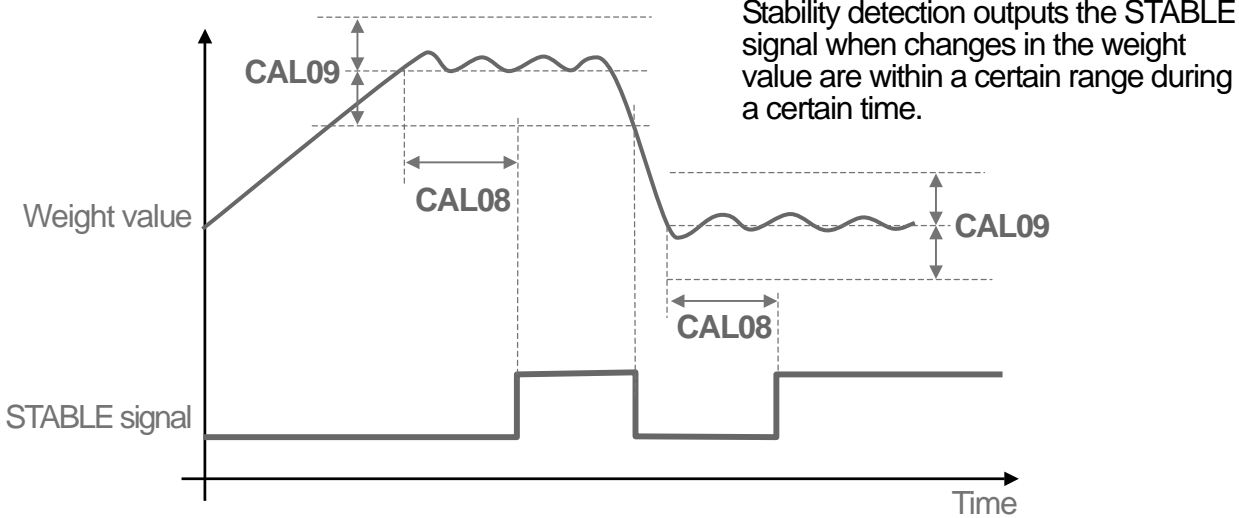
Function No. Parameter and range	Function name	Description	Default value
CAL08 0.0 to 9.9	Stability detection time	Performs stability detection using this setting in combination with the setting of the stability detection band CAL09 . When 0.0, stability detection will not be performed. (Stable all the time) Unit : Second in 0.1 increments.	1.0
CAL09 0 to 9	Stability detection band	Performs stability detection using this setting in combination with the setting of the stability detection time CAL08 . When 0, stability detection will not be performed. (Stable all the time) Unit : d (minimum division).	2
			
CAL10 0 to 1	Tare and zero adjustment when unstable	Tare and zero adjustment when the weight value is unstable. 0 : Disables both functions. 1 : Enables both functions.	1
CAL11 0 to 1	Tare when the gross weight is negative	Tare when the gross weight is negative. 0 : Disables tare. 1 : Enables tare.	1
CAL12 0 to 1	Output when overflow and unstable	Standard serial output when the weight value overflows and is unstable. 0 : Disables output. 1 : Enables output.	1
CAL13 1 to 3	Exceeding negative gross weight	To judge when the negative gross weight is exceeded. 1 : Gross weight < -99999 2 : Gross weight < Negative weighing capacity 3 : Gross weight < -19d	1
CAL14 1 to 2	Exceeding negative net weight	To judge when the negative net weight is exceeded. 1 : Net weight < -99999 2 : Net weight < Negative weighing capacity	1
CAL15 0 to 1	Clear the zero value	Select whether or not to clear the zero value. 0 : Disables. 1 : Enables.	1

Function No. Parameter and range	Function name	Description	Default value
CAL16 0 to 1	Zero setting when power is turned on	Select whether or not to perform zero setting when power is turned on. 0 : Disables. 1 : Enables.	0
CAL17 -7.0000 to 7.0000	Input voltage at zero	Input voltage from a load cell at zero. Unit : mV/V. This value is determined in zero calibration during the calibration with an actual load.	0.0000
CAL18 0.0001 to 9.9999	Input voltage at span	Input voltage from a load cell at span. Unit : mV/V. This value and the value of CAL19 are determined in span calibration during the calibration with an actual load.	3.2000
CAL19 1 to 99999	Calibration weight value corresponding to Input voltage at span	The calibration weight value corresponding to the Input voltage at span of CAL18 . When performing digital span, CAL17 , CAL18 and CAL19 are required. The decimal point position is the same as the setting of CAL02 .	32000
<p>NOTE:</p> <p>*1 Record the setting values of CAL17, CAL18 and CAL19 in the “Setting List” at the end of the manual to prepare against a failure.</p> <p>*2 By changing the parameters of CAL17, CAL18 and CAL19, “zero calibration” and “span calibration” can be adjusted optionally. (Digital span accuracy approximately 1/5000. The accuracy varies depending on the load cell output accuracy and the conditions of calibration.)</p> <p>Except for an emergency, perform calibration with an actual load.</p>			
CAL26 9.7500 to 9.8500	Gravity acceleration of place of calibration	Gravity acceleration of the place of calibration. Unit : in m/s^2 .	9.8000
CAL27 9.7500 to 9.8500	Gravity acceleration of place of use	Gravity acceleration of the place where the scale is being used. Unit : in m/s^2 .	9.8000
CAL28 0 to 1	Disable hold	0 : Disables. 1 : Enables.	0

5.3.7. The Function $L-F_{nc}$ Related To The Linearization Function

- Confirm and change linearity settings.
To use this function, select $L-F_{nc}$ in the same way as calibration-related functions are selected.

Function No. Parameter and range	Function name	Description	Default value
Lnr01 0 to 5	Number of input points	Number of points where linear input was done. The linear-zero input is included as one point. Digital linearization is not performed when the set value is between 1 and 2.	0
Lnr02 -7.0000 to 7.0000	Linear-zero	Voltage for linear-zero input. Unit : mV/V.	0.0000
Lnr03 0 to 99999	Linear 1 Mass value	The mass value for linear 1 input. The decimal point position depends on CAL02 .	0
Lnr04 0.0000 to 9.9999	Linear 1 Span	The span voltage between linear-zero and linear 1 input. Unit : mV/V.	0.0000
Lnr05 0 to 99999	Linear 2 Mass value	The mass value for linear 2 input. The decimal point position depends on CAL02 .	0
Lnr06 0.0000 to 9.9999	Linear 2 Span	The span voltage between linear-zero and linear 2 input. Unit : mV/V.	0.0000
Lnr07 0 to 99999	Linear 3 Mass value	The mass value for linear 3 input. The decimal point position depends on CAL02 .	0
Lnr08 0.0000 to 9.9999	Linear 3 Span	The span voltage between linear-zero and linear 3 input. Unit : mV/V.	0.0000
Lnr09 0 to 99999	Linear 4 Mass value	The mass value for linear 4 input. The decimal point position depends on CAL02 .	0
Lnr10 0.0000 to 9.9999	Linear 4 Span	The span voltage between linear-zero and linear 4 input. Unit : mV/V.	0.0000

5.3.8. Error Codes For The Calibration

When an error occurs during calibration, the error number is displayed.

If calibration is finished without removing the error, the setting values will be restored to the state before calibration.

Calibration errors and remedies

Error No.	Description	Treatment
C Er1	The display resolution (weighing capacity / minimum division) exceeds the specified value.	Make the minimum division greater or make the weighing capacity smaller. The specified value depends on specifications of the weighing system.
C Er2	Voltage at zero calibration exceeds in the positive direction.	Check the load cell rating and connection. When nothing is wrong with the rating and connection, adjust the load cell output as described in the next section. When the load cell or A/D converter may be the cause of error, confirm this by using the check mode.
C Er3	Voltage at zero calibration exceeds in the negative direction.	
C Er4	The value of the calibration weight exceeds the weighing capacity.	Use an appropriate calibration weight and calibrate again.
C Er5	The value of the calibration weight is less than the minimum division.	
C Er6	The load cell sensitivity is not sufficient.	Use a load cell with higher sensitivity or make the minimum division greater.
C Er7	Voltage at span calibration is less than voltage at the zero point.	Check the load cell connection.
C Er8	The load cell output voltage is too high when the load of the weighing capacity is placed.	Use a load cell with a greater rating or make the weighing capacity smaller.

5.3.9. Adjustment Of The Loadcell Output

Add a resistor as shown below to adjust the load cell output.

Use a resistor with a high resistance value and a low temperature coefficient.

"C Er2"

When exceeding in the positive direction.

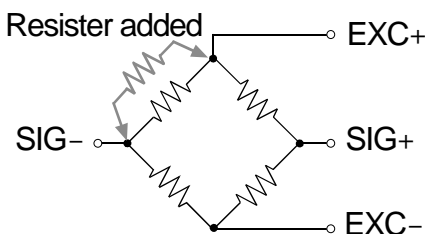

"C Er3"

When exceeding in the negative direction.

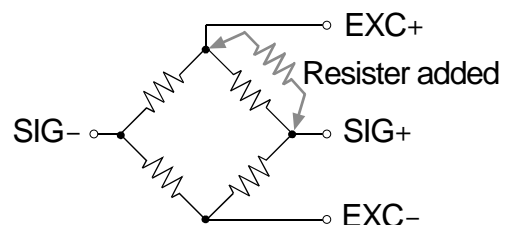

Illustration 10 Load cell output adjustment

- Because the zero point of the module has a wide adjustable range, as long as there is no problem with a load cell, correcting an output by the module is hardly ever required. Before an output correction is carried out, confirm load cells (deformation, wiring mistakes, contact with anything, or model selection etc.) and connections.

5.4. General Functions

- In this section, the way of pre-setting and descriptions for the general functions is described. General functions are divided into groups according to function and are indicated by the group name with the function number.

NOTE: General functions determine the module performance and all of the settings are stored in the FRAM.

5.4.1. The Procedure To Store New Parameters

Step 1 Press the **ENT** + **F** key to enter to the function mode and display **Fnc**.
Press the **ENT** key to start the function mode.
If returning to the weighing mode, press the **ESC** key.

Step 2 Press the **↑** key to select the function group to be set.
Press the **ENT** key. The function group is as follows :

Display	Group Name
<i>L-Fnc</i>	Basic functions
<i>HLd</i>	Hold functions
<i>bCd</i>	BCD Interface

Step 3 Press the **↑** key to select the function number to be set.
Press the **ENT** key. The current setting value is displayed.

Step 4 When changing data, two methods of parameter selection and digital input depending on the function are available.

Type	Description of method to change data
Parameter selection	Only the available parameter is displayed and blinks. Select a number using the ↑ key.
Digital input	All the digits are displayed and a digit to be changed blinks. Select a digit using the → key and change the value using the ↑ key.

After changing data, press the **ENT** key. The next function number is displayed.
When the value is not to be changed, press the **ESC** key to return to the function number display.

Step 5 Press the **ESC** key to return to **Step 2**.
Press the **ESC** key once to store new data in FRAM and to return to the weighing mode.

- The blinking decimal point means that the current value is not the weight value.
- If a data exceeding the available range is inputted, **Errdt** is displayed and data is canceled.

5.4.2. The Adjustment Of The Digital Filter

Adjust the digital filter using **Fnc05** (digital filter).

The available settable range for the cutoff frequency is from 100 Hz to 0.7 Hz.

The cut off frequency is the frequency where vibrations declines to $1/\sqrt{2}$ times.

- If the weighing value is unstable, set the cutoff frequency lower.
- To make the response faster, set the cutoff frequency higher.

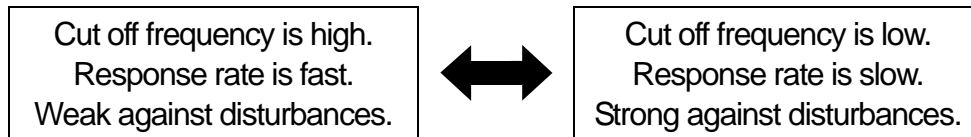

- It is possible to make adjustments while watching the effects of the digital filter with your own eyes.
- By pressing the  key while setting **Fnc05** (digital filter), it is possible to check the weight displayed.

 key Increase stability.

 key Return to the value setting display.

Function No. Parameter and range	Function name	Description	Default value
Fnc09 1 to 2	Mass to be compared with near-zero	Item to be compared with near-zero. 1 : Gross weight 2 : Net weight	1
Fnc10 -99999 to 99999	Set value of upper limit	Reference value for the upper limit. Decimal point position is linked to CAL02 .	10
Fnc11 -99999 to 99999	Set value of lower limit	Reference value for the lower limit. Decimal point position is linked to CAL02 .	-10
Fnc12 1 to 2	Mass to be compared with upper and lower limit	Item to be compared with the upper and lower limit. 1 : Gross weight 2 : Net weight	1
Fnc13 1 to 2	Output logic of upper and lower limit	Logic used when the result of the comparison with the upper and lower limit is output 1 : Positive logic 2 : Negative logic	1

5.4.4. The List Of The Hold Function

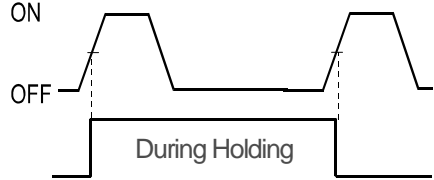
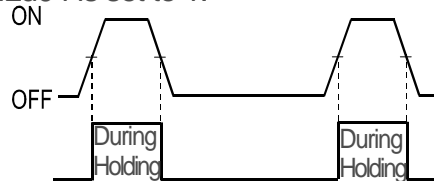
Function No. Parameter and range	Function name	Description	Default value
HLd01 0.00 to 9.99	Averaging time	Time to perform the averaging. Unit : second. 0.00 is not averaged.	0.00
HLd02 0.00 to 9.99	Start wait time	Time to wait before commencing hold or averaging. Unit : second.	0.00
HLd03 0 to 2	Condition of automatic start	Condition to start the hold or averaging automatically. 0 : Do not use automatic start. 1 : Above the near-zero range, and stable. 2 : Above the near-zero range.	0
HLd04 0 to 1	Release due to falling control input	Release when control input is falling. 0 : Do not release 1 : Release When the Hld04 is set to 0.  When the HLd04 is set to 1. 	1
HLd05 0.00 to 9.99	Time release	Release after a set amount of time has passed. Unit : second. 0.00 is not averaged.	0.00
HLd06 0 to 99999	Release due to range of fluctuation	Release when fluctuation from the holding value exceeds a set value. The decimal point position is the same as the setting of CAL02 .	0
HLd07 0 to 1	Release in near-zero range	Release when the weighing value is in the near-zero range. 0 : Do not release. 1 : Release.	0

- This hold function only works when **Fnc07** (hold) is set to 2 (peak hold) or 3 (averaging hold). This hold function has no function when **Fnc07** (hold) is set to 1 (normal hold).
- **HLd01** (averaging time) works only when **Fnc07** (hold) is set to 3 (averaging hold).

5.4.5. The List Of The BCD Function

Function No. Parameter and range	Function name	Description	Default value
bcd01 1 to 4	Output data	1 : Displayed weight 2 : Gross weight 3 : Net weight 4 : Data specified by BCD input	1
bcd02 1 to 3	Data transfer mode	1 : Stream 2 : Automatic printing 3 : Manual printing	1
bcd03 5 to 1000	Data transfer rate	5 times/second 10 times/second 20 times/second 100 times/second 1000 times/second } Display linked to Fnc03	20
bcd04 1 to 2	Output logic of data transfer	1 : Negative logic 2 : Positive logic	2
bcd05 1 to 2	Output logic of negative sign	1 : Negative logic 2 : Positive logic	2
bcd06 1 to 2	Output logic of status	1 : Negative logic 2 : Positive logic	2
bcd07 1 to 2	Output logic of strobe	1 : Negative logic 2 : Positive logic	2
bcd08 0 to 5	Input selection	0 : None 1 : Clear zero 2 : Clear tare 3 : Changing between gross weight and net weight 4 : Print command 5 : [F] key	3
bcd09 0 to 12	Output selection	0 : None 1 : Stabilization 2 : During tare 3 : Zero band 4 : Hold busy state 5 : HI output (Over upper limit) 6 : OK output (Within upper and lower limits) 7 : LO output (Under lower limit) 8 : During operating weighing (On) 9 : During operating weighing (1 Hz) 10 : During operating weighing (50 Hz) 11 : Alarm (Zero correction error and tare error) 12 : Busy [F] key	1

6. Interface

6.1. The Parallel BCD Output

6.1.1. Timing Chart Of The BCD Output

The strobe signal becomes "1" when starting data transmission and becomes "2" after the strobe time. The strobe pulse band takes half the time to transmit data.

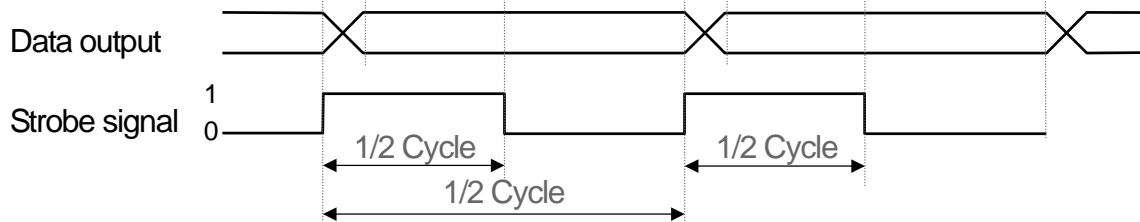

6.1.2. Terminals Of The BCD Output

BCD Output And I/O Output

Output type	Open Collector
Isolation	Photo coupler
Output current	50mA max.
Saturation voltage	0.5V max. @50mA

I/O Input

Input type	DC input
Open circuit voltage	Approx. 5V
Off current	0.1mA max.
On current	2mA min.
Saturation voltage	2V
Anti - chattering time	10msec.

The circuit of BCD is isolated from the D.C. power supply and load cell circuit.

Supply D.C. +24 V between BCD PWR+24V terminal and COM terminal.

INPUT						OUTPUT
	ZERO	36		18	GRS/NET	
	TARE	35		17	SELECT	
	HOLD	34		16	DIAGNOS	
	SELECT	33		15	100	
	HOLD	32		14	200	
	NET DISP	31		13	400	
	OVER	30		12	800	
	MINUS	29		11	1000	
	1	28		10	2000	
	2	27		9	4000	
	4	26		8	8000	
	8	25		7	10000	
	10	24		6	20000	
	20	23		5	40000	
	40	22		4	80000	
	80	21		3	STROBE	
	BCD PWR	20		2	COM	
	+24V	19		1		

6.1.3. The State Of The BCD Output

Over Flow

The whole bits of the weighing data (1×10^0 to 8×10^4) are set to "1". Negative sign and status bits are according to the situation.

Except Weighing Mode

The whole bits of the weighing data (1×10^0 to 8×10^4) are set to "1". Over bit is set to "1". Other bits are set to "0". The strobe signal is not output. A strobe signal is output once when moving the mode from weighing mode with stream mode.

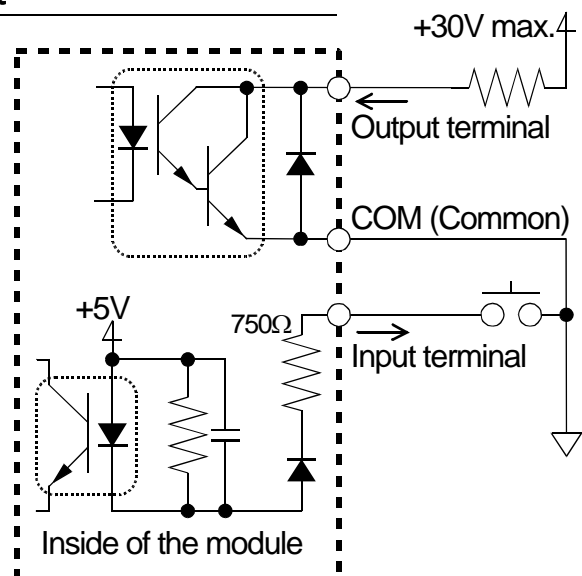

6.1.4. Positive Logic And Negative Logic

Negative Logic (A-Contact: Normally open) And Positive Logic (B-Contact: Normally closed)

The AD-4430B can select the output logic of the output terminals.

The output terminal is conductive in negative logic (A-Contact: Normally open) when the output signal is "1".

The output circuits of the AD-4430B are an open collector as shown below.

ex. The MINUS output terminal

To light the load LED when the BCD output value is minus, select the negative logic in the "5.4.5 The List Of The BCD Function".

When the power is off, both output terminal logics become non-conductive.

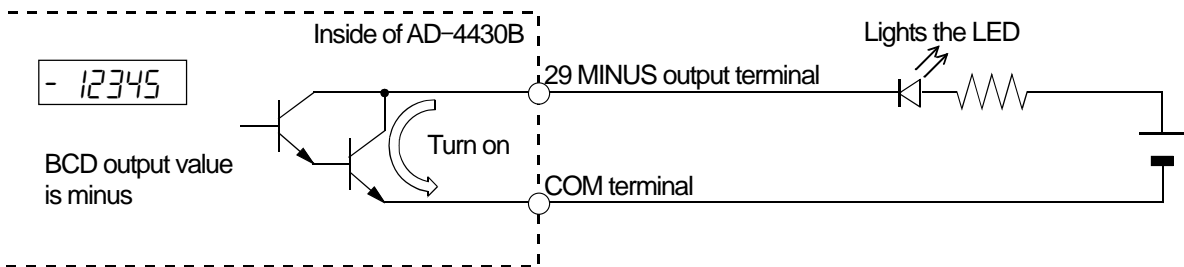

Output logic and behavior (ex. MINUS output terminal)

Output logic	Behavior	Example
Negative logic (A-contact: Normally open) bcd05 = 1	The MINUS output terminal is conductive when the BCD output value is minus.	The load LED is lit when the BCD output value is minus.
Positive logic (B-contact: Normally closed) bcd05 = 2	The MINUS output terminal is non-conductive when the BCD output value is minus.	The load LED is lit when the BCD output value is plus or zero.

7. Maintenance

7.1. Error Messages

If an error message is displayed, refer to the chart below to take proper measures.

Error message	Cause	Treatment
<i>C5 Er</i>	Program checksum error.	Repair is required.
<i>Ad Er</i>	Data can not be acquired from the A/D converter.	Repair is required.
<i>FrAEr</i>	Correct data can not be read from the FRAM.	Perform initialization. If initialization does not clear the error, repair is required.
<i>C Err</i>	Calibration data is not correct.	Perform calibration.
<i>C Er X</i>	Calibration error. X : number.	Refer to "5.3.8. Error Codes for the Calibration".
<i>Errdt</i>	The setting value is out of the settable range.	Check the setting value and set again.

7.2. Verifying The Load Cell Connections (DIAGNOS)

7.2.1. Guideline To Verify The Load Cell Connections

The faulty wiring or disconnection of the load cell can be checked.

This verification is useful for new setting, pre-measurement inspection and periodical inspection.

No.	Check Item	Target	Judgment Criteria (Generally)
1	Load cell input voltage	Between SEN+ ⇔ SEN-	3 V or more
2	SEN+ voltage	Between SEN+ ⇔ AGND	4 V or more
3	SEN- voltage	Between SEN- ⇔ AGND	1 V or less
4	Load cell output voltage	Between SIG+ ⇔ SIG-	Within ±35 mV
5	Load cell output rate	Between SIG+ ⇔ SIG-	Within ±7 mV/V
6	SIG+ voltage	Between SIG+ ⇔ AGND	1 V to 4 V
7	SIG- voltage	Between SIG- ⇔ AGND	1 V to 4 V
8	Internal temperature		-20 °C to +60 °C

AGND : Internal analog circuit ground

SIG- : Load cell output (-)

SIG+ : Load cell output (+)

EXC- : Load cell input (-)

SEN- : Sensing input (-)

SEN+ : Sensing input (+)

EXC+ : Load cell input (+)

SHLD : Shield. Frame ground.

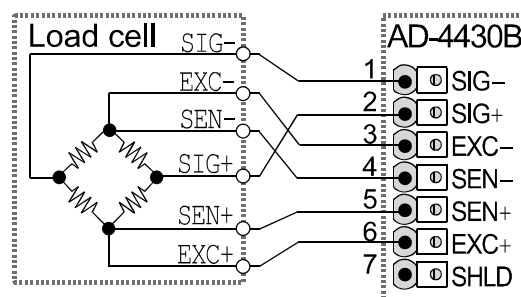

Illustration 11 Wire Name of Load Cell

7.2.2. The Operation With The BCD Input

When inputting "ON" level to the "DIAGNOS" terminal of the BCD input terminal for 1 second or more, the self-check mode is started and each results are displayed and outputted. The scan condition of the self-check mode can be specified by the following BCD input.

BCD Input

No.	DIAGNOS	GRS/NET	HOLD	TARE	ZERO
Scan	ON	OFF	OFF	OFF	OFF
1	ON	OFF	OFF	OFF	ON
2	ON	OFF	OFF	ON	OFF
3	ON	OFF	OFF	ON	ON
4	ON	OFF	ON	OFF	OFF
5	ON	OFF	ON	OFF	ON
6	ON	OFF	ON	ON	OFF
7	ON	OFF	ON	ON	ON
8	ON	ON	OFF	OFF	OFF

7.2.3. The Operation With The Switch

- Step 1** Press the **[F]** key while pressing and holding the **[ENT]** key (**[ENT]** + **[F]**) to display **[Fnc]**. Press the **[ENT]** key to enter to the function mode.
If returning to the weighing mode, press the **[ESC]** key.
- Step 2** Press the **[→]** key while pressing and holding the **[ENT]** key (**[→]** + **[ENT]**) to display **[Chc]** of the check mode. Press the **[ENT]** key to display the check item.
- Step 3** Select the self-check mode **[d,RC]** using the **[↑]** key. Press the **[ENT]** key to enter to it. The selected check is performed and displayed the results for approx. 16 seconds. Each measurement value can be displayed using the **[↑]** key.

7.2.4. The Result Of Verifying The Connection

While doing the scan and display exchange, **[d,RC]** is displayed and **[99999]** is outputted. The result of scan is displayed a value **XXX** added error codes.

When an error is nothing, **[Good]** is displayed and **[00000]** is outputted.

When detecting an error, **[ErXXX]** is displayed and **[00XXX]** is displayed a value. **XXX** is added error codes. BCD output is not included decimal point. The resistance of the load cell cable can be calculated as follows : (Resister value of the load cell) × (No.3) / (No.1)

No.	Check item	Status LED	Display Range	Error Code
		G N H S Z X		
1	Load cell input voltage	○ ○ ● ● ● ○	0.001 V	1
2	SEN+ voltage	○ ○ ● ● ○ ●	0.001 V	2
3	SEN- voltage	○ ○ ● ● ○ ○	0.001 V	4
4	Load cell output voltage	○ ○ ● ○ ● ●	0.001 mV	8
5	Load cell output rate	○ ○ ● ○ ● ○	0.0001 mV/V	16
6	SIG+ voltage	○ ○ ● ○ ○ ●	0.001 V	32
7	SIG- voltage	○ ○ ● ○ ○ ○	0.001 V	64
8	Internal temperature	○ ○ ○ ● ● ●	0.1 °C	128

○ : lighted ● : not lighted

7.3. Check Mode

The check mode checks the performance of the display, key switches and external I/O.

7.3.1. Entering The Check Mode

- Step 1** Press the **[F]** key while pressing and holding the **[ENT]** key (**[ENT]** + **[F]**) to display **[Fnc]**.
If returning to the weighing mode, press the **[ESC]** key.
- Step 2** Press the **[→]** key while pressing and holding the **[ENT]** key (**[→]** + **[ENT]**) to display **[Hc]** of the check mode. Press the **[ENT]** key to display the check item
- Step 3** Select the check item using the **[↑]** key. Press the **[ENT]** key to enter to it.
Press the **[ESC]** key when exiting it

Display	Item To Be Checked
[HKEY]	Key check
[Hbcd]	BCD check
[H Ad]	A/D converter output check (Load cell)
[H in]	Internal count
[HPrG]	Program version
[H Sn]	Serial number
[SPrG]	Program checksum
[SFrA]	Memory checksum (EEPROM)
[F dt]	CALF check (CAL01 to CAL28)

7.3.2. Verifying The Switch Operation

When pressing the key, the corresponding segment moves.
If stopping the current check mode, press the **[ESC]** key twice.

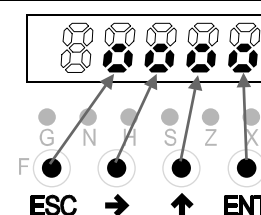

7.3.3. Checking The BCD Output

An output value of the BCD is displayed in unit of one bit.
ex. If BCD output is 400.
Also, depending on the IO input, the status mark illuminates.

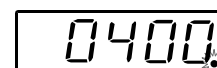

7.3.4. Monitoring The A/D Converter (For Load cell Output)

The load cell output voltage rate is displayed in unit of mV/V .

ex. If internal count is 1.2345 mV/V ,

If value is above ± 7 mV/V, a damage and connection error of the load cell may cause . Refer to "7.5. Verifying The Load cell Connections Using Multimeter".

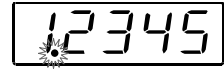

7.3.5. Monitoring The Internal Value

Internal count (10 times of weighing value) is displayed.

ex. If internal count is 123.

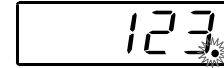

7.3.6. Monitoring The Program Version

Program version is displayed.

ex. If version is 1.00 .

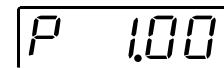

7.3.7. Monitoring The Serial Number

ex. If low five digits of serial number is displayed.

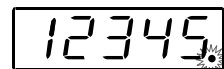

7.3.8. Monitoring The Checksum Of The Program

Checksum of the program is displayed.

ex. If checksum is EF.

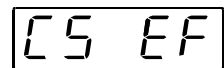

7.3.9. Monitoring The Checksum Of An Internal FRAM

Checksum of FRAM is displayed.

Memory of the general function is not checked

ex. If checksum is EF.

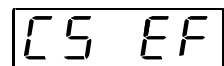

7.3.10. Displaying Function Parameters For Calibration

Function parameters rated to calibration can be displayed.

Note

- Concerning these operation and details, refer to "5.3.6. The Function $C-Fnc$ Related To The Calibration".
- Parameters can not be changed here.

7.4. Initializing Parameters

The initialization mode restores the parameters of the default values to the FRAM. Three types of initialization mode are available as shown below.

Initialization mode	Display	Description
RAM initialization	in i r	RAM memory is initialized. The center of zero and tare value will be restored to 0.
General functions initialization	in i F	Data of the general functions stored in the FRAM are reset to factor settings.
All data initialization	in i R	All data stored in the FRAM are initialized. So calibration data is included, calibrate the module again.

7.4.1. Initializing Mode For RAM And Function Parameters

- Step 1** Press the **F** key while pressing and holding the **ENT** key (**ENT** + **F**) to display **Fnc**. If returning to the weighing mode, press the **ESC** key.
- Step 2** Press the **→** key while pressing and holding the **ENT** key (**→** + **ENT**) to display **CHC** of the check mode.
- Step 3** Select the initialization mode **in i** using the **↑** key. Press the **ENT** key.
- Step 4** Select an item to be initialized using the **↑** key. Press the **ENT** key.
- Step 5** Check that all status LED are blinking.
If performing the initialization, press the **ENT** key for 3 seconds or more.
After initialization, all segments light and return to the weighing mode.
If canceling the initialization, press the **ESC** key return to the weighing mode.

7.4.2. Initializing The Whole Data

- Step 1** In the standby mode (While turning off the module), Press **F** + **ENT** key to display **CAL**.
If returning to the weighing mode, press the **ESC** key.
- Step 2** Press the **ENT** key. to enter to calibration mode.
- Step 3** Select all initialization mode using the **↑** key. Press the **ENT** key.
- Step 4** Check that all status LED are blinking.
If performing the initialization, press the **ENT** key for 3 seconds or more.
After initialization, all segments light and return to the weighing mode.
If canceling the initialization, press the **ESC** key return to the weighing mode.

7.5. Verifying The Load cell Connections Using Multimeter

The load cell connection can be checked easily using a digital multimeter.

Illustration 12 Connection Check of Load Cell shows points to confirm the load cell connection.

When a summing box is used, the same measurement must be performed, even internally.

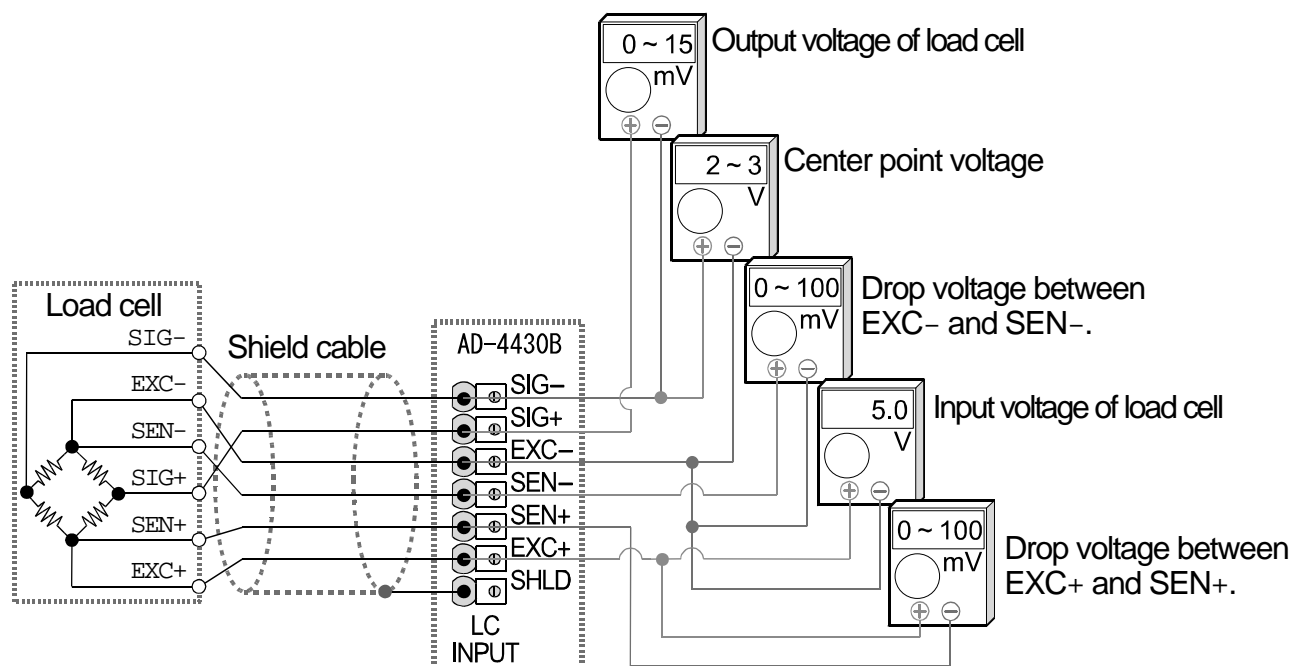

Illustration 12 Connection Check of Load Cell

7.5.1. Check List Of The Load cell Connections

Measurement Point	Item To Be Measured	Judging The Voltage
EXC+ : SEN+	A drop voltage of the load cell cable on EXC+ side.	Normally 100mV or less. However, it may exceed 1V when an extremely long load cell cable is used. For the 4-wire connection, it must be 0V.
EXC+ : EXC-	Input voltage of load cell	Normal range is between 4.75 V to 5.25 V.
SEN- : EXC-	A drop voltage of the load cell cable on EXC- side.	Normally 100mV or less. However, it may exceed 1V when an extremely long load cell cable is used. For the 4-wire connection, it must be 0V.
SIG- : EXC-	Center point voltage	Approximately 2.5 V of a half of excitation voltage.
SIG+ : SIG-	Output voltage of load cell	Generally within 0 V to 15mV. Theoretical value is calculated from the load cell rated capacity, actual load and excitation voltage.

When the module does not operate properly, write the required items in the table below and contact your local A&D dealer.

Item	User's Usage Circumstances Model Number, Rated, Measurement Value etc.	Description
Connection method	<input type="checkbox"/> 4-wire connection <input type="checkbox"/> 6-wire connection	When using the 4-wire connection, connect between EXC+ and SEN+ and between EXC- and SIG-.
Model number of load cells		
Rated capacity of load cells	[Unit]	
Rated output of load cells	[mV/V]	
Allowable overload of load cells	[%]	
Number of load cells used	[pieces]	
Use of summing box		
Length of the extension cable	[m]	Length from the module to the summing box.
Initial load on the module	[Unit]	
Weighing capacity of the module	[Unit]	Write all digits including decimal figures. Example : 0.002 kg
Weighing capacity of the module	[Unit]	Write all digits including decimal figures. Example : 10.000 kg
Load cell output during initial load (when no load is applied)	[mV/V]	From -0.1 mV/V to rated sensitivity value (With the first load)
Relation between load cell output and load of mass of capacity (or chosen mass)	Load : [Unit] Load cell output : [mV/V]	When loaded to capacity, the output value of the initial load + the rated output value of the load cell. (It must be within allowable overload.)

Measurement point		Measurement contents	Measurement result
EXC+	SEN+	A drop voltage of the load cell cable on EXC+ side.	[mV]
EXC+	EXC-	Input voltage of load cell	[V]
SEN-	EXC-	A drop voltage of the load cell cable on EXC- side.	[mV]
SIG-	EXC-	Center point voltage	[V]
SIG+	SIG-	Output voltage of load cell	[mV]

7.6. The Parameter List For The Function List

When performing maintenance, use the following list as a memorandum.

When making inquiries about the product, inform your local A&D dealer of the user settings.

7.6.1. Basic Functions

Function No. Parameter and range	Function name	Description	Default value	User setting	MEMO
Fnc01 0000 to 1111	Disable key switch	Each digit of the setting corresponds to a key switch. Only available in the weighing mode. 0 : Enables Key assignment to each binary digit. 1 : Disables 4th 3rd 2nd 1st <input type="checkbox"/> ESC <input type="checkbox"/> → <input type="checkbox"/> ↑ <input type="checkbox"/> ENT	0000 (binary)		
Fnc02 0 to 7	<input type="checkbox"/> F key	0 : None 1 : Manual print command 2 : Hold 3 : Alternate switch 4 : Momentary switch 5 : Changing between gross weight and net weight 6 : Clear the tare weight 7 : Clear the zero value NOTE: Clearing the zero value can be enabled or disabled by CAL15.	5		
Fnc03 5 to 20	Display update rate	20 times/second 10 times/second 5 times/second	20		
Fnc04 0 to 9	x display	0 : None 1 : Zero tracking in progress 2 : Alarm (Zero range setting error, over) 3 : <input type="checkbox"/> F key status 4 : Zero band 5 : HI output (Over the upper limit value) 6 : OK output (Between upper and lower limit values) 7 : LO output (Below the lower limit value) 8 : User input 1 9 : User output 1	0		
Fnc05 0 to 16	Digital filter	Selects a cutoff frequency. 0: None 1: 100.0 Hz 9: 7.0 Hz 2: 70.0 Hz 10: 5.6 Hz 3: 56.0 Hz 11: 4.0 Hz 4: 40.0 Hz 12: 2.8 Hz 5: 28.0 Hz 13: 2.0 Hz 6: 20.0 Hz 14: 1.4 Hz 7: 14.0 Hz 15: 1.0 Hz 8: 10.0 Hz 16: 0.7 Hz	15		
Fnc07 1 to 3	Hold	1 : Normal hold 2 : Peak hold 3 : Averaging hold	1		
Fnc08 -99999 to 99999	Set value of near-zero	The reference value for near-zero. Decimal point position is linked to CAL02 .	10		

Function No. Parameter and range	Function name	Description	Default value	User setting	MEMO
Fnc09 1 to 2	Mass to be compared with near-zero	Item to be compared with near-zero. 1 : Gross weight 2 : Net weight	1		
Fnc10 -99999 to 99999	Set value of upper limit	Reference value for the upper limit. Decimal point position is linked to CAL02 .	10		
Fnc11 -99999 to 99999	Set value of lower limit	Reference value for the lower limit. Decimal point position is linked to CAL02 .	-10		
Fnc12 1 to 2	Mass to be compared with upper and lower limit	Item to be compared with the upper and lower limit. 1 : Gross weight 2 : Net weight	1		
Fnc13 1 to 2	Output logic of upper and lower limit	Logic used when the result of the comparison with the upper and lower limit is output 1 : Positive logic 2 : Negative logic	1		

7.6.2. The List Of The Hold Function

Function No. Parameter and range	Function name	Description	Default value	User setting	MEMO
HLd01 0.00 to 9.99	Averaging time	Time to perform the averaging. Unit : second. 0.00 is not averaged.	0.00		
HLd02 0.00 to 9.99	Start wait time	Time to wait before commencing hold or averaging. Unit : second.	0.00		
HLd03 0 to 2	Condition of automatic start	Condition to start the hold or averaging automatically. 0 : Do not use automatic start. 1 : Above the near-zero range, and stable. 2 : Above the near-zero range.	0		
HLd04 0 to 1	Release due to falling control input	Release when control input is falling. 0 : Do not release 1 : Release	1		
HLd05 0.00 to 9.99	Time release	Release after a set amount of time has passed. Unit : second. 0.00 is not averaged.	0.00		
HLd06 0 to 99999	Release due to range of fluctuation	Release when fluctuation from the holding value exceeds a set value. The decimal point position is the same as the setting of CAL02 .	0		
HLd07 0 to 1	Release in near-zero range	Release when the weighing value is in the near-zero range. 0 : Do not release. 1 : Release.	0		

7.6.3. The List Of The BCD Function

Function No. Parameter and range	Function name	Description	Default value	User setting	MEMO
bcd01 1 to 4	Output data	1 : Weighing value 2 : Gross weight 3 : Net weight 4 : Data specified at BCD input	1		
bcd02 1 to 3	Data transfer mode	1 : Stream 2 : Automatic printing 3 : Manual printing	1		
bcd03 5 to 1000	Data transfer rate	5 times/second 10 times/second 20 times/second 100 times/second 1000 times/second } Display linked to Fnc03	20		
bcd04 1 to 2	Output logic of data transfer	1 : Negative logic 2 : Positive logic	2		
bcd05 1 to 2	Output logic of negative sign	1 : Negative logic 2 : Positive logic	2		
bcd06 1 to 2	Output logic of status	1 : Negative logic 2 : Positive logic	2		
bcd07 1 to 2	Output logic of strobe	1 : Negative logic 2 : Positive logic	2		
bcd08 0 to 5	Input selection	0 : None 1 : Clear zero 2 : Clear tare 3 : Changing between gross weight and net weight 4 : Print command 5 : F key	3		
bcd09 0 to 12	Output selection	0 : None 1 : Stabilization 2 : During tare 3 : Zero band 4 : Hold busy state 5 : HI output (Over upper limit) 6 : OK output (Within upper and lower limits) 7 : LO output (Under lower limit) 8 : During operating weighing (On) 9 : During operating weighing (1 Hz) 10 : During operating weighing (50 Hz) 11 : Alarm (Zero correction error and tare error) 12 : Busy F key	1		

7.6.4. The List Of The Calibration

Function No. Parameter and range	Function name	Description	Default value	User setting	MEMO
CAL02 0 to 0.0000	Decimal point position	Decimal point position of the weight value 0 0.00 0.0000 0.0 0.000	0		
CAL03 1 to 50	Minimum division	Minimum division (d) of the weight value 1 2 5 10 20 50	1		
CAL04 1 to 99999	Weighing capacity	Weighing capacity of the module. Weighing is possible up to the value of this setting plus 8 d. If the value exceeds this, overflow will occur and will not be displayed. The decimal point position is the same as the setting of CAL02 .	70000		
CAL05 0 to 100	Zero adjustment range	Range to enable zero adjustment by the →(ZERO) key Expressed as a percentage of the weighing capacity with the calibration zero point as the center. For example, if this is set to 2, the value in the range of ±2% of the weighing capacity with the calibration zero point at the center will be to zero. When a power-ON zero is performed, the initial zero point will be the center.	2		
CAL06 0.0 to 5.0	Zero tracking time	Performs zero tracking using this setting in combination with the setting of the zero tracking band CAL07 . When 0.0, zero tracking will not be performed. Unit : Second in 0.1 increments.	0.0		
CAL07 0.0 to 9.9	Zero tracking band	Performs zero tracking using this setting in combination with the setting of the zero tracking time CAL06 . When 0.0, zero tracking will not be performed. Unit : d (minimum division) in 0.1 increments.	0.0		
CAL08 0.0 to 9.9	Stability detection time	Performs stability detection using this setting in combination with the setting of the stability detection band CAL09 . When 0.0, stability detection will not be performed. (Stable all the time) Unit : Second in 0.1 increments.	1.0		
CAL09 0 to 9	Stability detection band	Performs stability detection using this setting in combination with the setting of the stability detection time CAL08 . When 0, stability detection will not be performed. (Stable all the time) Unit : d (minimum division).	2		
CAL10 0 to 1	Tare and zero adjustment when unstable	Tare and zero adjustment when the weight value is unstable. 0 : Disables both functions. 1 : Enables both functions.	1		
CAL11 0 to 1	Tare when the gross weight is negative	Tare when the gross weight is negative. 0 : Disables tare. 1 : Enables tare.	1		

Function No. Parameter and range	Function name	Description	Default value	User setting	MEMO
CAL12 0 to 1	Output when overflow and unstable	Standard serial output when the weight value overflows and is unstable. 0 : Disables output. 1 : Enables output.	1		
CAL13 1 to 3	Exceeding negative gross weight	To judge when the negative gross weight is exceeded. 1 : Gross weight < -99999 2 : Gross weight < Negative weighing capacity 3 : Gross weight < -19d	1		
CAL14 1 to 2	Exceeding negative net weight	To judge when the negative net weight is exceeded. 1 : Net weight < -99999 2 : Net weight < Negative weighing capacity	1		
CAL15 0 to 1	Clear the zero value	Select whether or not to clear the zero value. 0 : Disables. 1 : Enables.	1		
CAL16 0 to 1	Zero setting when power is turned on	Select whether or not to perform zero setting when power is turned on. 0 : Disables. 1 : Enables.	0		
CAL17 -7.0000 to 7.0000	Input voltage at zero	Input voltage from a load cell at zero. Unit : mV/V. This value is determined in zero calibration during the calibration with an actual load.	0.0000		
CAL18 0.0001 to 9.9999	Input voltage at span	Input voltage from a load cell at span. Unit : mV/V. This value and the value of CAL19 are determined in span calibration during the calibration with an actual load.	3.2000		
CAL19 1 to 99999	Calibration weight value correspondin g to Input voltage at span	The calibration weight value corresponding to the Input voltage at span of CAL18 . When performing digital span, CAL17 , CAL18 and CAL19 are required. The decimal point position is the same as the setting of CAL02 .	32000		
CAL26 9.7500 to 9.8500	Gravity acceleration of place of calibration	Gravity acceleration of the place of calibration. Unit : in m/s ² .	9.8000		
CAL27 9.7500 to 9.8500	Gravity acceleration of place of use	Gravity acceleration of the place where the scale is being used. Unit : in m/s ² .	9.8000		
CAL28 0 to 1	Disable averaging hold	0 : Disables. 1 : Enables.	0		

7.6.5. The List Of The Linearization Function

Function No. Parameter and range	Function name	Description	Default value	User setting	MEMO
Lnr01 1 to 5	Number of input points	Number of points where linear input was done. The linear-zero input is included as one point. Digital linearization is not performed when the set value is between 1 and 2.	0		
Lnr02 -7.0000 to 7.0000	Linear-zero	Voltage for linear-zero input. Unit : mV/V.	0.0000		
Lnr03 0 to 99999	Linear 1 Mass value	The mass value for linear 1 input. The decimal point position depends on CAL02 .	0		
Lnr04 0.0000 to 9.9999	Linear 1 Span	The span voltage between linear-zero and linear 1 input. Unit : mV/V.	0.0000		
Lnr05 0 to 99999	Linear 2 Mass value	The mass value for linear 2 input. The decimal point position depends on CAL02 .	0		
Lnr06 0.0000 to 9.9999	Linear 2 Span	The span voltage between linear-zero and linear 2 input. Unit : mV/V.	0.0000		
Lnr07 0 to 99999	Linear 3 Mass value	The mass value for linear 3 input. The decimal point position depends on CAL02 .	0		
Lnr08 0.0000 to 9.9999	Linear 3 Span	The span voltage between linear-zero and linear 3 input. Unit : mV/V.	0.0000		
Lnr09 0 to 99999	Linear 4 Mass value	The mass value for linear 4 input. The decimal point position depends on CAL02 .	0		
Lnr10 0.0000 to 9.9999	Linear 4 Span	The span voltage between linear-zero and linear 4 input. Unit : mV/V.	0.0000		

8. Dimensions

Unit : mm

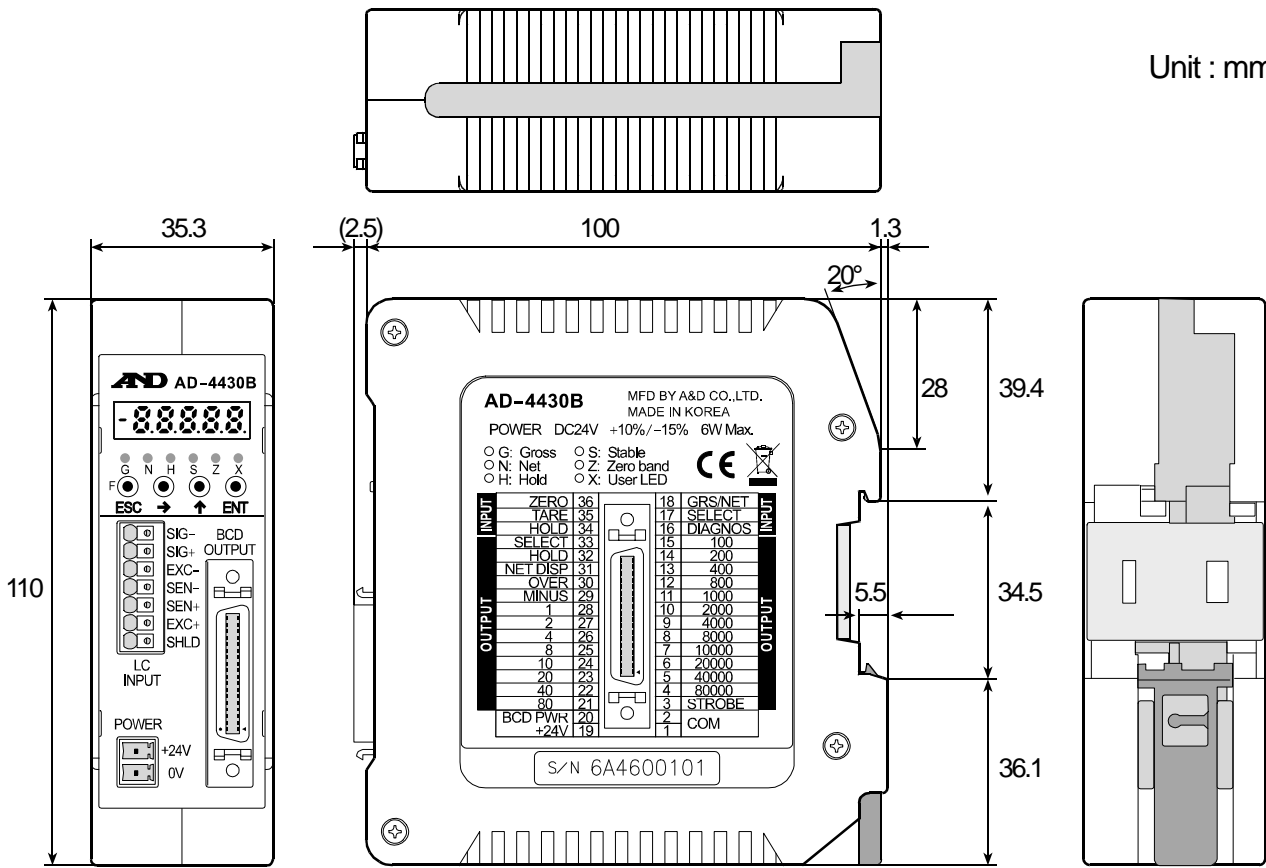



A&D Company, Limited

3-23-14 Higashi-Ikebukuro, Toshima-ku, Tokyo 170-0013, JAPAN

Telephone: [81] (3) 5391-6132

Fax: [81] (3) 5391-6148

A&D ENGINEERING, INC.

1756 Automation Parkway, San Jose, California 95131, U.S.A.

Telephone: [1] (408) 263-5333

Fax: [1] (408) 263-0119

A&D INSTRUMENTS LIMITED

Unit 24/26 Blacklands Way, Abingdon Business Park, Abingdon, Oxfordshire OX14 1DY United Kingdom

Telephone: [44] (1235) 550420

Fax: [44] (1235) 550485

A&D AUSTRALASIA PTY LTD

32 Dew Street, Thebarton, South Australia 5031, AUSTRALIA

Telephone: [61] (8) 8301-8100

Fax: [61] (8) 8352-7409

A&D KOREA Limited

한국에이.엔.디(주)

서울특별시 영등포구 국제금융로6길33 (여의도동) 맨하탄빌딩 817 우편 번호 150-749

(817, Manhattan Bldg., 33. Gukjegeumyung-ro 6-gil, Yeongdeungpo-gu, Seoul, 150-749 Korea)

전화: [82] (2) 780-4101

팩스: [82] (2) 782-4280

ООО A&D RUS

ООО "ЭЙ энд ДИ РУС"

121357, Российская Федерация, г.Москва, ул. Верейская, дом 17

(Business-Center "Vereyskaya Plaza-2" 121357, Russian Federation, Moscow, Vereyskaya Street 17)

тел.: [7] (495) 937-33-44

факс: [7] (495) 937-55-66

A&D INSTRUMENTS INDIA PRIVATE LIMITED

ऐ&डी इन्स्ट्रुमेन्ट्स इण्डिया प्रा० लिमिटेड

509, उद्योग विहार , फेस -5, गुडगांव - 122016, हरियाणा , भारत

(509, Udyog Vihar, Phase-V, Gurgaon - 122 016, Haryana, India)

फोन : 91-124-4715555

फैक्स : 91-124-4715599