

AD-4531B





Digital Indicator

INSTRUCTION MANUAL



WARNING DEFINITIONS

The warnings described in this manual have the following meanings:

 WARNING	A potentially hazardous situation which, if not avoided, could result in death or serious injury.
 CAUTION	A potentially hazardous situation which, if not avoided, may result in minor or moderate injury or damage to the instrument.
	This symbol indicates caution against electrical shock. Do not touch the part where the symbol is placed.
	This symbol indicates the ground terminal.
	This symbol indicates information useful to the user for operation of the device.

© 2014 A&D Company Ltd. All rights reserved.

No part of this publication may be reproduced, transmitted, transcribed, or translated into any language in any form by any means without the written permission of A&D Company Ltd.

The contents of this manual and the specifications of the instrument covered by this manual are subject to change for improvement without notice.

CONTENTS

1. INTRODUCTION	3
1.1. Features	3
2. BEFORE USE	4
2.1. Precautions before use	4
2.2. Precautions during use	4
3. SPECIFICATIONS	6
3.1. General specifications	6
3.2. Functions	7
3.3. Options	8
4. FRONT PANEL	10
4.1. Display	10
4.2. Status indicators	10
4.3. Keys	11
4.4. Operation mode	11
5. REAR PANEL	12
5.1. Connector function	12
5.2. Equivalent circuit diagram of the control input section	14
5.3. Equivalent circuit diagram of the control output section	15
5.4. Attaching the connector	15
5.5. Load cell connection	16
6. COMPONENTS AND FUNCTIONS	18
6.1. Flowchart	18
6.2. Descriptions of functions	19
7. CALIBRATION	20
7.1. Calibration modes	20
7.2. Calibration errors	22
8. FUNCTION MODE	23
8.1. Description of functions	23
8.2. Key operation	23
8.3. Function items	25
9. DIGITAL ZERO (DZ)	30
9.1. Operating by key	30
9.2. Operating by I/O input	30
9.3. Zero tracking	30
9.4. Power on zero	31
9.5. Backup of DZ	31
10. HOLD FUNCTION	32
10.1. Basic function	32

10.2.	Hold indicator	32
10.3.	Priority of hold input	32
10.4.	Values falling out of range during the hold function.....	33
10.5.	Hold modes.....	33
11.	LATCH.....	35
12.	COMPARATOR FUNCTION.....	36
12.1.	Description of the comparator mode	36
12.2.	Setting the upper and lower limit values.....	36
12.3.	Example of the comparator mode	37
12.4.	Hysteresis	38
13.	ANALOG OUTPUT	41
13.1.	Analog voltage DAV (0V to 10V)	41
13.2.	Analog current DAI (4mA to 20mA).....	41
14.	SERIAL INPUT AND OUTPUT	42
14.1.	Data output format	42
14.2.	Command and response.....	42
15.	MAINTENANCE	44
15.1.	Error display.....	44
15.2.	Checking operation	45
16.	SETTING LIST	50
16.1.	Calibration (C function)	50
16.2.	Basic functions.....	51
16.3.	Comparator	52
16.4.	Analog.....	52
16.5.	Serial communication.....	53
16.6.	Unit.....	53
17.	EXTERNAL DIMENSIONS	54

1. INTRODUCTION

Thank you for purchasing the AD-4531B Digital Indicator.

This manual describes how the AD-4531B works and how to get the most out of it in terms of performance. Please read this manual completely before using the AD-4531B.

1.1. Features

The AD-4531B has the following features.

- Calibration without an actual load (Digital span mode)
Keying in the sensor's rated output voltage (mV/V) allows calibration to be performed without using an actual load.
- Digital filter
The selection range of the cutoff frequency is 11 Hz to 0.7 Hz or none.
- Digital zero (DZ, zero adjustment)
The digital zero function sets a desired measurement point as zero and displays the deviation from this zero point. When weighing a load, it can be used as the tare, etc. The zero value is saved in non-volatile memory (EEPROM) and is maintained even if the power is disconnected. Memory backup of 10,000,000 or more times is available.
- Zero tracking function
The zero tracking function updates the zero point automatically by sensing the zero point drift.
- Hold function
Sample, peak, bottom and bipolar peak values can be held using the hold mode.
- Comparator function
Comparison results (HI, OK and LO) are displayed by the LEDs and output as contact signals.
Chattering of the output can be prevented by setting hysteresis.
- Various data output terminals
Available options are comparator output, serial interface (RS-232C/RS-485), analog voltage output (DAV) and analog current output (DAI).

2. BEFORE USE

The digital indicator is a precision instrument. Unpack the digital indicator carefully and confirm that all items are present.

2.1. Precautions before use

- Avoid water and moisture.
- Avoid vibration, shock, extremely high temperature and humidity, direct sunlight, dust and air containing salt or sulfurous gases.
- Avoid places where inflammable gases or vapors are present.
- The operating temperature range is -10°C to $+40^{\circ}\text{C}$.
- A 100 VAC to 240 VAC power source is required. Use a stable power supply free from sudden dropout or noise as they can cause malfunctions. Avoid sharing the power line.
- Keep cables away from power cables and other sources of electrical noise.
- Connect only a non-inductive load of $10\text{ k}\Omega$ or more to the analog voltage output terminals.
- Connect only a non-inductive load of $510\ \Omega$ or less to the analog current output terminals.
- When connecting long cables to the sensors, keep the cables away from power cables and other sources of electrical noise.
- Do not connect the AD-4531B to the power supply before installation is completed. The AD-4531B has no switch to disconnect the power supply.
- Use shielded load cell cables.
- Do not connect too many sensors. Otherwise, instrument damage may occur.

2.2. Precautions during use

- The AD-4531B is a precision instrument that measures the microvolt output from sensors. Prevent noise sources such as power lines, radios, electric welders or motors from affecting the instrument.
- Do not try to modify the AD-4531B.
- In all hold modes, the hold data is saved digitally, so there is no drooping of the value displayed on the display panel or the analog output. Note that the hold function is disabled when the AD-4531B is disconnected from the power supply.

 WARNING

Disconnect from the power supply before removing the cover.

- When removing the cover, make sure that the power is disconnected.



Do not touch the instrument immediately after it is disconnected from the power supply.

- To avoid electrical shock, do not touch the internal part of the instrument within ten seconds after disconnecting from the power supply.

 CAUTION

Be sure to fasten all the screws completely.

- Loose screws may come off during operation and a short circuit may occur or measurement errors may occur due to noise.

3. SPECIFICATIONS

3.1. General specifications

- Number of measurement points 1
- Sensor type Strain gauge sensors (Output resistance: 10k Ω or less)
- Voltage requirement 100 VAC to 240 VAC (50/60 Hz)
- Power requirement Approx. 10 VA
- Sensor power supply 5 VDC \pm 5%, 50 mA
120 Ω sensor: Up to one sensor can be connected.
350 Ω sensor: Up to three sensors can be connected.
- Measurement ranges Signal input range: -35 to +35 mV (-7 to +7 mV/V)
Zero adjustment range: -35 to +35 mV (-7 to +7 mV/V)
Minimum guaranteed input sensitivity: 0.15 μ V/d or more (d = minimum division)
Minimum displayed input sensitivity: Non-limit
- A/D conversion method Delta sigma method
- Internal division Approx. 16,000,000 counts
- Sampling rate 100 times / second
- Display range -999999 to +999999
- Linearity Within 0.005%F.S. \pm 1 digit
- Temperature characteristics Zero: \pm 0.1 μ V/ $^{\circ}$ C typ.
Span: \pm 8 ppm/ $^{\circ}$ C typ.
- Operating temperature -10 $^{\circ}$ C to +40 $^{\circ}$ C
- Operating humidity Max. 85% RH (no condensation)
- Calibration method Digital span: Method not using an actual load
Actual load calibration
- External dimensions 96 x 48 x 127.5 mm (W x H x D)
Panel cutout: 92 x 45 mm
Spacing: Width: 120 mm or more
Length: 70 mm or more
- Weight Approx. 290 g
- Display panel Measured value display:
7-segment, 6-digit red LED screen with 9.2-mm character size
Polarity display: 1 red LED screen
Status displays:
1 red LED screen, 2 green LED screens, 2 orange LED screens
Key switch: 5 switches

3.2. Functions

- Digital zero (Zero adjustment)
 - Sets the measured value to zero using the ZERO key, external input or the command signal.
 - The zero value is saved in non-volatile memory (EEPROM).
 - Available setting range
 - The available setting range is 1 to 100% of the rated capacity.
- Zero tracking function
 - Automatically updates the zero point by sensing the zero point drift.
 - Available setting range
 - Tracking time :0.0 to 5.0 (second)
 - Tracking width :0.0 to 9.9 (d)
- Power on zero function
 - Sets the zero state at power on.
- Digital filter function
 - Cutoff frequency range: 0.7 to 11 (Hz)
- Comparator function
 - HI, OK or LO is determined by setting the upper or lower limit value.
- Hold function
 - Select from sample hold, peak hold, bottom hold, or bipolar peak hold.
- Latch function
 - Perform latching of the displayed value, comparator output, analog output, serial output, using the external LATCH input.
- Relay output function (option)
 - Provides contact output of the HI, OK or LO signals.
- Serial input and output function (option)
 - The RS-232C/RS-485 option can output measured values and input commands.
- Analog output function (option)
 - Outputs the measured value as an analog voltage or current.

3.3. Options

3.3.1. Options

AD-4530-200:	Relay output
AD-4530-030:	RS-485
AD-4530-040:	RS-232C
AD-4530-007:	Analog output
AD-4530-237:	Relay output, RS-485, Analog output
AD-4530-247:	Relay output, RS-232C, Analog output

Note: Only one option can be installed in the AD-4531B at a time.

3.3.2. Option specifications

- Relay output
HI, OK, LO

AD4530-200	250 VAC or 30 VDC 3A (Total current 5A)
AD4530-237	Contact construction: Metallic contact
AD4530-247	Contact capability: 1a

Mechanical operating life: 5,000,000 times or more
Electrical operating life: 100,000 times or more (Resistive load)
Connector: 4-pin (HI, OK, LO, COM)

- RS-485
Conforms to EIA RS-485

AD4530-030	Number of drops: Up to 31
AD4530-237	Connector: 5-pin (A, B, SG, A, B)

- RS-232C
Conforms to EIA RS-232C

AD4530-040	Connector: 5-pin (RxD, TxD, SG, IC, IC)
AD4530-247	

- Analog output
D/A conversion method: PWM

AD4530-007	Resolution: Equivalent to 13 bits
AD4530-237	Response rate: Approx. 500 ms
AD4530-247	Voltage output: 0-10V Adaptive load: 10 kΩ min.

Current output: 4-20 mA Adaptive load: 510 Ω max.
Non-linearity: ±0.1% typ.
Temperature coefficient: Zero point 100 ppm/°C typ.
Connector: 3-pin (VOUT, IOUT, COM)

3.3.3. Installing an option

1. Remove the two screws that secure the guide rail, and then remove the guide rail.
2. Remove the two screws that secure the case.
3. Pull the case out from the front panel (holding it as shown).
4. Remove unnecessary blank panels with nippers, etc.
5. Insert the option board at the position specified on the rear of the front panel.
6. Reattach the case and guide rail by reversing the steps above.

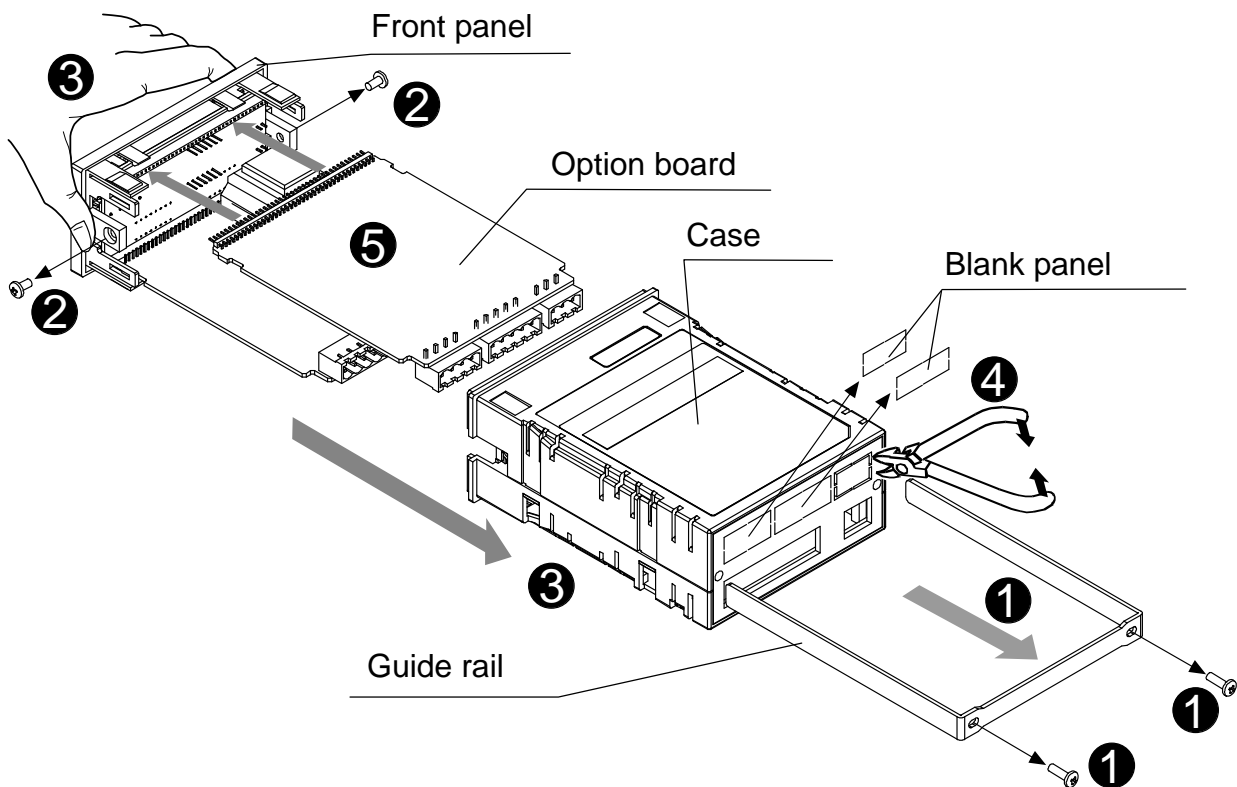

4. FRONT PANEL

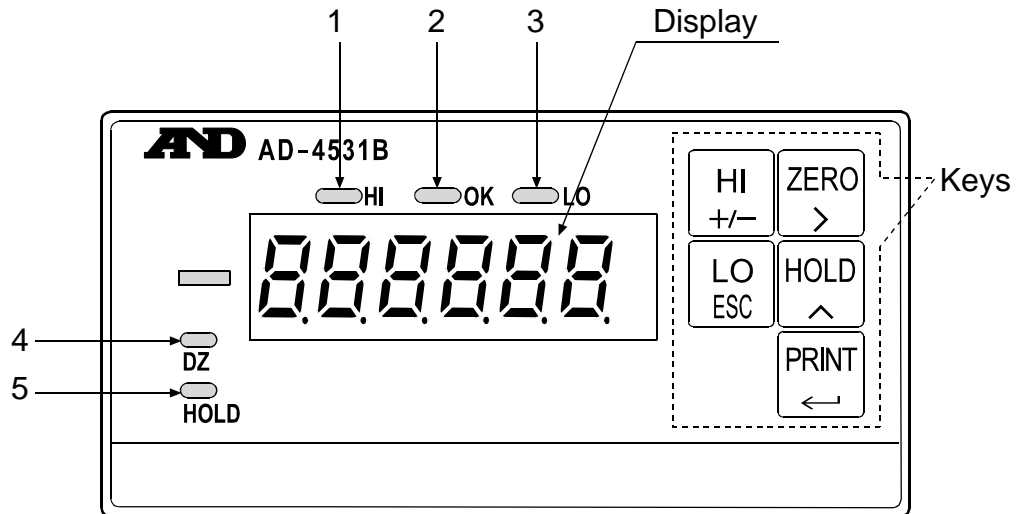







4.1. Display

Displays a measured or set value. To set the decimal point position, use the function mode ([F-D]). The display is composed of six seven-segment LEDs plus a minus sign.

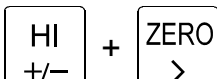

4.2. Status indicators

	Name	Description
1	HI	Turns on when the measured value is greater than the upper limit (HI).
2	OK	Turns on when the measured value is equal to or greater than the lower limit and equal to or less than the upper limit.
3	LO	Turns on when the measured value is less than the lower limit (LO).
4	DZ	Turns on when adjusting the zero value. (Digital zero)
5	HOLD	Turns on when a value is being held.

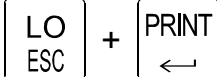
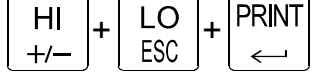
4.3. Keys

Operation	Function
	Press to proceed to the upper limit value setting mode. When inputting a numerical value, press to change the polarity.
	Press to proceed to the lower limit value setting mode. When inputting a numerical value, press to cancel the setting.
	Press to turn the digital zero function on. When inputting a numerical value, press to shift the position of the blinking digit to the right or change the function group.
	Press to turn the digital zero function off.
	Press to turn the hold function on or off. When inputting a numerical value, press to change the blinking digit or change the function parameter.
	Press to output the serial data (print). When inputting a numerical value, press to enter the setting.
	Press to proceed to the calibration mode.
	Press to proceed to the function selection mode.
	Press to proceed to the selection mode in the check mode.

- * The digital zero function sets a desired measurement point as zero and displays the deviation from this zero point. When weighing a load, it can be used as the tare, etc.
- * The zero value is saved in non-volatile memory (EEPROM) and is maintained even if the power is disconnected.
- * To change the zero adjustment operation, use the function (EF-11).

To protect against accidental operation, press the  +  keys or press and hold the  key for more than 1 second to turn the digital zero function on.

4.4. Operation mode

- Upper / lower limit setting mode
Use this mode to set the upper and lower limit values of the comparator.
- Calibration mode
Use this mode to perform zero and span calibration with an actual load (calibration weight).
- Function mode
Use this mode for setting functions.
- Check mode
Use this mode to confirm input and output operation.

5. REAR PANEL

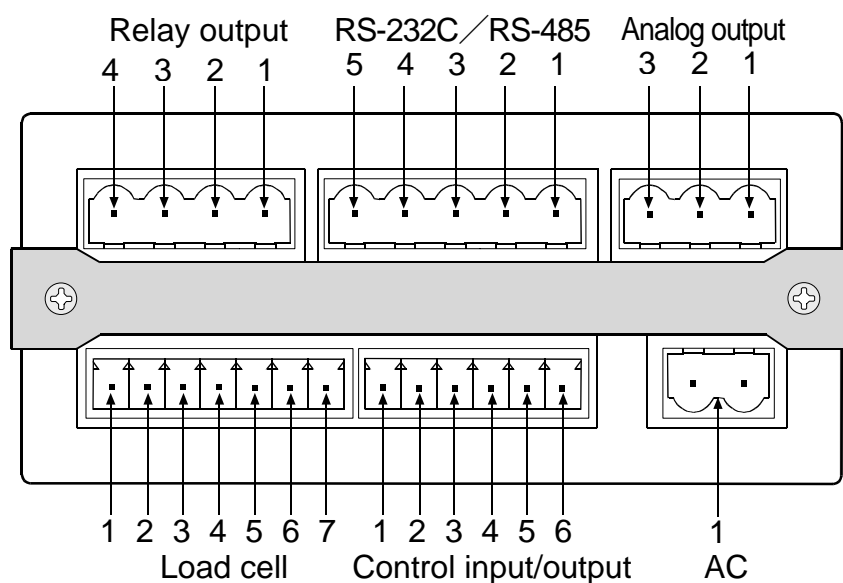

⚠ CAUTION

Confirm the terminal numbers when making connections.

- When making connections, confirm the terminal numbers printed on the top of the indicator case.

5.1. Connector function

5.1.1 AC input connector

(1) AC Connect the AC power cord.

The power requirement is 100 VAC to 240 VAC, 50/60 Hz.

⚠ CAUTION

When making connections,

- Switch off the power of all the instruments used.
- Keep cables away from power cables and other sources of electrical noise.

5.1.2 Load cell connector

(1) SHLD Connect the shielded cable of the sensor cable.

(2) SIG- Negative signal input terminal for the sensors

(3) SIG+ Positive signal input terminal for the sensors

(4) EXC- Negative excitation terminal for the sensors

(5) SEN- Negative sensing input terminal for the sensors

When performing the 4-wire connection, connect terminals 4 and 5 (EXC- and SEN-).

- (6) SEN+ Positive sensing input terminal for the sensors
When performing the 4-wire connection, connect terminals 7 and 6 (EXC+ and SEN+).
- (7) EXC+ Positive excitation terminal for the sensors

5.1.3 Control input/output connector

- (1) EXT IN 1 Control input terminal 1
- (2) EXT IN 2 Control input terminal 2
- (3) IN COM Control input common terminal
- (4) EXT OUT 1 Control output terminal 1
- (5) EXT OUT 2 Control output terminal 2
- (6) OUT COM Control output common terminal

5.1.4 Relay output connector (Option)

- (1) COM Relay output common terminal
- (2) LO Relay LO output terminal
Outputs LO when the measured value is less than the lower limit.
- (3) OK Relay OK output terminal
Outputs OK when the measured value is equal to or greater than the lower limit and equal to or less than the upper limit.
- (4) HI Relay HI output terminal
Outputs HI when the measured value is greater than the upper limit.

 CAUTION
<p>Comparator output</p> <ul style="list-style-type: none"> ■ To prevent damage, do not exceed the rated capacities of the output relays. To protect the output relays, use a varistor, CR circuits or diodes.

5.1.5 Serial communication connector (Option)

In the case of RS-232C:

- (1) IC Internally connected (Do not use)
- (2) IC Internally connected (Do not use)
- (3) SG Signal ground terminal
- (4) TxD Sending terminal
- (5) RxD Receiving terminal

In the case of RS-485 (2-wire connection):

- (1) B B terminal
- (2) A A terminal
- (3) SG Signal ground terminal
- (4) B B terminal
- (5) A A terminal

* Each of the A and B connections has two terminals.

These terminals are connected internally and can be used for a terminating resistor or multi-drop connection.

5.1.6 Analog output connector (Option)

- (1) COM Common terminal of the analog output
- (2) IOUT Analog current output terminal
- (3) VOUT Analog voltage output terminal

5.2. Equivalent circuit diagram of the control input section

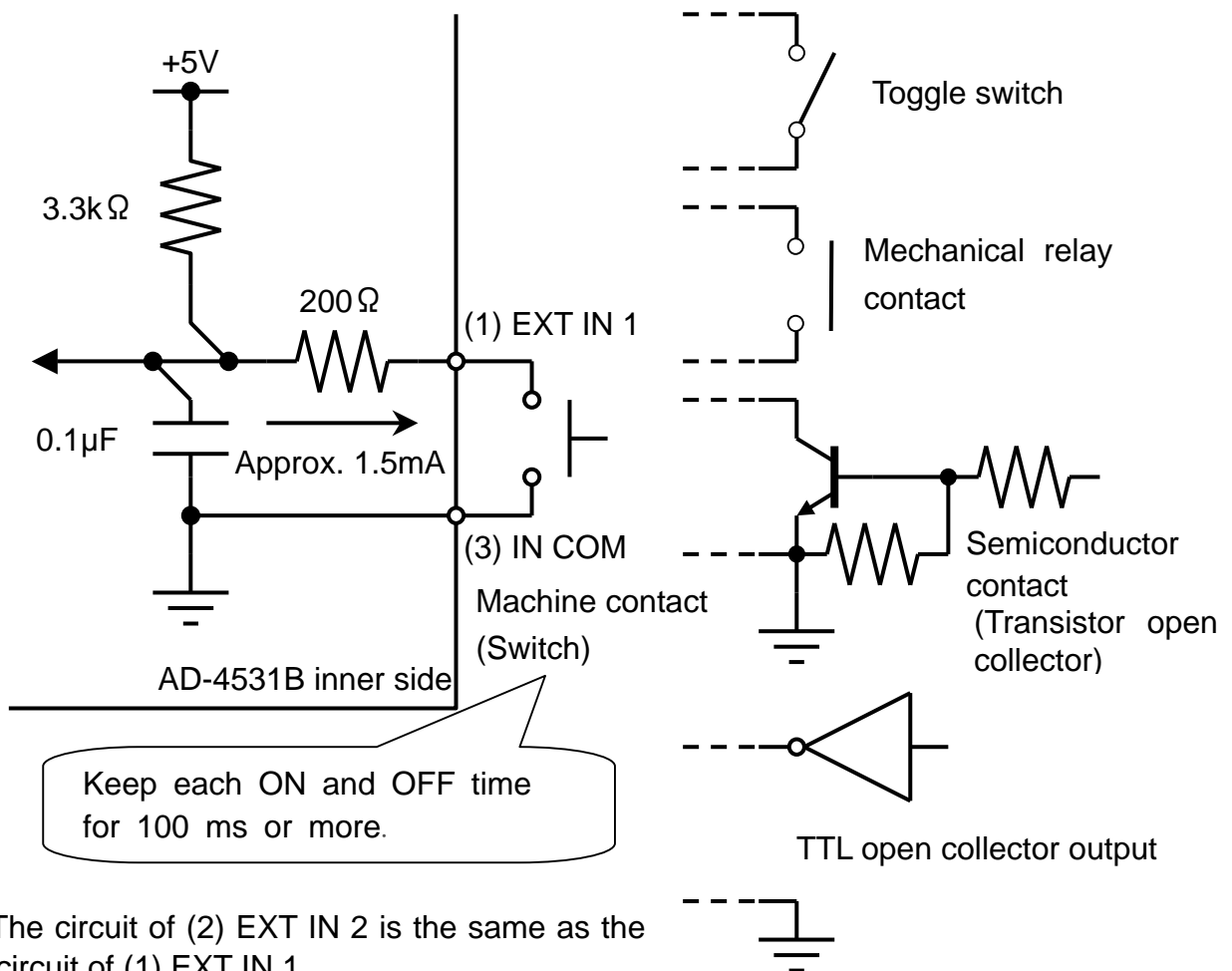

* The circuit of (2) EXT IN 2 is the same as the circuit of (1) EXT IN 1.

⚠ CAUTION

When connecting the input terminal:

- Select a switching element of the non-voltage input type, such as a mechanical contact or semiconductor contact.
- Use the leakage of the switching element, when OFF, of 30 μA or less

5.3. Equivalent circuit diagram of the control output section

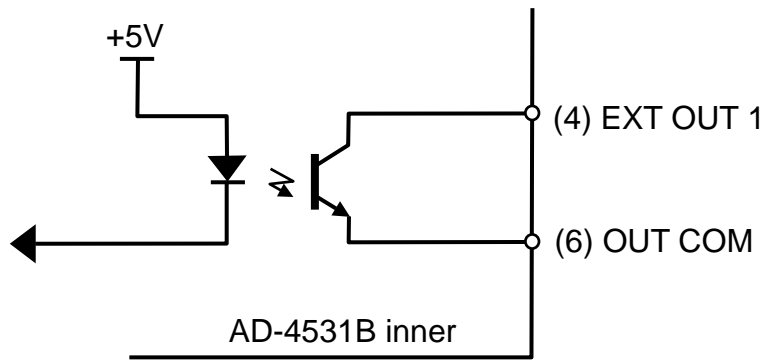

* The circuit of (5) EXT OUT 2 is the same as the circuit of (4) EXT OUT 1.

Output circuit	Open collector output
Output voltage	40 VDC
Output drive current	50 mA
Output saturation voltage	1.5 V

5.4. Attaching the connector

AC input and options connectors

Pitch: 5.08 mm
 Wire size: 12 to 24 (AWG)
 Stripping length: 6 to 7 mm
 Tightening torque: 0.5 to 0.6 Nm

Load cell and control input/output connectors

Pitch: 3.50 mm
 Wire size: 16 to 28 (AWG)
 Stripping length: 6 to 7 mm
 Tightening torque: 0.2 Nm

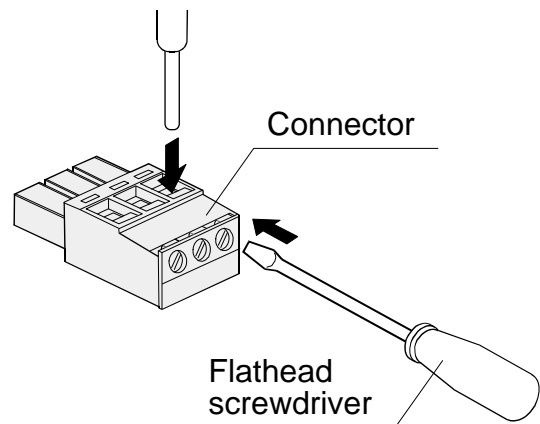
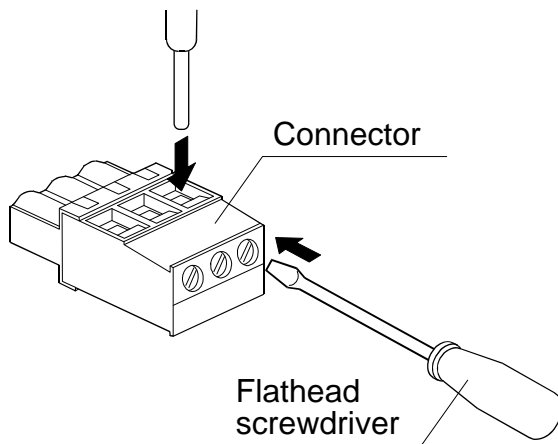

5.5. Load cell connection

Two types of load cell connection are available: 6-wire connection and 4-wire connection.

For high precision and stable measurement, 6-wire connection is recommended.

□ 6-wire connection

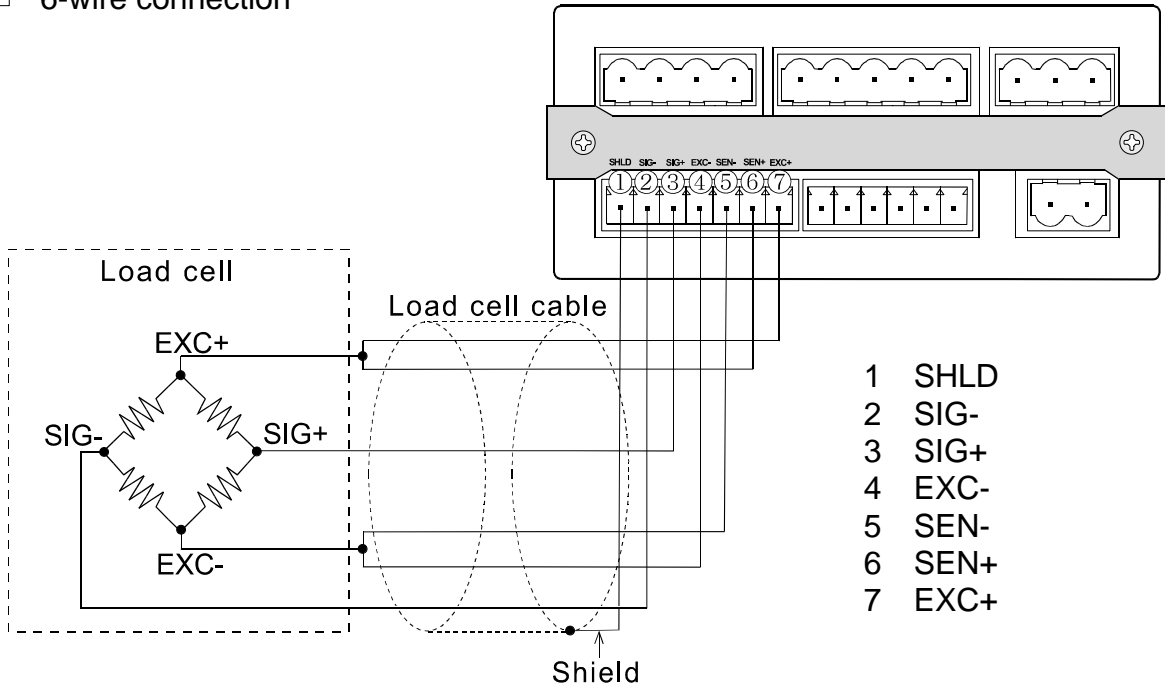

□ 4-wire connection

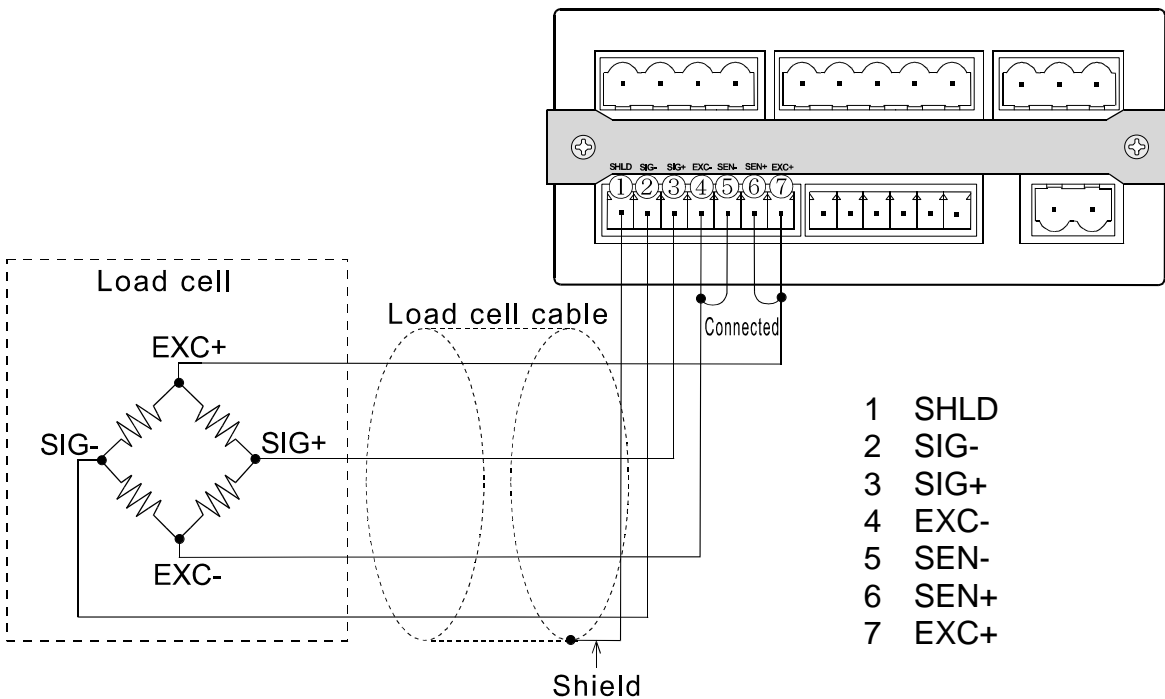

Type	Advantages	Disadvantages	Description
6-wire connection (recommended)	The error is small even when the load cell cable is extended, a thin load cell cable is used, or multiple load cells are used.	Complicated wiring	Use a 6-wire shielded cable when a summing box is used.
4-wire connection	Simple wiring	The influence of the load cell cable resistance worsens the temperature coefficient. Prone to the influence of the contact resistance of the connector	The error increases when the load cell cable is extended or multiple load cells are used.

Precautions on performing the 4-wire connection

- ❑ Be sure to connect terminals 7 and 6 (EXC+ and SEN+) and terminals 5 and 4 (SEN- and EXC-).
- ❑ If the cable needs extending, use a cable with as large a cross-sectional area as possible or keep the cable as short as possible.

6. COMPONENTS AND FUNCTIONS

The following flowchart shows how the functions of the AD-4531B are executed.

6.1. Flowchart

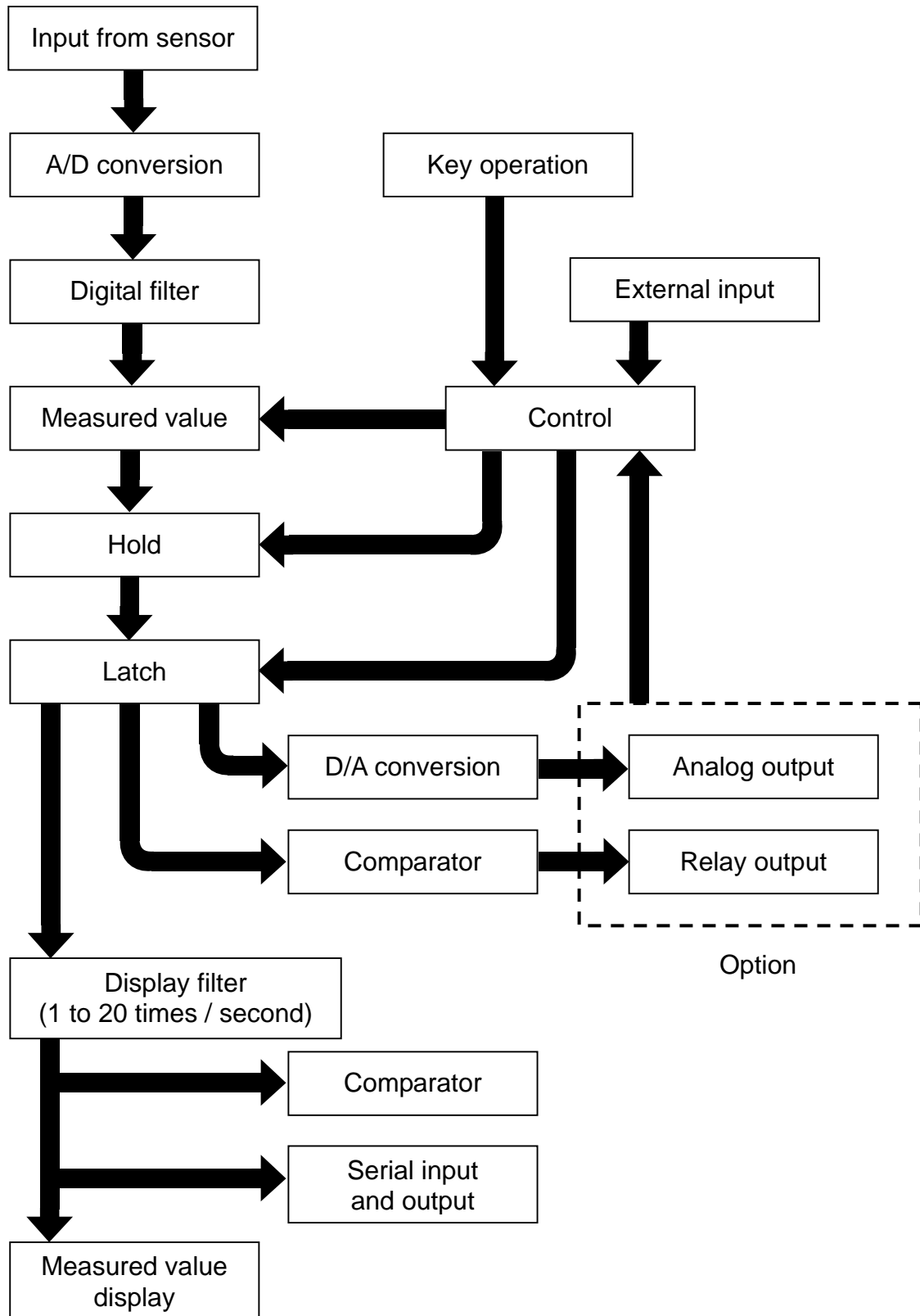

6.2. Descriptions of functions

6.2.1. Digital filter

The selection range of the cutoff frequency is 11 Hz to 0.7 Hz or none.

6.2.2. Digital zero

The digital zero function sets a desired measurement point as zero and displays the deviation from this zero point.

6.2.3. Hold function

The AD-4531B has four hold modes: sample hold, peak hold, bottom hold and bipolar peak hold. Select a hold mode in the function mode (*F0-04*).

6.2.4. Latch function

The AD-4531B can latch the displayed and output values specified by the function (*F0-05*), by the ON/OFF timing of the external LATCH input.

The latch operation occurs after processing the hold operation.

6.2.5. Comparator function

The comparator function compares the measured value against the limit values, displays the comparison results with LEDs and outputs the comparison results (HI, OK or LO) from the rear panel relay output terminals.

6.2.6. Relay output (Option)

The results of the comparison can be output by the relay output terminal.

6.2.7. Analog output (Option)

The analog output outputs data by converting the measured value to an analog voltage DAV (0 V to 10 V) or analog current DAI (4 mA to 20 mA). (*F2-01* to *F2-04*)

6.2.8. Serial input and output (Option)

By using the RS-232C or RS-485, outputting the measured value, receiving commands and setting functions are available.

7. CALIBRATION

The AD-4531B measures voltage signals from sensors and displays the values. Calibration is performed so that the AD-4531B performs correctly.

The decimal point (CF-01), minimum division (CF-02) and rated capacity (CF-03) are set using the function mode.

The zero point input voltage (CF-04), the span input voltage (CF-05) and the displayed value for the span input voltage (CF-06) are adjusted using the calibration mode.

Calibration setting by the function mode is also available. (Digital span)

- * During calibration, maintain a stable environment to prevent calibration errors.
- * When the measured value is stable, the **HOLD** LED is turned on.
- * The decimal point blinks to indicate that the current value is not a measured value.

7.1. Calibration modes

In the measurement mode, press the **HI +/-** + **PRINT ←** keys to enter the calibration mode.

PRINT ← Enter the zero point calibration mode.

LO ESC Return to the measurement mode.

7.1.1. Zero point calibration mode

With nothing on the load cell, wait for the **HOLD** LED to turn on and press the **PRINT ←** key.

PRINT ← Perform zero point calibration and proceed to the span calibration mode.

LO ESC Cancel zero point calibration and proceed to the span calibration mode.



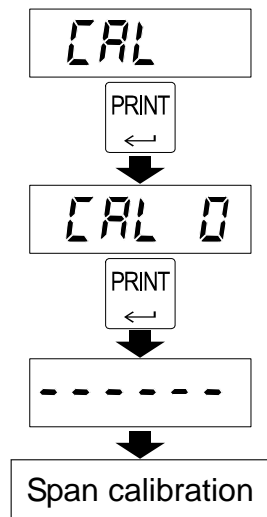

HI +/- Hold down to display the mV/V value of the zero point.



7.1.2. Span calibration mode

Input the value to be displayed when the actual load for span calibration is applied to the load cell.

Wait for the **HOLD** LED to turn on and press the **PRINT** key.

-  Select the digit to be changed.
-  Increase the value of the digit to be changed.
-  Change the polarity.
-  Perform span calibration and proceed to the storing mode.
-  Cancel span calibration and proceed to the storing mode.

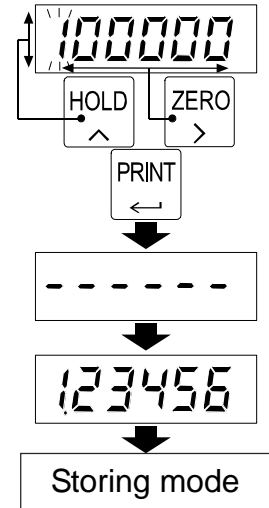



* After span calibration, the AD-4531B displays the mV/V value of span calibration for 3 seconds, and then proceeds to the storing mode.

7.1.3. Storing mode

Save the calibration zero, span and displayed value acquired.

When calibration is not performed, data is not saved.

-  Save the data acquired and return to the measurement mode.
-  Do not save the data acquired and return to the measurement mode.

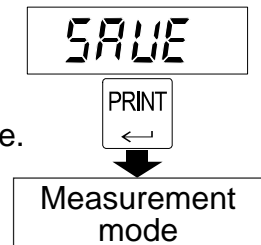

7.2. Calibration errors

Display	Cause	Remedy
<i>C E2</i>	Voltage at zero point calibration exceeds in the positive direction.	Confirm the rating and connection of the load cell.
<i>C E3</i>	Voltage at zero point calibration exceeds in the negative direction.	
<i>C E4</i>	The value of the calibration weight exceeds the rated capacity.	Use a proper calibration weight.
<i>C E5</i>	The value of the calibration weight is less than the minimum division.	
<i>C E6</i>	The load cell sensitivity is insufficient.	Confirm the load cell connection. Use a proper calibration weight.
<i>C E7</i>	Voltage at span calibration is less than voltage at the zero point.	Confirm the load cell connection.
<i>C E8</i>	The load cell output voltage is too high when loaded to capacity.	Use a load cell with a greater rated capacity or set a smaller rated capacity value.

8. FUNCTION MODE

Use the function mode to set various functions. The set values are saved in non-volatile memory and are maintained even if the power is disconnected.

8.1. Description of functions

The first 2 digits of the Function No. are the function group. The last 2 digits of the Function No. are the function item.

CF Calibration function

F0 Basic function

F1 Comparator function

Use this function to set the comparator operation.

F2 Analog output function

Use this function to set the output values of the analog voltage output and analog current output.

F3,F4 Serial communication function



Use this function to set the RS-232C or RS-485.

* Set the zero point input voltage (*CF-04*), the span input voltage (*CF-05*) and the displayed value for the span input voltage (*CF-06*) in the calibration mode.

* Set the upper limit value (*F1-01*) and lower limit value (*F1-02*) in the comparator mode.

* When setting a function, the decimal point blinks to indicate the current value is not a measured value.

8.2. Key operation

In the measurement mode, press the  +  keys to enter the function selection mode.

8.2.1. Function selection mode



Select the function group. (First 2 digits)



Select the function item. (Last 2 digits)



Enter the setting changing mode.



Save the setting in non-volatile memory and then return to the measurement mode.

8.2.2. Setting changing mode (Two methods)

P Parameter selection method (All digits blinking)



Change the parameter.



Enter the setting and return to the function selection mode.



Cancel the setting and return to the function selection mode.

D Digital input method (Change the blinking digit only)



Move the digit to be changed to the right.



Change the value of the blinking digit.



Change the polarity.









Enter the setting and return to the function selection mode.



Cancel the setting and return to the function selection mode.

8.3. Function items

8.3.1. Calibration (C function)

Function No. Setting range	Function	Description	Default value Setting type
<i>CF-01</i> 0 to 5	Decimal point position	Decimal point position of the measured value: <i>0:000000 3:000,000</i> <i>1:00000.0 4:000,000</i> <i>2:000000 5:000000</i>	<i>0</i> P
<i>CF-02</i> 1 to 50	Minimum division	Minimum division (d) of the measured value. <i>1:1 5:5 20:20</i> <i>2:2 10:10 50:50</i>	<i>1</i> P
<i>CF-03</i> 1 to 999999	Rated capacity	Measurement is possible up to the value of this setting plus 8 d (8 minimum divisions). Decimal point position depends on <i>CF-01</i> .	<i>70000</i> D
<i>CF-04</i> -7.00000 to 7.00000	Input voltage of zero point	Input voltage from the load cell at zero point. (Unit: mV/V)	<i>0.00000</i> D
<i>CF-05</i> 0.00001 to 9.99999	Input voltage of span	Input voltage from the load cell at span (measurement point - zero point). (Unit: mV/V)	<i>3.20000</i> D
<i>CF-06</i> -999999 to 999999	Displayed value for input voltage of span	Displayed value for span (measurement point - zero point). Decimal point position depends on <i>CF-01</i> .	<i>32000</i> D
<i>CF-07</i> 0 to 100	Zero adjustment range	Range to enable zero adjustment by the ZERO key. Expressed as a percentage of the rated capacity with the calibration zero point as the center.	<i>100</i> D
<i>CF-08</i> 0.0 to 5.0	Zero tracking time	Performed in combination with zero tracking width. (Unit: second) When <i>0.0</i> , zero tracking is not performed.	<i>0.0</i> D
<i>CF-09</i> 0.0 to 9.9	Zero tracking width	Performed in combination with zero tracking time. (Unit: d) When <i>0.0</i> , zero tracking is not performed.	<i>0.0</i> D
<i>CF-10</i> 0 to 2	Power on zero	Digital zero when the power is connected: <i>0</i> : Digital zero function off <i>1</i> : Perform digital zero <i>2</i> : Use state when the power is disconnected.	<i>0</i> P
<i>CF-11</i> 1 to 3	Zero operation	<i>1</i> : On with  <i>2</i> : On with  +  <i>3</i> : On by pressing and holding  for more than 1 second * In all settings: When it is on, off with  + 	<i>1</i> P
<i>CF-12</i> 1 to 2	Zero of the I/O input	<i>1</i> : On / Off depends on the I/O input. <i>2</i> : Only digital zero on (no off)	<i>1</i> P

8.3.2. Basic function

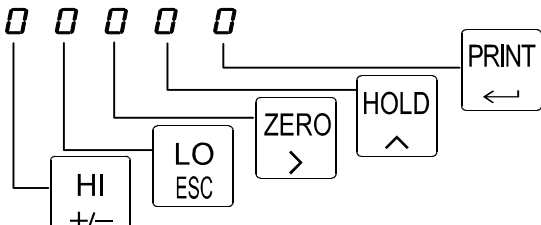
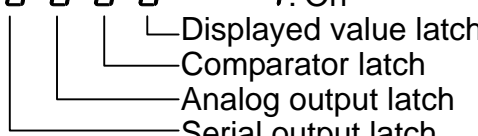
Function No. Setting range	Function	Description	Default value Setting type
FD-01 00000 to 11111	Disable key	Each digit of the setting corresponds to a key switch. Only available in the measurement mode. Key assignment: 0 : Enabled 1 : Disabled 	00000 (Binary) D
FD-02 0 to 9	Digital filter	Cutoff frequency: 0 : Off 1 : 11 Hz 2 : 8 Hz 3 : 5.6 Hz 4 : 4 Hz 5 : 2.8 Hz 6 : 2 Hz 7 : 1.4 Hz 8 : 1 Hz 9 : 0.7 Hz	8 P
FD-03 1 to 20	Display update rate	1 : 1 time/second 2 : 2 times/second 5 : 5 times/second 10 : 10 times/second 20 : 20 times/second	20 P
FD-04 0 to 4	Hold mode	0 : Off 1 : Sample hold 2 : Peak hold 3 : Bottom hold 4 : Bipolar peak hold	1 P
FD-05 0.0 to 9.9	Hold averaging time	Set by the unit of 0.1 second. When 0.0 , averaging is not performed.	0.0 D
FD-06 0000 to 1111	LATCH function	Function corresponds to an external input latch. Setting and latch Assignment: 0 : Off 1 : On 	0000 (Binary) D
FD-07 0 to 6	External input 1	0 : Off 1 : DZ key 2 : Hold 3 : Print 4 : Start hold 5 : Stop hold 6 : Latch	1 P
FD-08 0 to 6	External input 2		2 P
FD-09 0 to 9	External output 1	0 : Off 1 : DZ key 2 : Holding 3 : Hold busy 4 : Hi 5 : OK 6 : Lo 7 : Measuring (ON) 8 : Measuring (1 Hz) 9 : Measuring (50 Hz)	1 P
FD-10 0 to 9	External output 2		2 P

* To confirm the measured value when setting the digital filter (**FD-02**), press the  key.

When the measured value is displayed, the  LED blinks and the display can be

set to zero by pressing the  key.

Press the  key to return the setting display.

8.3.3. Comparator

Function No. Setting range	Function	Description	Default value Setting type
F1-01 -999999 to 999999	Upper limit value	Upper limit value of comparator. Decimal point position depends on CF-01 .	0 D
F1-02 -999999 to 999999	Lower limit value	Lower limit value of comparator. Decimal point position depends on CF-01 .	0 D
F1-03 0 to 2	Comparator mode	0 : No comparison 1 : Comparison, excluding the zero band 2 : Comparison, including the zero band	2 P
F1-04 -999999 to 999999	Zero band	Set the zero band for the comparator mode.	0 D
F1-05 1 to 3	Hysteresis mode	Hysteresis direction: 1 : Upward 2-level judgment 2 : Upper / lower limit judgment 3 : Downward 2-level judgment	2 P
F1-06 0.0 to 5.0	Hysteresis time	Set the hysteresis time by the unit of 0.1 second. When 00 , the hysteresis mode is not used.	00 D
F1-07 00 to 99	Hysteresis width	Set the hysteresis width by the unit of d. When 00 , the hysteresis mode is not used.	99 D

8.3.4. Analog

Function No. Setting range	Function	Description	Default value Setting type
F2-01 -999999 to 999999	0 V output	Measured value at DAV 0V output. Decimal point position depends on CF-01 .	0 D
F2-02 -999999 to 999999	10 V output	Measured value at DAV 10V output. Decimal point position depends on CF-01 .	10000 D
F2-03 -999999 to 999999	4 mA output	Measured value at DAI 4 mA output. Decimal point position depends on CF-01 .	0 D
F2-04 -999999 to 999999	20 mA output	Measured value at DAI 20 mA output. Decimal point position depends on CF-01 .	10000 D

8.3.5. Serial communication

Function No. Setting range	Function	Description	Default value Setting type
<i>F3-01</i> 2400 to 38400	Baud rate	<i>2400</i> : 2400 bps <i>4800</i> : 4800 bps <i>9600</i> : 9600 bps <i>19200</i> : 19200 bps <i>38400</i> : 38400 bps	<i>2400</i> P
<i>F3-02</i> 7 to 8	Data bit length	<i>7</i> : 7 bits <i>8</i> : 8 bits	<i>7</i> P
<i>F3-03</i> 0 to 2	Parity	<i>0</i> : None <i>1</i> : Odd <i>2</i> : Even	<i>2</i> P
<i>F3-04</i> 1 to 2	Stop bit	<i>1</i> : 1 bit <i>2</i> : 2 bits	<i>1</i> P
<i>F3-05</i> 1 to 2	Terminator	<i>1</i> : CRLF ASCII code: CR: 0D, LF: 0A <i>2</i> : CR	<i>1</i> P
<i>F3-06</i> 1 to 6	Output mode	<i>1</i> : Stream mode <i>2</i> : Manual print mode <i>3</i> : Auto print mode (Outputs data once when the measured value exceeds the zero band and is stabilized for the first time.) <i>4</i> : Auto print mode (Outputs data each time the measured value exceeds the zero band and is stabilized.) <i>5</i> : Command mode <i>6</i> : Jet stream mode (Outputs data at each sampling, depending on the baud rate.)	<i>2</i> P
<i>F3-07</i> 00 to 99	Instrument No.	ID that is added to the serial output. When <i>00</i> , the ID is not added.	<i>00</i> D

8.3.6. Unit

Function No. Setting range	Function	Description	Default value Setting type
<i>F4-00</i> 0 to 4	Unit	<i>0</i> : Specify the unit character (<i>F4-01</i> to <i>F4-05</i>) <i>1</i> : kg <i>3</i> : t <i>2</i> : g <i>4</i> : lb	<i>1</i> P
<i>F4-01</i> <i>F4-02</i> <i>F4-03</i> <i>F4-04</i> <i>F4-05</i> 00 to 7F	Unit character1 Unit character2 Unit character3 Unit character4 Unit character5	Unit character added to the serial output. Set using the hexadecimal ASCII code. <i>00</i> : none	<i>00</i> (Hexadecimal) D

8.3.7. Errors

Display	Cause	Remedy
<i>Rd E</i>	The data can not be acquired from A/D converter.	Repair is required.
<i>EEPE</i>	Correct data cannot be read from EEPROM.	Perform initialization. If the initialization does not clear the error, repair is required.
<i>CALE</i>	Calibration data error.	Perform calibration.
<i>dt E</i>	A set value is out of range.	Check set values and correct if necessary.

8.3.8. ASCII code (20h~7Fh)

Hexadecimal	00	01	02	03	04	05	06	07	08	09	0A	0B	0C	0D	0E	0F
20	SP	!	"	#	\$	%	&	'	()	*	+	,	-	.	/
30	0	1	2	3	4	5	6	7	8	9	:	;	<	=	>	?
40	@	A	B	C	D	E	F	G	H	I	J	K	L	M	N	O
50	P	Q	R	S	T	U	V	W	X	Y	Z	[\]	^	_
60	`	a	b	c	d	e	f	g	h	i	j	k	l	m	n	o
70	p	q	r	s	t	u	v	w	x	y	z	{	 	}	~	DL

20 SP is space 7F DL is DEL

9. DIGITAL ZERO (DZ)

The digital zero function sets a desired measurement point as zero and displays the deviation from this zero point. When weighing a load, it can be used as the tare, etc.

While this function is used, the **DZ** LED turns on.

9.1. Operating by key

When the **ZERO** key is pressed, the display is set to zero and the DZ function is turned on.

If you want to turn the DZ function off, press the **HI +/-** + **ZERO** keys.

* The operating procedure can be changed in the function mode (CF-11).

Press the **HI +/-** + **ZERO** keys or press and hold the **ZERO** key for more than 1 second, turn on the DZ function.

When it is turned on, the display is set to zero.

9.2. Operating by I/O input

Whether the DZ function is ON or OFF depends on the operation of the zero terminal of the I/O input.

When the zero terminal is on (connected to the COM terminal), the DZ function is turned on and the display is set to zero.

You can disable the digital zero off in the function mode (CF-12).

9.3. Zero tracking

Using the zero tracking function, the AD-4531B updates the zero point automatically by sensing the zero point drift.

Zero tracking is available only when the digital zero function is turned on. Set the zero tracking time (CF-08) and zero tracking width (CF-09) in the function mode.

* When the zero point is beyond the zero adjustment range, zero tracking is not performed.

* The zero point updated using the zero tracking function will not be saved in non-volatile memory.

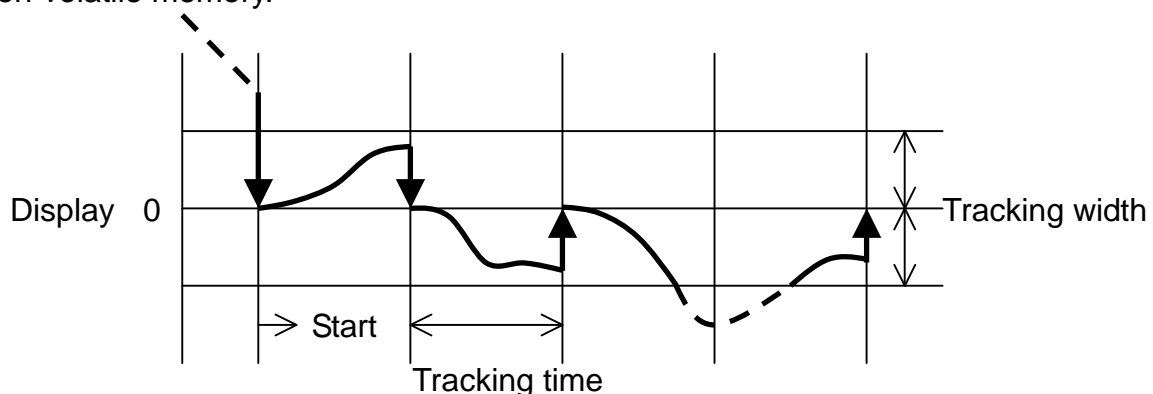

9.4. Power on zero

Select the zero adjustment operation when the power is connected. ($[F-10]$)

0: Digital zero function off

Measurement is based on the zero point of the calibration.

Use for measuring an absolute value such as force measurement.

1: Perform digital zero

Measurement is based on the zero point when the power is connected.

Use for weighing a load.

2: Use the state when the power is disconnected.

Measurement is based on the DZ.

Use for measurements that require a long time such as a hopper scale.

It is a useful function in case of a power failure.

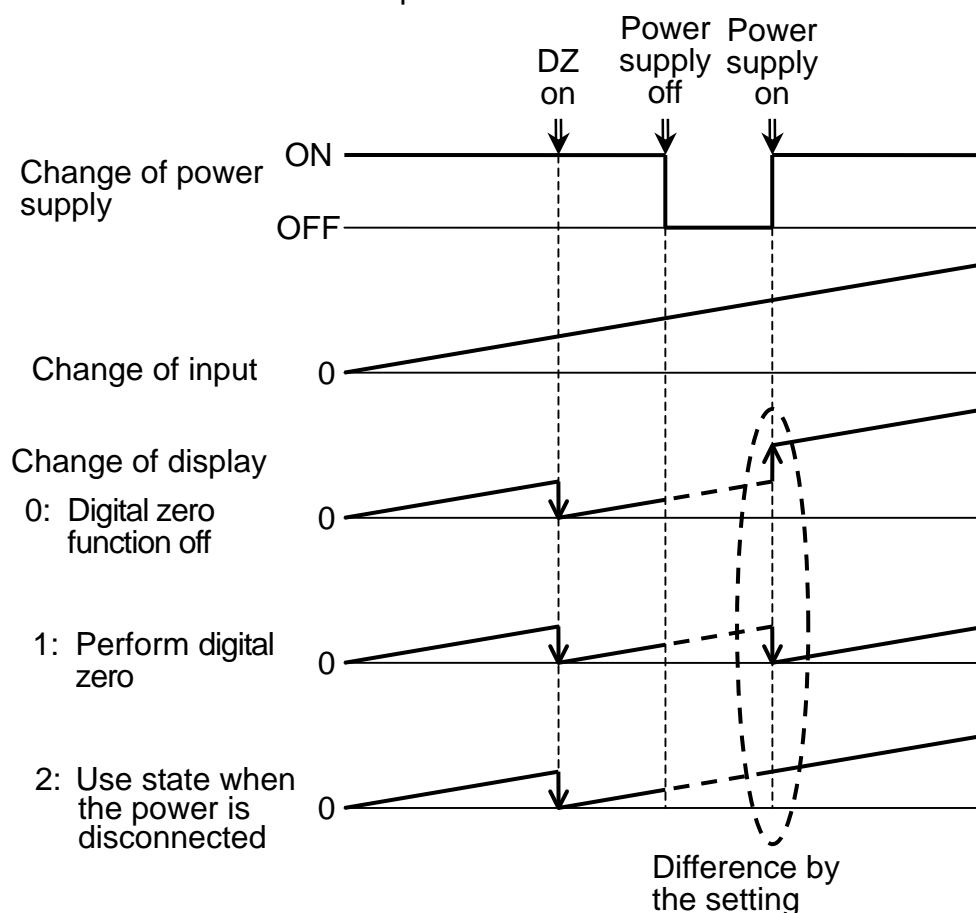

9.5. Backup of DZ

The DZ value is saved in non-volatile memory (EEPROM).

Writing up to 10,000,000 times is available, so keep track of use frequency.

If the available DZ memory is 10% or less, the DZ LED blinks.

With the setting ($[F-10]=2$), the backup memory is updated only when the DZ value is updated by key operation or command.

(The zero point updated using the zero tracking function will not be saved in non-volatile memory.)

10. HOLD FUNCTION

The AD-4531B has four hold modes: sample hold, peak hold, bottom hold and bipolar peak hold. Select a hold mode in the function mode (F0-04).

- In all hold modes, the hold data is saved digitally, so there is no drooping of the value displayed on the display panel or the analog output. Note that the hold function is disabled when the AD-4531B is disconnected from the power supply.

10.1. Basic function

Start the hold function by using the  key, the hold terminal of the external input, or a serial communication command.

10.1.1. Operation by using the key

Press the  key. The hold function starts and the AD-4531B holds the displayed value.

While the display is in the hold mode, pressing the  key again cancels the hold function and the AD-4531B displays the measured value.

10.1.2. Operation using the external input hold terminal

When the external hold input terminal is turned on (contact input), the hold function starts.

To hold the displayed value at this time, keep the external input hold terminal in the on state.

To cancel the hold function, set the external input hold terminal to the off state.

10.1.3. Operation using a serial communication command

The hold function is started by the hold ON command "H_{R F}^{C L}" of the serial communication and is canceled by the hold OFF command "C_{R F}^{C L}".

10.2. Hold indicator

The AD-4531B indicates that it is in the hold state by turning the  LED on.

10.3. Priority of hold input

To start the hold function, setting the external input hold terminal has a higher priority than other operations.

10.4. Values falling out of range during the hold function

If the value exceeds the specified range during the hold function, the display becomes blank.

Note that functions such as the comparator or output are processed based on the hold data.

10.5. Hold modes

10.5.1. Sample hold mode

Holds the display and output when receiving a hold input.

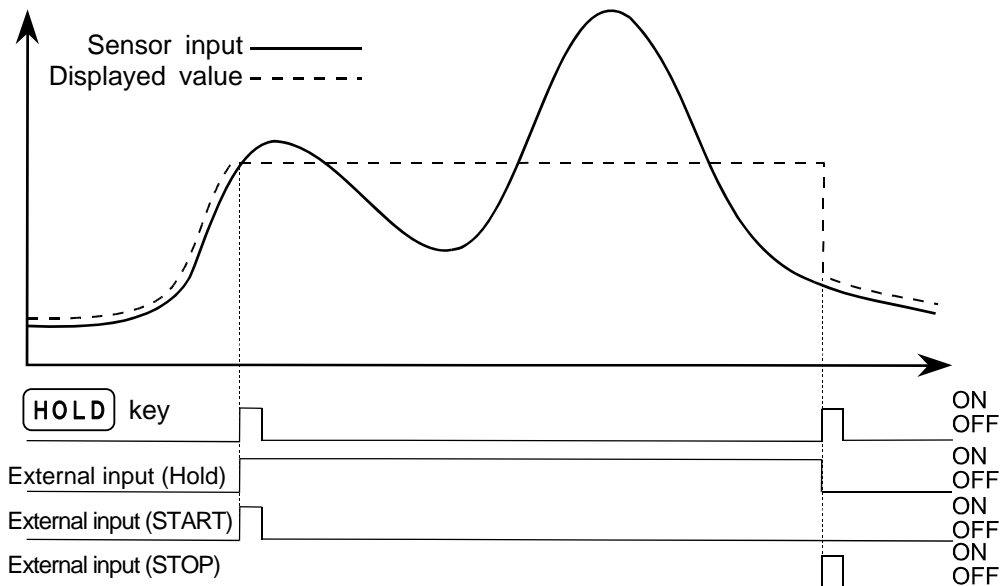

When the hold averaging time is specified, holds the value averaged during the specified duration. The averaging time is only valid for the sample hold mode.

10.5.2. Peak hold mode

Holds the peak value when receiving a hold input.

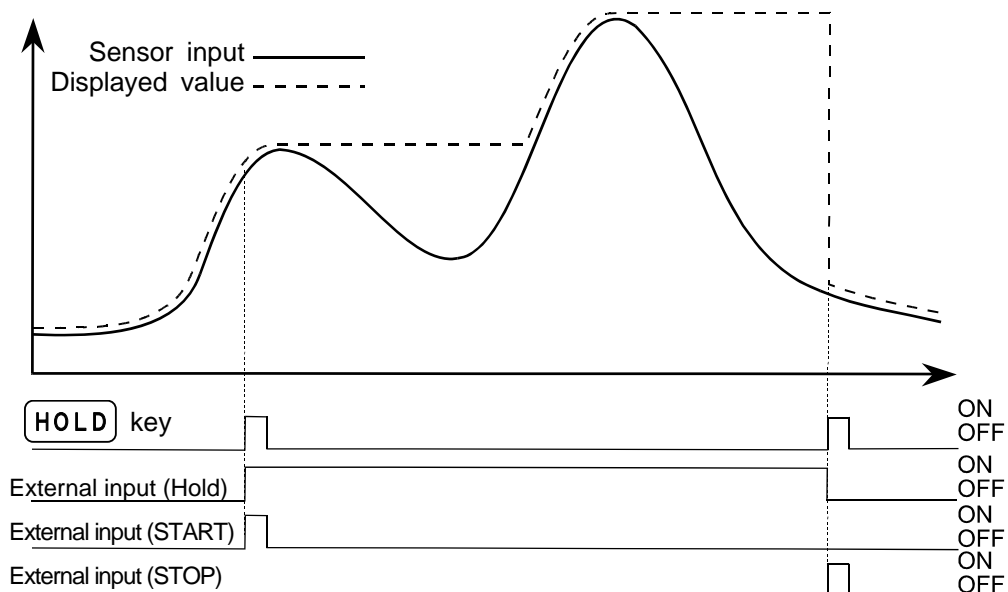

10.5.3. Bottom hold mode

Holds the bottom value when receiving a hold input.

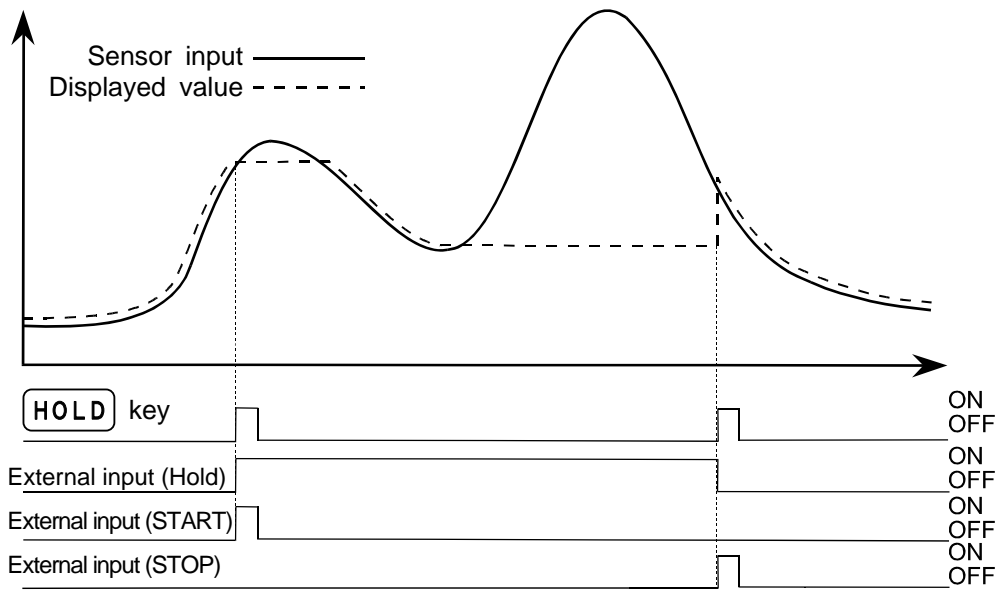

10.5.4. Bipolar peak hold mode

Holds the absolute peak value when receiving a hold input.

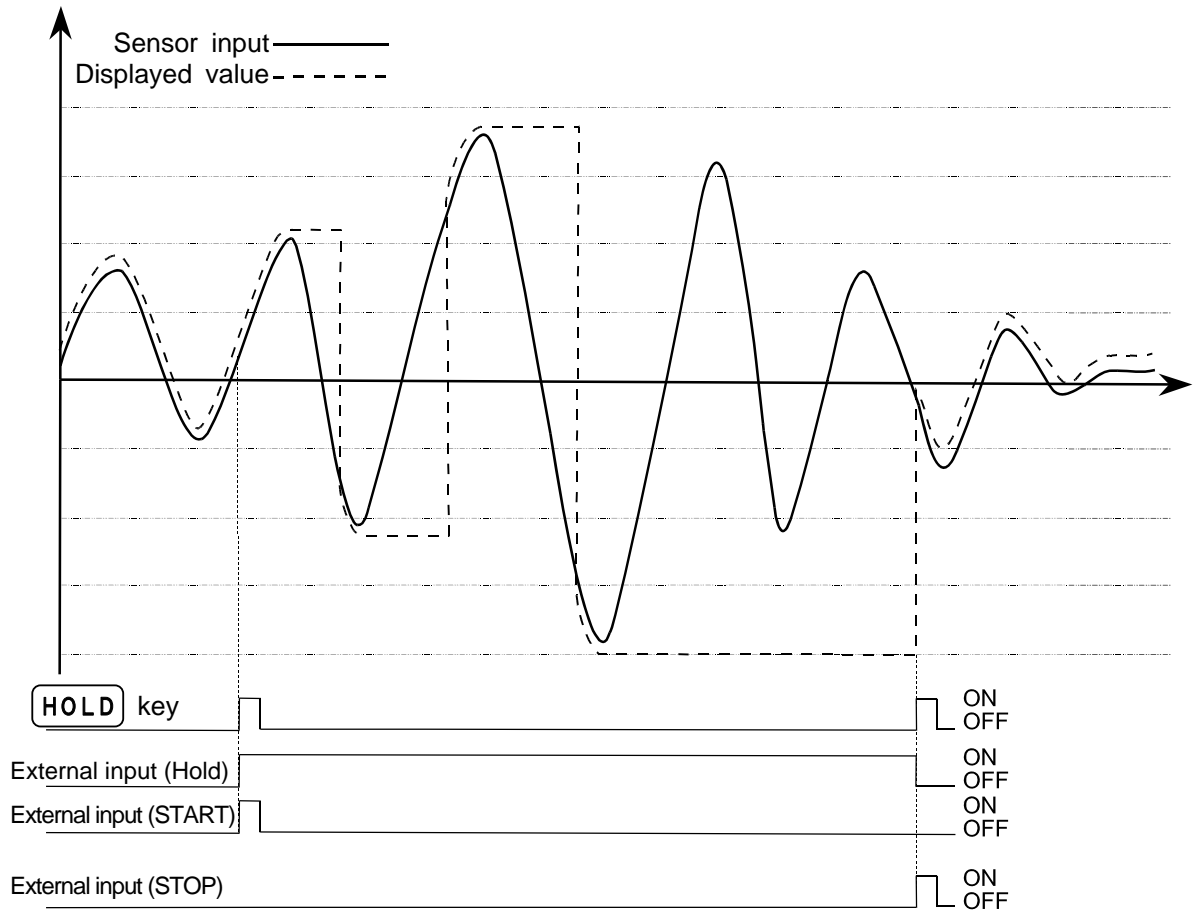

11. LATCH

The AD-4531B can latch the displayed and output values specified by the function (F0-05) in response to the external LATCH input.

The latch operation occurs after processing the hold operation.

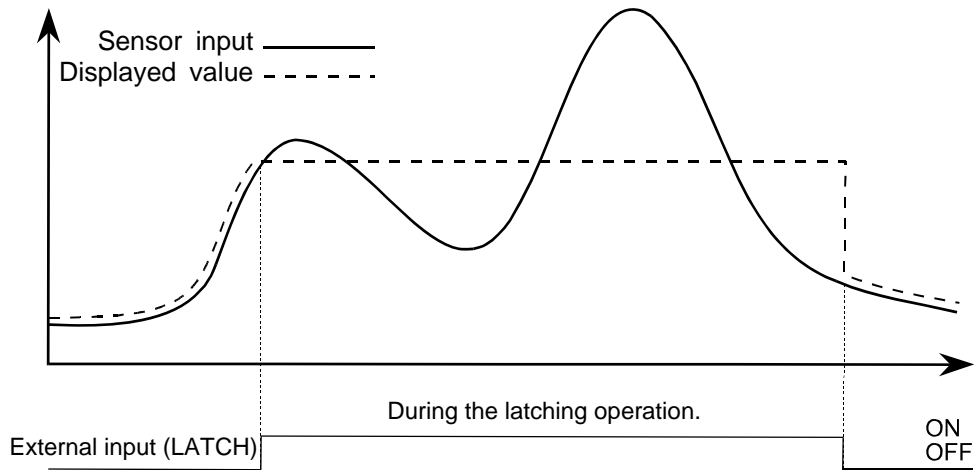

12. COMPARATOR FUNCTION

The comparator function compares the measured value against the set values and the results are displayed by the LEDs. If the relay option is installed, it outputs the comparison results (HI, OK or LO) from the rear panel relay output terminals.

12.1. Description of the comparator mode

- The relation between the comparator outputs and the upper and lower limit values is as shown below:

Comparison result	Comparison condition
HI	Upper limit < Measured value
OK	Lower limit ≤ Measured value ≤ Upper limit
LO	Measured value < Lower limit

- * HI is output when the measured value exceeds the specified range in the positive direction. LO is output when the measured value exceeds the specified range in the negative direction.
- Upper limit and lower limit values can be negative.
For example, if the upper limit value is -1000 and the lower limit value is -2000, HI is output for the measured value of -500 and LO is output for the measured value of -2500.
- Make sure that the upper limit value is greater than the lower limit value.

12.2. Setting the upper and lower limit values

Set the upper limit value (F I-01) and lower limit value (F I-02) as follows:

In the measurement mode, press the HI
+/- or LO
ESC key to enter the setting mode for the upper or lower limit value.

In the upper or lower limit value setting mode, the AD-4531B blinks the HI or LO LED. (The relay output is not affected.)

The set value is displayed. Set the value by operating the key.

- ZERO
> Shift the blinking digit to the value to be changed.
- HOLD
^ Change the value of the blinking digit.
- HI
+/- Change the polarity.
- PRINT
← Save the setting and return to the measurement mode.
- LO
ESC Cancel the setting and return to the measurement mode.

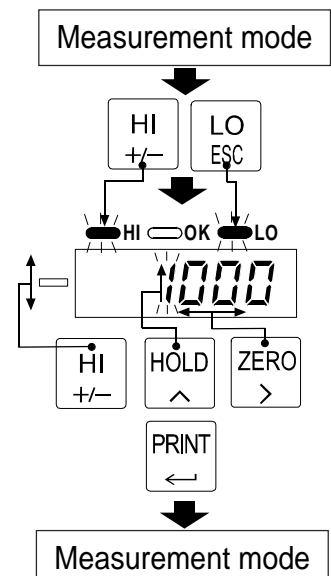

- * If a key is not pressed within 20 seconds in the upper or lower limit setting mode, the AD-4531B will cancel the setting and return to the measurement mode.
- * The decimal point blinks to indicate that the current value is not a measured value.

12.3. Example of the comparator mode

Continuous comparison excluding the zero band

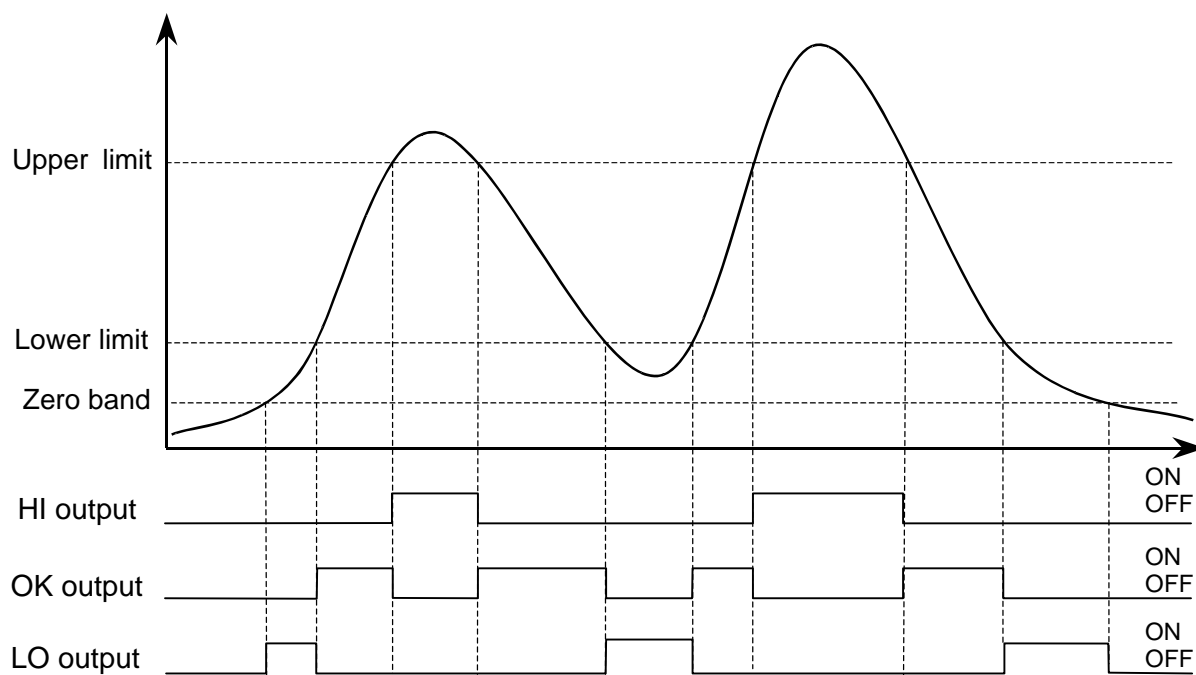

12.4. Hysteresis

A hysteresis width and time is provided for the output relay on/off timing to prevent the output terminals from chattering.

When the measured value exceeds the set value, the relay is turned on. If the measured value falls below the set value and it is further reduced by the hysteresis width, or if the hysteresis time has elapsed, the relay is turned off.

The hysteresis mode, time and width can be set in the function modes (*F 1-05* to *F 1-07*).

12.4.1. Hysteresis upward 2-level judgment (*F 1-05=1*)

□ Relation between HI and OK

When the measured value exceeds the upper limit value, HI is output immediately. Even if the measured value falls below the upper limit value, OK is not output immediately. OK will be output when the measured value falls below the hysteresis width, or when the hysteresis time has elapsed.

□ Relation between LO and OK

When the measured value exceeds the lower limit value, OK is output immediately. Even if the measured value falls below the lower limit value, LO is not output immediately. LO will be output when the measured value falls below the hysteresis width, or when the hysteresis time has elapsed.

Judgment example

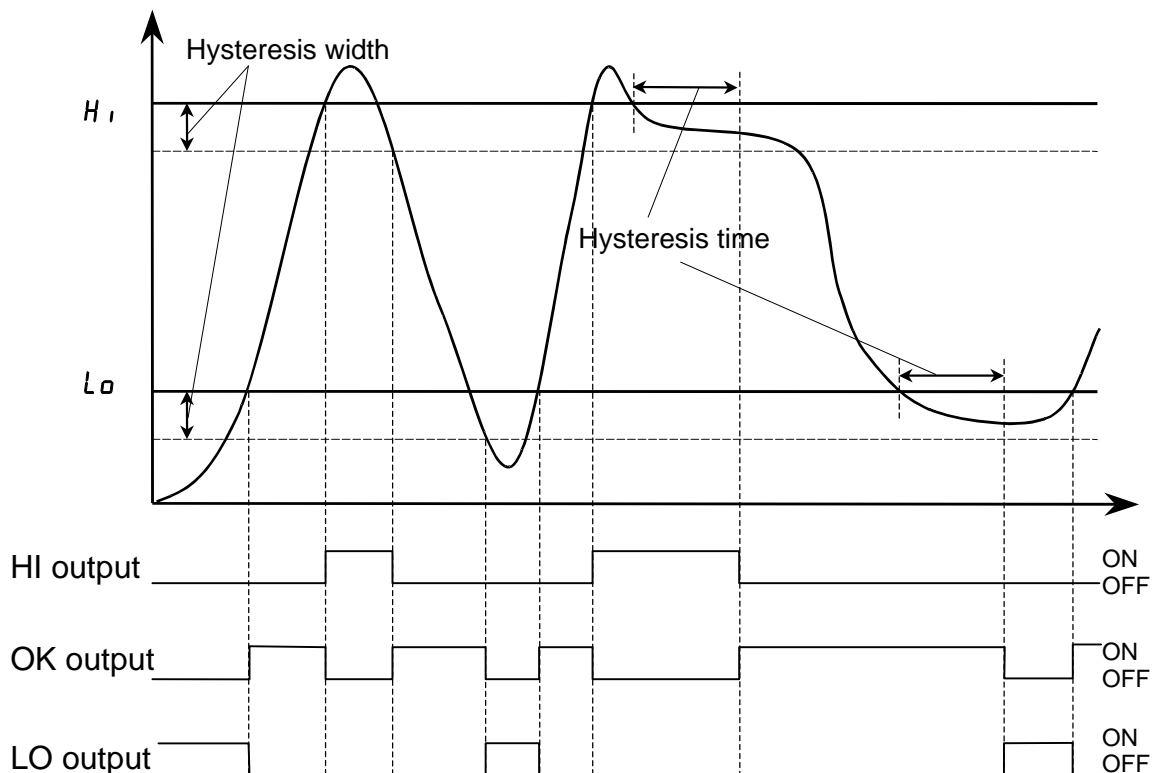

12.4.2. Hysteresis upper/lower limit judgment (F 1-05=2)

□ Relation between HI and OK

When the measured value exceeds the upper limit value, HI is output immediately. Even if the measured value falls below the upper limit value, OK is not output immediately. OK will be output when the measured value falls below the hysteresis width, or when the hysteresis time has elapsed

□ Relation between LO and OK

When the measured value falls below the lower limit value, LO is output immediately. Even if the measured value exceeds the lower limit value, OK is not output immediately. OK will be output when the measured value exceeds the hysteresis width, or when the hysteresis time has elapsed.

Judgment example

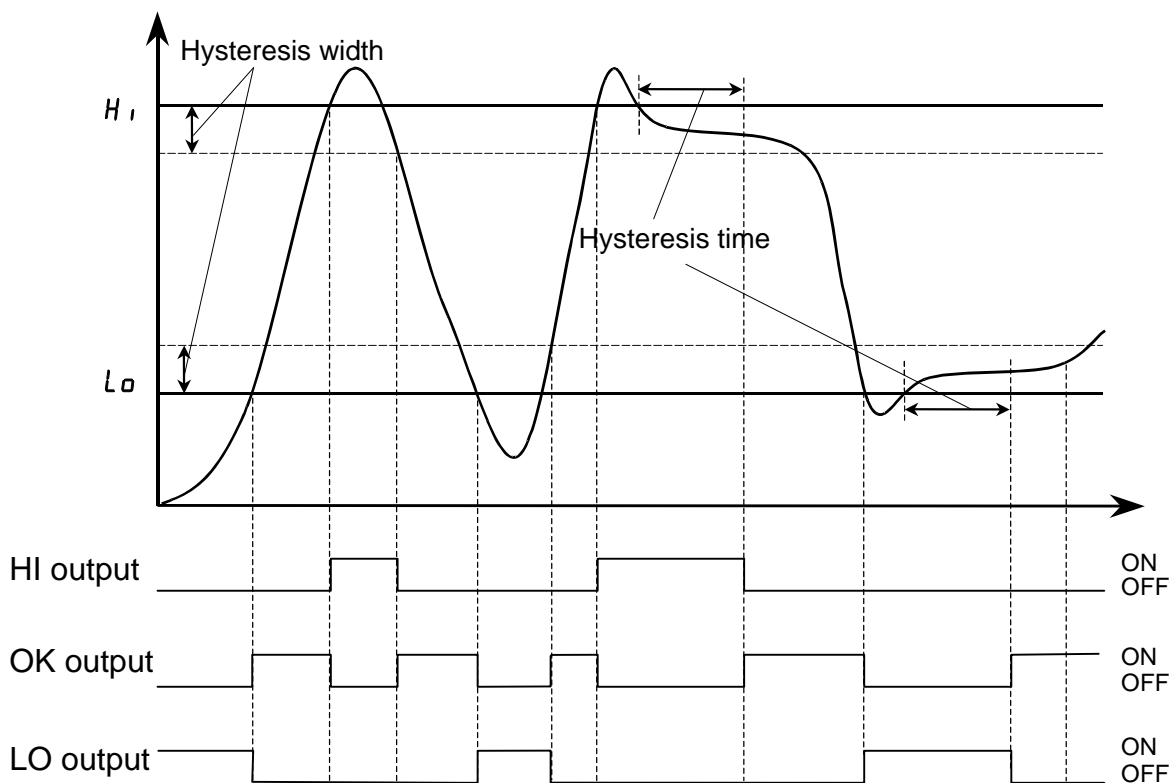

12.4.3. Hysteresis downward 2-level judgment (F 1-05=3)

□ Relation between HI and OK

When the measured value falls below the upper limit value, OK is output immediately.

Even if the measured value exceeds the upper limit value, HI is not output immediately. HI will be output when the measured value exceeds the hysteresis width, or when the hysteresis time has elapsed.

□ Relation between LO and OK

When the measured value falls below the lower limit value, LO is output immediately.

Even if the measured value exceeds the lower limit value, OK is not output immediately. OK will be output when the measured value exceeds the hysteresis width, or when the hysteresis time has elapsed.

Judgment example

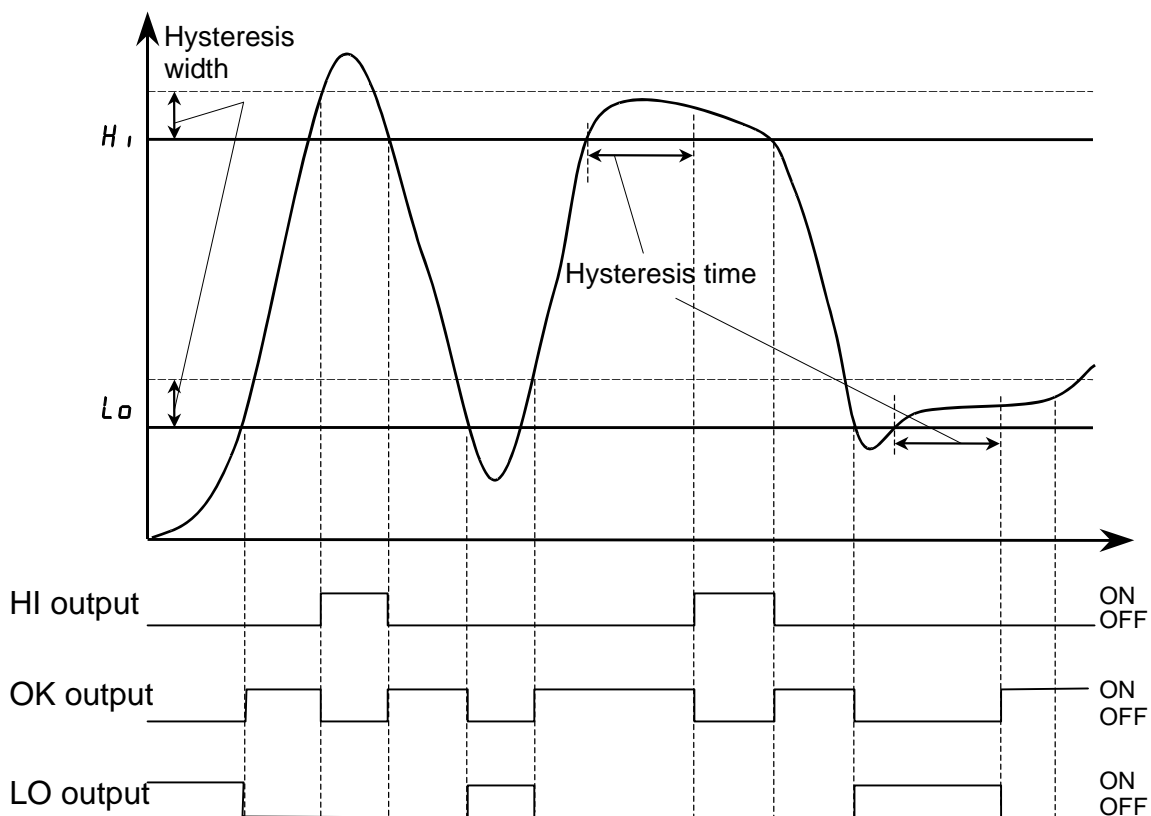

13. ANALOG OUTPUT

The analog output outputs data by converting the measured value to an analog voltage DAV (0V to 10V) or an analog current DAI (4mA to 20mA). (F2-01 to F2-04)

13.1. Analog voltage DAV (0V to 10V)

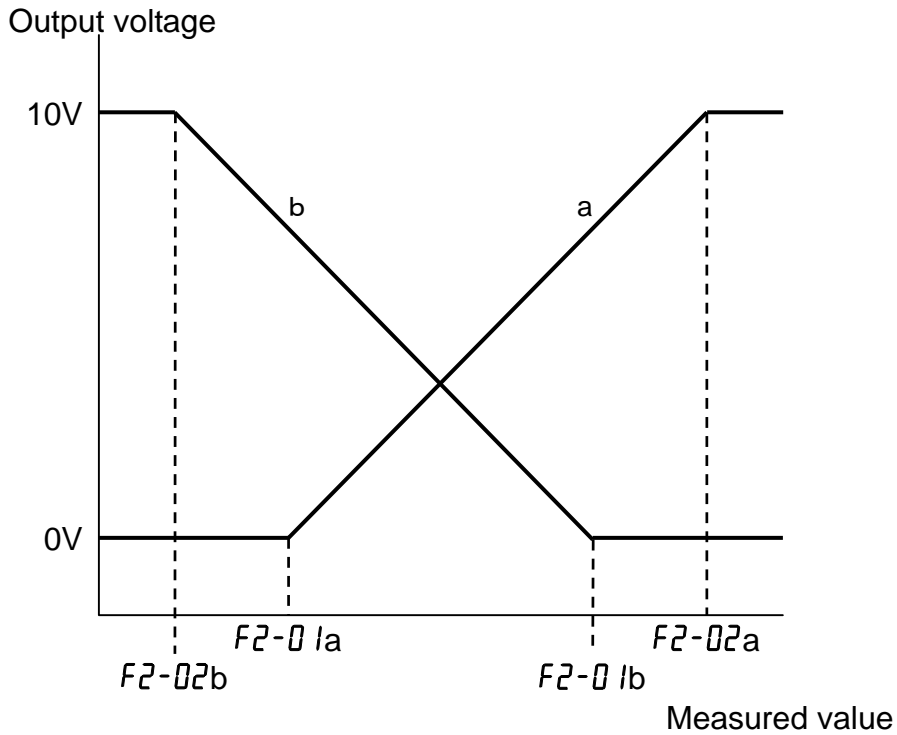

13.2. Analog current DAI (4mA to 20mA)

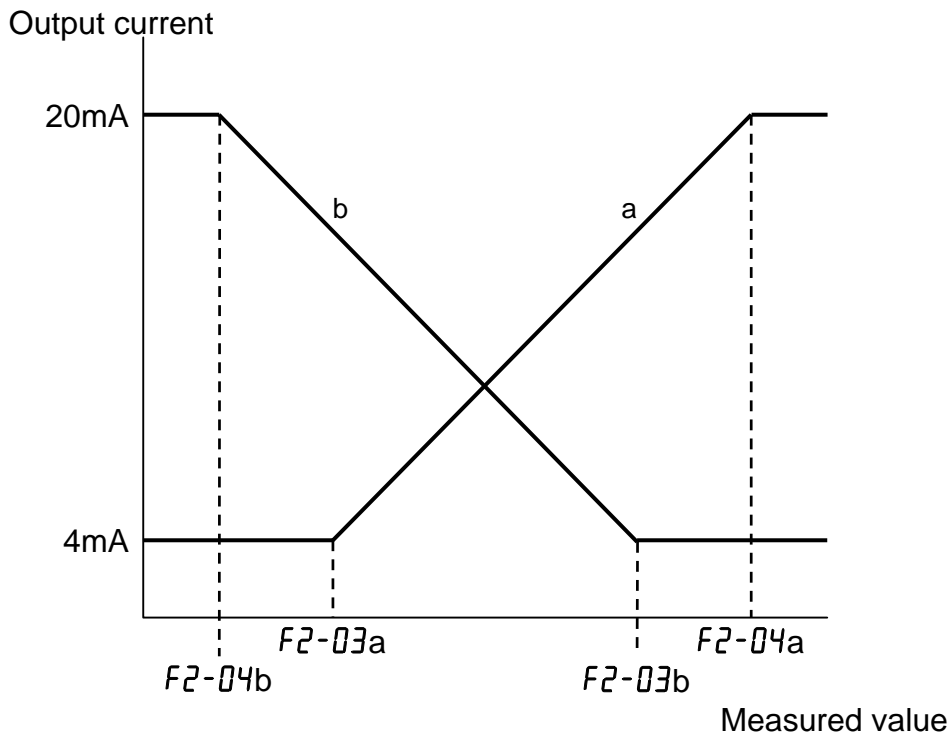

14. SERIAL INPUT AND OUTPUT

14.1. Data output format

Normal measured value	WT, $\pm 0123.45^{C}_{R}{}^{L}_{F}$
No decimal point	WT, $\pm 0012345^{C}_{R}{}^{L}_{F}$
Value exceeding the limit	OL, $\pm 9999.99^{C}_{R}{}^{L}_{F}$
When adding the instrument number	@NNWT, $\pm 0123.45^{C}_{R}{}^{L}_{F}$ (NN is the number specified by F3-07)
When adding the unit	WT, $\pm 0123.45UUUUU^{C}_{R}{}^{L}_{F}$ (U is the character code specified by F4-01 to F4-05)

14.2. Command and response

When receiving an incorrect command, the response is "?". When a command can not be executed, the response is "I".

When adding the instrument number (ID), add "@NN" (NN is the number specified by F3-07) before the command. When the command does not have the "@NN", or the number is incorrect, there will be no response.

The "@NN" is added before the response.

14.2.1. Data request

Output the data that is displayed when the command is received.

Command	R
Command example	$R^{C}_{R}{}^{L}_{F}$
Response example	WT, $\pm 0123.45^{C}_{R}{}^{L}_{F}$

For details about the response, refer to "14.1. Data output format".

14.2.2. Zero command

Perform zero operation.

Command	Z
Command example	$Z^{C}_{R}{}^{L}_{F}$
Response example	$Z^{C}_{R}{}^{L}_{F}$

14.2.3. Hold ON command

Start the hold function.

Command	H
Command example	$H^{C}_{R}{}^{L}_{F}$
Response example	$H^{C}_{R}{}^{L}_{F}$

14.2.4. Hold OFF command

Cancel the hold function.

Command	C
Command example	$C_{R F}^{C L}$
Response example	$C_{R F}^{C L}$

14.2.5. CAL zero command

Update the input voltage ($[F-04]$) at the zero point of the CAL using the data that is input when the command is received.

Command	CZ
Command example	$CZ_{R F}^{C L}$
Response example	$CZ_{R F}^{C L}$

14.2.6. CAL span command

Update the input voltage ($[F-05]$) at the span of the CAL using the data that is input when the command is received.

Command	CS
Command example	$CS_{R F}^{C L}$
Response example	$CS_{R F}^{C L}$

14.2.7. Function reading command

Confirm the function setting.

Query “?” function number: four characters

Command example	?F123 $_{R F}^{C L}$
Response example	F123,±456789 $_{R F}^{C L}$

14.2.8. Function setting command

Change the function setting.

Function number: four characters, the polarity, set value: characters.

Command example	F123,±456789 $_{R F}^{C L}$
Response example	F123,±456789 $_{R F}^{C L}$

15. MAINTENANCE

15.1. Error display

When an error is displayed, perform the appropriate remedy.

Display	Cause	Remedy
<i>Ad E</i>	The data can not be acquired from A/D converter.	Repair is required.
<i>EEPE</i>	Correct data cannot be read from EEPROM.	Perform initialization. If the initialization does not clear the error, repair is required.
<i>CALE</i>	Calibration data error.	Perform calibration.
<i>C E*</i>	Calibration error.	Refer to "7.2. Calibration errors".
<i>dt E</i>	A set value is out of range.	Check set values and correct if necessary.

Display	Cause	Remedy
<i>C E2</i>	Voltage at zero point calibration exceeds in the positive direction.	Confirm the rating and connection of the load cell.
<i>C E3</i>	Voltage at zero point calibration exceeds in the negative direction.	
<i>C E4</i>	The value of the calibration weight exceeds the rated capacity.	Use a proper calibration weight.
<i>C E5</i>	The value of the calibration weight is less than the minimum division.	
<i>C E6</i>	The load cell sensitivity is insufficient.	Confirm the load cell connection. Use a proper calibration weight.
<i>C E7</i>	Voltage at span calibration is less than voltage at the zero point.	Confirm the load cell connection.
<i>C E8</i>	The load cell output voltage is too high when loaded to capacity.	Use a load cell with a greater rated capacity or set a smaller rated capacity value.



15.2. Checking operation

To confirm the operation of the display, key switch and external input and output. Use the check mode.

* The decimal point blinks to indicate that the current value is not a measured value.

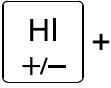
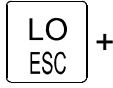
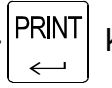
15.2.1. Entering the check mode (Selection mode)

In the measurement mode, press the  +  +  keys to enter the selection mode for the check mode.

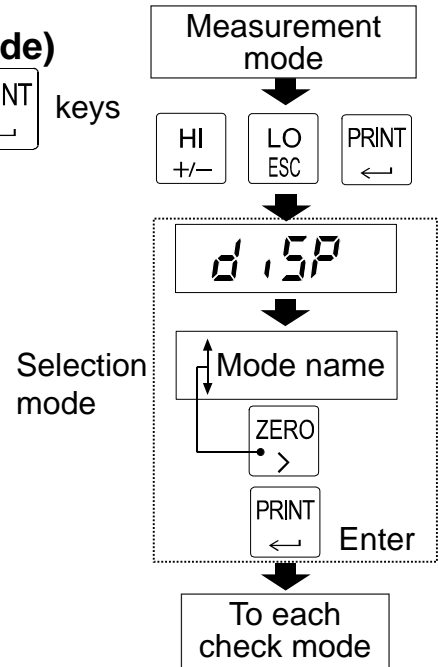

-  Change the item to be checked.
-  Enter the check mode.
-  Return to the measurement mode.



15.2.2. Checking the display

Check the display by turning on each segment and the individual LEDs.

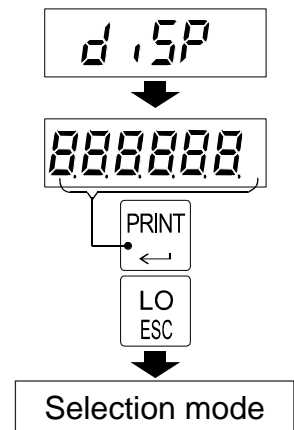

All on / Turn on by digit / Turn on by segment

-  Change the item to be checked. (All on, digit, segment)
-  Proceed to the selection mode. (Refer to “15.2.1”)



15.2.3. Checking the version

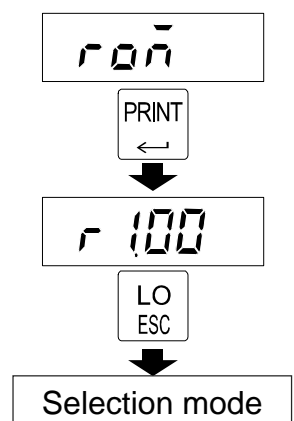

Display the ROM version of the AD-4531B.

-  Display the ROM version.
-  Proceed to the selection mode. (Refer to “15.2.1”)



15.2.4. Checking the A/D conversion (mV/V)

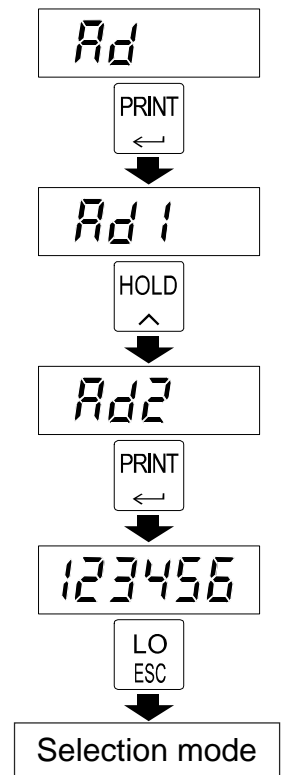

Check the input voltage by displaying in mV/V.

- HOLD**  Select the A/D value to be displayed.
Ad1: mV/V, Ad2: Internal count, Ad3: Display count
- ZERO**  Set the display to zero.
- LO**  Proceed to the selection mode. (Refer to “15.2.1”)



15.2.5. Checking the DAV value

Check the D/A output voltage in 1V steps.

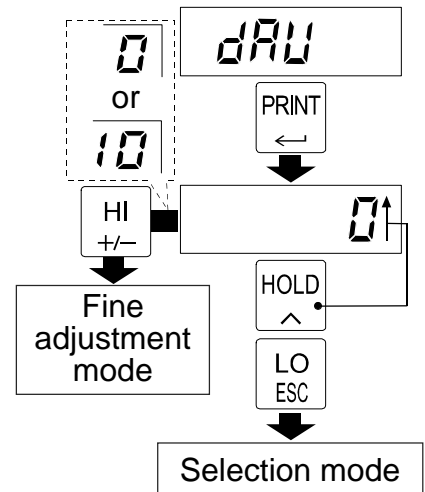

- HOLD**  Increase the output voltage in 1V steps.
(The step after 10V is 0V.)
- HI**  Proceed to the fine adjustment mode.
(When 0V or 10V, hold for 5 seconds.)
- LO**  Proceed to the selection mode.
(Refer to “15.2.1”)



* The output voltage can be finely adjusted using the fine adjustment mode.

15.2.6. Checking the DAI value

Check the D/A current output in 2 mA steps.

- HOLD**  Increase the output current in 2 mA steps.
(The next step after 20 mA is 4 mA.)
- HI**  Proceed to the fine adjustment mode.
(When 4 mA or 20 mA, press for 5 seconds.)
- LO**  Proceed to the selection mode. (Refer to “15.2.1”)

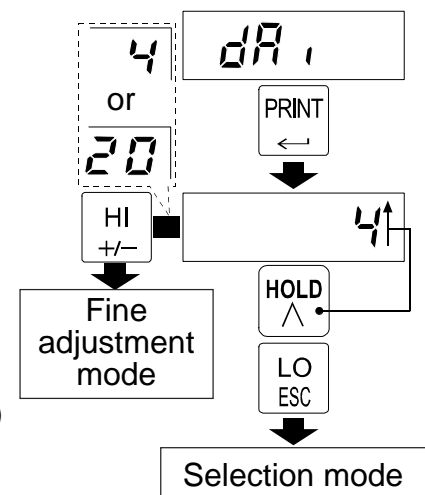

* The output current can be finely adjusted using the fine adjustment mode.

* Fine adjustment mode

In the fine adjustment mode, the DAV can be adjusted in 0.001V steps and DAI, in 0.001mA steps.

When adjusting the 0V or 4mA, the **LO** LED blinks.

When adjusting the 10V or 20mA, the **HI** LED blinks.



Select the adjustment range. (The digit of the range to be adjusted blinks.)



Increase the output within the adjustment range. (If the blinking digit is 9, the digit will be 0 and the next higher-order digit will increase by 1.)



Decrease the output with the adjustment range. (If the blinking digit is 0, the digit will be 9 and the next higher-order digit will decrease by 1.)



Set and save the output.



Return to the previous mode.

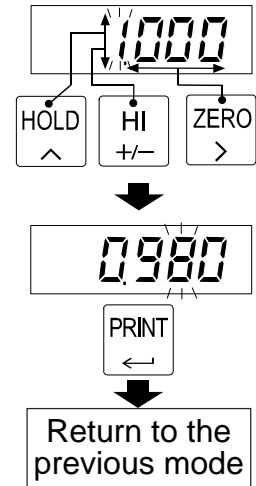

CAUTION

For fine adjustment, use a high precision voltmeter and ammeter. Otherwise, an error in the output value of the AD-4531B may occur.

15.2.7. Checking I/O

Check the control input and comparator output.

Ones digit ON/OFF(1/0) of EXT IN 1 input

Tens digit ON/OFF(1/0) of EXT IN 2 input



Output HI with **HI** turned on.



Output OK with **OK** turned on.



Output LO with **LO** turned on.



Proceed to the selection mode. (Refer to “15.2.1”)

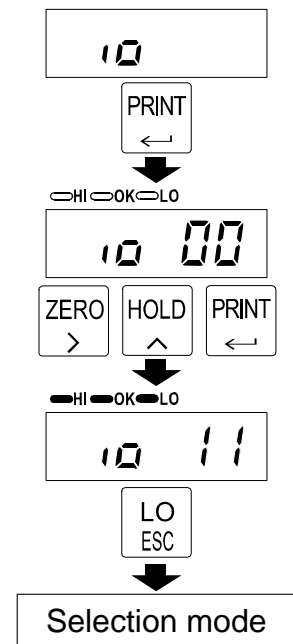

15.2.8. Checking the serial data

Check the serial input and output. (RS-232C/RS-485)

“WT,0123456(unit)” is output in the stream or manual print mode.

When receiving the “R” command, **OK** turns on.

- HI +/-** Switch between the stream mode (**HI** is turned on) or manual print mode (**LO** is turned on).
- ZERO >** While this key is pressed, the baud rate of the setting is displayed.
- HOLD ^** While this key is pressed, the data bit length, parity, stop bit and terminator of the setting are displayed.
- PRINT ←** Output the data.
- LO ESC** Proceed to the selection mode. (Refer to “15.2.1”)

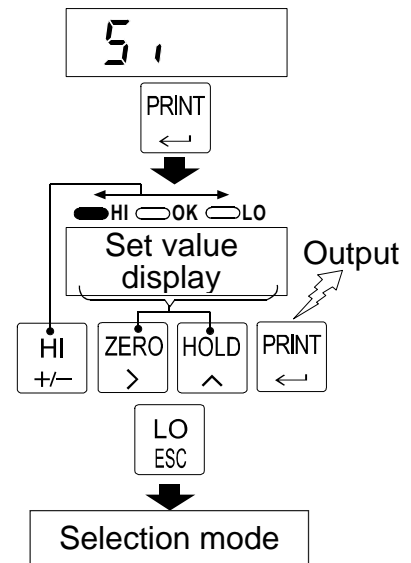

15.2.9. Checking the keys

Check the state of each key.

- PRINT ←** Ones digit (0/1)
- HOLD ^** Tens digit (0/1)
- ZERO >** Hundreds digit (0/1)
- HI +/-** Thousands digit (0/1)
- LO ESC** ten thousands digit (0/1)
(If you want to proceed to the selection mode, press this key twice quickly.)

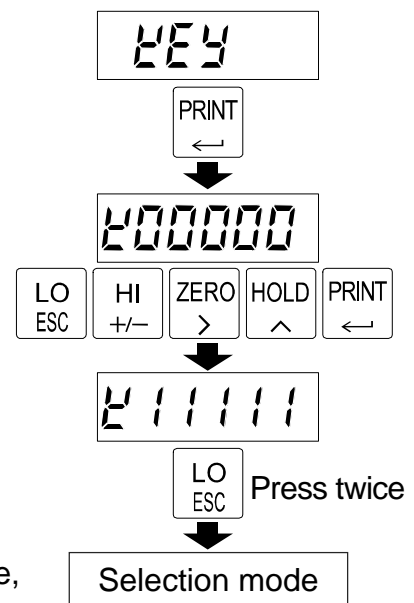

15.2.10. Checking the DZ memory

Display how much space is available in DZ memory as a percentage.

- LO ESC** Proceed to the selection mode. (Refer to “15.2.1”)

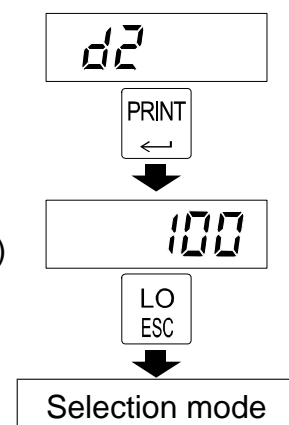

15.2.11. Initialization

Initialize each set value.

Functions initialized:

“in iF” Initialize the F functions.

“in iE” Initialize the F functions and CF functions.

“in iA” Initialize the F functions and CF functions.
Initialize the DAV and DAI adjustment data.



Select what to initialize.



Perform initialization. (Press the key for 5 seconds.)

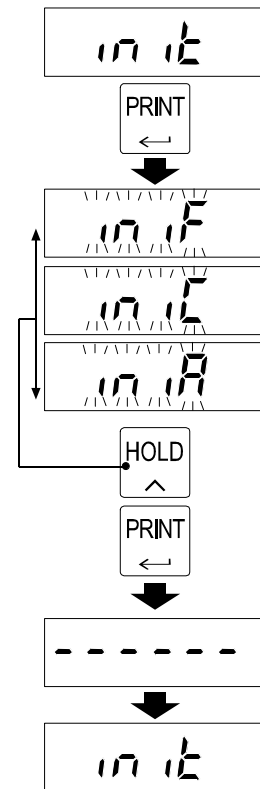

16. SETTING LIST

When performing maintenance, use the following list as a memo.

When making inquiries about the product, inform your local A&D dealer of the user settings.

16.1. Calibration (C function)

Function No. Setting range	Description	Default value	User setting												
<i>CF-01</i> 0 to 5	Decimal point position of the measured value: 0:000000 3:000000 1:000000 4:000000 2:000000 5:000000	0													
<i>CF-02</i> 1 to 50	Minimum division(d) of the measured value. 1:1 5:5 20:20 2:2 10:10 50:50	1													
<i>CF-03</i> 1 to 999999	Rated capacity Measurement is possible up to the value of this setting plus 8 d (8 minimum divisions). Decimal point position depends on <i>CF-01</i> .	70000													
<i>CF-04</i> -7.00000 to 7.00000	Input voltage from the load cell at zero point. □.□□□□mV/V	0.00000													
<i>CF-05</i> 0.00001 to 9.99999	Input voltage from the load cell at span. □.□□□□mV/V	3.20000													
<i>CF-06</i> -999999 to 999999	Displayed value for span (measurement point - zero point). Decimal point position depends on <i>CF-01</i> .	32000													
<i>CF-07</i> 0 to 100	Zero adjustment range. Expressed as a percentage of the rated capacity with the calibration zero point as the center.	100													
<i>CF-08</i> 0.0 to 5.0	Zero tracking time. (Unit: second) When 0.0, zero tracking is not performed.	0.0													
<i>CF-09</i> 0.0 to 9.9	Zero tracking width. (Unit: d) When 0.0, zero tracking is not performed.	0.0													
<i>CF-10</i> 0 to 2	Power on zero: 0: Digital zero function off 1: Perform digital zero 2: Use state when the power is disconnected.	0													
<i>CF-11</i> 1 to 3	Zero operation: 1: On with <table border="1" style="display: inline-table; vertical-align: middle;"><tr><td>ZERO</td></tr><tr><td>></td></tr></table> 2: On with <table border="1" style="display: inline-table; vertical-align: middle;"><tr><td>HI</td></tr><tr><td>+/-</td></tr></table> + <table border="1" style="display: inline-table; vertical-align: middle;"><tr><td>ZERO</td></tr><tr><td>></td></tr></table> 3: On by pressing and holding <table border="1" style="display: inline-table; vertical-align: middle;"><tr><td>ZERO</td></tr><tr><td>></td></tr></table> for more than 1 second	ZERO	>	HI	+/-	ZERO	>	ZERO	>	1	* In all settings: When it is on, off with <table border="1" style="display: inline-table; vertical-align: middle;"><tr><td>HI</td></tr><tr><td>+/-</td></tr></table> + <table border="1" style="display: inline-table; vertical-align: middle;"><tr><td>ZERO</td></tr><tr><td>></td></tr></table>	HI	+/-	ZERO	>
ZERO															
>															
HI															
+/-															
ZERO															
>															
ZERO															
>															
HI															
+/-															
ZERO															
>															
<i>CF-12</i> 1 to 2	Zero of the I/O input: 1: On / Off depends on the I/O input 2: Only digital zero on (no off)	1													

16.2. Basic functions

Function No. Setting range	Description		Default value	User setting
FD-01 00000 to 11111	Disable key Each digit of the setting corresponds to a key switch. Only available in the measurement mode. Key assignment: 0 : Enabled 1 : Disabled 		00000 (Binary)	
FD-02 0 to 9	Digital filter. Cutoff frequency: 0 : Off 5 : 2.8 Hz 1 : 11 Hz 6 : 2 Hz 2 : 8 Hz 7 : 1.4 Hz 3 : 5.6 Hz 8 : 1 Hz 4 : 4 Hz 9 : 0.7 Hz		8	
FD-03 1 to 20	Display update rate: 1 : 1 time/second 10 : 10 times/second 2 : 2 times/second 20 : 20 times/second 5 : 5 times/second		20	
FD-04 0 to 4	Hold mode: 0 : Off 3 : Bottom hold 1 : Sample hold 4 : Bipolar peak hold 2 : Peak hold		1	
FD-05 0.0 to 9.9	Hold averaging time: Set by the unit of 0.1 second. When 0.0 , averaging is not performed.		0.0	
FD-06 0000 to 1111	LATCH function Function corresponds to an external input latch. Setting and latch Assignment: 0 : Off 0 0 0 0 1 : On 		0000 (Binary)	
FD-07 0 to 6	External input 1	0 : Off 4 : Start hold 1 : DZ key 5 : Stop hold	1	
FD-08 0 to 6	External input 2	2 : Hold 6 : Latch 3 : Print	2	
FD-09 0 to 9	External output 1	0 : Off 5 : OK 1 : DZ key 6 : Lo 2 : Holding 7 : Measuring (ON)	1	
FD-10 0 to 9	External output 2	3 : Hold busy 8 : Measuring (1 Hz) 4 : Hi 9 : Measuring (50 Hz)	2	

16.3. Comparator

Function No. Setting range	Description	Default value	User setting
<i>F 1-01</i> -999999 to 999999	Upper limit value of comparator. Decimal point position depends on <i>CF-01</i> .	<i>0</i>	
<i>F 1-02</i> -999999 to 999999	Lower limit value of comparator. Decimal point position depends on <i>CF-01</i>	<i>0</i>	
<i>F 1-03</i> 0 to 2	Comparator mode: <i>0</i> : No comparison <i>1</i> : Comparison, excluding the zero band <i>2</i> : Comparison, including the zero band	<i>2</i>	
<i>F 1-04</i> -999999 to 999999	Set the zero band for the comparator mode.	<i>0</i>	
<i>F 1-05</i> 1 to 3	Hysteresis direction: <i>1</i> : Upward 2-level judgment <i>2</i> : Upper / lower limit judgment <i>3</i> : Downward 2-level judgment	<i>2</i>	
<i>F 1-06</i> 0.0 to 5.0	Hysteresis time. (Unit: 0.1 second) When <i>00</i> , the hysteresis mode is not used.	<i>00</i>	
<i>F 1-07</i> 00 to 99	Hysteresis width. (Unit: d) When <i>00</i> , the hysteresis mode is not used.	<i>99</i>	

16.4. Analog

Function No. Setting range	Description	Default value	User setting
<i>F2-01</i> -999999 to 999999	Measured value at DAV 0V output. Decimal point position depends on <i>CF-01</i> .	<i>0</i>	
<i>F2-02</i> -999999 to 999999	Measured value at DAV 10V output. Decimal point position depends on <i>CF-01</i> .	<i>10000</i>	
<i>F2-03</i> -999999 to 999999	Measured value at DAI 4 mA output. Decimal point position depends on <i>CF-01</i> .	<i>0</i>	
<i>F2-04</i> -999999 to 999999	Measured value at DAI 20 mA output. Decimal point position depends on <i>CF-01</i> .	<i>10000</i>	

16.5. Serial communication

Function No. Setting range	Description	Default value	User setting
<i>F3-01</i> 2400 to 38400	Baud rate: <i>2400</i> : 2400 bps <i>19200</i> : 19200 bps <i>4800</i> : 4800 bps <i>38400</i> : 38400 bps <i>9600</i> : 9600 bps	<i>2400</i>	
<i>F3-02</i> 7 to 8	Data bit length: <i>7</i> : 7 bits <i>8</i> : 8 bits	<i>7</i>	
<i>F3-03</i> 0 to 2	Parity: <i>0</i> : None <i>1</i> : Odd <i>2</i> : Even	<i>2</i>	
<i>F3-04</i> 1 to 2	Stop bit: <i>1</i> : 1 bit <i>2</i> : 2 bits	<i>1</i>	
<i>F3-05</i> 1 to 2	Terminator: <i>1</i> : CRLF ASCII code: CR: 0D, LF: 0A <i>2</i> : CR	<i>1</i>	
<i>F3-06</i> 1 to 6	Output mode: <i>1</i> : Stream <i>2</i> : Manual print mode <i>3</i> : Auto print mode (Outputs data once when the measured value exceeds the zero range and is stabilized for the first time.) <i>4</i> : Auto print mode (Outputs data each time the measured value exceeds the zero range and is stabilized.) <i>5</i> : Command mode <i>6</i> : Jet stream mode (Outputs data at each sampling, depending on the baud rate.)	<i>2</i>	
<i>F3-07</i> 00 to 99	Instrument No. When <i>00</i> , the ID is not added.	<i>00</i>	

16.6. Unit

Function No. Setting range	Description	Default value	User setting
<i>F4-00</i> 0 to 4	Unit <i>0</i> : Specify the unit character (<i>F4-01</i> to <i>F4-05</i>) <i>1</i> : kg <i>3</i> : t <i>2</i> : g <i>4</i> : lb	<i>1</i>	
<i>F401</i> <i>F402</i> <i>F403</i> <i>F404</i> <i>F405</i> 00 to 7F	Unit character (5 character) <i>00</i> : no unit	<i>00</i> (Hexadecimal)	

17. EXTERNAL DIMENSIONS

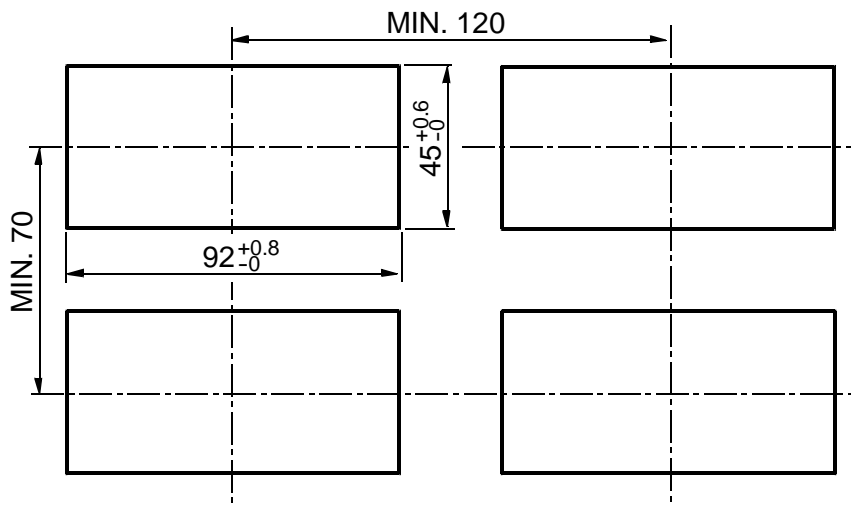
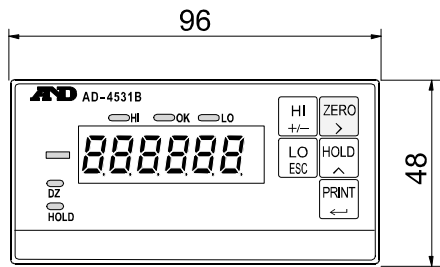
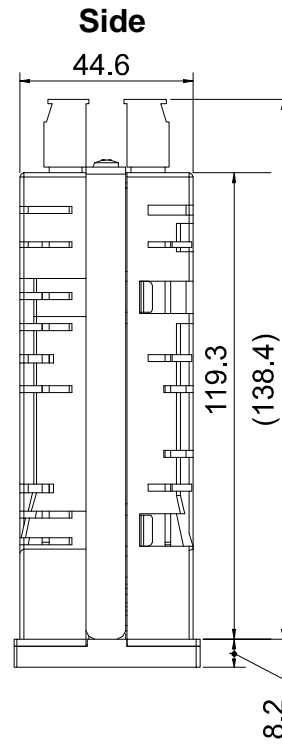
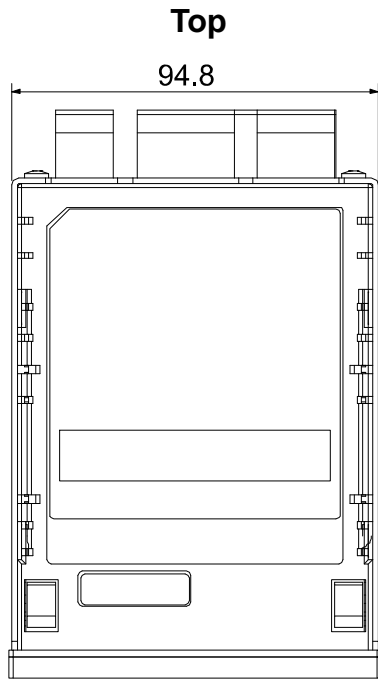

Panel cutout dimensions / Spacing

*Maintain the intervals above when installing

UNIT: mm

MEMO



A&D Company, Limited

3-23-14 Higashi-Ikebukuro, Toshima-ku, Tokyo 170-0013, JAPAN
Telephone: [81] (3) 5391-6132 Fax: [81] (3) 5391-6148

A&D ENGINEERING, INC.

1756 Automation Parkway, San Jose, California 95131, U.S.A.
Telephone: [1] (408) 263-5333 Fax: [1] (408)263-0119

A&D INSTRUMENTS LIMITED

Unit 24/26 Blacklands Way, Abingdon Business Park, Abingdon, Oxfordshire OX14 1DY United Kingdo
Telephone: [44] (1235) 550420 Fax: [44] (1235) 550485

A&D AUSTRALASIA PTY LTD

32 Dew Street, Thebarton, South Australia 5031, AUSTRALIA
Telephone: [61] (8) 8301-8100 Fax: [61] (8) 8352-7409

A&D KOREA Limited

한국에이.엔.디(주)
대한민국 서울시 영등포구 여의도동 36-2 맨하탄 빌딩 8층 우편 번호 150-749
(Manhattan Building 8th Floor, 36-2 Yoido-dong, Youngdeungpo-gu, Seoul, 150-749 Korea)
전화: [82] (2) 780-4101 팩스: [82] (2) 782-4280

OOO A&D RUS

ООО "ЭЙ энд ДИ РУС"
121357, Российская Федерация, г.Москва, ул. Верейская, дом 17
(Business-Center "Vereyskaya Plaza-2" 121357, Russian Federation, Moscow, Vereyskaya Street 17)
тел.: [7] (495) 937-33-44 факс: [7] (495) 937-55-66

A&D INSTRUMENTS INDIA PRIVATE LIMITED

ऐ&डी इन्स्ट्रुमेन्ट्स इण्डिया प्रा० लिमिटेड
509, उद्योग विहार , फेस -5, गुडगांव - 122016, हरियाणा , भारत
(509, Udyog Vihar, Phase-V, Gurgaon - 122 016, Haryana, India)
फोन : 91-124-4715555 फैक्स : 91-124-4715599